

MGQ Series High Stability Quartz Crystal Units

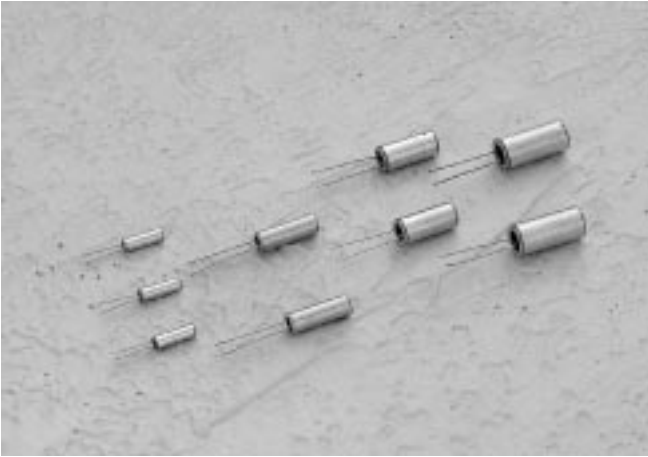

FEATURES

- Suitable for low voltage drive.
- Excellent frequency-temperature curve.
- Excellent shock resistance and aging characteristics.

APPLICATIONS

- Radio Communication Equipment, Pagers, Cellular Telephones, Portable Applications, Clock Source for Micro-Computers, Facsimile, Computer controllers.

STANDARD FREQUENCIES(MHZ)

MGQ-460	MGQ-388	MGQ-308	MGQ-206
1.000	1.200	1.792	3.000
1.048576	1.2288	1.800	3.200
	1.280	1.8432	
	1.536	1.920	
	1.580	2.000	
	1.600	2.080053	
	1.6384	2.097152	
		2.100	
		2.112	
		2.400	
		2.40299	
		2.4576	
		2.5103	
		2.560	
		2.688	

DIMENSIONS

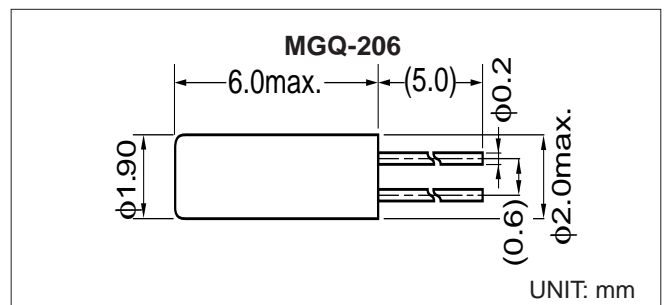
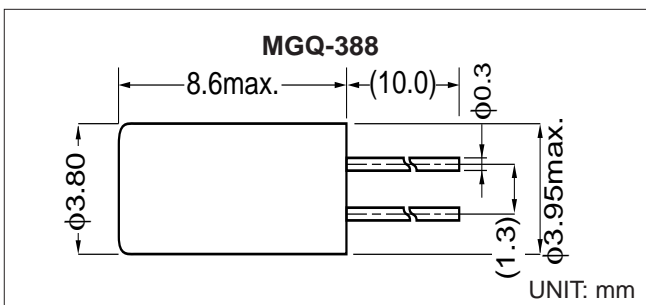
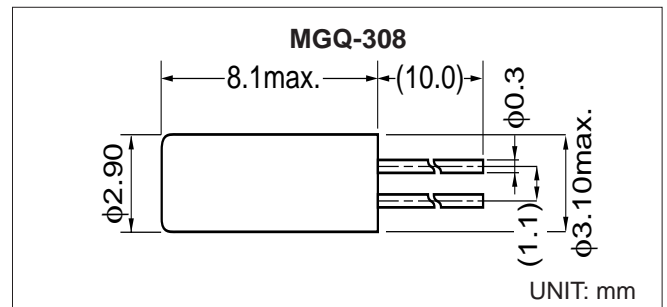
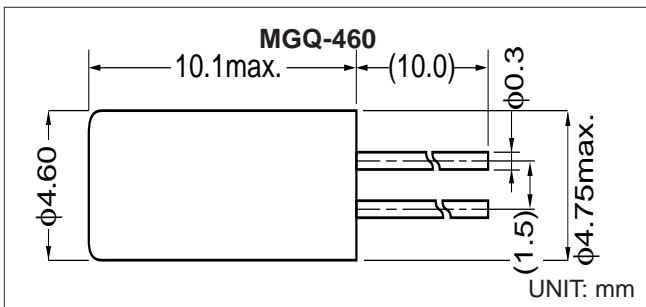

FREQUENCY-TEMPERATURE CURVES

(Comparison with other type crystals)

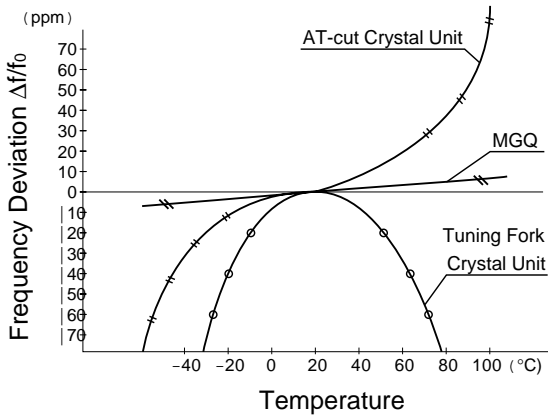

DRIVE LEVEL MEASUREMENT (Refer to Page 3 Drive Level)

I_x is measured by current probe.

$$I_x = \frac{V_p}{2\sqrt{2}}$$

The Drive Level (DL) equals $I_x^2 \cdot R_e$

The Standard specification of the Drive Level is shown following table.

For more information regarding the oscillator circuit design, please contact SII.

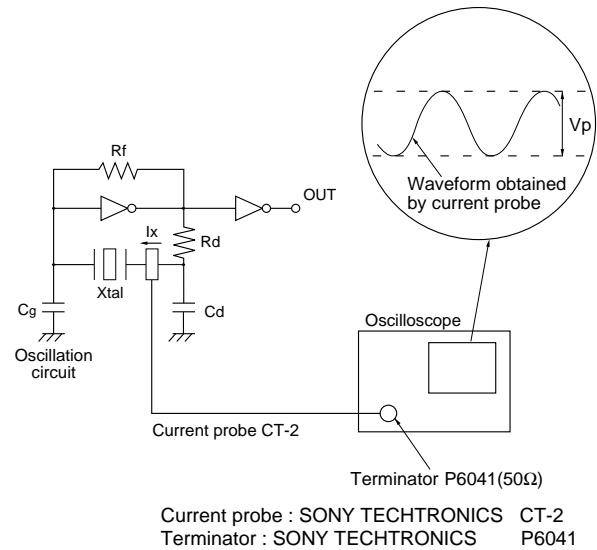

STANDARD SPECIFICATIONS

Conditions without notice (Temperature: +25°C ±2°C)

Item	Symbol	MGQ-460	MGQ-338	MGQ-308	MGQ-206	Conditions
Nominal Frequency	f_0	1MHz to 1.19MHz	1.2MHz to 1.69MHz	1.7MHz to 2.67MHz	2.68MHz to 3.2MHz	
Frequency Tolerance	$\Delta f/f_0$	±10ppm, ±20ppm, ±40ppm, ±100ppm				
Frequency Temperature Stability	$\Delta f/f_0$	±2.5ppm, ±5ppm, ±10ppm, ±25ppm, ±50ppm, ±100ppm				-30°C to 70°C
Load Capacitance	C_L	10 pF				
Equivalent Series Resistance	R_1	100Ω max.	150Ω max.	200Ω max.	300Ω max.	
Drive Level	DL	20 μW max.	10 μW max.	5 μW max.	3 μW max.	
Shunt Capacitance	C_0	5 pF typ.	3.7 pF typ.	2.5 pF typ.	1.5 pF typ.	
Aging	$\Delta f/f_0$	±3ppm max.				+25°C±3°C, First Year
Operating Temperature Range	Tope	-30°C to +70°C				
Storage Temperature Range	Tsto	-45°C to +80°C				
Solderability	Tsol	280°C max., 5sec.max (Package 150°C max.)				Leads Only

Note: For more information regarding the oscillator circuit design, please contact SII.
Available temperature stability depends upon frequency.

Quartz Crystal Unit Handling Precautions

1. Mounting Precautions

1.1 Lead Type Crystal Units

1.1.1 Structure

Tubular crystal units (VT, VTC, MGQ, and MAT) are hermetically sealed using glass (see Figures 1 and 2).

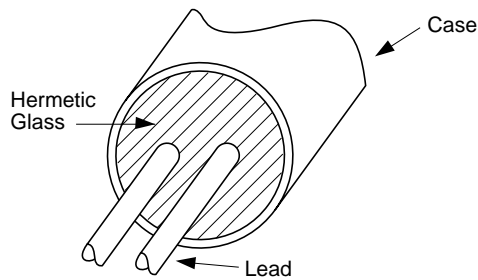

Figure 1

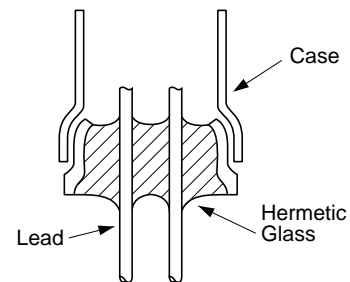

Figure 2

1.1.2 Unbending the lead

- (1) **DO NOT** pull the lead excessively if unbending a lead or removing a crystal unit. The excessive force may crack the glass and reduce the degree of vacuum. This may eventually result in deterioration of the characteristics and may also break the crystal chip (see Figure 3).
- (2) Unbend the lead by pressing on the bent part from both the upper and lower sides with fixing the bottom of lead tightly. (see Figure 4).

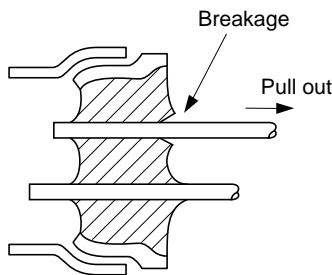

Figure 3

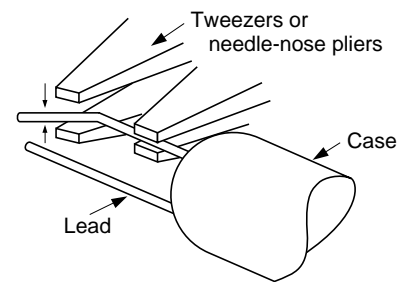

Figure 4

1.1.3 Bending the lead

- (1) Bend the lead so that the lead remains straight for more than 0.5mm from the case when soldering after bending a lead. If not, the glass may be cracked (see Figures 5 and 6).
- (2) Always leave a length greater than the case diameter when bending a lead after soldering (see Figure 7).

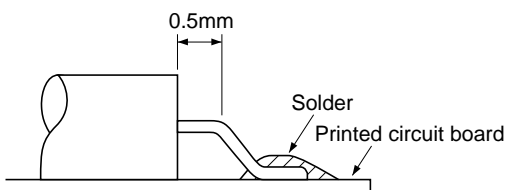

Figure 5

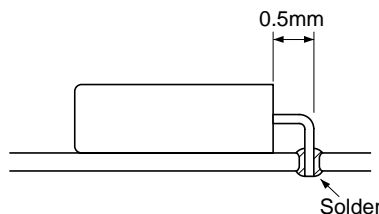

Figure 6

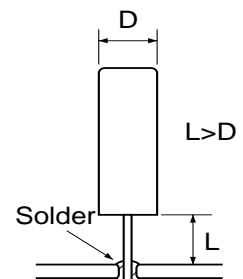

Figure 7

Soldering directly to the case will reduce the degree of vacuum and may result in deterioration of the characteristics and may break the crystal chip.

Make the length from the case to the printed circuit board (L) longer than the case diameter (D) so that the lead wire will not be pulled if the crystal unit falls over.

1.1.4 Soldering

Heat the lead wire at a temperature of less than 280°C for 5 seconds or less, when mounting or removing a crystal unit. A long period time of heating may result in deterioration of the characteristics and may break the crystal unit.

1.2. SMD Type Quartz Crystal Units

1.2.1 Soldering

- (1) For mounting, it is recommended to solder at less than 230°C for 20 seconds or less. An example of the infrared ray reflow temperature profile is shown as follows (see Figure 8).

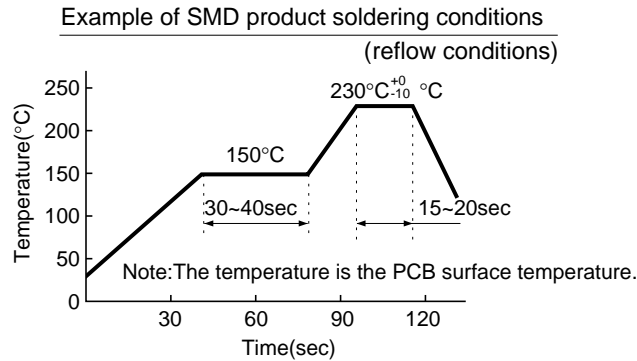

2. Cleaning

- (1) Since low or intermediate frequency crystal units (VT, VTC, and MGQ) or oscillators use a small, thin crystal chip and the frequency approximates the frequency of an ultrasonic cleaner, the crystal chip may break easily. Therefore, DO NOT perform ultrasonic cleaning.
- (2) Other crystal units may also break depending upon the ultrasonic cleaning condition. Please check the ultrasonic cleaning condition.

3. Mechanical Shock

- (1) The quartz crystal units are designed to withstand a drop from a height of 75 cm onto a hard wooden board at least three times. However, the crystal chip may break if dropped, depending upon the how they are dropped. Ensure that the crystal unit functions normally, if the crystal units have been dropped or subjected to an excessive mechanical shock.
- (2) Unlike chip parts for resistors, and capacitors, the crystal unit has a crystal chip which is hermetically sealed inside. Before using the crystal units, check the influence of shock caused during automatic mounting.

Packing

The following is the standard packing. In the case of a small quantity of products (less than 1 lot), this packing may differ.

1. Lead type products

One hundred to five hundred units are packed in a vinyl bag. Twenty to forty bags are packed in a box and shipped.

Product name	Quantity per lot	Quantity per bag	Quantity per box
VT Series	10,000 pcs.	500 pcs.	20 bags
VTC Series	10,000 pcs.	500 pcs.	20 bags
MAT Series	4,000 pcs.	100 pcs.	40 bags

The following products are individually packed in a partitioned styrofoam package (150 pcs.). Several packages are bound and packed in a delivery container to ship.

Product name	Quantity per lot	Quantity per package	Quantity per container
MGQ Series	600 pcs.	150 pcs.	4 packages
MGXO Series	100 pcs.	Stuck into a conductive mat and packed in a box.	

2. SMD products

After being taped, the products are rolled onto a reel. The reels are packed in a box.

Product name	SP-T1	SP-T2	SP-T3	HTF-VT/VTC
Quantity per reel	2,000 pcs.	3,000 pcs.	3,000 pcs.	3,000 pcs.

Note: Specifications may differ when shipped in small quantities.

Tape and reel configuration

Emboss tapping configuration

SP-T1/T2/T3

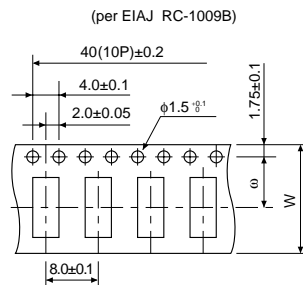

HTF-VT-VTC

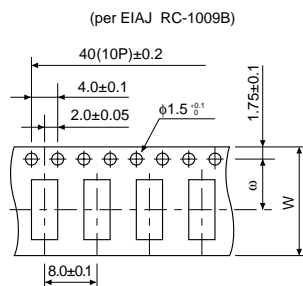

	SP-T1/T2/T3,HTF-VT/VTC
ω	7.5
W	16.0

Reel configuration

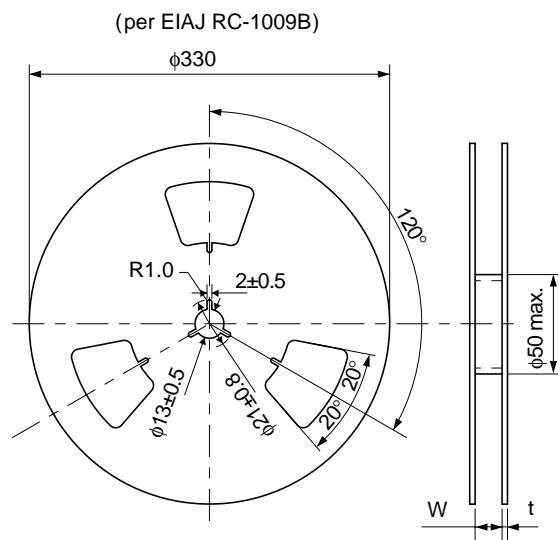

	SP-T1/T2/T3,HTF-VT/VTC
W	16.4
t	2.0

UNIT: mm