

RoHS Compliant 1X9 SC Duplex Receptacle Transceiver Module for Gigabit Ethernet



Features

- Industry Standard 1 x 9 Footprint and duplex SC Connector interface
- Compliant with Specifications for IEEE 802.3z Gigabit Ethernet
- OPT-1250Bxxx compliant with the 1.0625GBd Fibre Channel 100-SM-LC-L FC-PI Rev.13
- OPT-1250Axxx compliant with the 1.0625GBd Fibre Channel FC-PI 100-M5-SN-I Rev.13
- Single +3.3V or 5V Power Supply
- PECL or TTL Receiver Signal Detect Indicator
- Wave Solderable and Aqueous Washable
- Laser Class 1 Product which comply with the requirements of IEC 60825-1 and IEC 60825-2

Description

The OPT-1250xxxx series from DELTA is a 1X9 transceiver module designed expressly for high-speed communication applications that require rates of up to 1.25Gbit/sec. It is compliant with the Gigabit Ethernet standards as well as 1x Fiber channel standards.

The OPT-1250xxxx transceivers are provided with the SC receptacle that is compatible with the industry standard SC connector.

The post-amplifier of the OPT-1250xxxx also includes a Signal Detect circuit that provides a PECL or TTL logic-Low output when an unusable optical signal level is detected. (see order information)

The OPT-1250xxxx transceiver is a Class 1 eye safety product. The optical power levels, under normal operation, are at eye safe level.

Applications

- Gigabit Ethernet/Fast Ethernet
- Switched backplane applications

Performance

OPT-1250AxFxx:

- 850nm VCSEL, up to 500m in 50/125 μ m MMF
- 850nm VCSEL, up to 220m in 62.5/125 μ m MMF

OPT-1250B2I1x:

- 1310nm FP laser, Data Link up to 5km in 9/125um SMF

OPT-1250BxQxx:

- 1310nm FP laser, Data Link up to 10km in 9/125um SMF
- 1310nm FP laser, up to 550m in 50/125 μ m MMF
- 1310nm FP laser, up to 550m in 62.5/125 μ m MMF

Absolute Maximum Ratings

| Parameter | Symbol | Min. | Typ. | Max. | Unit | Note |
|----------------------------|-------------------|------|------|------|------|------|
| Storage Temperature | T _S | -40 | | 85 | °C | |
| Lead Soldering Temperature | T _{SOLD} | | | 260 | °C | |
| Lead Soldering Time | t _{SOLD} | | | 10 | sec. | |
| Supply Voltage | V _{CC} | 0 | | 6 | V | |

Recommended Operating Conditions

| Parameter | Symbol | Min. | Typ. | Max. | Unit | Note |
|--|-----------------|-------|------|-------|------|------|
| Ambient Operating Temperature | T _A | 0 | | 70 | °C | 1 |
| Supply Voltage | V _{CC} | 4.75 | | 5.25 | V | |
| OPT-1250x1xx OPT-1250x2xx, OPT-1250x4xx | | 3.135 | | 3.465 | | |

Note: See ordering information for detail

Electrical Characteristics

(At recommended ambient operating temperature, T_A and supply voltage, V_{CC})

| Parameter | Symbol | Min. | Typ. | Max. | Unit | Note |
|--|-----------------------------------|--------|------|-----------------|------|------|
| Total Supply Current | I _{CC} | | | 300 | mA | |
| Transmitter | | | | | | |
| Transmitter Data Input Voltage-Low | V _{IL} -V _{CC} | -1.810 | | -1.475 | V | 1 |
| Transmitter Data Input Voltage-High | V _{IH} -V _{CC} | -1.165 | | -0.880 | V | 1 |
| Transmitter Differential Input Voltage | V _{DT} | 0.3 | | 1.6 | V | 2 |
| Receiver | | | | | | |
| Data Output Voltage-Low | V _{OL} -V _{CC} | -1.95 | | -1.62 | V | 1 |
| Data Output Voltage-High | V _{OH} -V _{CC} | -1.045 | | -0.74 | V | 1 |
| Receiver Differential Output Voltage | V _{DR} | 0.5 | 0.7 | 1.2 | V | 2 |
| Output Data Rise/Fall Time | t _r /t _f | | | 0.4 | ns | 3 |
| PECL SD Output | | | | | | |
| LOW level output voltage | V _{SDH} -V _{CC} | -1.84 | | -1.60 | V | 4 |
| HIGH level output voltage | V _{SDL} -V _{CC} | -1.1 | | -0.9 | | |
| TTL SD Output | | | | | | |
| LOW level output voltage | V _{SDH} | 2 | | V _{CC} | V | 5 |
| HIGH level output voltage | V _{SDL} | 0 | | 0.8 | | |

Notes:

- For OPT-1250A1F1x, OPT-1250A4F1x, OPT-1250B2I1x, OPT-1250B2Q1x and OPT-1250B1Q1x.
- For OPT-1250A2F2x and OPT-1250B4Q2x.
- These are 20%~80% values
- For OPT-1250A1F1x, OPT-1250A2F2x, OPT-1250B2I1x, OPT-1250B1Q1x and OPT-1250B2Q1x
- For OPT-1250A4F1x and OPT-1250B4Q2x

Single Mode Transceiver (OPT-1250B211x, OPT-1250B1Q1x, OPT-1250B2Q1x, OPT-1250B4Q2x)

(At recommended ambient operating temperature, T_A and supply voltage, V_{CC} ; Data Rate=1.25Gb/sec, PRBS= 2^7-1 NRZ, 9/125um SMF)

| Parameter | Symbol | Min. | Typ. | Max. | Unit | Note |
|---|---|-------------|------|----------|-------|------|
| Transmitter | | | | | | |
| Output Optical Power (Avg.) OPT-1250Bx1x OPT-1250BxQx | P_O | -12 -9.5 | | -3 -3 | dBm | |
| Optical Extinction Ratio | ER | 9 | | | dB | |
| Center Wavelength | c | 1270 | 1310 | 1355 | nm | |
| Spectral Width (RMS) | | | | 2.8 | nm | |
| Optical Rise/Fall time | t_r/t_f | | | 0.26 | ns | 1 |
| Relative Intensity Noise | RIN | | | -120 | dB/Hz | |
| Output Eye | Complies with the IEEE 802.3z/D2 specification, and is class 1 laser eye safety | | | | | |
| Receiver | | | | | | |
| Sensitivity (Avg.) | P_{IN} | | | -19 | dBm | 2 |
| Input Optical Wavelength | | | 1310 | | nm | |
| Signal Detect-Asserted (Avg.) | P_A | | | -19 | dBm | |
| Signal Detect-De-asserted (Avg.) | P_D | -35 | | | dBm | |
| Signal Detect-Hysteresis | P_A-P_D | 0.5 | | | dB | |
| Receiver saturation power | P_{SAT} | -3 | | | dBm | |

Notes:

- These are 20%~80% values
- The sensitivity is provided at a BER of 1×10^{-10} or better with an input signal consisting of 1250Mb/s, 2^7-1 PRBS.

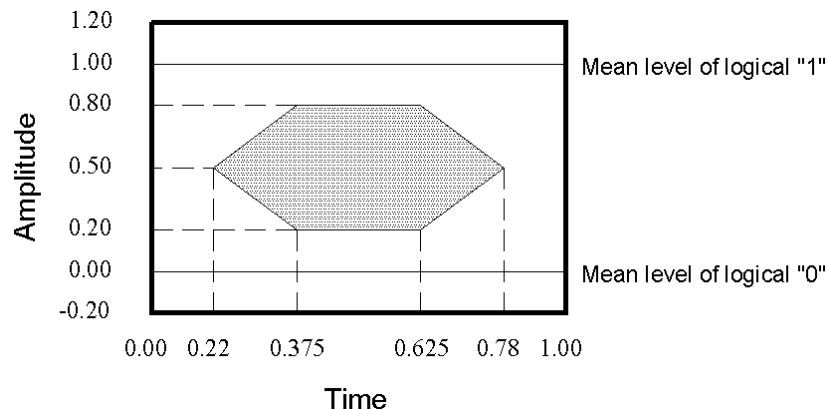
Mask of the eye diagram for the optical transmit signal

Multi-Mode Series Transceiver (OPT-1250A1F1x, OPT-1250A2F2x, OPT-1250A4F1x)

(At recommended ambient operating temperature, T_A and supply voltage, V_{CC} ; Data Rate=1.25Gb/sec, PRBS= 2^7-1 NRZ, 62.5/125um MMF)

| Parameter | Symbol | Min. | Typ. | Max. | Unit | Note |
|----------------------------------|---|------|------|------|-------|------|
| Transmitter | | | | | | |
| Output Optical Power (Avg.) | P_O | -9.5 | | -4 | dBm | |
| Optical Extinction Ratio | ER | 9 | | | dB | |
| Center Wavelength | λ_c | 830 | 850 | 860 | nm | |
| Spectral Width (RMS) | | | | 0.85 | nm | |
| Optical Rise/Fall time | t_r/t_f | | | 0.26 | ns | 1 |
| Relative Intensity Noise | RIN | | | -117 | dB/Hz | |
| Output Eye | Complies with the IEEE 802.3z/D2 specification, and is class 1 laser eye safety | | | | | |
| Receiver | | | | | | |
| Sensitivity (Avg.) | P_{IN} | | | -17 | dBm | 2 |
| Input Optical Wavelength | | | 850 | | nm | |
| Signal Detect-Asserted (Avg.) | P_A | | | -17 | dBm | |
| Signal Detect-De-asserted (Avg.) | P_D | -30 | | | dBm | |
| Signal Detect-Hysteresis | P_A-P_D | 0.5 | | | dB | |
| Receiver saturation power | P_{SAT} | -4 | | | dBm | |

Notes:

- 8. These are 20%~80% values
- 9. The sensitivity is provided at a BER of 1×10^{-10} or better with an input signal consisting of 1250Mb/s, 2^7-1 PRBS.

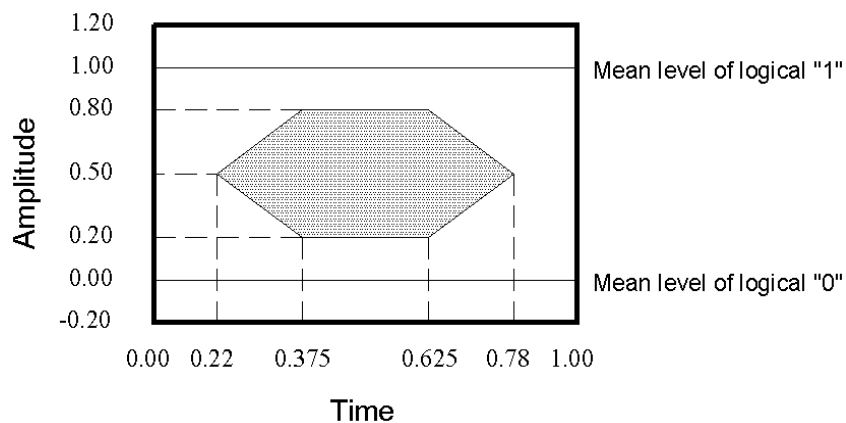

Mask of the eye diagram for the optical transmit signal

Pin Out Table

| PIN | Symbol | Functional description |
|-----|--------|--|
| 1 | GND | Receiver Signal Ground |
| 2 | RD (+) | Receiver Data Out (LVPECL) |
| 3 | RD (-) | Receiver Data Out Bar (LVPECL) |
| 4 | SD | Receiver Signal Detect (LVPECL or TTL) |
| 5 | VccR | Receiver Power Supply, |
| 6 | VccT | Transmitter Power Supply |
| 7 | TD (-) | Transmitter Data In Bar (LVPECL) |
| 8 | TD (+) | Transmitter Data In (LVPECL) |
| 9 | GND | Transmitter Signal Ground |

Pin Descriptions:

Pin 1 Receiver Signal Ground, GND

Directly connect these pins to the ground plane.

Pin 2 Receiver Data Out (LVPECL), RD (+)

Receiver Data output (LVPECL), RD (+).

Pin 3 Receiver Data Out Bar (LVPECL), RD (-)

Receiver Data output (LVPECL), RD (-).

Pin 4 Receiver Signal Detect (LVPECL/TTL), SD

PECL/TTL logic family. Normal Operation: Logic "1" Output

Fault Condition: Logic "0" Output.

Pin 5 Receiver Power Supply, VccR

Provide +3.3/5V dc power supply.

Pin 6 Transmitter Power Supply, VccT

Provide +3.3/5V dc power supply.

Pin 7 Transmitter Data In Bar (LVPECL), TD (-)

Transmitter Data Input (LVPECL), TD (-)

Pin 8 Transmitter Data In (LVPECL), TD (+)

Transmitter Data Input (LVPECL), TD (+)

Pin 9 Transmitter Signal Ground, GND

Directly connect these pins to the ground plane.

Recommend Circuit Schematic for Internal DC Coupled Transceivers

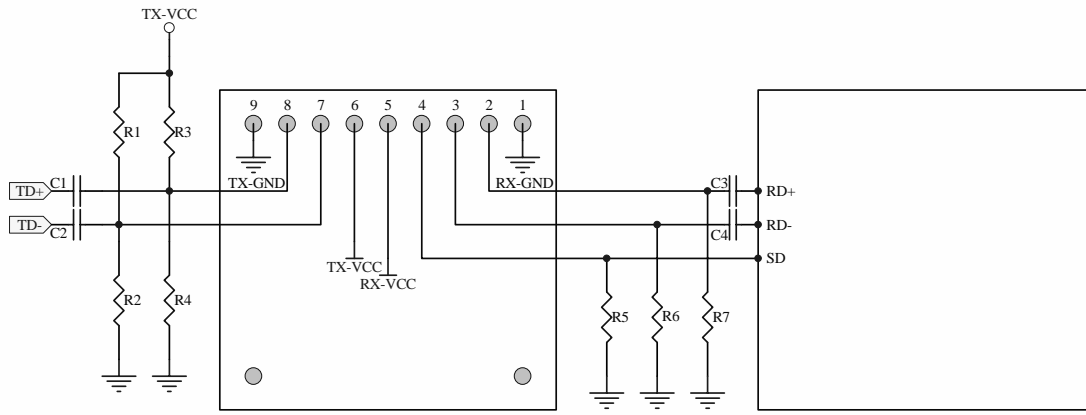

- Transceiver Top View**
- R1=R3=82 Ohm (3.3V), 68 Ohm (5V)
 - R2=R4=130 Ohm (3.3V), 191 Ohm (5V)
 - R5=270 Ohm (3.3V, PECL), 510 Ohm (5V, PECL)
 - NC (TTL)
 - R6=R7=274 Ohm (5V)
 - C1=C2=C3=C4=C6=C8=100 nF
 - C5=100 uF
 - C7=C9=10 uF
 - L1=L2=1 uH or ferrite inductor

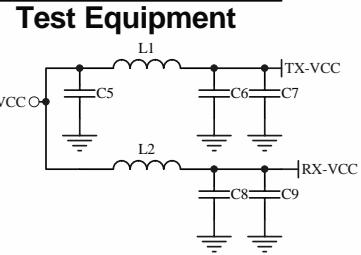

Recommend Circuit Schematic for Internal AC Coupled Transceivers

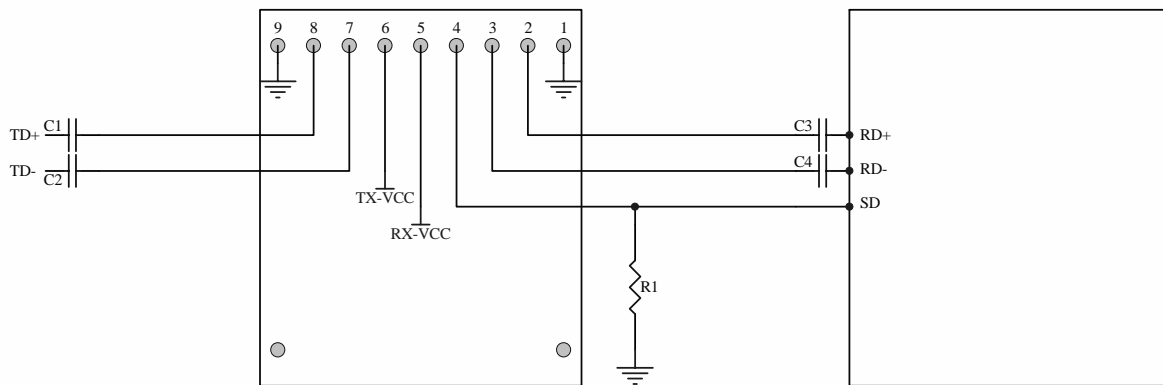

- Transceiver Top View**
- R1=270 Ohm(3.3V, PECL), 510 Ohm (5V, PECL)
 - NC(TTL)
 - C1=C2=C3=C4=C6=C8=100 nF
 - C5=100 uF
 - C7=C9=10 uF
 - L1=L2=1 uH or ferrite inductor

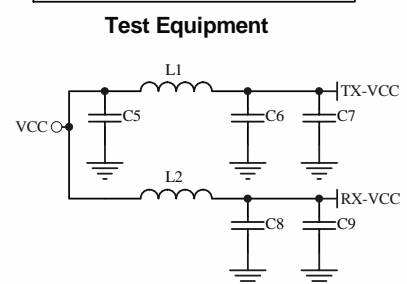

Package Outline Drawing (without shielding)

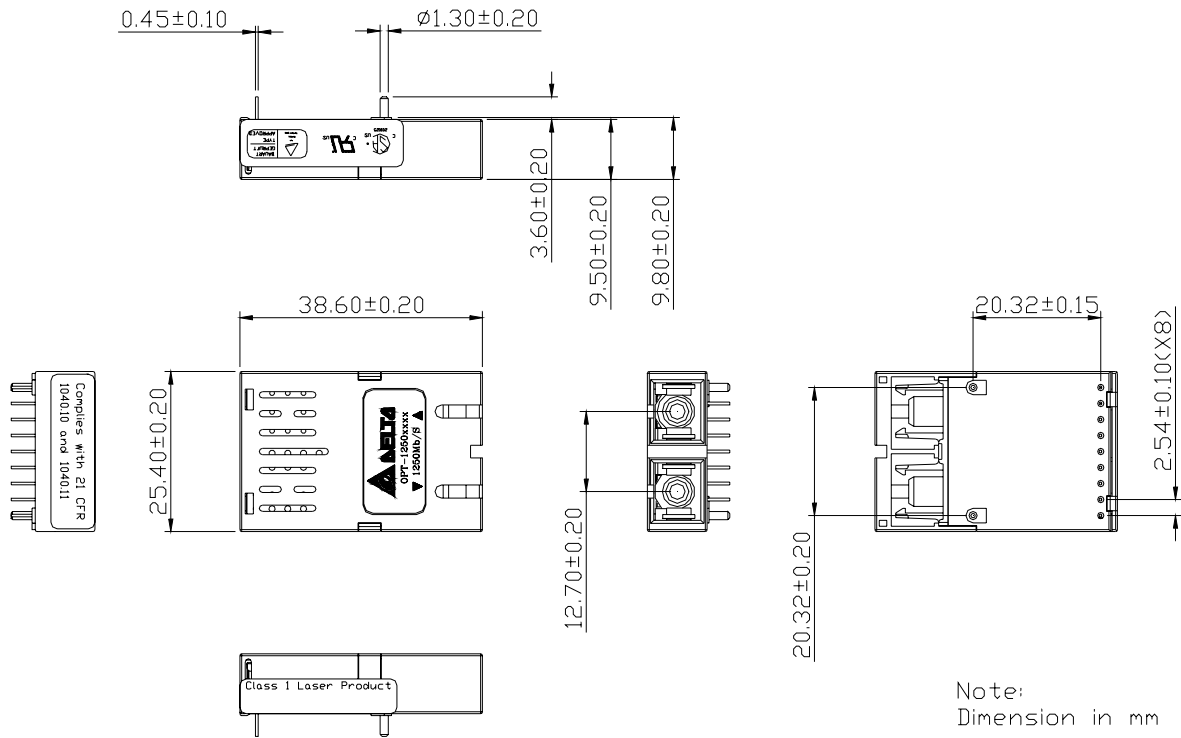

Package Outline Drawing (A type shielding)

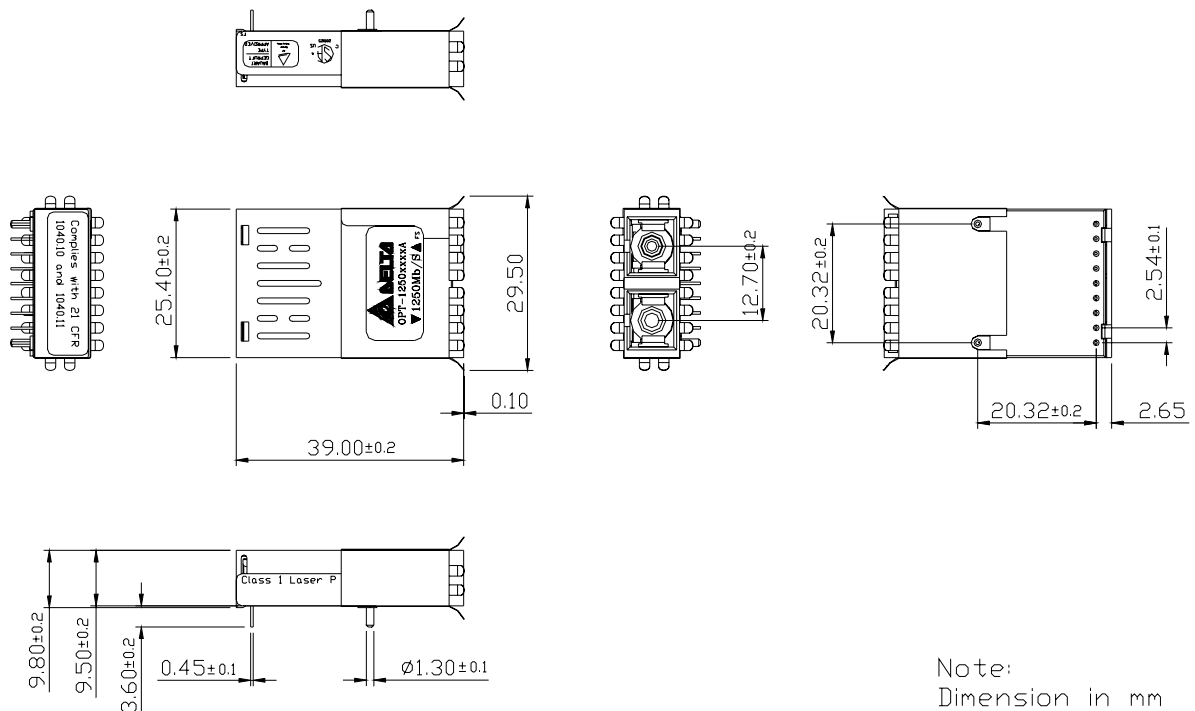

Package Outline Drawing (B type shielding)

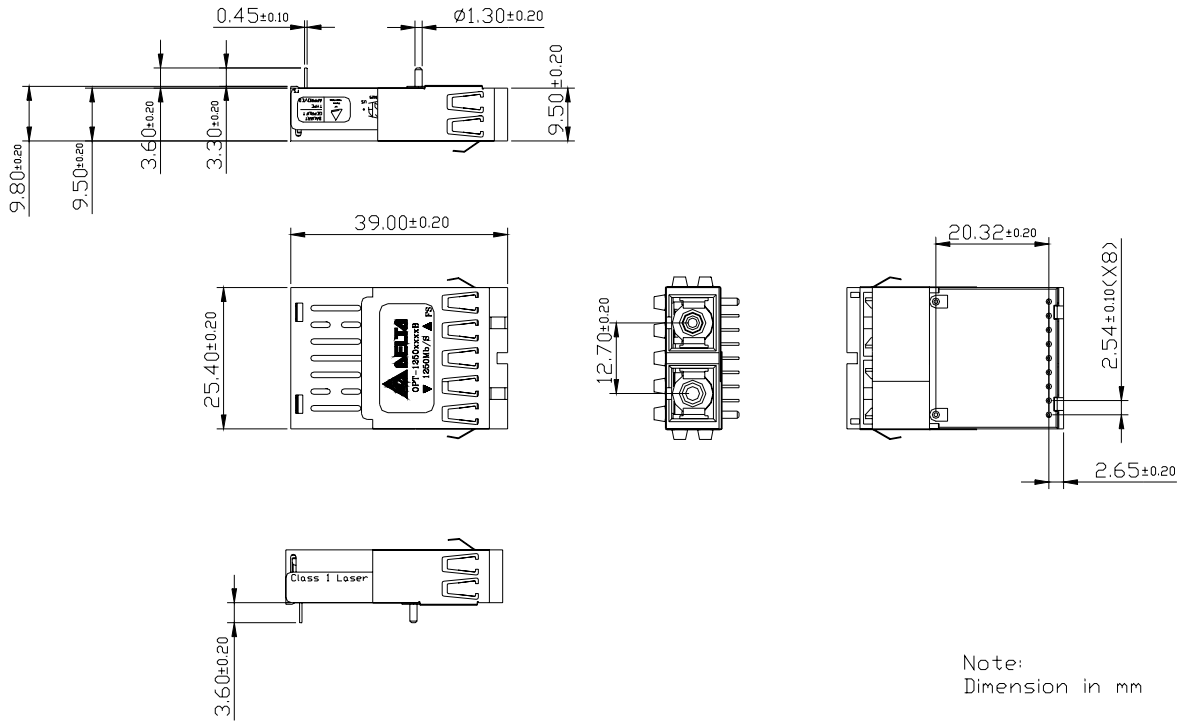

Package Outline Drawing (C type shielding)

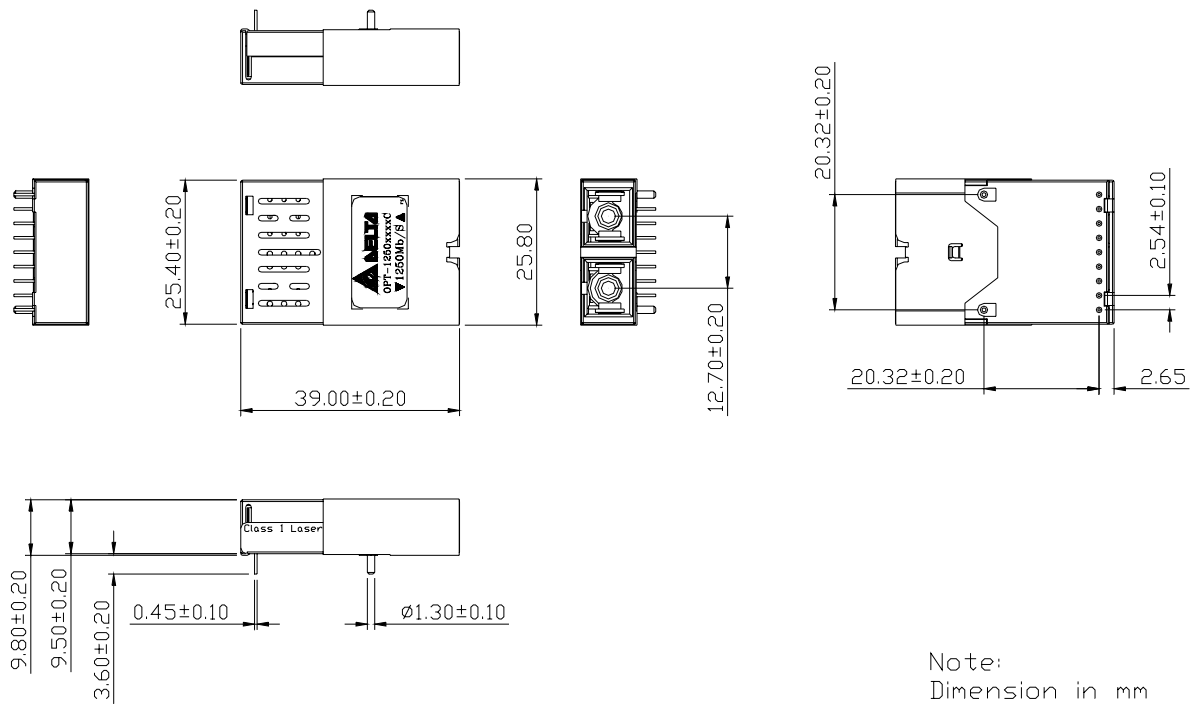

Regulatory Compliance

| Feature | Reference | Performance |
|---|---|--|
| Electromagnetic Interference (EMI) | FCC Class B EN 55022 Class B (CISPR 22A) | (1) Satisfied with electrical characteristics of product spec. (2) No physical damage |
| Radio Frequency Electromagnetic Field | EN 61000-4-3 IEC 1000-4-3 | |
| Electrostatic Discharge to the Duplex LC Receptacle | EN 61000-4-2 IEC 1000-4-2 IEC 801.2 | |
| Electrostatic Discharge to the Electrical Pins | MIL-STD-883E Method 3015.7 | |
| Eye Safety | US FDA CDRH AEL Class 1 EN 60950: 2000 EN 60825-1: 1994+A11+A2 EN 60825-2: 2000 | CDRH File # 0321539-00 TUV Certificate No. R50032471 |
| Component Recognition | Underwriters Laboratories and Canadian Standards Association Joint Component Recognition for Information Technology Equipment Including Electrical Business Equipment | UL File # E239394 |

Ordering information**OPT- 1250X₁X₂X₃X₄X₅X₆X₇****X₁: Fiber****A:** Multi-mode 850nm
B: Single-mode 1310nm**X₂: Power Supply Voltage and SD Level****1:** 5.0V, PECL SD Level
2: 3.3V, PECL SD Level
4: 3.3V, TTL SD Level**X₃: Distance****F:** 500m, 50/125 μ m MMF
I: 5km, 9/125 μ m SMF
Q: 10km, 9/125 μ m SMF**X₄: Data Coupling****1:** 1x9SC DC/DC
2: 1x9SC AC/AC**X₅:****RoHS Compliant**
Blank: Non-RoHS Compliant
R: RoHS Compliant**X₆: Shielding Type****Blank:** Plastic housing
A: A type shielding
B: B type shielding
C: C type shielding**X₇:****Temperature**
Blank: 0 to +70 degree C
H: -10 to + 85 degree C