

### Features...

### Preliminary Information

- Formerly Intel's FLEXlogic (iFX) family
- High-performance programmable logic device (PLD) family
  - SRAM-based logic with shadow EPROM or FLASH memory elements fabricated on 0.6- and 0.8-micron CMOS technology
  - Logic densities from 800 usable gates (1,600 available gates) to 3,200 usable (6,400 available) gates (see Table 1)
  - Combinatorial speeds with  $t_{PD}$  as low as 10 ns
  - Counter frequencies of up to 83.3 MHz
- 4 to 16 Logic Array Blocks (LABs) linked by a 100%-connectable Programmable Interconnect Array (PIA) for improved fitting of complex designs
- 24V10 macrocell features available
  - Dual feedback on all I/O pins
  - Product-term allocation matrix supporting up to 16 product terms per macrocell
  - Programmable registers providing D, T, SR, and JK flipflop functionality with Clear, Preset, and Clock controls
  - Fast 12-bit identity compare option
- EPX880 and EPX8160 devices are fully compliant with *PCI Local Bus Specification*.

**Table 1. FLASHlogic Device Features**

Feature	EPX740	EPX780	EPX880 (1)	EPX8160
Available gates	1600	3,200	3,200	6,400
Usable gates	800	1,600	1,600	3,200
Maximum SRAM bits	5,120	10,240	10,240	20,480
Macrocells	40	80	80	160
Package options (maximum user I/O pins)	44-pin PLCC (32) 68-pin PLCC (52)	84-pin PLCC (62) 132-pin QFP (104)	84-pin PLCC (62) 160-pin QFP (104)	208-pin QFP (172)
$t_{PD}$ (ns)	10	10	10	10
$t_{CO}$ (ns)	6	6	6	6
$f_{CNT}$ (MHz)	83.3	83.3	80	80

**Note:**

(1) All data for EPX880 devices are preliminary.

## ... and More Features

- LABs can be configured as either of the following:
  - 24V10 logic block with 10 macrocells
  - 128 X 10 SRAM block
- 3.3-V or 5.0-V I/O on all devices (selectable in each LAB)
- Low Power Consumption:
  - Low-power EPX740Z and EPX780Z versions available (1 mA/MHz in standby mode; 1.0 to 1.5 mA/MHz in active mode)
  - Low-power EPX880 and EPX8160 (1 mA/MHz in standby mode; 1.5 to 2.5 mA/MHz in active mode)
- 44 to 208 pins available in plastic J-lead (PLCC) and quad flat pack (QFP) packages (see Table 1)
- Open-drain output option
- JTAG IEEE 1149.1-compatible test port supporting:
  - Boundary-scan testing (BST)
  - In-circuit reconfigurability (ICR)
  - In-system programmability (ISP)
- Programmable Security Bit for total protection of proprietary designs
- Supported by industry-standard design and programming tools from Altera and other vendors

## General Description

Formerly Intel's FLEXlogic (iFX) device family, FLASHlogic devices are SRAM-based devices with shadow EPROM (EPX740, EPX780) or shadow FLASH (EPX880, EPX8160) memory elements. Fabricated on advanced 0.6- and 0.8-micron CMOS technology, FLASHlogic devices provide from 800 to 3,200 usable gates, pin-to-pin delays as fast as 10 ns, and counter speeds of up to 83.3 MHz. Table 2 shows the available speed grades for FLASHlogic devices.

Device	Available Speed Grades					Notes (1), (2)
	-10Z	-10	-12	-15Z	-15	
EPX740	✓	✓	✓	✓	✓	
EPX780	✓	✓	✓	✓	✓	
EPX880		✓ (3)	✓ (3)			
EPX8160		✓	✓			

### Notes:

- (1) The speed grade number after the dash refers to  $t_{PD}$  in ns.
- (2) The Z after the speed grade indicates a low-power device.
- (3) Information for this speed grade is preliminary.

FLASHlogic devices have a unique combination of features that is ideal for a variety of applications, including communications and bus interface controllers. They provide low power consumption and user-selectable 5.0-V and 3.3-V outputs. Therefore, they are good candidates for mixed-voltage applications such as portable and embedded systems.

FLASHlogic device architecture supports 100% TTL emulation and high-density integration of SSI, MSI, and LSI logic functions. It easily integrates multiple programmable logic devices ranging from PALs, GALs, and 22V10s to MACH, pLSI, and FPGA devices. With speed, density, and I/O resources comparable to commonly used masked gate arrays, FLASHlogic devices are ideal for gate array prototyping and PC applications. In addition, the -10 speed grade of the EPX880 and EPX8160 devices are PCI-compliant.

FLASHlogic devices are available in a range of packages, including plastic J-lead chip carrier (PLCC) and plastic quad flat pack (PQFP) packages.

FLASHlogic devices contain 4 to 16 Logic Array Blocks (LABs) linked by a Programmable Interconnect Array (PIA). Each LAB can be defined either as a 24V10 logic block of 10 macrocells or as a 128 × 10 SRAM block. When defined as a 24V10 logic block, all 10 macrocells have a programmable-AND/allocatable-OR array and a configurable register with independently programmable Clock, Clear, and Preset functions. To build complex logic functions, product-term allocation allows up to 16 product terms for a single macrocell.

FLASHlogic devices provide dedicated pins compliant with the JTAG IEEE 1149.1 specification. The JTAG pins support boundary-scan testing, in-circuit reconfigurability (ICR), and in-system programmability (ISP). ICR and ISP offer the designer greater flexibility in prototyping new designs. These features make FLASHlogic devices ideal for applications in which the final configuration is not fixed.

FLASHlogic devices are supported by industry-standard PC- and workstation-based EDA tools, including the Altera PLDshell Plus development system. In addition, MAX+PLUS II currently provides programming-only support for FLASHlogic devices; full-compilation support will be available in the second half of 1995.

## Functional Description

FLASHlogic device architecture includes the following elements:

- Logic Array Blocks
  - 24V10 configuration
  - SRAM configuration
- Programmable Interconnect Array
- I/O control blocks

Figure 1 shows the block diagram of the device architecture, which consists of LABs linked by a 100%-connectable PIA.

**Figure 1. FLASHlogic Architecture**

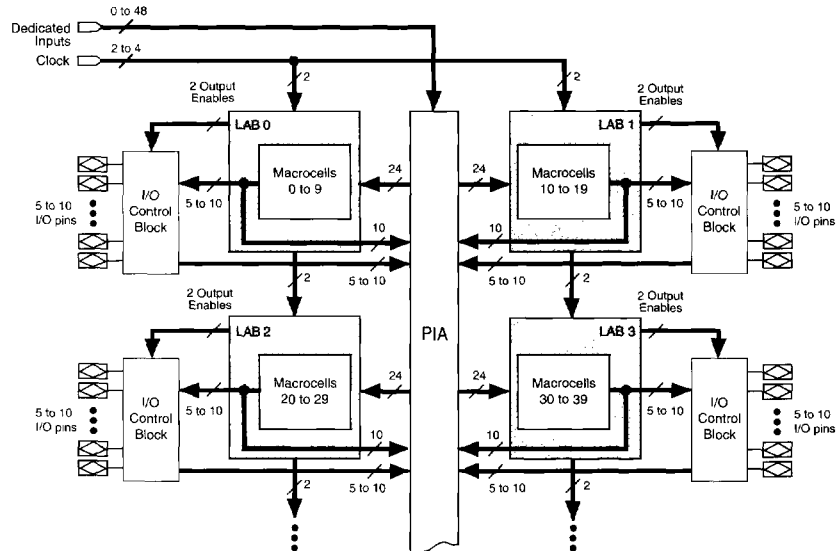

## Logic Array Block

FLASHlogic device architecture is based on high-performance, flexible Logic Array Blocks (LABs). Each LAB can be configured as a 24V10 logic block or as a  $128 \times 10$  SRAM block. The LABs are linked via the PIA, which is fed by all dedicated inputs, I/O pins, and either macrocells (in 24V10 configuration) or SRAM outputs (in SRAM configuration). Each LAB is fed by 24 signals from the PIA and 2 global Clocks.

### 24V10 Configuration

When the LAB is configured as a 24V10 block, each block contains the following elements:

- 10 macrocells
- 12-bit identity comparator
- 2 global Clocks
- I/O logic
- Control logic for array Clocks and for Clear, Preset, and Output Enable signals

Figure 2 shows a diagram of the LAB configured as a 24V10 logic block.

**Figure 2. LAB in 24V10 Configuration**

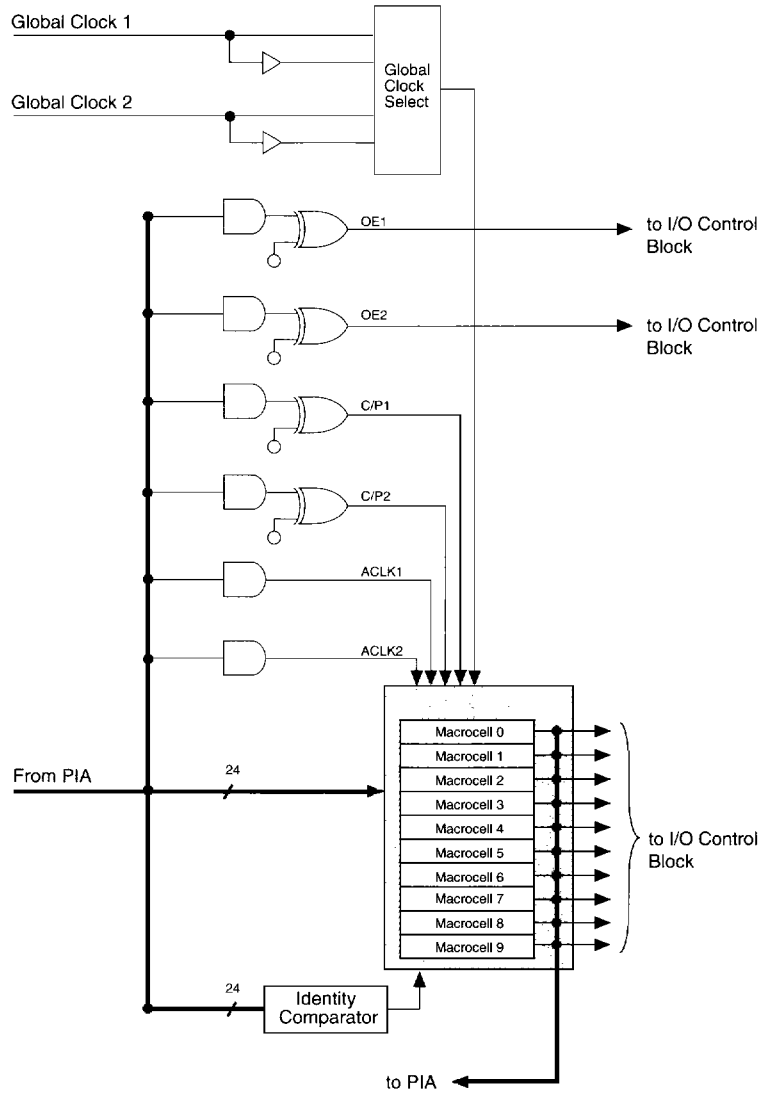

### Macrocells

Each FLASHlogic macrocell can be individually configured for either sequential or combinatorial logic operation. The macrocell consists of three functional blocks: the logic array, the product-term allocation circuit, and the programmable register. See Figure 3.

**Figure 3. FLASHlogic Macrocell**

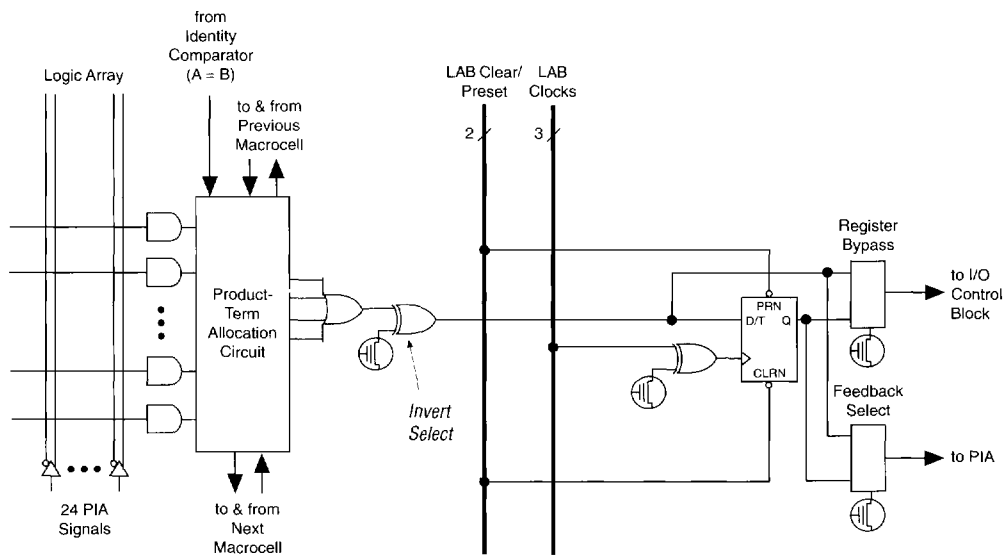

Combinatorial logic is implemented in the logic array. Within the logic array, product terms are grouped into 2 sets of 2 product terms per macrocell. Each macrocell can borrow from its adjacent macrocells to increase the total number of product terms per macrocell to a maximum of 8. In addition, the macrocells located at the ends of each LAB have access to additional product terms and can support up to 16 product-term equations. The performance of each macrocell is uniform regardless of whether 2 or 16 product terms are used. Figure 4 shows the flexible product-term-allocation circuit.

In registered functions, each macrocell flipflop can be individually programmed to implement D, T, JK, or SR operation with programmable Clock, Preset, and Clear controls. If necessary, the register can be bypassed for combinatorial operation.

Figure 4. LAB Product-Term Allocation

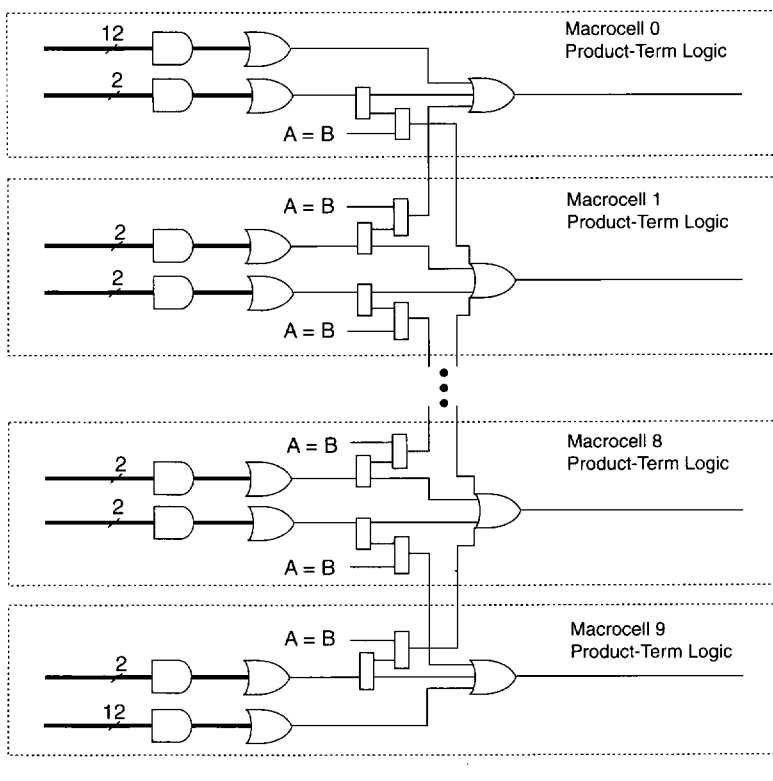

Each LAB supports a global Clock and two array Clock signals. Global clocking is provided by either of two global clock signals or two delayed versions of these signals. Array clocking is provided by two LAB product terms. Each register in the LAB can then be clocked by the true or the complement of any two of these three Clock signals.

Each programmable register can be clocked in three different modes:

- Synchronous mode, by either of two global Clock signals. This mode achieves the fastest Clock-to-output performance.
- Delayed synchronous mode, by either of two global Clock signals with an added local delay (within the LAB).
- Array mode, by either of two array Clocks implemented with a product term. In this mode, the register can be clocked by signals from buried macrocells.

These clocking modes give FLASHlogic devices more timing flexibility enabling the designer to vary the setup time, hold time, and Clock-to-output time of each register. See Table 3. These modes are particularly useful for integrating devices with short-setup-time microprocessors, such as a Pentium microprocessor.

**Table 3. EPX780-10 Sample Clocking Modes**

<b>Clock Mode</b>	<b>Setup Time</b>	<b>Hold Time</b>	<b>Clock-to-Output Time</b>	<b>Unit</b>
Synchronous	6	0	6	ns
Delayed Synchronous	4.5	2	8	ns
Array	2	5	12.5	ns

Each register also supports array Preset and Clear functions. These functions are driven by product terms and can be inverted. See Figure 2 on page 225 for a diagram of this logic.



### Comparator Circuit

Each LAB also provides a comparator circuit that compares up to 12 pairs of inputs within the  $t_{PD}$  of the device. The product-term allocation matrix allows any one of the ten macrocells in the LAB to use the output of the comparator circuit. See Figure 5.

**Figure 5. 12-Bit Identity Compare Logic**

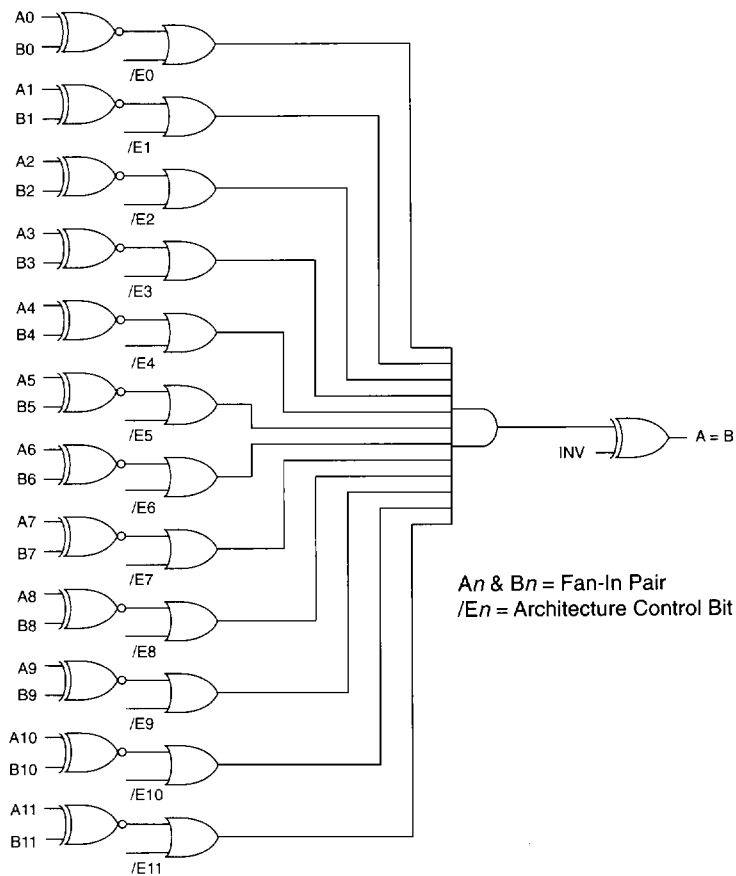

## SRAM Configuration

Each FLASHlogic LAB can be configured as a  $128 \times 10$  (128 words by 10 bits) SRAM block, as shown in Figure 6. The SRAM block can be defined with either a bidirectional I/O data bus or with separate input and output data buses.

Figure 6. LAB in SRAM Configuration

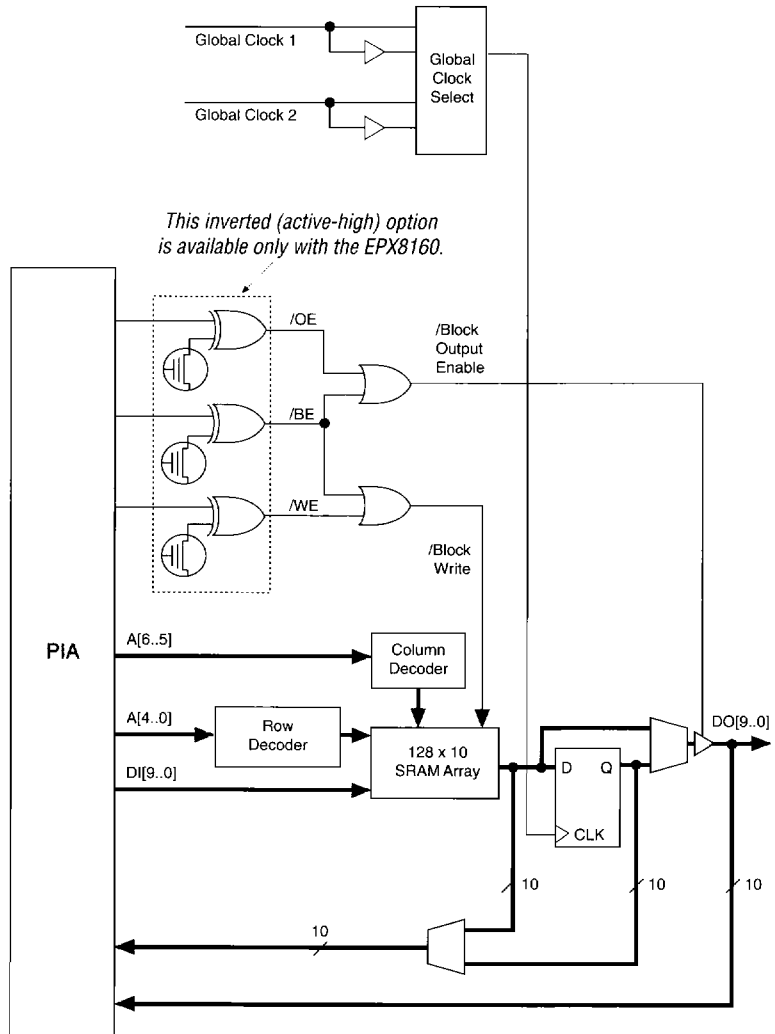

The SRAM is accessed using 24-signal fan-in: 7 bits are for address information; 10 bits are for data-in; 3 bits are for  $\overline{\text{BE}}$  (Block Enable),  $\overline{\text{WE}}$ , and  $\overline{\text{OE}}$  controls, as shown in Table 4.

Inputs			Cycle	I/O Pins
$\overline{\text{BE}}$	$\overline{\text{WE}}$	$\overline{\text{OE}}$		
1	X	X	None	Disabled
0	1	1	Read	Disabled
0	1	0	Read	Enabled
0	0	1	Write	Disabled
0	0	0	Write	Enabled

During power-up, the SRAM memory elements are initialized by on-chip, nonvolatile configuration cells. During operation, the SRAM contains a copy of the information contained in the nonvolatile configuration cells, unless other data is written to these blocks. Therefore, the SRAM block can be used as read-only memory (ROM).

When a LAB is configured as SRAM, all product terms are used as SRAM blocks and cannot be used for regular macrocell logic. Multiple LABs can be cascaded to create larger SRAM blocks, thereby increasing the width or depth of the memory.

## Programmable Interconnect Array

Signals are routed between LABs by the 100%-connectable Programmable Interconnect Array (PIA). This global bus connects any signal source to any destination on the device. All dedicated pins, I/O pins, and macrocell outputs feed into the PIA, and are accessible to all LABs. The high degree of connectivity and efficient resource management between LABs minimizes routing problems during design debugging.

The routing delays of channel-based routing schemes in masked or field-programmable gate arrays (FPGAs) are cumulative, variable, and path-dependent. In contrast, the FLASHlogic PIA has a fixed delay. Therefore, the PIA eliminates skew between signals, making timing and performance easy to predict.

## I/O Control Blocks

The I/O control block allows each I/O pin to be individually configured for input, output, or bidirectional operation. All I/O pins have a tri-state buffer that is either individually controlled by one of the two local LAB Output Enable signals generated within each LAB, or directly connected to GND or  $V_{CC}$ . Figure 7 shows the I/O control block for FLASHlogic devices.

**Figure 7. I/O Control Block for FLASHlogic Devices**

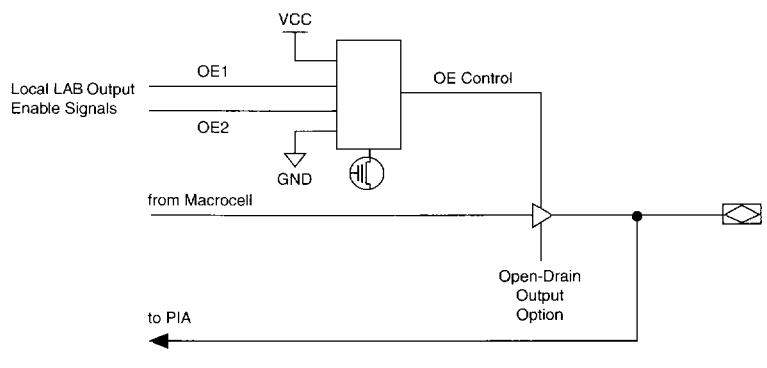

When the tri-state buffer control is connected to GND, the output is tri-stated (high-impedance) and the I/O pin can be used as a dedicated input. When the tri-state buffer control is connected to  $V_{CC}$ , the output is enabled.

The FLASHlogic architecture provides dual I/O feedback in which macrocell and pin feedbacks are independent. When an I/O pin is configured as an input, the associated macrocell can be used for buried logic.

## Input Configuration

Device inputs, as well as I/O pins that are used as inputs, can be optimized for minimum standby current during either CMOS or TTL operation by using the `CMOS_LEVEL` keyword (for 5.0-V CMOS inputs) and the `TTL_LEVEL` keyword (for TTL or 3.3-V CMOS inputs) available in the PLDasm design language supported by PLDshell Plus. `TTL_LEVEL` is the default condition for PLDasm.

## Output Configuration

FLASHlogic device outputs can be configured to meet a variety of system-level requirements.

### 3.3 V or 5.0 V Operation

The pins in an I/O control block can operate at 3.3 V or 5.0 V. This functionality enables the designer to mix 3.3-V outputs and 5.0-V inputs if the appropriate  $V_{CCO}$  pins are tied to a 3.3-V power supply. FLASHlogic devices require a  $V_{CC}$  of 5.0 V for normal operation. However, the  $V_{CCO}$  pin associated with each LAB pair can be connected to either 5.0 V or 3.3 V to control the output voltages of the I/O pins of that LAB pair. This feature allows FLASHlogic devices to be used in mixed-voltage systems. For example, the devices can be used as an interface between a 3.3-V CPU and 5.0-V peripheral logic.

Power sequencing is required when any or all LABs operate at 3.3-V levels. In other words, the voltage levels of the 5.0-V source must be greater than or equal to the 3.3-V source during power-up and power-down.

### Open-Drain Output Option

FLASHlogic devices can be configured to provide an optional open-drain output for each I/O pin. If desired, complex equations can be implemented using multiple open-drain outputs with an externally supplied pull-up resistor to emulate an additional OR plane.

### CMOS-Compatible Outputs

A weak pull-up resistor is provided for CMOS-compatible outputs. This resistor is always active in both 3.3-V and 5.0-V modes.

### I/O Pull-Up Resistor

EPX8160 devices contain active-weak pull-up resistors on the I/O pins that hold the I/O at a logic high during power-up, reconfiguration, and erase/program cycles. This resistor is disabled during normal device operation to reduce power consumption. Dedicated inputs do not have active pull-up resistors.

## High Drive I/O

EPX880 and EPX8160 output buffers are designed specifically for applications requiring high drive current. These buffers enable the devices to drive a bus (including PCI) and at the same time provide 10-ns pin-to-pin performance, eliminating the need for external buffers and their associated delays.

## PCI Compliance

EPX880 and EPX8160 5.0-V output buffers are designed to meet the current-vs.-voltage specifications for PCI. EPX880-10 and EPX8160-10 devices also offer a predictable, 10-ns pin-to-pin propagation delay, a 6-ns Clock-to-signal valid delay, and a 6.5-ns synchronous setup time to meet the timing demands of PCI applications. To support bidirectional PCI signals, two Output Enable product terms are provided in each LAB, for a total of 32 in the device.



Go to *Application Note 41, (PCI Bus Applications in Altera Devices)* for more information on using EPX8160 devices in PCI applications.

## JTAG Operation

FLASHlogic devices support the JTAG IEEE 1149.1 standard boundary-scan testing (BST). The JTAG BST architecture enables fault-isolation testing of board designs at the device level, enhances production testing and field repair, and is ideal for fault-tolerant applications.

FLASHlogic BST support consists of an instruction register, a data register, scan cells, and associated logic, all of which are accessed through the Test Access Port (TAP). The TAP interface consists of three inputs—Test Mode Select (TMS), Test Data Input (TDI), and Test Clock Input (TCK)—and one output, Test Data Output (TDO).

EPX740, EPX780, and EPX880 devices each contain one JTAG TAP controller; EPX8160 devices contain two JTAG TAP controllers. The JTAG TAP controllers support group (partial) reconfiguration, group reprogramming, and boundary-scan testing. Figure 8 shows the internal connection of the JTAG TAP controllers.

Figure 8. JTAG Connections of TAP Controllers

EPX740, EPX780 & EPX880

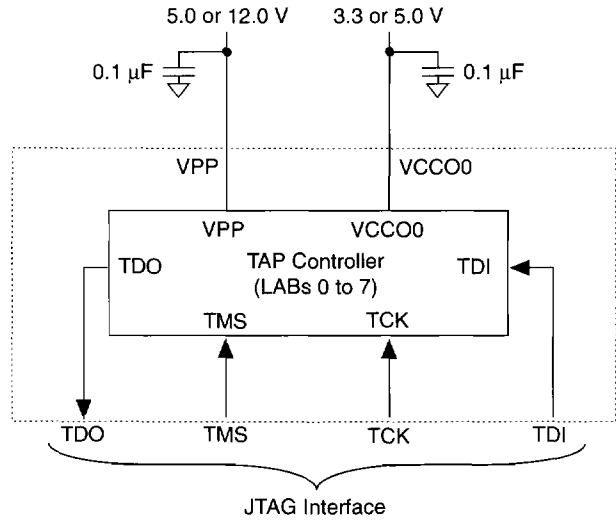

EPX8160

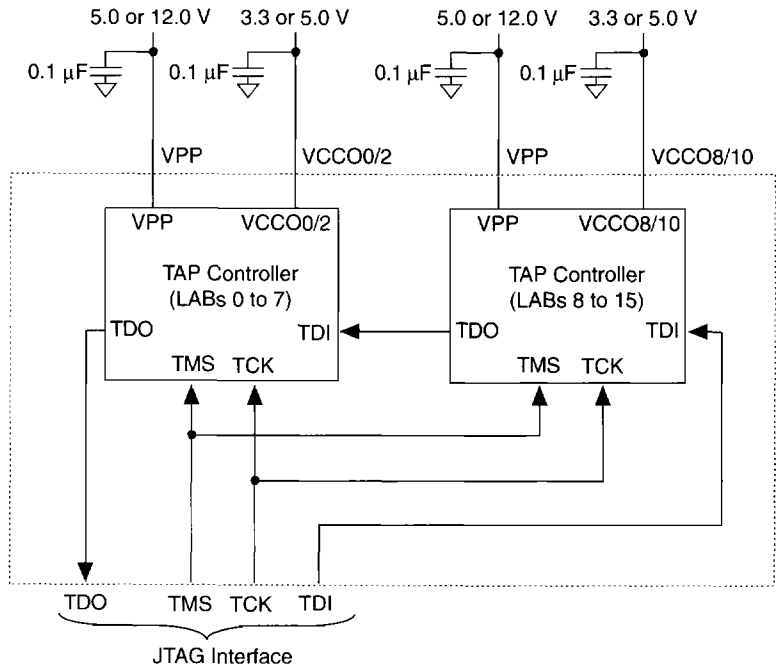

In FLASHlogic devices, the boundary-scan I/O pins are linked to form a shift register chain for all active pins. This chain provides a path that can be used to shift boundary-scan data into and out of the device.

For example, a continuity test can be performed between two JTAG devices on a circuit board by placing a known value on the output buffers of one device and observing the input buffers of the other device. The same technique can also be used to perform in-circuit functional testing of FLASHlogic devices for prototyping new system designs.

The 4-pin JTAG test interface is also used for standard programming, in-circuit reconfiguration, and in-system programming.

### Boundary-Scan Instructions

The FLASHlogic boundary-scan instruction register (IR) supports the instruction opcodes and extended instruction opcodes used for the Program/Verify modes. (See Table 5).

<b>Name</b>	<b>IR Opcode (Binary) MSB..LSB</b>	<b>Description</b>
EXTEST	00000	The EXTEST instruction drives the output pins to the values contained in the boundary-scan cells. The instruction tests the external circuitry used for printed circuit board interconnects.
BYPASS	11111	The BYPASS instruction selects the one-bit bypass register (BPR) to be connected to $T_{DI}$ and $T_{DO}$ .
SAMPLE/PRELOAD	00001	The SAMPLE/PRELOAD instruction is used for two functions: 1) to allow a snapshot of the values of the device pins in an unobtrusive manner, and 2) to preload data onto the device pins that are driven to the system circuit board when executing the EXTEST instruction.
IDCODE	00010	The IDCODE instruction selects the ID code register to be connected to $T_{DI}$ and $T_{DO}$ , allowing the ID code to be serially shifted out of $T_{DO}$ .
UESCODE	10110	The UESCODE instruction selects the User Electronic Signature (UES) register to be connected to $T_{DI}$ and $T_{DO}$ , allowing the UES code to be serially shifted out of $T_{DO}$ .
HIZ	01000	The HIZ instruction sets all I/O pins to a high-impedance state.



## ICR & ISP

FLASHlogic devices support in-circuit reconfigurability (ICR). Using the 4-pin JTAG test port, a new configuration can be downloaded to the SRAM by simply shifting the new data into the device. Device reconfiguration can be repeated as many times as desired during prototyping.

Once the design is finalized, it can be programmed into the shadow EPROM or FLASH cells so that the configuration is not lost, even when the power is turned off. This capability is known as in-system programmability (ISP). Devices are programmed in-system using the JTAG test port and the programming voltage pins ( $V_{pp}$ ). EPROM-based devices can be programmed once; FLASH-based devices can be programmed up to 100 times.



Go to *Application Note 45 (Configuring FLASHlogic Devices)* for more information on ICR.

## Design Security

FLASHlogic devices contain a programmable Security Bit that controls access to the data programmed into the device. Once this Security Bit is set, the design cannot be read from the nonvolatile cells or the SRAM. The state of the nonvolatile Security Bit at power-up determines whether data programmed into the device can be accessed and changed by in-circuit reconfiguration.

## Timing Model

FLASHlogic devices have fixed internal delays that allow the user to determine the worst-case timing for any design. Device timing can be analyzed with a variety of industry-standard EDA simulators and timing analyzers. Industry-standard EDA tools provide timing simulation, point-to-point delay prediction, and detailed analysis for system-level performance evaluation. (Full device support via MAX+PLUS II is planned for the second half of 1995.) External timing parameters represent pin-to-pin timing delays. Switching waveforms for these timing parameters (including SRAM read and SRAM write cycles) are shown in Figure 9.

**Figure 9. Switching Waveforms (Part 1 of 2)**

**Combinatorial Mode**

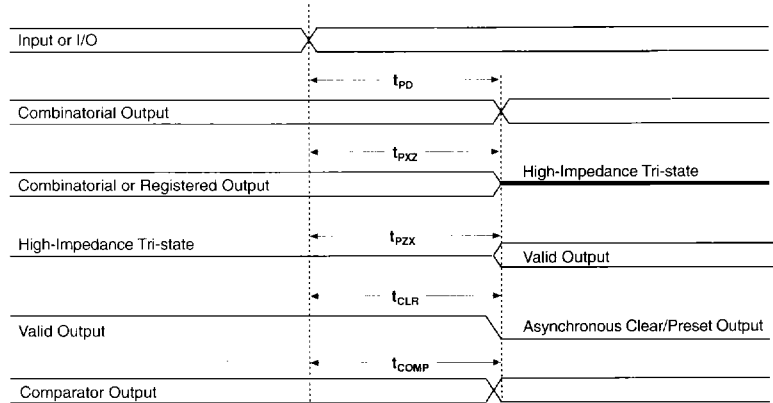

**Registered Mode**

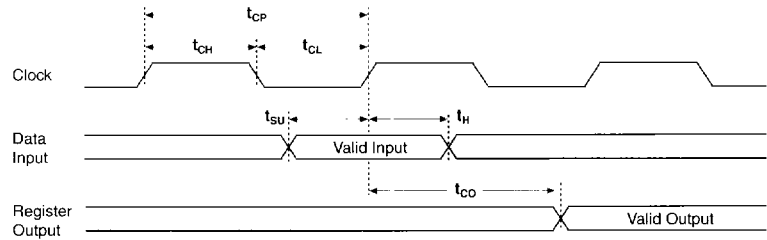
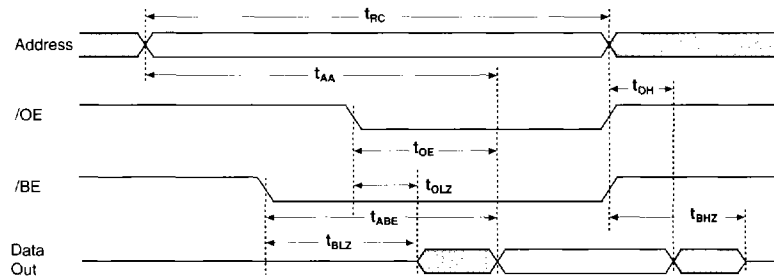
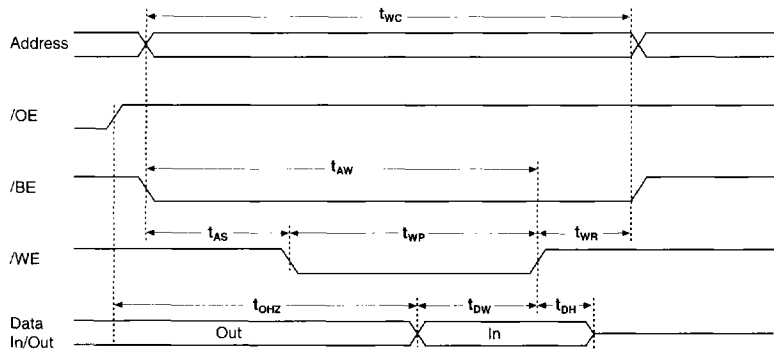

Figure 9. Switching Waveforms (Part 2 of 2)

## SRAM Read Cycle



## SRAM Write Cycle 1 (/WE-Controlled Timing)



## SRAM Write Cycle 2 (/BE-Controlled Timing)

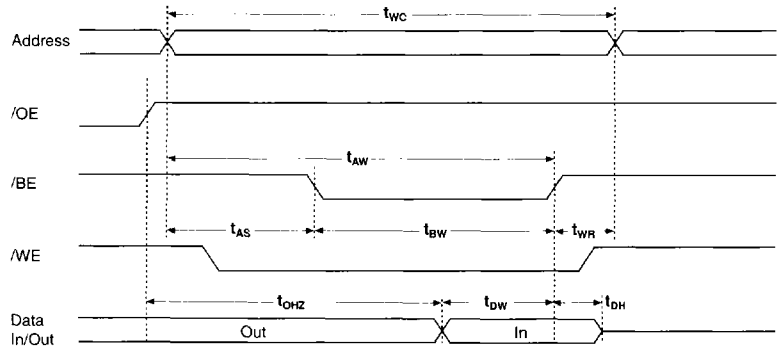

## Generic Testing

FLASHlogic devices are fully functionally tested and guaranteed. Complete testing of each programmable FLASH or EPROM bit and all internal logic elements ensures 100% programming yield. AC test measurements are taken under conditions equivalent to those shown in Figure 10. Test patterns can be used and erased during early stages of the device production flow.

**Figure 10. FLASHlogic AC Test Conditions**

*Power-supply transients can affect AC measurements. For accurate measurements, avoid simultaneous transitions of multiple outputs. Do not perform threshold tests under AC conditions. Large-amplitude, fast ground-current transients normally occur as the device outputs discharge the load capacitances. When these transients flow through the parasitic inductance between the device ground pin and the test system ground, they can significantly reduce observable noise immunity. Numbers in parentheses are for EPX880 and EPX8160 devices.*

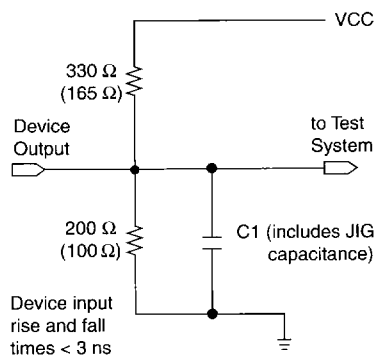

## Software Support

FLASHlogic devices are supported by industry-standard PC- and workstation-based EDA tools, including the Altera PLDshell Plus development system. In addition, MAX+PLUS II currently provides programming-only support; full compilation support is planned for the second half of 1995. See the *MAX+PLUS II Programmable Logic Development System & Software Data Sheet* in this data book for more information.



Go to the *PLDshell Plus/PLDasm User's Guide* for information on programming FLASHlogic devices using PLDshell.

Third-party software support is provided by the following vendors:

<b>Vendor</b>	<b>Software</b>	<b>Description</b>
Data I/O	ABEL	Design software that describes and implements logic designs
Data I/O	Synario 2.0	Integrated text and graphic design and simulation environment
Logical Devices	CUPL	High-level, universal design software package
Minc	PLDesigner-XL(R)	Design tool for all types of programmable logic with automatic device selection, automatic partitioning, and functional simulation
OrCAD	PLD Tools and Schematic Design Tool	Includes schematic entry, test vector generation, and multiple forms of input
OrCAD	Verification and Simulation Tool	Series of software tools for performing timing-based simulation of designs
Viewlogic	Workview, PRO Series, and Powerview	Integrated schematic capture and simulation environments

Simulation models are provided by the following vendors:

- Synopsys SmartModel—Device model support for behavioral simulation through a variety of simulators
- Viewlogic—Simulation model for Viewlogic verification tools

## Device Programming

FLASHlogic devices can be programmed with MAX+PLUS II software on 486- or Pentium-based PCs using an Altera Logic Programmer card, the Master Programming Unit (MPU), and the appropriate device adapter. The MPU performs continuity checking to ensure adequate electrical contact between the adapter and the device. See the *Altera Programming Hardware Data Sheet* in this data book for more information.

FLASHlogic devices can also be programmed in-system with PLDshell Plus software using Altera's FLASHlogic Download Cable (PL-FLDLC). Data I/O and other programming hardware manufacturers also provide programming support for FLASHlogic devices. See *Programming Hardware Manufacturers* in this data book for more information.

## QFP Carrier & Development Socket

FLASHlogic devices in QFP packages with 160 or more pins can be ordered in plastic carriers to protect the fragile QFP leads. The carrier can be used with a prototype development socket and programming hardware available from Altera. This carrier makes it possible to program, test, erase, and reprogram a device without exposing the leads to mechanical stress.



Go to the *QFP Carrier & Development Socket Data Sheet* in this data book for more information.

### Absolute Maximum Ratings *Note (1)*

Symbol	Parameter	Conditions	Min	Max	Unit
$V_{CC}$	Supply voltage	With respect to GND, <i>Note (2)</i>	-2.0	7.0	V
$V_{PP}$	Programming supply voltage: EPX740 & EPX780		-2.0	13.5	V
$V_{PP}$	Programming supply voltage: EPX880 & EPX8160		-2.0	12.6	V
$V_I$	DC input voltage		-0.5	$V_{CC} + 0.5$	V
$T_{STG}$	Storage temperature	No bias	-65	150	°C
$T_{AMB}$	Ambient temperature	Under bias	-10	85	°C
$T_J$	Junction temperature	Under bias		150	°C

### Recommended Operating Conditions

Symbol	Parameter	Conditions	Min	Max	Unit
$V_{CC}$	Supply voltage: 5.0 V		4.75	5.25	V
$V_{CCO}$	Output supply voltage: 5.0 V		4.75	5.25	V
$V_{CCO}$	Output supply voltage: 3.3 V		3.0	3.6	V
$V_I$	Input voltage		0	$V_{CC}$	V
$V_O$	Output voltage		0	$V_{CCO}$	V
$T_A$	Operating temperature	For commercial use	0	70	°C
$T_A$	Operating temperature	For industrial use	-40	85	°C
$t_R$	Input rise time			500	ns
$t_F$	Input fall time			500	ns

**DC Operating Conditions** Note (3)

Symbol	Parameter	Conditions	Min	Max	Unit
$V_{IH}$	High-level input voltage		2.0	$V_{CC} + 0.3$	V
$V_{IL}$	Low-level input voltage		-0.3	0.8	V
$V_{OH}$	5.0-V TTL high-level output voltage	EPX740 & EPX780: $I_{OH} = -4.0$ mA DC, $V_{CCO} = \text{min.}$ EPX880 & EPX8160: $I_{OH} = -16.0$ mA DC, $V_{CCO} = \text{min.}$	2.4		V
	5.0-V CMOS high-level output voltage	EPX740 & EPX780: $I_{OH} = -20$ $\mu$ A DC, $V_{CCO} = \text{min.}$ EPX880 & EPX8160: $I_{OH} = -100$ $\mu$ A DC, $V_{CCO} = \text{min.}$	$V_{CCO} - 0.2$		V
	3.3-V high-level output voltage	EPX740 & EPX780: $I_{OH} = -20$ $\mu$ A DC, $V_{CCO} = \text{min.}$ EPX880 & EPX8160: $I_{OH} = -100$ $\mu$ A DC, $V_{CCO} = \text{min.}$	$V_{CCO} - 0.2$		V
$V_{OL}$	5.0-V low-level output voltage	EPX740 & EPX780: $I_{OL} = 12$ mA DC, $V_{CCO} = \text{min.}$ EPX880 & EPX8160: $I_{OL} = 24$ mA DC, $V_{CCO} = \text{min.}$		0.45	V
	3.3-V low-level output voltage	EPX740 & EPX780: $I_{OL} = 20$ $\mu$ A DC, $V_{CCO} = \text{min.}$ EPX880 & EPX8160: $I_{OL} = 12$ mA DC, $V_{CCO} = \text{min.}$		0.2	V
$I_I$	Input leakage current	$V_{CCO} = \text{max.}$ , $GND < V_{IN} < V_{CCO}$ . Note (4)	-10	10	$\mu$ A
$I_{OZ}$	Output leakage current	EPX740 & EPX780: $V_{CCO} = \text{max.}$ , $GND < V_{OUT} < V_{CCO}$	-50	50	$\mu$ A
		EPX880 & EPX8160: $V_{CCO} = \text{max.}$ , $V_{OUT} = V_{CCO}$	-50	50	$\mu$ A
		EPX880 & EPX8160: $V_{CCO} = \text{max.}$ , $V_{OUT} = GND$	-100	100	$\mu$ A
$I_{SC}$	Output short circuit current, Note (5)	$V_{CCO} = \text{max.}$ , $V_{OUT} = 0.5$ V	-30	-120	mA

**Programming Conditions** Notes (3), (6)

Symbol	Parameter	Conditions	Min	Typ	Max	Unit
$V_{PP}$	EPX740 & EPX780: programming voltage		12.5	12.75	13.00	V
	EPX880 & EPX8160: programming voltage		11.4	12	12.6	V
$I_{PP1}$	$V_{PP}$ read current, IC current, or standby current	$V_{PP} > V_{CC}$		90	200	$\mu$ A
		$V_{PP} \leq V_{CC}$		15	40	$\mu$ A
$I_{PP2}$	EPX740 & EPX780: $V_{PP}$ programming or program verify current	$V_{PP} = V_{PPH}$ Programming in progress		50	100	mA
	EPX880 & EPX8160: $V_{PP}$ programming or program verify current	$V_{PP} = V_{PPH}$ Programming in progress		30	60	mA
$I_{PP3}$	$V_{PP}$ erase and erase verify current	$V_{PP} = V_{PPH}$		30	60	mA
$E_{CNT}$	Erase and reprogram count limit				100	

***I<sub>CC</sub> Supply Current Values*** Note (7)

Symbol	Parameter	Conditions	EPX740	EPX740Z	EPX780	EPX780Z	EPX880	EPX8160	Unit
$I_{CC1}$	$V_{CC}$ supply current, (standby, typical)	$V_{CC} = \text{Max.}$ , $V_{IN} = V_{CC}$ or GND, standby mode Note (8)	20	1	20	1	1	1	mA
$I_{CC}$	$V_{CC}$ supply current, (active, typical)	$V_{IN} = V_{CC}$ or GND, no load, Note (8)	1	1	1.5	1.5	1.5	2.5	mA/MHz

***Capacitance*** Notes (7), (9)

Symbol	Parameter	Conditions	Typ	Max	Unit
$C_{IN}$	Input pin capacitance	$V_{IN} = 2 \text{ V}$ , $f = 1.0 \text{ MHz}$	10	12	pF
$C_{I/O}$	I/O pin capacitance	$V_{OUT} = 2 \text{ V}$ , $f = 1.0 \text{ MHz}$	12	15	pF
$C_{CLK}$	Clock pin capacitance	$V_{OUT} = 2 \text{ V}$ , $f = 1.0 \text{ MHz}$	15	18	pF
$C_{VPP}$	$V_{PP}$ pin capacitance	$f = 1.0 \text{ MHz}$	12	15	pF

***Notes to tables:***

- (1) See *Operating Requirements for Altera Devices* in this data book.
- (2) The minimum DC input is  $-0.5 \text{ V}$ . During transitions, the inputs may undershoot to  $-2.0 \text{ V}$  or overshoot to  $7.0 \text{ V}$  for periods of less than  $20 \text{ ns}$  under no-load conditions.
- (3) Operating conditions:  $T_A = 0^\circ \text{ C}$  to  $70^\circ \text{ C}$ ,  $V_{CC} = 5.0 \text{ V} \pm 5\%$  for commercial use.  
 $T_A = -40^\circ \text{ C}$  to  $85^\circ \text{ C}$ ,  $V_{CC} = 5.0 \text{ V} \pm 10\%$  for industrial use.
- (4) Input leakage current on JTAG pins is tested at  $\pm 20 \mu\text{A}$ .
- (5) No more than 1 output should be tested at a time. The duration of the test should not exceed 1 second.
- (6) Typical values are for  $T_A = 25^\circ \text{ C}$ ,  $V_{CC} = 5.0 \text{ V}$ ,  $V_{PP} = 12.0 \text{ V}$ .
- (7) Typical values are for  $T_A = 25^\circ \text{ C}$ ,  $V_{CC} = 5.0 \text{ V}$ .
- (8) Measured with a 20-bit, loadable, enabled, up/down counter programmed into each LAB pair.
- (9) Capacitance measured at  $25^\circ \text{ C}$ . Sample-tested only.

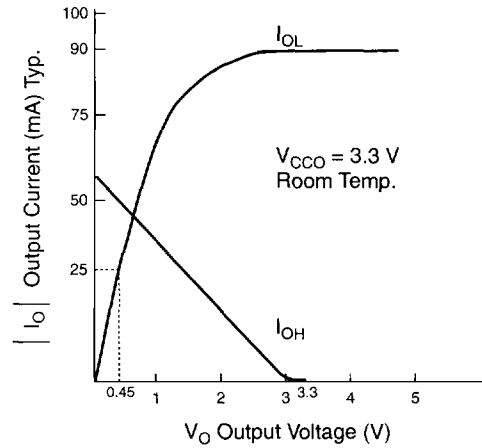
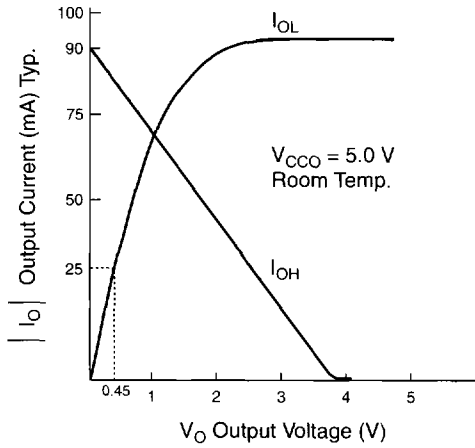

Figure 11 shows the typical output drive characteristics for FLASHlogic devices.

**Figure 11. Output Drive Characteristics of FLASHlogic Devices**

The output drive characteristics for EPX880 devices are preliminary.

**EPX740 & EPX780 Devices**



**EPX880 & EPX8160 Devices**

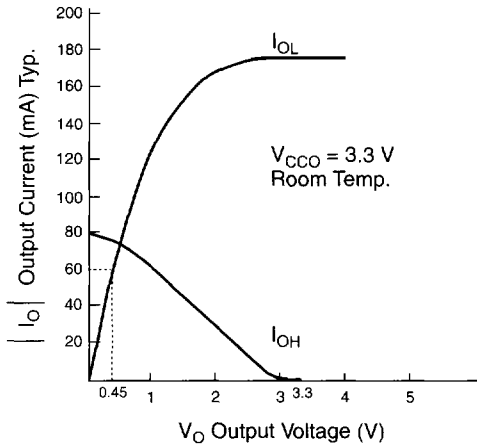
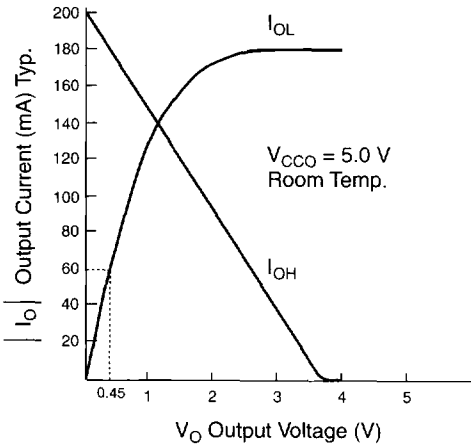

**AC Operating Characteristics: EPX740 & EPX780** Note (1)

<b>External Timing Parameters</b>			EPX740-10Z EPX740-10 EPX780-10Z EPX780-10		EPX740-12 EPX780-12 Note (2)		EPX740-15Z EPX740-15 EPX780-15Z EPX780-15		
<b>Combinatorial Mode</b>			Min	Max	Min	Max	Min	Max	Unit
<b>t<sub>PD</sub></b>	Input or I/O to output valid	C1 = 35 pF		10		12		15	ns
<b>t<sub>PZX</sub></b>	Input or I/O to output enable	C1 = 35 pF		12		15		18	ns
<b>t<sub>PXZ</sub></b>	Input or I/O to output disable	C1 = 5 pF		12		15		18	ns
<b>t<sub>CLR</sub></b>	Array output clear time			15		18		20	ns
<b>t<sub>COMP</sub></b>	Comparator input or I/O feedback to output valid			10		12		15	ns

<b>External Timing Parameters</b>			EPX740-10Z EPX780-10Z		EPX740-10 EPX780-10		EPX740-12 EPX780-12 Note (2)		EPX740-15Z EPX740-15 EPX780-15Z EPX780-15		
<b>Register Mode—Synchronous Clock</b>			Min	Max	Min	Max	Min	Max	Min	Max	Unit
<b>f<sub>MAX</sub></b>	Maximum frequency	Note (3)	100		100		80		66.7		MHz
<b>t<sub>SU</sub></b>	Input setup time		6		6		7.5		11		ns
<b>t<sub>H</sub></b>	Input hold time		0		0		0		0		ns
<b>t<sub>CH</sub></b>	Clock high time		4.5		4.5		5		7		ns
<b>t<sub>CL</sub></b>	Clock low time		4.5		4.5		5		7		ns
<b>t<sub>CP</sub></b>	Clock period		10		10		12.5		15		ns
<b>t<sub>CO1</sub></b>	Clock-to-output delay	C1 = 35 pF		6		6.5		7.5		9	ns
<b>t<sub>CNT</sub></b>	Minimum clock period			12		12.5		15		20	ns
<b>f<sub>CNT</sub></b>	Internal maximum frequency	Note (4)	83.3		80		66		50		MHz

<b>External Timing Parameters</b>			EPX740-10Z EPX780-10Z		EPX740-10 EPX780-10		EPX740-12 EPX780-12 Note (2)		EPX740-15Z EPX740-15 EPX780-15Z EPX780-15		
<b>Register Mode—Delayed Synchronous Clock</b>			Min	Max	Min	Max	Min	Max	Min	Max	Unit
<b>f<sub>MAX</sub></b>	Maximum frequency	Note (3)	92.9		92.9		74		62.5		MHz
<b>t<sub>SU</sub></b>	Input setup time		4.5		4.5		6		8		ns
<b>t<sub>H</sub></b>	Input hold time		2		2		2		2		ns
<b>t<sub>CH</sub></b>	Clock high time		4.5		4.5		5		7		ns
<b>t<sub>CL</sub></b>	Clock low time		4.5		4.5		5		7		ns
<b>t<sub>CP</sub></b>	Clock period		10.5		10.5		12.5		15		ns
<b>t<sub>CO1</sub></b>	Clock-to-output delay	C1 = 35 pF		8		8.5		10		12	ns
<b>t<sub>CNT</sub></b>	Minimum clock period			12.5		13		16		20	ns
<b>f<sub>CNT</sub></b>	Internal maximum frequency	Note (4)	80		76.9		62.5		50		MHz

<b>External Timing Parameters</b>			EPX740-10Z EPX780-10Z		EPX740-10 EPX780-10		EPX740-12 EPX780-12 <i>Note (2)</i>		EPX740-15Z EPX740-15 EPX780-15Z EPX780-15		
<b>Register Mode—Array Clock</b>											
<b>Symbol</b>	<b>Parameter</b>	<b>Conditions</b>	<b>Min</b>	<b>Max</b>	<b>Min</b>	<b>Max</b>	<b>Min</b>	<b>Max</b>	<b>Min</b>	<b>Max</b>	<b>Unit</b>
$f_{AMAX}$	Maximum frequency	<i>Note (3)</i>	80		80		66		62.5		MHz
$t_{ASU}$	Input setup time		2		2		2.5		3		ns
$t_{AH}$	Input hold time		5		5		6		6		ns
$t_{ACH}$	Clock high time		5		5		6		7		ns
$t_{ACL}$	Clock low time		5		5		6		7		ns
$t_{ACP}$	Clock period		12.5		12		66		15		ns
$t_{ACO}$	Clock-to-output delay	$C1 = 35 \text{ pF}$		12		12		14.5		17	ns
$t_{ACNT}$	Minimum clock period			13.5		14		17		20	ns
$f_{ACNT}$	Internal maximum frequency	<i>Note (4)</i>	71.4		71.4		58.8		50		MHz

<b>External Timing Parameters</b>			EPX740-10Z EPX740-10 EPX780-10Z EPX780-10		EPX740-12 EPX780-12 <i>Note (2)</i>		EPX740-15Z EPX740-15 EPX780-15Z EPX780-15		
<b>SRAM Read</b>									
<b>Symbol</b>	<b>Parameter</b>	<b>Conditions</b>	<b>Min</b>	<b>Max</b>	<b>Min</b>	<b>Max</b>	<b>Min</b>	<b>Max</b>	<b>Unit</b>
$t_{RC}$	Read cycle time		15		20		20		ns
$t_{AA}$	Address access time			15		20		20	ns
$t_{ABE}$	Block enable access time			15		20		20	ns
$t_{OE}$	Output enable to output valid	<i>Note (5)</i>		12		15		15	ns
$t_{OH}$	Output hold from address change		2		3		3		ns
$t_{BLZ}$	Block enable to output in low impedance	<i>Note (5)</i>	3		5		5		ns
$t_{BHZ}$	Block disable to output in high impedance	$C1 = 5 \text{ pF}$ , <i>Note (5)</i>		10		15		15	ns
$t_{OLZ}$	Output enable to output in low impedance	<i>Note (5)</i>	3		5		5		ns

<b>External Timing Parameters</b>			EPX740-10Z EPX740-10 EPX780-10Z EPX780-10		EPX740-12 EPX780-12 <i>Note (2)</i>		EPX740-15Z EPX740-15 EPX780-15Z EPX780-15		
<b>Register SRAM Read—Synchronous</b>									
<b>Symbol</b>	<b>Parameter</b>		<b>Min</b>	<b>Max</b>	<b>Min</b>	<b>Max</b>	<b>Min</b>	<b>Max</b>	<b>Unit</b>
$t_{SU}$	Input or I/O setup time to clock		11.5		13		16		ns
$t_H$	Input or I/O hold time to clock		0		0		0		ns
$t_{CO1}$	Clock-to-output valid			6.5		7.5		9	ns
$t_{CL}$	Clock low time		4.5		5.5		7		ns
$t_{CH}$	Clock high time		4.5		5.5		7		ns
$t_{CP}$	Clock period		15		17		20		ns

<b>External Timing Parameters</b>		EPX740-10Z EPX740-10 EPX780-10Z EPX780-10		EPX740-12 EPX780-12 <i>Note (2)</i>		EPX740-15Z EPX740-15 EPX780-15Z EPX780-15		
<b>Register SRAM Read—Delayed Synchronous</b>		Min	Max	Min	Max	Min	Max	Unit
<b>t<sub>SU</sub></b>	Input or I/O setup time to clock	10		11		13		ns
<b>t<sub>H</sub></b>	Input or I/O hold time to clock	2		2		2		ns
<b>t<sub>CO1</sub></b>	Clock-to-output valid		8.5		9.5		12	ns
<b>t<sub>CL</sub></b>	Clock low time	4.5		5.5		7		ns
<b>t<sub>CH</sub></b>	Clock high time	4.5		5.5		7		ns
<b>t<sub>CP</sub></b>	Clock period	15		17.5		20		ns

<b>External Timing Parameters</b>			EPX740-10Z EPX740-10 EPX780-10Z EPX780-10		EPX740-12 EPX780-12 <i>Note (2)</i>		EPX740-15Z EPX740-15 EPX780-15Z EPX780-15		
<b>SRAM Write</b>			Min	Max	Min	Max	Min	Max	Unit
Symbol	Parameter	Conditions	Min	Max	Min	Max	Min	Max	Unit
<b>t<sub>WC</sub></b>	Write cycle time		15		18		20		ns
<b>t<sub>BW</sub></b>	Block enable to end of write		10		12		13		ns
<b>t<sub>AW</sub></b>	Address valid to end of write		13		15		17		ns
<b>t<sub>AS</sub></b>	Address setup time		3		4		4		ns
<b>t<sub>WP</sub></b>	Write pulse width		10		12		13		ns
<b>t<sub>WR</sub></b>	Write recovery time		2		3		3		ns
<b>t<sub>DW</sub></b>	Data valid to end of write		10		12		13		ns
<b>t<sub>DH</sub></b>	Data hold time		2		3		3		ns
<b>t<sub>OHZ</sub></b>	Output disable to valid data in	C1 = 5 pF, <i>Notes (5), (6)</i>	10		15		13		ns

**AC Operating Characteristics: EPX880 & EPX8160**

<b>External Timing Parameters</b>			EPX880-10 EPX8160-10 <i>Note (2)</i>		EPX880-12 EPX8160-12 <i>Note (2)</i>		
<b>Combinatorial Mode</b>			Min	Max	Min	Max	Unit
Symbol	Parameter	Conditions	Min	Max	Min	Max	Unit
<b>t<sub>PD</sub></b>	Input or I/O to output valid	C1 = 35 pF		10		12	ns
<b>t<sub>PZX</sub></b>	Input or I/O to output enable	C1 = 35 pF		12		14	ns
<b>t<sub>PXZ</sub></b>	Input or I/O to output disable	C1 = 5 pF		12		14	ns
<b>t<sub>CLR</sub></b>	Array output clear time			15		18	ns
<b>t<sub>COMP</sub></b>	Comparator input or I/O feedback to output valid			10		12	ns

External Timing Parameters			EPX880-10 EPX8160-10 Note (2)		EPX880-12 EPX8160-12 Note (2)		
Register Mode—Synchronous Clock							
Symbol	Parameter	Conditions	Min	Max	Min	Max	Unit
f <sub>MAX</sub>	Maximum frequency	Note (3)	100		83.3		MHz
t <sub>SU</sub>	Input setup time		6.5		8		ns
t <sub>H</sub>	Input hold time		0		0		ns
t <sub>CH</sub>	Clock high time		4.5		5.5		ns
t <sub>CL</sub>	Clock low time		4.5		5.5		ns
t <sub>CP</sub>	Clock period		10		12		ns
t <sub>CO</sub>	Clock-to-output delay	C1 = 35 pF		6		7.5	
t <sub>CNT</sub>	Minimum clock period			12.5		15.5	
f <sub>CNT</sub>	Internal maximum frequency	Note (4)	80		64.5		MHz

External Timing Parameters			EPX880-10 EPX8160-10 Note (2)		EPX880-12 EPX8160-12 Note (2)		
Register Mode—Delayed Synchronous Clock							
Symbol	Parameter	Conditions	Min	Max	Min	Max	Unit
f <sub>MAX</sub>	Maximum frequency	Note (3)	92.9		80		MHz
t <sub>SU</sub>	Input setup time		5		6		ns
t <sub>H</sub>	Input hold time		2		2		ns
t <sub>CH</sub>	Clock high time		4.5		5.5		ns
t <sub>CL</sub>	Clock low time		4.5		5.5		ns
t <sub>CP</sub>	Clock period		10.5		12.5		ns
t <sub>CO</sub>	Clock-to-output delay	C1 = 35 pF		8		9.5	ns
t <sub>CNT</sub>	Minimum clock period			13		15.5	ns
f <sub>CNT</sub>	Internal maximum frequency	Note (4)	76.9		64.5		MHz

External Timing Parameters			EPX880-10 EPX8160-10 Note (2)		EPX880-12 EPX8160-12 Note (2)		
Register Mode—Array Clock							
Symbol	Parameter	Conditions	Min	Max	Min	Max	Unit
f <sub>AMAX</sub>	Maximum frequency	Note (3)	80		66.7		MHz
t <sub>ASU</sub>	Input setup time		2		2.5		ns
t <sub>AH</sub>	Input hold time		5		6		ns
t <sub>ACH</sub>	Clock high time		5		5.5		ns
t <sub>ACL</sub>	Clock low time		5		5.5		ns
t <sub>ACP</sub>	Clock period		12.5		15		ns
t <sub>ACO</sub>	Clock-to-output delay	C1 = 35 pF		12		14.5	ns
t <sub>ACNT</sub>	Minimum clock period			14		17	ns
f <sub>ACNT</sub>	Internal maximum frequency	Note (4)	71.4		58.8		MHz

<b>External Timing Parameters</b>			EPX880-10 EPX8160-10 <i>Note (2)</i>		EPX880-12 EPX8160-12 <i>Note (2)</i>		
<b>SRAM Read</b> <i>Note (1)</i>							
<b>Symbol</b>	<b>Parameter</b>	<b>Conditions</b>	<b>Min</b>	<b>Max</b>	<b>Min</b>	<b>Max</b>	<b>Unit</b>
<b>t<sub>RC</sub></b>	Read cycle time		15		18		ns
<b>t<sub>AA</sub></b>	Address access time			15		18	ns
<b>t<sub>ABE</sub></b>	Block enable access time			15		18	ns
<b>t<sub>OE</sub></b>	Output enable to output valid	<i>Note (5)</i>		12		15	ns
<b>t<sub>OH</sub></b>	Output hold from address change		2		3		ns
<b>t<sub>BLZ</sub></b>	Block enable to output in low impedance	<i>Note (5)</i>	3		4		ns
<b>t<sub>BHZ</sub></b>	Block disable to output in high impedance	C1 = 5 pF, <i>Note (5)</i>		12		15	ns
<b>t<sub>OLZ</sub></b>	Output enable to output in low impedance	<i>Note (5)</i>	3		4		ns

<b>External Timing Parameters</b>			EPX880-10 EPX8160-10 <i>Note (2)</i>		EPX880-12 EPX8160-12 <i>Note (2)</i>		
<b>Register SRAM Read—Synchronous</b> <i>Note (1)</i>							
<b>Symbol</b>	<b>Parameter</b>	<b>Conditions</b>	<b>Min</b>	<b>Max</b>	<b>Min</b>	<b>Max</b>	<b>Unit</b>
<b>t<sub>SU</sub></b>	Input or I/O setup time to clock		11		13		ns
<b>t<sub>H</sub></b>	Input or I/O hold time from clock		0		0		ns
<b>t<sub>CO1</sub></b>	Clock-to-output valid			6		7.5	ns
<b>t<sub>CL</sub></b>	Clock low time		4.5		5.5		ns
<b>t<sub>CH</sub></b>	Clock high time		4.5		5.5		ns
<b>t<sub>CP</sub></b>	Clock period		15		17		ns

<b>External Timing Parameters</b>			EPX880-10 EPX8160-10 <i>Note (2)</i>		EPX880-12 EPX8160-12 <i>Note (2)</i>		
<b>Register SRAM Read—Delayed Synchronous</b> <i>Note (1)</i>							
<b>Symbol</b>	<b>Parameter</b>	<b>Conditions</b>	<b>Min</b>	<b>Max</b>	<b>Min</b>	<b>Max</b>	<b>Unit</b>
<b>t<sub>SU</sub></b>	Input or I/O setup time to clock		10		11		ns
<b>t<sub>H</sub></b>	Input or I/O hold time from clock		2		2		ns
<b>t<sub>CO1</sub></b>	Clock-to-output valid			8		9.5	ns
<b>t<sub>CL</sub></b>	Clock low time		4.5		5.5		ns
<b>t<sub>CH</sub></b>	Clock high time		4.5		5.5		ns
<b>t<sub>CP</sub></b>	Clock period		15.5		17.5		ns

<b>External Timing Parameters</b>			EPX880-10 EPX8160-10 <i>Note (2)</i>		EPX880-12 EPX8160-12 <i>Note (2)</i>		
<b>SRAM Write</b> <i>Note (1)</i>			<b>Min</b>	<b>Max</b>	<b>Min</b>	<b>Max</b>	<b>Unit</b>
<b>Symbol</b>	<b>Parameter</b>	<b>Conditions</b>					
<b>t<sub>WC</sub></b>	Write cycle time		15		18		ns
<b>t<sub>BW</sub></b>	Block enable to end of write		10		12		ns
<b>t<sub>AW</sub></b>	Address valid to end of write		13		15		ns
<b>t<sub>AS</sub></b>	Address set-up time		3		4		ns
<b>t<sub>WP</sub></b>	Write pulse width		10		12		ns
<b>t<sub>WR</sub></b>	Write recovery time		2		3		ns
<b>t<sub>DW</sub></b>	Data valid to end of write		10		12		ns
<b>t<sub>DH</sub></b>	Data hold time		2		3		ns
<b>t<sub>OHZ</sub></b>	Output disable to valid data in	C1 = 5 pF <i>Notes (5), (6)</i>	12		15		ns

**Notes to tables:**

- (1) Operating conditions:  $T_A = 0^\circ\text{C}$  to  $70^\circ\text{C}$ ,  $V_{CC} = 5.0\text{V} \pm 5\%$  for commercial use.  
 $T_A = -40^\circ\text{C}$  to  $85^\circ\text{C}$ ,  $V_{CC} = 5.0\text{V} \pm 10\%$  for industrial use.
- (2) The parameters for the EPX740-12, EPX780-12, EPX880-10, EPX880-12 are preliminary.
- (3) The  $f_{MAX}$  values represent the highest frequency for pipelined data.
- (4) Measured with a 10-bit loadable, enabled, up/down binary counter programmed into each LAB.
- (5) These signals are measured at  $\pm 0.5\text{V}$  from steady-state voltage as driven by specified output load.  $Z \rightarrow H$  and  $Z \rightarrow L$  are measured at 1.5 V on output.
- (6) These specifications do not apply when separate data-in and data-out buses are used.

## Calculating the Supply Current

Supply current ( $I_{CC}$ ) versus frequency ( $f_{MAX}$ ) for FLASHlogic devices is calculated using the following equation:

$$I_{CC} = I_{CC_{OUTPUT}} + I_{CC_{ACTIVE}}$$

The  $I_{CC_{OUTPUT}}$  value, which depends on the device output load characteristics and switching frequency, can be calculated using the guidelines provided in the *Operating Requirements for Altera Devices Data Sheet* in this data book. The  $I_{CC_{ACTIVE}}$  value depends on the switching frequency and the application logic. The following equation shows the formula for calculating  $I_{CC_{ACTIVE}}$ :

$$I_{CC_{ACTIVE}} = (A \times MC) + (C \times MC) \times f_{MAX}$$

The parameters for this equation are:

MC = Number of macrocells used in the design

$f_{MAX}$  = Highest Clock frequency to the device

Table 7 lists the values for the constants A and C.

Device	Constant A	Constant C
EPX740	0.500	0.0250
EPX740Z	0.025	0.0250
EPX780	0.250	0.0188
EPX780Z	0.0125	0.0188
EPX880 (1)	0.0125	0.0188
EPX8160	0.0062	0.0156

**Note:**

(1) This data is preliminary.

The formula for calculating  $I_{CC_{ACTIVE}}$  provides an estimate based on typical conditions using a typical pattern of a 20-bit, loadable, enabled, up/down binary counter with no output load in each pair of LABs. Actual  $I_{CC}$  should be verified during operation since this measurement is sensitive to the actual pattern in the device and the environmental operating conditions.

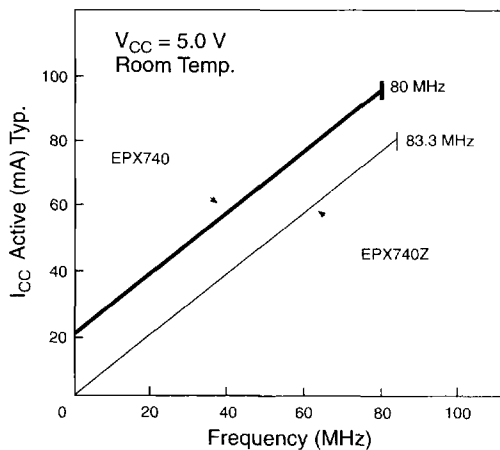

Figure 12 shows the typical supply current versus frequency curves for FLASHlogic devices.

**Figure 12.  $I_{CC}$  versus Frequency for FLASHlogic Devices**

*The output drive characteristics for EPX880 devices are preliminary.*

**EPX740 & EPX740Z**



**EPX780 & EPX780Z**

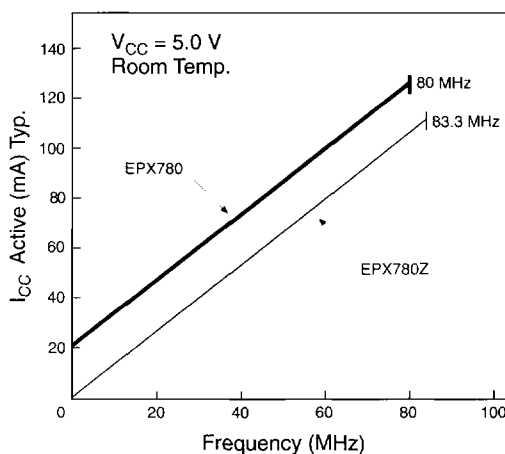

**EPX880**

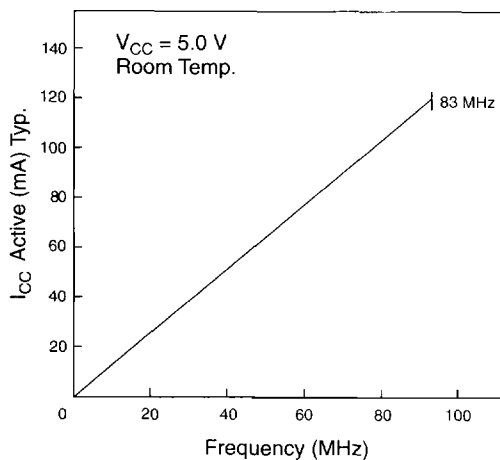

**EPX8160**

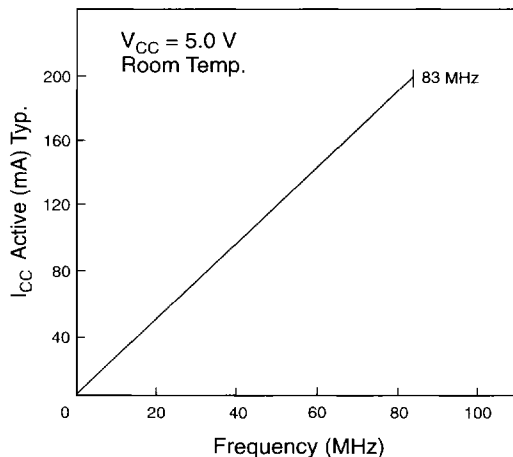

## Power-Up Cycle

Because  $V_{CC}$  rise can vary significantly from one application to another, the power-up cycle time varies. For a monotonic  $V_{CC}$  rise (1 ms/V minimum), the power-up cycle is complete when  $V_{CC}$  reaches its minimum value. The power-up cycle is complete 100  $\mu$ s after  $V_{CC}$  reaches the minimum value.

Internal power-up reset circuits ensure that all flipflops are reset to a logic low after the device has powered up. Also, the JTAG TAP controller is put into the Test-Logic-Reset state. During power-up, EPX8160 I/O pins are held high by an active-weak pull-up resistor; EPX740, EPX780, and EPX880 I/O pins are tri-stated. Upon completion of the power-up cycle, the outputs on an unprogrammed device are placed in a high-impedance state.

## Power-On Reset (POR) Feature

FLASHlogic device configuration data can be reloaded from EPROM or FLASH memory at any time by issuing a JTAG RESET instruction or by holding  $V_{PP}$  at a logic low (0.8 V maximum) for a minimum of 300 ns. By holding  $V_{PP}$  low during power-up, the power-up cycle can be delayed. The power-up cycle is completed within a delay of  $t_{RESET}$  after  $V_{PP}$  reaches 2.0 V (see Table 8). During normal operation,  $V_{PP}$  must be held at a logic high (2.4 V minimum) or tied to the  $V_{PP}$  supply (12.0 V).

During reconfiguration or reprogramming, the JTAG RESET instruction is automatically issued by PENGN or JED2JTAG (PLDshell Plus software utilities). It is not necessary to pull  $V_{PP}$  low after a reconfiguration or reprogram cycle.

**Table 8. Reset Characteristics**

Symbol	Parameter	Value	Conditions
$t_{RESET}$	JTAG reset time	150 $\mu$ s maximum	Software Control $V_{PP} \geq 2.0$ V

Go to *Application Note 45 (Configuring FLASHlogic Devices)*, for more information on configuring or programming FLASHlogic devices using the JTAG interface.

## Pin Descriptions

Table 9 lists the dedicated pin names and descriptions.

<b>Pin Name</b>	<b>Description</b>
VCC, <i>Note (1)</i>	Supply voltage. Must be connected to 5.0 V.
GND	Ground connection.
VPP, <i>Note (1)</i>	Programming voltage. When programming EPX740 and EPX780 devices, 12.75 V must be supplied to this pin. When programming EPX880 and EPX8160 devices, 12.0 V must be supplied to this pin. When the EPX740, EPX780, and EPX880 devices are not in programming mode, this pin can be connected to VCC or VPP, or left floating. When the EPX8160 devices are not in programming mode, this pin can be connected to VCC or VPP. The EPX8160 device requires that VPP be held low (0.8 V maximum) for a minimum of 300 ns to reset the device.
INN	Input-only pins. These pins are not available in all packages. Unused inputs should be connected to VCC or GND.
TDI	Test data input. This pin is the boundary-scan serial data input to FLASHlogic devices. JTAG instructions and data are shifted into FLASHlogic devices on the TDI input pin on the rising edge of TCK. TDI can be left floating if unused.
TDO	Test data output. This is the boundary-scan serial data output from FLASHlogic devices. JTAG instructions and data are shifted out of FLASHlogic devices on the TDO output pin on the falling edge of TCK.
TCK	Test Clock input. This input provides the boundary-scan Clock for FLASHlogic devices. TCK Clocks shift information and data into and out of the FLASHlogic devices during boundary-scan or programming modes. The maximum operating frequency of the boundary-scan test Clock is 8 MHz. TCK can be left floating if unused.
TMS	Test control input. This input provides the boundary-scan test mode select for FLASHlogic devices. TMS can be left floating if unused.

**Note:**

- (1) Proper power decoupling is required on all power pins. A 0.1- $\mu$ F decoupling capacitor is recommended between each power pin and ground.

Table 10 lists the user-defined pin names and descriptions.

<b>Table 10. User-Defined Pins</b>	
<b>Pin Name</b>	<b>Description</b>
VCC0 $n$ , <i>Note (1)</i>	Supply voltage for the outputs of the LABs. Connecting these pins to 5.0 V causes the LAB to output 5.0-V signals. Connecting these pins to 3.3 V causes the LAB to output 3.3-V signals. These pins must always be connected to the desired output drive voltage.
CLK $n$	Global Clock signals.
I/O $n$	Pins configurable as inputs or outputs. Unused I/O pins should be connected as shown in the Report File. The reserved pins must be left unconnected.

**Note:**

- (1) Proper power decoupling is required on all power pins. A 0.1- $\mu$ F decoupling capacitor is recommended between each power pin and ground.

## Device Pin-Outs

Tables 11 through 16 show the pin-outs for FLASHlogic device packages.

<b>Table 11. EPX740 Dedicated Pin-Outs</b>		
<b>Dedicated Pin</b>	<b>44-Pin PLCC</b>	<b>68-Pin PLCC</b>
CLK1	13	19
CLK2	35	53
TDI	22	33
TDO	21	32
TMS	44	67
TCK	43	66
VPP	14	20
VCC00	12	18
VCC01	12	17
VCC02	34	51
VCC03	34	52
VCC	23	35
GND	1, 15, 36, 37	1, 21, 34, 54, 55, 68
Dedicated Inputs	–	16, 15, 4, 3, 2, 50, 49, 38, 37, 36

LAB	MC	44-Pin J-Lead	68-Pin J-Lead	LAB	MC	44-Pin J-Lead	68-Pin J-Lead
0	0	16	22	1	10	11	14
0	1	–	23	1	11	10	13
0	2	–	24	1	12	9	12
0	3	17	25	1	13	8	11
0	4	–	26	1	14	7	10
0	5	18	27	1	15	6	9
0	6	–	28	1	16	5	8
0	7	19	29	1	17	4	7
0	8	–	30	1	18	3	6
0	9	20	31	1	19	2	5
2	20	33	48	3	30	38	56
2	21	32	47	3	31	–	57
2	22	31	46	3	32	–	58
2	23	30	45	3	33	39	59
2	24	29	44	3	34	–	60
2	25	28	43	3	35	40	61
2	26	27	42	3	36	–	62
2	27	26	41	3	37	41	63
2	28	25	40	3	38	–	64
2	29	24	39	3	39	42	65

**Note:**

(1) A dash (–) indicates that the macrocell is buried.

<b>Table 13. EPX780 &amp; EPX880 Dedicated Pin-Outs</b> <i>Note (1), (2)</i>		
<b>Dedicated Pin</b>	<b>84-Pin PLCC</b>	<b>132-Pin PQFP</b>
CLK1	3	118
CLK2	45	52
TDI	11	132
TDO	10	131
TMS	52	65
TCK	53	66
VPP	4	119
VCC00	25	117
VCC01	2	116
VCC02	24	19
VCC03	67	86
VCC04	25	20
VCC05	66	85
VCC06	44	50
VCC07	67	51
VCC	26, 68	21, 87
GND	17, 23, 29, 38, 46, 59, 65, 71, 80	11, 17, 18, 27, 44, 53, 59, 77, 83, 84, 93, 110, 125
Dedicated Inputs	—	1, 2, 3, 4, 5, 33, 34, 35, 36, 37, 38, 67, 68, 69, 70, 71, 99, 100, 101, 102, 103, 104,

**Notes:**

- (1) The pin-outs for EPX880 devices are preliminary.
- (2) Contact Altera Marketing for the EPX880 160-pin package pin-outs.

**Table 14. EPX780 & EPX880 I/O Pin-Outs (Part 1 of 2)** Notes (1), (2), (3)

LAB	MC	84-Pin J-Lead	132-Pin QFP	LAB	MC	84-Pin J-Lead	132-Pin QFP
0	0	5	120	1	10	1	115
0	1	–	121	1	11	84	114
0	2	–	122	1	12	83	113
0	3	6	123	1	13	82	112
0	4	–	124	1	14	81	111
0	5	7	126	1	15	79	109
0	6	–	127	1	16	78	108
0	7	8	128	1	17	77	107
0	8	–	129	1	18	76	106
0	9	9	130	1	19	75	105
2	20	22	16	3	30	69	88
2	21	21	15	3	31	–	89
2	22	20	14	3	32	–	90
2	23	19	13	3	33	70	91
2	24	18	12	3	34	–	92
2	25	16	10	3	35	72	94
2	26	15	9	3	36	–	95
2	27	14	8	3	37	73	96
2	28	13	7	3	38	–	97
2	29	12	6	3	39	74	98

**Table 14. EPX780 & EPX880 I/O Pin-Outs (Part 2 of 2)** Notes (1), (2), (3)

LAB	MC	84-Pin J-Lead	132-Pin QFP	LAB	MC	84-Pin J-Lead	132-Pin QFP
4	40	27	22	5	50	64	82
4	41	–	23	5	51	63	81
4	42	–	24	5	52	62	80
4	43	28	25	5	53	61	79
4	44	–	26	5	54	60	78
4	45	30	28	5	55	58	76
4	46	–	29	5	56	57	75
4	47	31	30	5	57	56	74
4	48	–	31	5	58	55	73
4	49	32	32	5	59	54	72
6	60	43	49	7	70	47	54
6	61	42	48	7	71	–	55
6	62	41	47	7	72	–	56
6	63	40	46	7	73	48	57
6	64	39	45	7	74	–	58
6	65	37	43	7	75	49	60
6	66	36	42	7	76	–	61
6	67	35	41	7	77	50	62
6	68	34	40	7	78	–	63
6	69	33	39	7	79	51	64

**Notes:**

- (1) The pin-outs for EPX880 devices are preliminary.
- (2) A dash (-) indicates that the macrocell is buried.
- (3) Contact Altera Marketing for the EPX880 160-pin package pin-outs.



<b>Dedicated Pin</b>	<b>208-Pin PQFP</b>
CLK1	184
CLK2	181
CLK3	77
CLK4	80
TDI	1
TDO	208
TMS	105
TCK	104
VPP0	182
VPP1	79
VCC00/VCC02	204
VCC01/VCC03	161
VCC04/VCC06	13
VCC05/VCC07	144
VCC08/VCC010	57
VCC09/VCC011	100
VCC012/VCC014	40
VCC013/VCC015	117
VCC	14, 39, 118, 143
GND	7, 15, 21, 32, 38, 46, 67, 78, 90, 111, 119, 125, 136, 142, 150, 171, 183, 194
Dedicated Inputs	52, 53, 54, 55, 56, 59, 61, 63, 65, 69, 71, 73, 75, 82, 84, 86, 88, 92, 94, 96, 98, 101, 102, 103, 156, 157, 158, 159, 160, 163, 165, 167, 169, 173, 175, 177, 179, 186, 188, 190, 192, 196, 198, 200, 202, 205, 206, 207

<i>Table 16. EPX8160 I/O Pin-Outs (Part 1 of 3) Note (1)</i>					
LAB	MC	208-Pin PQFP	LAB	MC	208-Pin PQFP
0	0	185	1	10	180
0	1	187	1	11	178
0	2	189	1	12	176
0	3	191	1	13	174
0	4	193	1	14	172
0	5	195	1	15	170
0	6	197	1	16	168
0	7	199	1	17	166
0	8	201	1	18	164
0	9	203	1	19	162
2	20	6	3	30	151
2	21	–	3	31	–
2	22	–	3	32	–
2	23	5	3	33	152
2	24	–	3	34	–
2	25	4	3	35	153
2	26	–	3	36	–
2	27	3	3	37	154
2	28	–	3	38	–
2	29	2	3	39	155
4	40	8	5	50	149
4	41	9	5	51	148
4	42	10	5	52	147
4	43	11	5	53	146
4	44	12	5	54	145
4	45	16	5	55	141
4	46	17	5	56	140
4	47	18	5	57	139
4	48	19	5	58	138
4	49	20	5	59	137

Table 16. EPX8160 I/O Pin-Outs (Part 2 of 3) Note (1)

LAB	MC	208-Pin PQFP	LAB	MC	208-Pin PQFP
6	60	26	7	70	131
6	61	–	7	71	–
6	62	–	7	72	–
6	63	25	7	73	132
6	64	–	7	74	–
6	65	24	7	75	133
6	66	–	7	76	–
6	67	23	7	77	134
6	68	–	7	78	–
6	69	22	7	79	135
8	80	76	9	90	81
8	81	74	9	91	83
8	82	72	9	92	85
8	83	70	9	93	87
8	84	68	9	94	89
8	85	66	9	95	91
8	86	64	9	96	93
8	87	62	9	97	95
8	88	60	9	98	97
8	89	58	9	99	99
10	100	47	11	110	110
10	101	–	11	111	–
10	102	–	11	112	–
10	103	48	11	113	109
10	104	–	11	114	–
10	105	49	11	115	108
10	106	–	11	116	–
10	107	50	11	117	107
10	108	–	11	118	–
10	109	51	11	119	106

<b>Table 16. EPX8160 I/O Pin-Outs (Part 3 of 3) Note (1)</b>					
<b>LAB</b>	<b>MC</b>	<b>208-Pin PQFP</b>	<b>LAB</b>	<b>MC</b>	<b>208-Pin PQFP</b>
12	120	45	13	130	112
12	121	44	13	131	113
12	122	43	13	132	114
12	123	42	13	133	115
12	124	41	13	134	116
12	125	37	13	135	120
12	126	36	13	136	121
12	127	35	13	137	122
12	128	34	13	138	123
12	129	33	13	139	124
14	140	27	15	150	130
14	141	–	15	151	–
14	142	–	15	152	–
14	143	28	15	153	129
14	144	–	15	154	–
14	145	29	15	155	128
14	146	–	15	156	–
14	147	30	15	157	127
14	148	–	15	158	–
14	149	31	15	159	126

**Note:**

(1) A dash (–) indicates that the macrocell is buried.

# Package Diagrams

Figures 13 through 16 show the package pin-out diagrams for FLASHlogic devices.

**Figure 13. EPX740 Package Pin-Out Diagrams**

Package outlines are not drawn to scale. See Tables 11 and 12 for pin-out information.

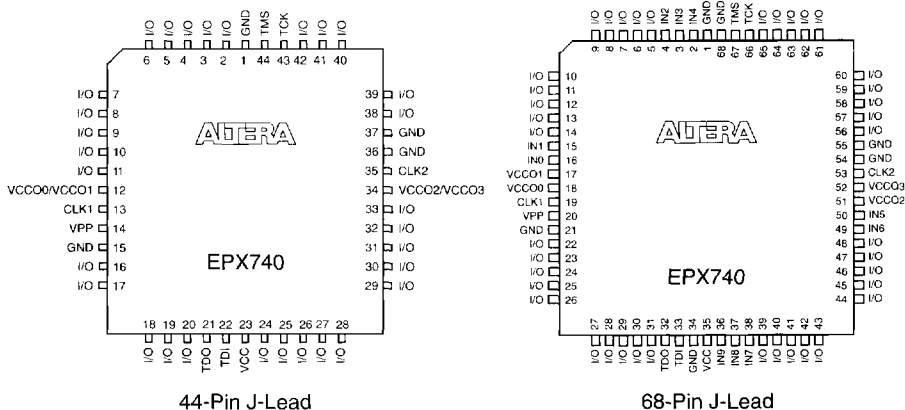

**Figure 14. EPX780 Package Pin-Out Diagrams**

Package outlines are not drawn to scale. See Tables 13 and 14 for pin-out information.

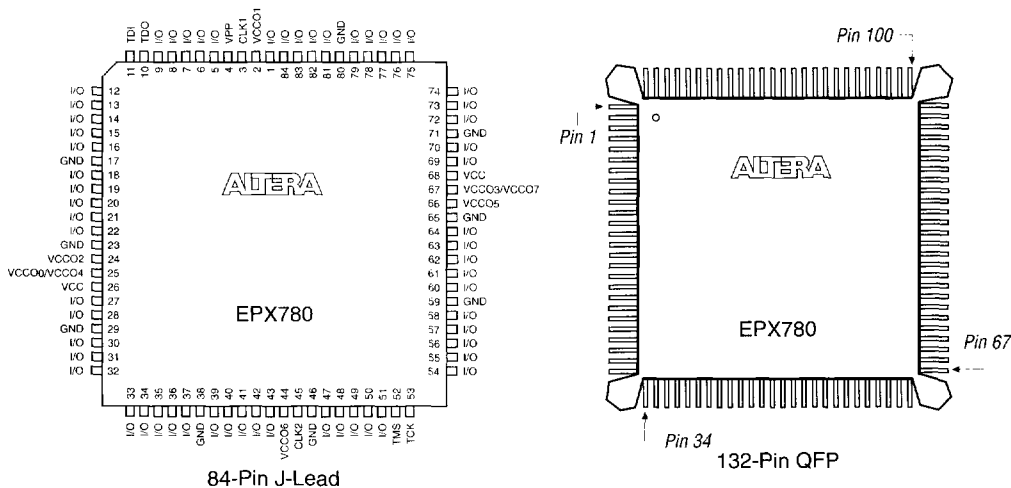

**Figure 15. EPX880 Package Pin-Out Diagram**

Package outline not drawn to scale. See Tables 13 and 14 for pin-out information.

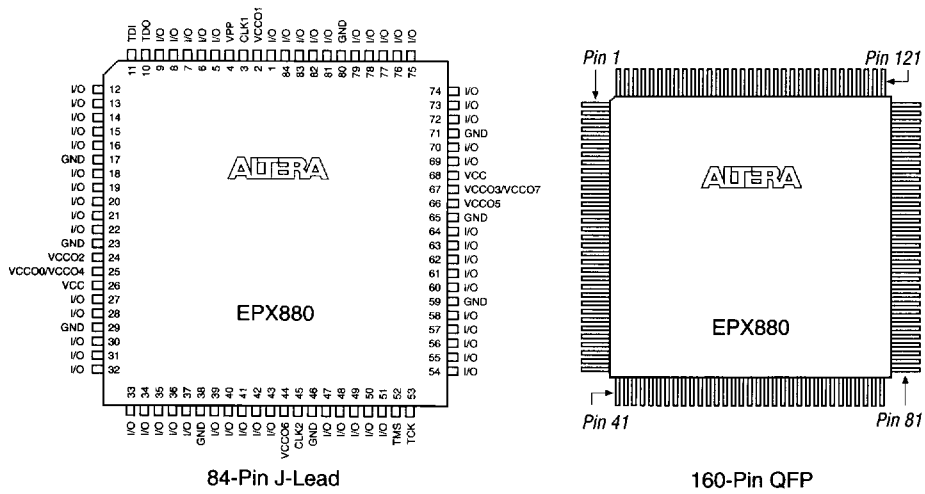

**Figure 16. EPX8160 Package Pin-Out Diagram**

Package outline not drawn to scale. See Tables 15 and 16 for pin-out information.

