



1-Line To 10-Line Clock Driver With 3-State Outputs

Features

- Low Output Skew, Low Pulse Skew for Clock-Distribution and Clock-Generation Applications.
- Operates at 3.3V Supply Voltage.
- LVTTTL-Compatible Inputs and Outputs.
- Supports Mixed-Mode Signal Operation. (5V Input and Output Voltages With 3.3V Supply Voltage).
- Distributes One Clock Input to Ten Outputs.
- Outputs have Internal Series Damping Resistor to Reduce Transmission Line Effects.
- Distributed V<sub>CC</sub> and Ground Pins Reduce Switching Noise.
- Package Options Include Plastic Small-Outline and Shrink Small-Outline Packages.

Product Description

The ASM2P2351AH is a high-performance clock-driver circuit that distributes one input (A) to ten outputs (Y) with minimum skew for clock distribution. The output-enable ( $\overline{OE}$ ) input disables the outputs to a high-impedance state. Each output has an internal series damping resistor to improve signal integrity at the load. The ASM2P2351AH operates at nominal 3.3V Supply Voltage.

The propagation delays are adjusted at the factory using the P0 and P1 pins. The factory adjustments ensure that the part-to-part skew is minimized and is kept within a specified window. Pins P0 and P1 are not intended for customer use and should be connected to GND.

The ASM2P2351AH is characterized for operation from 0°C to 70°C.

Logic Diagram (Positive Logic)

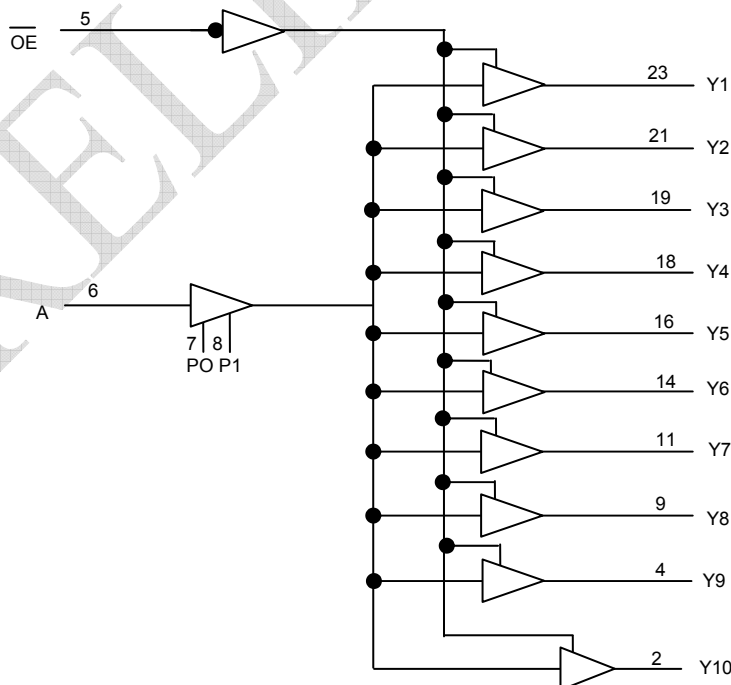



## rev 0.2

## Pin Configuration

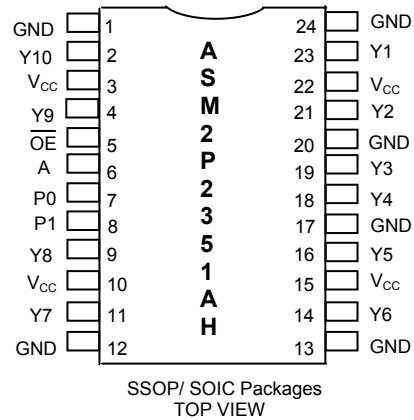

## Pin Description

Pin #	Pin Name	Typ	Description
1	GND	P	Ground Pin
2	Y10	O	Output 10
3	V <sub>CC</sub>	P	Power Supply Pin
4	Y9	O	Output 9
5	$\overline{OE}$	I	Output Enable Pin. When this pin is low, the outputs Y[1:10] are enabled and when this pin is high, the outputs Y[1:10] are disabled.
6	A	I	Input Clock
7	P0	-	No Connect
8	P1	-	No Connect
9	Y8	O	Output 8
10	V <sub>CC</sub>	P	Power Supply
11	Y7	O	Output 7
12	GND	P	Ground Pin
13	GND	P	Ground Pin
14	Y6	O	Output 6
15	V <sub>CC</sub>	P	Power Supply
16	Y5	O	Output 5
17	GND	P	Ground Pin
18	Y4	O	Output 4
19	Y3	O	Output 3
20	GND	P	Ground Pin
21	Y2	O	Output 2
22	V <sub>CC</sub>	P	Power Supply
23	Y1	O	Output 1
24	GND	P	Ground Pin



rev 0.2

## Function Table

Inputs		Outputs
A	$\overline{\text{OE}}$	In
L	H	Z
H	H	Z
L	L	L
H	L	H

## Absolute Maximum Ratings

Symbol	Parameter	Rating	Unit
$V_{CC}$	Voltage on Supply pin with respect to Ground	-0.5 to +4.6	V
$V_{IN}$	Voltage on any pin with respect to Ground	-0.5 to +7.0	V
$t_{STG}$	Storage temperature	-65 to +125	°C
$t_A$	Operating temperature	0 to 70	°C
$t_s$	Max. Soldering Temperature (10 sec)	260	°C
$t_J$	Junction Temperature	150	°C
$t_{DV}$	Static Discharge Voltage (As per JEDEC STD22- A114-B)	2	KV

Note: These are stress ratings only and are not implied for functional use. Exposure to absolute maximum ratings for prolonged periods of time may affect device reliability.

## Recommended operating conditions (see Note 3)

Symbol	Parameter	Min	Max	Unit
$V_{CC}$	Supply voltage	3	3.6	V
$V_{IH}$	High-level input voltage	2		V
$V_{IL}$	Low-level input voltage		0.8	V
$V_I$	Input voltage	0	5.5	V
$I_{OH}$	High-level output current		-12	mA
$I_{OL}$	Low-level output current		12	mA
$f_{clock}$	Input clock frequency		100	MHz
$T_A$	Operating free air temperature	0	70	°C

NOTE 3: Unused pins (input or I/O) must be held high or low.



rev 0.2

Electrical characteristics over recommended operating free-air temperature range (unless otherwise noted)

Parameter	Test Conditions		Min	Typ	Max	Unit
$V_{IK}$	$V_{CC} = 3\text{ V}$ ,	$I_I = -18\text{ mA}$			-1.2	V
$V_{OH}$	$V_{CC} = 3\text{ V}$ ,	$I_{OH} = -12\text{ mA}$	2			V
$V_{OL}$	$V_{CC} = 3\text{ V}$ ,	$I_{OL} = 12\text{ mA}$			0.8	V
$I_I$	$V_{CC} = 3.6\text{ V}$ ,	$V_I = V_{CC}$ or GND			$\pm 1$	mA
$I_O^1$	$V_{CC} = 3.6\text{ V}$ ,	$V_O = 2.5\text{ V}$	-7		-70	mA
$I_{OZ}$	$V_{CC} = 3.6\text{ V}$ ,	$V_{CC} = 3\text{ V}$			$\pm 10$	mA
$I_{CC}$	$V_{CC} = 3.6\text{ V}$ , $I_O = 0$ ,	$V_I = V_{CC}$ or GND	Outputs high		0.3	mA
			Outputs low		15	
			Outputs disabled		0.3	
$C_i$	$V_I = V_{CC}$ or GND,	$V_{CC} = 3.3\text{ V}$ ,	$f = 10\text{ MHz}$		4	pF
$C_o$	$V_O = V_{CC}$ or GND,	$V_{CC} = 3.3\text{ V}$ ,	$f = 10\text{ MHz}$		6	pF

Note: 1 Not more than one output should be tested at a time, and the duration of the test should not exceed one second.

Switching Characteristics,  $C_L = 50\text{ pF}$  (see Figures 1 and 2)

Parameter	From (Input)	To (Output)	ASM2P2351A			ASM2P2351AH		Unit
			$V_{CC} = 3.3\text{ V}$ , $T_A = 25^\circ\text{C}$			$V_{CC} = 3\text{ V to } 3.6\text{ V}$ , $T_A = 0^\circ\text{C to } 70^\circ\text{C}$		
			Min	Typ	Max	Min	Max	
$t_{PLH}$	A	Y	3.8	4.3	4.8			nS
$t_{PHL}$			3.6	4.1	4.6			
$t_{PZH}$	$\overline{OE}$	Y	2.4	4.9	6.0	1.8	6.9	nS
$t_{PZL}$			2.4	4.3	6.0	1.8	6.9	
$t_{PHZ}$	$\overline{OE}$	Y	2.2	4.4	6.3	2.1	7.1	nS
$t_{PLZ}$			2.2	4.6	6.3	2.1	7.3	
$t_{sk(o)}$	A	Y		0.3	0.5		0.5	nS
$t_{sk(p)}$	A	Y		0.2	0.8		0.8	nS
$t_{sk(pr)}$	A	Y			1		1	nS
$t_r$	A	Y					2.5	nS
$t_f$	A	Y					2.5	nS



## rev 0.2

**Switching Characteristics temperature and  $V_{CC}$  coefficients over recommended operating free-air temperature and  $V_{CC}$  range** (see Note 3)

Parameter		From (Input)	To (Output)	Min	Max	Unit
$t_{PLH}(T)$	Average temperature coefficient of low to high propagation delay	A	Y		$85^1$	pS/10°C
$t_{PHL}(T)$	Average temperature coefficient of high to low propagation delay	A	Y		$50^1$	pS/10°C
$t_{PLH}(V_{CC})$	Average $V_{CC}$ coefficient of low to high propagation delay	A	Y		$-145^2$	pS/ 100 mV
$t_{PHL}(V_{CC})$	Average $V_{CC}$ coefficient of high to low propagation delay	A	Y		$-100^2$	pS/ 100 mV

Note: 1  $t_{PLH}(T)$  and  $t_{PHL}(T)$  are virtually independent of  $V_{CC}$ .

2  $t_{PLH}(V_{CC})$  and  $t_{PHL}(V_{CC})$  are virtually independent of temperature.

3 This data was extracted from characterization material and are not tested at the factory.

PRELIMINARY



rev 0.2

Parameter Measurement Information

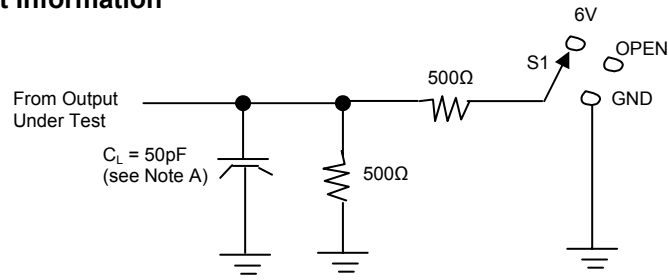

LOAD CIRCUIT

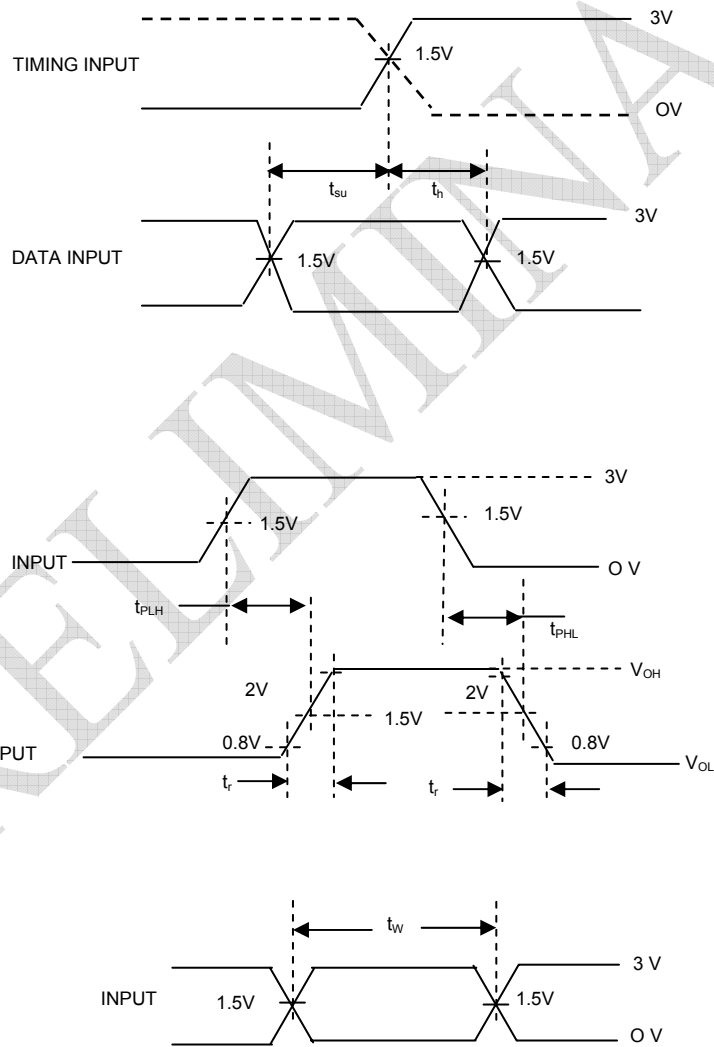

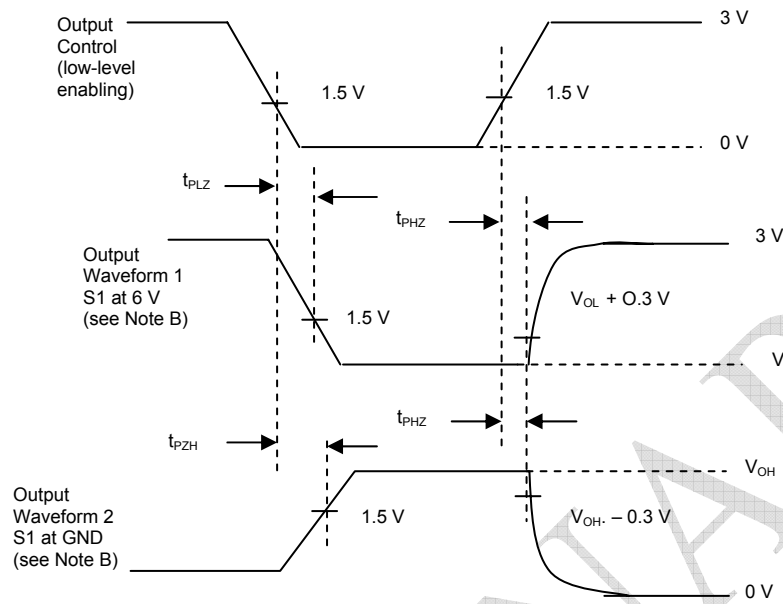

Figure 1. Load Circuit and Voltage Waveforms

NOTES: A. CL includes probe and jig capacitance.

B. Waveform 1 is for an output with internal conditions such that the output is low except when disabled by the output control.

Waveform 2 is for an output with internal conditions such that the output is high except when disabled by the output control.

C. All input pulses are supplied by generators having the following characteristics: PRR 3 10 MHz,  $Z_O = 50\Omega$ ,  $t_r$  3 2.5 nS,  $t_f$  3 2.5 nS.

D. The outputs are measured one at a time with one transition per measurement.



rev 0.2

Parameter Measurement Information

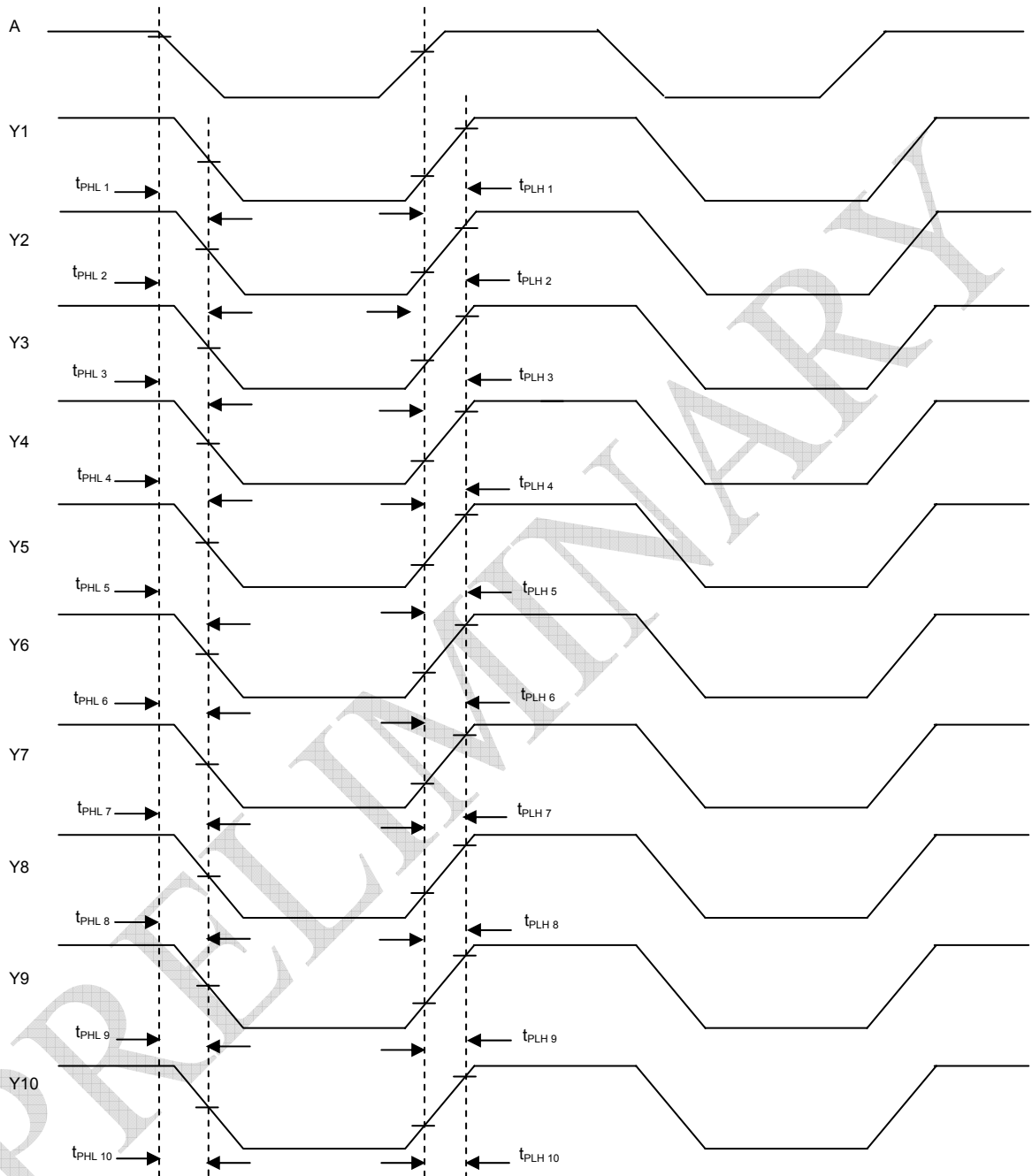

Figure 2. Waveforms for Calculation of  $t_{sk(o)}$ ,  $t_{sk(p)}$ ,  $t_{sk(pr)}$

NOTES: A. Output skew,  $t_{sk(o)}$ , is calculated as the greater of:

- The difference between the fastest and slowest of  $t_{PLHn}$  ( $n = 1, 2, 3, 4, 5, 6, 7, 8, 9, 10$ )
- The difference between the fastest and slowest of  $t_{PHLn}$  ( $n = 1, 2, 3, 4, 5, 6, 7, 8, 9, 10$ )

B. Pulse skew,  $t_{sk(p)}$ , is calculated as the greater of  $|t_{PLHn} - t_{PHLn}|$  ( $n = 1, 2, 3, 4, 5, 6, 7, 8, 9, 10$ ).

C. Process skew,  $t_{sk(pr)}$ , is calculated as the greater of:

- The difference between the fastest and slowest of  $t_{PLHn}$  ( $n = 1, 2, 3, 4, 5, 6, 7, 8, 9, 10$ ) across multiple devices under identical operating conditions
- The difference between the fastest and slowest of  $t_{PHLn}$  ( $n = 1, 2, 3, 4, 5, 6, 7, 8, 9, 10$ ) across multiple devices under identical operating conditions





rev 0.2

Package Information

24L SSOP Package (209 mil)

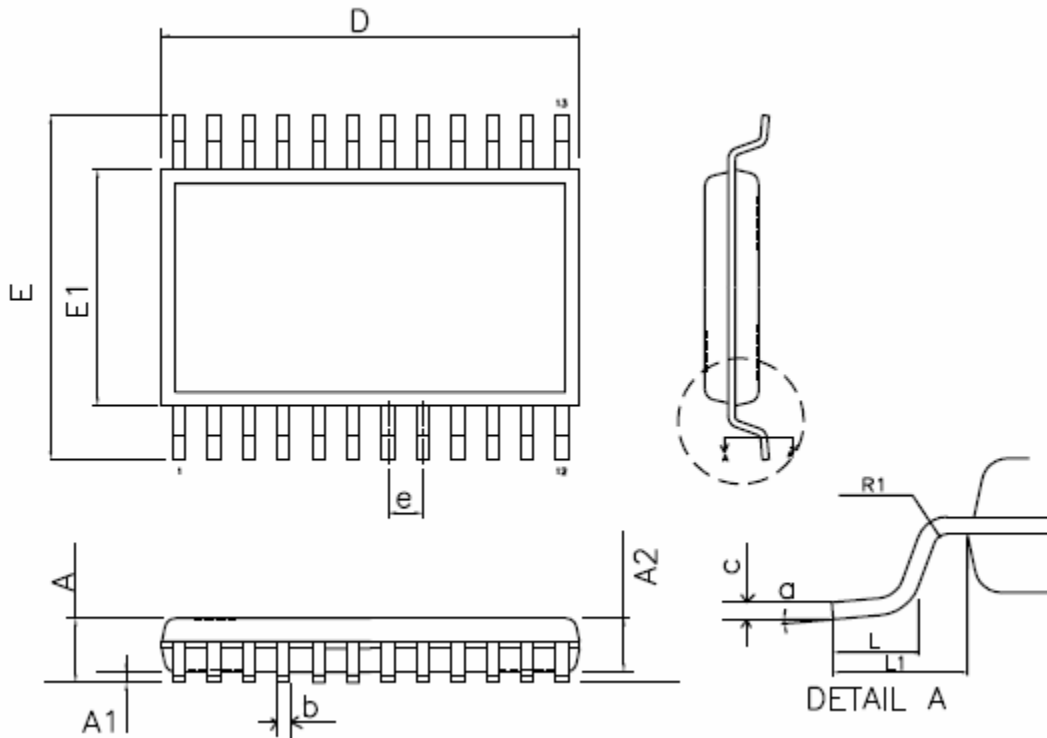

Symbol	Dimensions			
	Inches		Millimeters	
	Min	Max	Min	Max
A	....	0.079	...	2.0
A1	0.002	...	0.05	...
A2	0.065	0.073	1.65	1.85
D	0.315	0.331	8.00	8.40
L	0.021	0.037	0.55	0.95
E	0.295	0.319	7.50	8.10
E1	0.197	0.220	5.00	5.60
R1	0.004	....	0.09	.....
b	0.009	0.015	0.22	0.38
c	0.004	0.010	0.09	0.25
L1	0.050REF		1.25 REF	
e	0.026 BSC		0.65 BSC	
a	0°	8°	0°	8°



24L SOIC Package (300 mil)

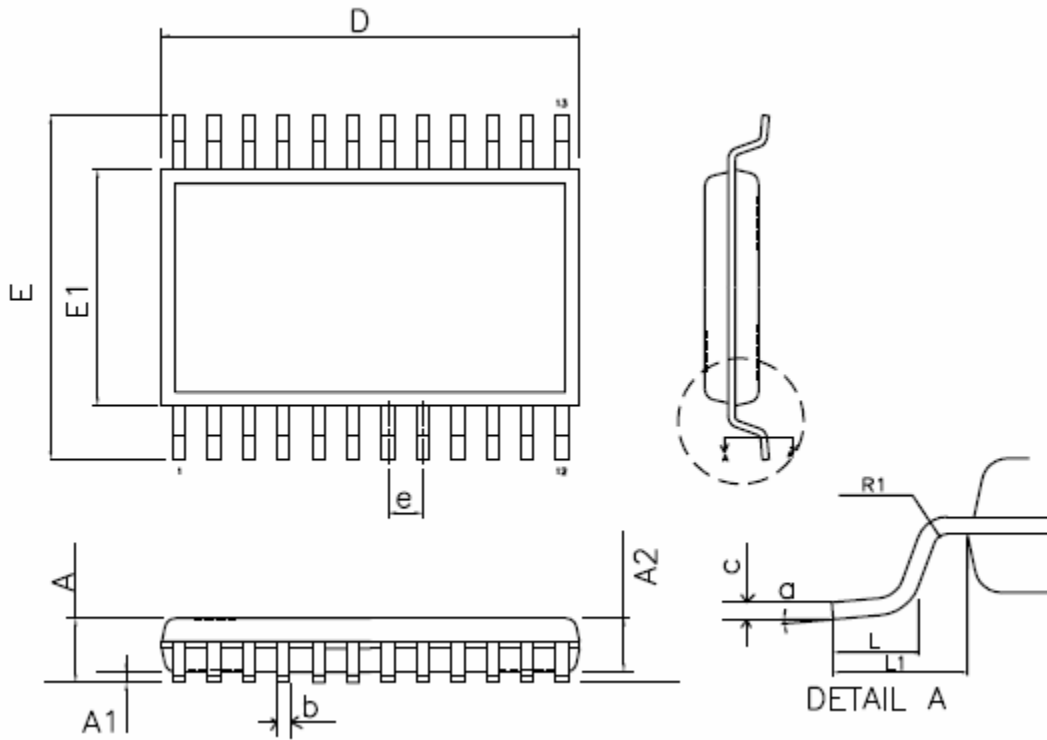

Symbol	Dimensions			
	Inches		Millimeters	
	Min	Max	Min	Max
A	0.093	0.104	2.35	2.65
A1	0.004	0.012	0.10	0.30
A2	0.088	0.094	2.25	2.40
D	0.598	0.614	15.20	15.60
L	0.016	0.050	0.40	1.27
E1	0.291	0.299	7.40	7.60
R1	0.003	.....	0.08	.....
b	0.013	0.022	0.33	0.56
c	0.009	0.015	0.23	0.38
E	0.394	0.419	10.00	10.65
e	0.050 BSC		1.27 BSC	
a	0°	8°	0°	8°



rev 0.2

## Ordering Information

Part Number	Marking	Package Type	Temperature
ASM2P2351AHF-24AR	2P2351AHF	24-Pin SSOP, TAPE & REEL, Pb Free	Commercial
ASM2P2351AHF-24AT	2P2351AHF	24-Pin SSOP, TUBE, Pb Free	Commercial
ASM2P2351AHF -24SR	2P2351AHF	24-Pin SOIC, TAPE & REEL, Pb Free	Commercial
ASM2P2351AHF-24ST	2P2351AHF	24-Pin SOIC, TUBE, Pb Free	Commercial
ASM2P2351AF-24AR	2P2351AF	24-Pin SSOP, TAPE & REEL, Pb Free	Commercial
ASM2P2351AF-24AT	2P2351AF	24-Pin SSOP, TUBE, Pb Free	Commercial
ASM2P2351AF -24SR	2P2351AF	24-Pin SOIC, TAPE & REEL, Pb Free	Commercial
ASM2P2351AF-24ST	2P2351AF	24-Pin SOIC, TUBE, Pb Free	Commercial
ASM2P2351AHG-24AR	2P2351AHG	24-Pin SSOP, TAPE & REEL, Green	Commercial
ASM2P2351AHG-24AT	2P2351AHG	24-Pin SSOP, TUBE, Green	Commercial
ASM2P2351AHG -24SR	2P2351AHG	24-Pin SOIC, TAPE & REEL, Green	Commercial
ASM2P2351AHG-24ST	2P2351AHG	24-Pin SOIC, TUBE, Green	Commercial
ASM2P2351AG-24AR	2P2351AG	24-Pin SSOP, TAPE & REEL, Green	Commercial
ASM2P2351AG-24AT	2P2351AG	24-Pin SSOP, TUBE, Green	Commercial
ASM2P2351AG -24SR	2P2351AG	24-Pin SOIC, TAPE & REEL, Green	Commercial
ASM2P2351AG-24ST	2P2351AG	24-Pin SOIC, TUBE, Green	Commercial
ASM2P2351AH-24AR	2P2351AH	24-Pin SSOP, TAPE & REEL	Commercial
ASM2P2351AH-24AT	2P2351AH	24-Pin SSOP, TUBE	Commercial
ASM2P2351AH -24SR	2P2351AH	24-Pin SOIC, TAPE & REEL	Commercial
ASM2P2351AH-24ST	2P2351AH	24-Pin SOIC, TUBE	Commercial
ASM2P2351A-24AR	2P2351A	24-Pin SSOP, TAPE & REEL	Commercial
ASM2P2351A-24AT	2P2351A	24-Pin SSOP, TUBE	Commercial
ASM2P2351A -24SR	2P2351A	24-Pin SOIC, TAPE & REEL	Commercial
ASM2P2351A-24ST	2P2351A	24-Pin SOIC, TUBE	Commercial



rev 0.2

Device Ordering Information

A S M 2 P 2 3 5 1 A H F - 2 4 A R

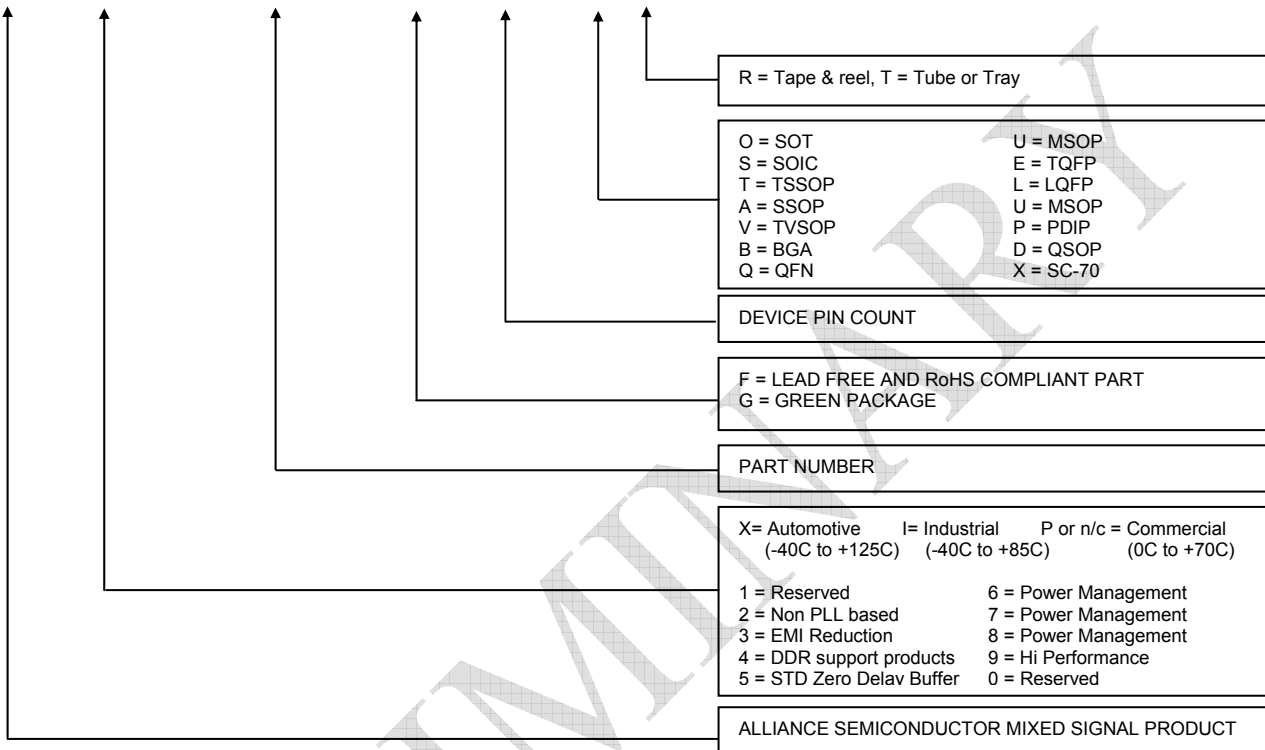

Licensed under US patent Nos 5,488,627 and 5,631,920.



Alliance Semiconductor Corporation  
2575 Augustine Drive,  
Santa Clara, CA 95054  
Tel# 408-855-4900  
Fax: 408-855-4999  
www.alsc.com

Copyright © Alliance Semiconductor  
All Rights Reserved  
Advance Information  
Part Number: ASM2P2351AH  
Document Version: v0.2

Note: This product utilizes US Patent # 6,646,463 Impedance Emulator Patent issued to Alliance Semiconductor, dated 11-11-2003

© Copyright 2003 Alliance Semiconductor Corporation. All rights reserved. Our three-point logo, our name and Intelliwatt are trademarks or registered trademarks of Alliance. All other brand and product names may be the trademarks of their respective companies. Alliance reserves the right to make changes to this document and its products at any time without notice. Alliance assumes no responsibility for any errors that may appear in this document. The data contained herein represents Alliance's best data and/or estimates at the time of issuance. Alliance reserves the right to change or correct this data at any time, without notice. If the product described herein is under development, significant changes to these specifications are possible. The information in this product data sheet is intended to be general descriptive information for potential customers and users, and is not intended to operate as, or provide, any guarantee or warranty to any user or customer. Alliance does not assume any responsibility or liability arising out of the application or use of any product described herein, and disclaims any express or implied warranties related to the sale and/or use of Alliance products including liability or warranties related to fitness for a particular purpose, merchantability, or infringement of any intellectual property rights, except as express agreed to in Alliance's Terms and Conditions of Sale (which are available from Alliance). All sales of Alliance products are made exclusively according to Alliance's Terms and Conditions of Sale. The purchase of products from Alliance does not convey a license under any patent rights, copyrights; mask works rights, trademarks, or any other intellectual property rights of Alliance or third parties. Alliance does not authorize its products for use as critical components in life-supporting systems where a malfunction or failure may reasonably be expected to result in significant injury to the user, and the inclusion of Alliance products in such life-supporting systems implies that the manufacturer assumes all risk of such use and agrees to indemnify Alliance against all claims arising from such use.