

EPS13D2C1HC-45.000M

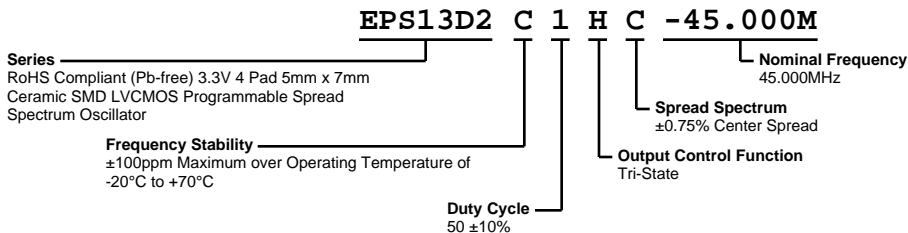

ELECTRICAL SPECIFICATIONS

| | |
|---------------------------------------|--|
| Nominal Frequency | 45.000MHz |
| Frequency Stability | ±100ppm Maximum over Operating Temperature of -20°C to +70°C (Inclusive of all conditions: Frequency Stability over the Operating Temperature Range, Supply Voltage Change, Output Load Change, First Year Aging at 25°C, Shock, and Vibration.) |
| Aging at 25°C | ±5ppm First Year Maximum |
| Supply Voltage | 3.3Vdc ±0.3Vdc |
| Maximum Supply Voltage | -0.5Vdc to +7.0Vdc |
| Input Current | 30mA Maximum (Unloaded; Vdd=3.3Vdc) |
| Output Voltage Logic High (Voh) | Vdd-0.4Vdc Minimum (IOH=-8mA) |
| Output Voltage Logic Low (Vol) | 0.4Vdc Maximum (IOL=+8mA) |
| Rise/Fall Time | 2.7nSec Maximum (Measured at 20% to 80% of Waveform) |
| Duty Cycle | 50 ±10% (Measured at 50% of Waveform) |
| Load Drive Capability | 15pF Maximum |
| Output Logic Type | CMOS |
| Output Control Function | Tri-State (High Impedance Internal Pull Down Resistor of 100kOhms Typical on Pad 3, Internal Pull Up Resistor of 100kOhms Typical on Pad 1) |
| Tri-State Input Voltage (Vih and Vil) | 70% of Vdd Minimum or No Connection to Enable Output, 30% of Vdd Maximum to Disable Output |
| Tri-State Output Disable Time | 350nSec Maximum |
| Tri-State Output Enable Time | 350nSec Maximum |
| Disable Current | 20mA Maximum (Unloaded; Pad 1=Ground; Vdd=3.3Vdc) |
| Spread Spectrum | ±0.75% Center Spread |
| Modulation Frequency | 30kHz Minimum, 31.5kHz Typical, 33kHz Maximum |
| Period Jitter | 400pSec Maximum (Cycle to Cycle; Spread Spectrum-On; Vdd=3.3Vdc) |
| Start Up Time | 10mSec Maximum |
| Storage Temperature Range | -55°C to +125°C |

ENVIRONMENTAL & MECHANICAL SPECIFICATIONS

| | |
|------------------------------|---------------------------------------|
| Fine Leak Test | MIL-STD-883, Method 1014, Condition A |
| Gross Leak Test | MIL-STD-883, Method 1014, Condition C |
| Mechanical Shock | MIL-STD-202, Method 213, Condition C |
| Resistance to Soldering Heat | MIL-STD-202, Method 210 |
| Resistance to Solvents | MIL-STD-202, Method 215 |
| Solderability | MIL-STD-883, Method 2003 |
| Temperature Cycling | MIL-STD-883, Method 1010 |
| Vibration | MIL-STD-883, Method 2007, Condition A |

EPS13D2C1HC-45.000M

MECHANICAL DIMENSIONS (all dimensions in millimeters)

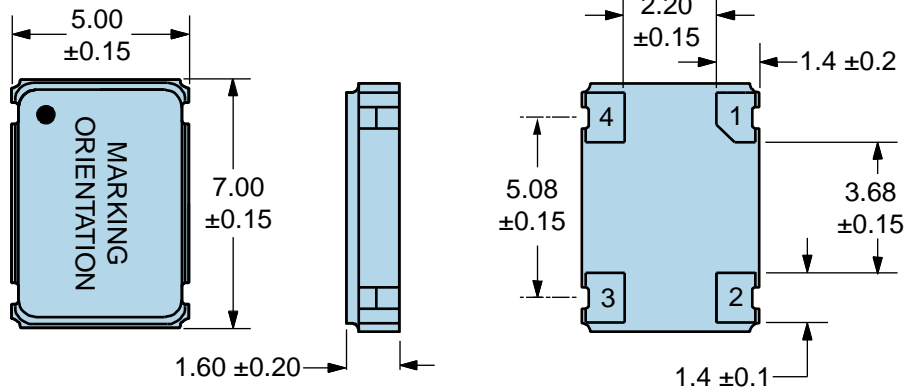

| PIN | CONNECTION |
|-----|----------------|
| 1 | Tri-State |
| 2 | Case/Ground |
| 3 | Output |
| 4 | Supply Voltage |

| LINE | MARKING |
|------|--|
| 1 | ECLIPTEK |
| 2 | 45.000M |
| 3 | SXXYYZ <i>S=Configuration Designator</i> <i>XX=Ecliptek Manufacturing Code</i> <i>Y=Last Digit of the Year</i> <i>ZZ=Week of the Year</i> |

Suggested Solder Pad Layout

All Dimensions in Millimeters

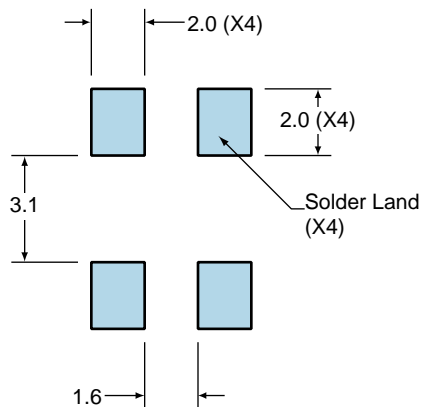

All Tolerances are ± 0.1

EPS13D2C1HC-45.000M

OUTPUT WAVEFORM & TIMING DIAGRAM



Test Circuit for CMOS Output



Note 1: An external 0.1 μ F low frequency tantalum bypass capacitor in parallel with a 0.01 μ F high frequency ceramic bypass capacitor close to the package ground and V_{DD} pin is required.

Note 2: A low capacitance (<12pF), 10X attenuation factor, high impedance (>10Mohms), and high bandwidth (>300MHz) passive probe is recommended.

Note 3: Capacitance value C_L includes sum of all probe and fixture capacitance.

Recommended Solder Reflow Methods



High Temperature Infrared/Convection

T_s MAX to T_L (Ramp-up Rate) 3°C/second Maximum

Preheat

- Temperature Minimum (T_s MIN) 150°C
- Temperature Typical (T_s TYP) 175°C
- Temperature Maximum (T_s MAX) 200°C
- Time (t_s MIN) 60 - 180 Seconds

Ramp-up Rate (T_L to T_p) 3°C/second Maximum

Time Maintained Above:

- Temperature (T_L) 217°C
- Time (t_L) 60 - 150 Seconds

Peak Temperature (T_p) 260°C Maximum for 10 Seconds Maximum

Target Peak Temperature (T_p Target) 250°C +0/-5°C

Time within 5°C of actual peak (t_p) 20 - 40 seconds

Ramp-down Rate 6°C/second Maximum

Time 25°C to Peak Temperature (t) 8 minutes Maximum

Moisture Sensitivity Level Level 1

Recommended Solder Reflow Methods



Low Temperature Infrared/Convection 240°C

| | |
|--|--|
| T_s MAX to T_L (Ramp-up Rate) | 5°C/second Maximum |
| Preheat | |
| - Temperature Minimum (T _s MIN) | N/A |
| - Temperature Typical (T _s TYP) | 150°C |
| - Temperature Maximum (T _s MAX) | N/A |
| - Time (t _s MIN) | 60 - 120 Seconds |
| Ramp-up Rate (T_L to T_p) | 5°C/second Maximum |
| Time Maintained Above: | |
| - Temperature (T _L) | 150°C |
| - Time (t _L) | 200 Seconds Maximum |
| Peak Temperature (T_p) | 240°C Maximum |
| Target Peak Temperature (T_p Target) | 240°C Maximum 1 Time / 230°C Maximum 2 Times |
| Time within 5°C of actual peak (t_p) | 10 seconds Maximum 2 Times / 80 seconds Maximum 1 Time |
| Ramp-down Rate | 5°C/second Maximum |
| Time 25°C to Peak Temperature (t) | N/A |
| Moisture Sensitivity Level | Level 1 |

Low Temperature Manual Soldering

185°C Maximum for 10 seconds Maximum, 2 times Maximum.

High Temperature Manual Soldering

260°C Maximum for 5 seconds Maximum, 2 times Maximum.