



SANYO Semiconductors

DATA SHEET

LA6585M

Monolithic Digital IC
For Motor Driver
BTL Driver Single-Phase Full-Wave

Overview

The LA6585M is single-phase bipolar fan motor is driven, through BTL output linear drive, at high efficiency, low power, and low sound by suppressing the reactive power. Lock protection, rotary signal circuits are incorporated, which is optimum for the notebook PC, consumer equipment power supply, car audio system, CPU cooler, etc. that require high reliability and low noise.

Functions and features

- Pre-driver for single-phase full-wave drive
- Single-phase full-wave linear drive by BTL output (gain resistance $1k\Omega$ - $360k\Omega$, 51dB)
 - : No switching noise, which is optimum for equipment requiring silence, such as consumer equipment power supply, car audio system, etc.
- Low-voltage operation possible, with wide operating voltage range (2.2 to 14.0V)
- Low saturation output (Upper + lower saturation voltage : V_{Osat} (total) = 1.2Vtyp, $I_O = 250mA$)
 - : High coil efficiency with low current drain. Additionally, IC itself generates only small heat.
- Built-in lock protection and automatic reset circuits
- Built-in FG & RD outputs
- Built-in Hall bias ($V_{HB} = 1.5V$)
- Thermal protection circuit
 - : When the large current flows due to output short-circuit and the IC chip temperature exceeds $180^\circ C$, this protective circuit suppresses the drive current to prevent burn and damage to IC.
- Extra-small & high heat capacity package

■ Any and all SANYO Semiconductor Co.,Ltd. products described or contained herein are, with regard to "standard application", intended for the use as general electronics equipment (home appliances, AV equipment, communication device, office equipment, industrial equipment etc.). The products mentioned herein shall not be intended for use for any "special application" (medical equipment whose purpose is to sustain life, aerospace instrument, nuclear control device, burning appliances, transportation machine, traffic signal system, safety equipment etc.) that shall require extremely high level of reliability and can directly threaten human lives in case of failure or malfunction of the product or may cause harm to human bodies, nor shall they grant any guarantee thereof. If you should intend to use our products for applications outside the standard applications of our customer who is considering such use and/or outside the scope of our intended standard applications, please consult with us prior to the intended use. If there is no consultation or inquiry before the intended use, our customer shall be solely responsible for the use.

■ Specifications of any and all SANYO Semiconductor Co.,Ltd. products described or contained herein stipulate the performance, characteristics, and functions of the described products in the independent state, and are not guarantees of the performance, characteristics, and functions of the described products as mounted in the customer's products or equipment. To verify symptoms and states that cannot be evaluated in an independent device, the customer should always evaluate and test devices mounted in the customer's products or equipment.

SANYO Semiconductor Co., Ltd.

TOKYO OFFICE Tokyo Bldg., 1-10, 1 Chome, Ueno, Taito-ku, TOKYO, 110-8534 JAPAN

LA6585M

Specifications

Absolute Maximum Ratings at $T_a = 25^\circ\text{C}$

Parameter	Symbol	Conditions	Ratings	Unit
Supply voltage	V_{CC} max		15	V
Allowable power dissipation	P_d max	Mounted on a specified board*	800	mW
Output current	I_{OUT} max		0.7	A
Output withstand voltage	V_{OUT} max		15	V
RD/FG output pin output withstand voltage	$V_{RD/FG}$ max		15	V
RD/FG output current	$I_{RD/FG}$ max		10	mA
HB output current	I_B max		10	mA
Operating temperature	T_{opr}		-30 to +90	$^\circ\text{C}$
Storage temperature	T_{stg}		-55 to +150	$^\circ\text{C}$

*: Mounted on a specified board: 114.3mm×76.1mm×1.6mm glass epoxy

Operating Conditions at $T_a = 25^\circ\text{C}$

Parameter	Symbol	Conditions	Ratings	Unit
Supply voltage	V_{CC}		2.2 to 14.0	V
Common-phase input voltage range of Hall input	V_{ICM}		0 to $V_{CC}-1.5$	V

Electrical Characteristics at $T_a = 25^\circ\text{C}$, $V_{CC} = 12\text{V}$, unless otherwise specified

Parameter	Symbol	Conditions	Ratings			Unit
			min	typ	max	
Circuit Current	I_{CC1}	During drive (CT = L)	3	6	9	mA
	I_{CC2}	During lock protection (CT = H)	2.5	5	7.5	mA
Lock detection capacitor charge current	I_{CT1}		0.9	1.2	1.5	μA
Capacitor discharge current	I_{CT2}		0.10	0.18	0.25	μA
Capacitor charge and discharge current ratio	R_{CT}	$R_{CD} = I_{CT1}/I_{CT2}$	5	6.5	8	-
CT charge voltage	V_{CT1}		1.3	1.5	1.7	V
CT discharge voltage	V_{CT2}		0.3	0.5	0.7	V
OUT output L saturation voltage	V_{OL}	$I_O = 200\text{mA}$		0.25	0.45	V
OUT output H saturation voltage	V_{OH}	$I_O = 200\text{mA}$		0.95	1.2	V
Hall input sensitivity	V_{HN}	Zero peak value (including offset and hysteresis)		7	15	mV
Hall bias voltage	V_{HB}	$I_{HB} = 5\text{mA}$	1.3	1.5	1.7	V
FG/RD output pin L voltage	$V_{FG/RD}$	$I_{RD/FG} = 5\text{mA}$		0.15	0.3	V
FG/RD output pin leak current	$I_{FG/RDL}$	$V_{RD/FG} = 15\text{V}$		1	30	μA

Truth Table

IN-	IN+	CT	OUT1	OUT2	FG	RD	Mode
H	L	L	H	L	L	L	During rotation
L	H		L	H	H		
-	-	H	off	off	-	H	During overheat protection

LA6585M

Package Dimensions

unit : mm (typ)

3086B

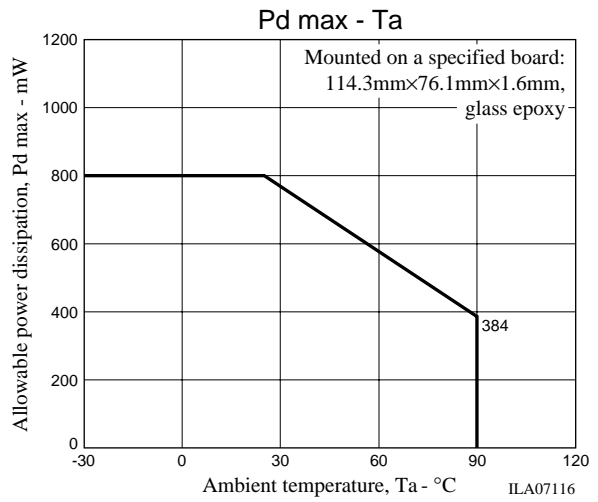
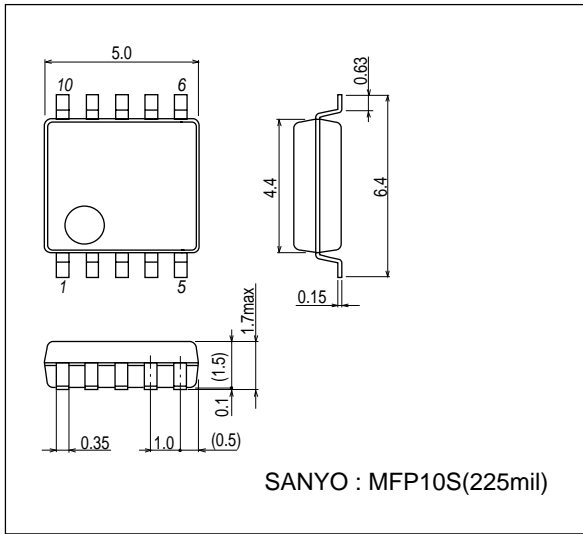

Block Diagram

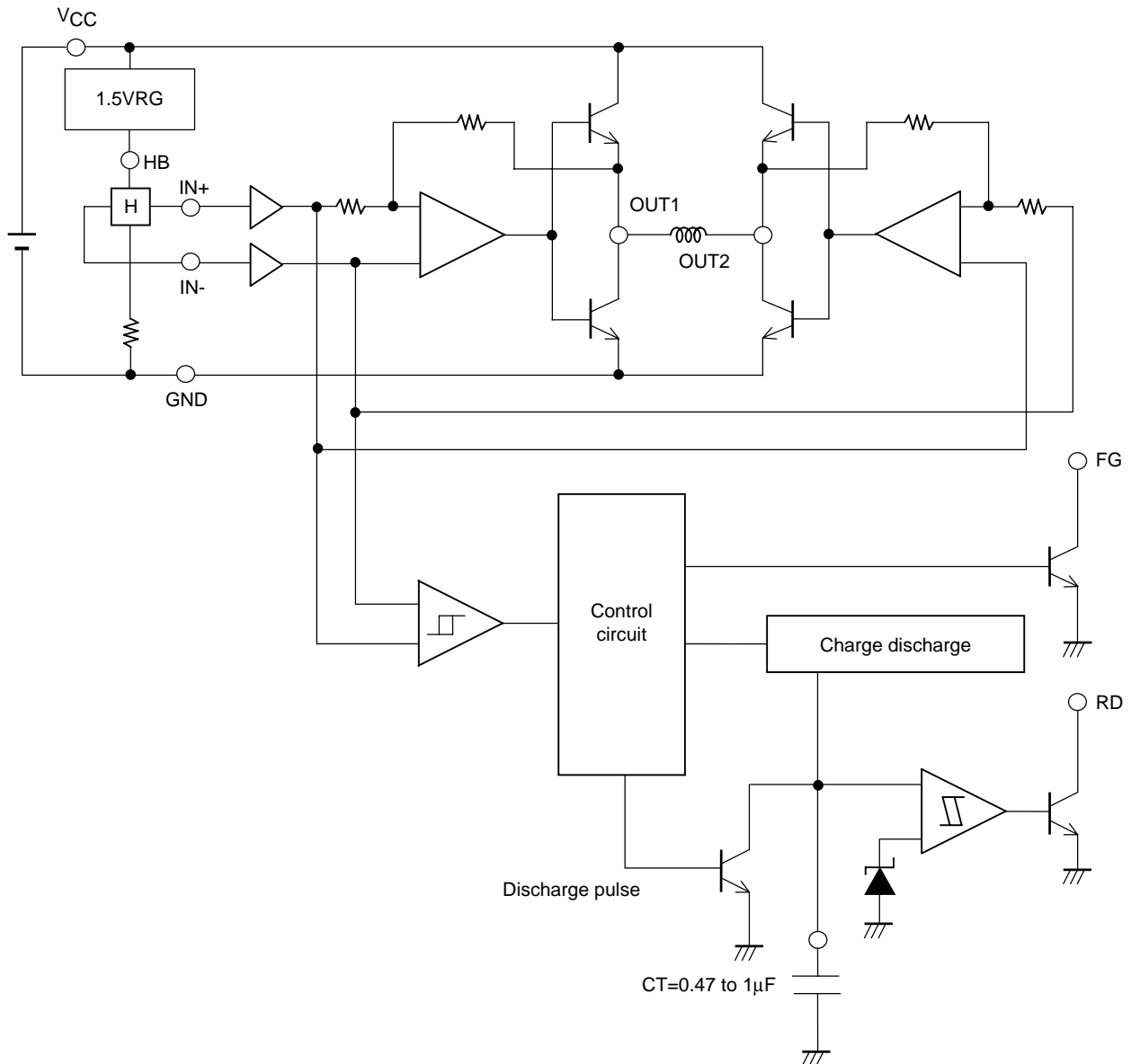

Pin Assignment

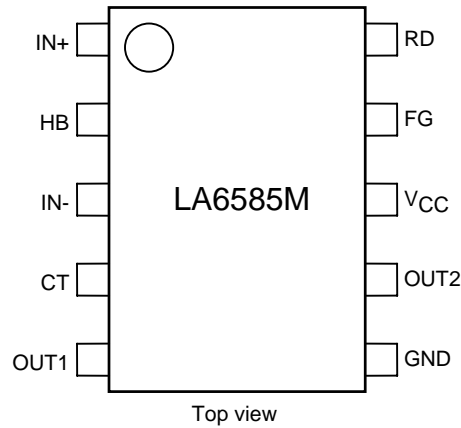

Sample Application Circuit

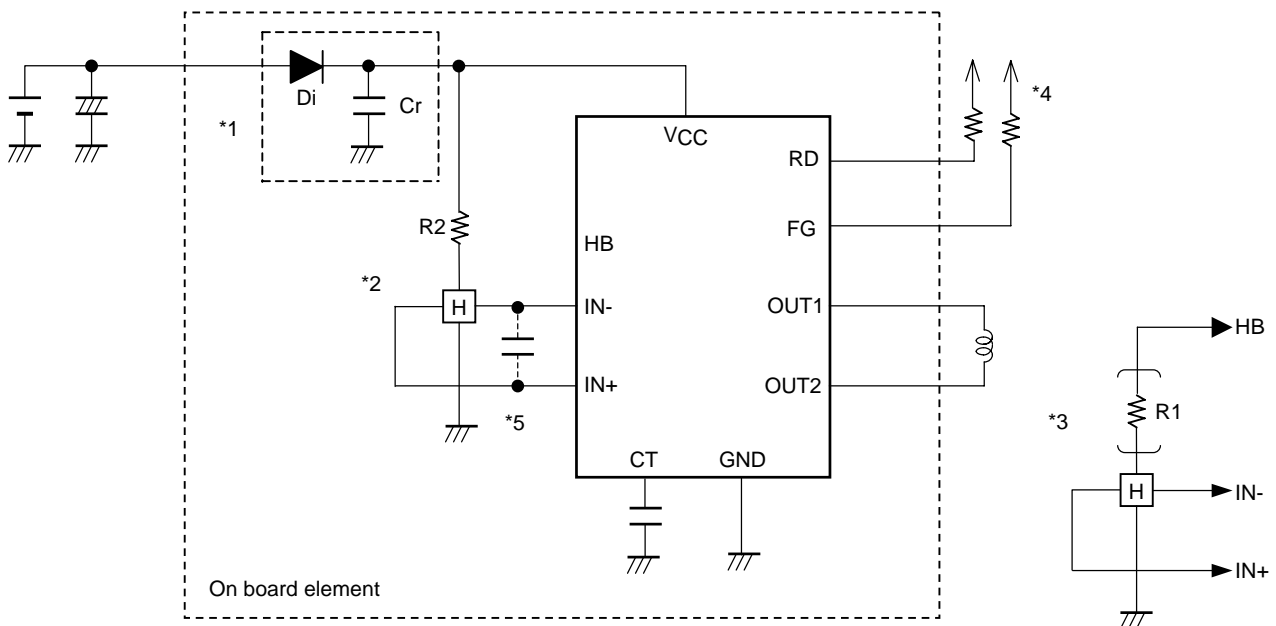

- *1: When the breakdown protective DI at reverse connection is to be used, it is necessary to insert the capacitor Cr to secure the regenerative current route. Similarly, Cr must be provided to enhance the reliability when there is no capacitor near the fan power line.
- *2: To obtain Hall bias from VCC, carry out bias to VCC with resistor R2 as shown in the figure. Linear driving is made through voltage control of the coil by amplifying the Hall output. When the Hall element output is large, the startup performance and efficiency are improved. Adjustment of the Hall element can reduce the noise further.
- *3: To obtain Hall bias from the HB pin, carry out constant-voltage bias at about 1.5V, which enables the Hall element to generate the stable Hall output satisfactory in temperature characteristics. Adjustment of the Hall output amplitude is made with R1. (When VCC=12V, the step *2 above proves advantageous for IC heat generation.)
- *4: Keep this open when not using.
- *5: When the wiring from the Hall output to IC Hall input is long, noise may be carried through the wiring. In this case, insert the capacitor as shown in the figure.

- SANYO Semiconductor Co.,Ltd. assumes no responsibility for equipment failures that result from using products at values that exceed, even momentarily, rated values (such as maximum ratings, operating condition ranges, or other parameters) listed in products specifications of any and all SANYO Semiconductor Co.,Ltd. products described or contained herein.
- SANYO Semiconductor Co.,Ltd. strives to supply high-quality high-reliability products, however, any and all semiconductor products fail or malfunction with some probability. It is possible that these probabilistic failures or malfunction could give rise to accidents or events that could endanger human lives, trouble that could give rise to smoke or fire, or accidents that could cause damage to other property. When designing equipment, adopt safety measures so that these kinds of accidents or events cannot occur. Such measures include but are not limited to protective circuits and error prevention circuits for safe design, redundant design, and structural design.
- In the event that any or all SANYO Semiconductor Co.,Ltd. products described or contained herein are controlled under any of applicable local export control laws and regulations, such products may require the export license from the authorities concerned in accordance with the above law.
- No part of this publication may be reproduced or transmitted in any form or by any means, electronic or mechanical, including photocopying and recording, or any information storage or retrieval system, or otherwise, without the prior written consent of SANYO Semiconductor Co.,Ltd.
- Any and all information described or contained herein are subject to change without notice due to product/technology improvement, etc. When designing equipment, refer to the "Delivery Specification" for the SANYO Semiconductor Co.,Ltd. product that you intend to use.
- Information (including circuit diagrams and circuit parameters) herein is for example only; it is not guaranteed for volume production.
- Upon using the technical information or products described herein, neither warranty nor license shall be granted with regard to intellectual property rights or any other rights of SANYO Semiconductor Co.,Ltd. or any third party. SANYO Semiconductor Co.,Ltd. shall not be liable for any claim or suits with regard to a third party's intellectual property rights which has resulted from the use of the technical information and products mentioned above.

This catalog provides information as of April, 2007. Specifications and information herein are subject to change without notice.