

# LJT00R (MS27466) — crimp wall mounting receptacle

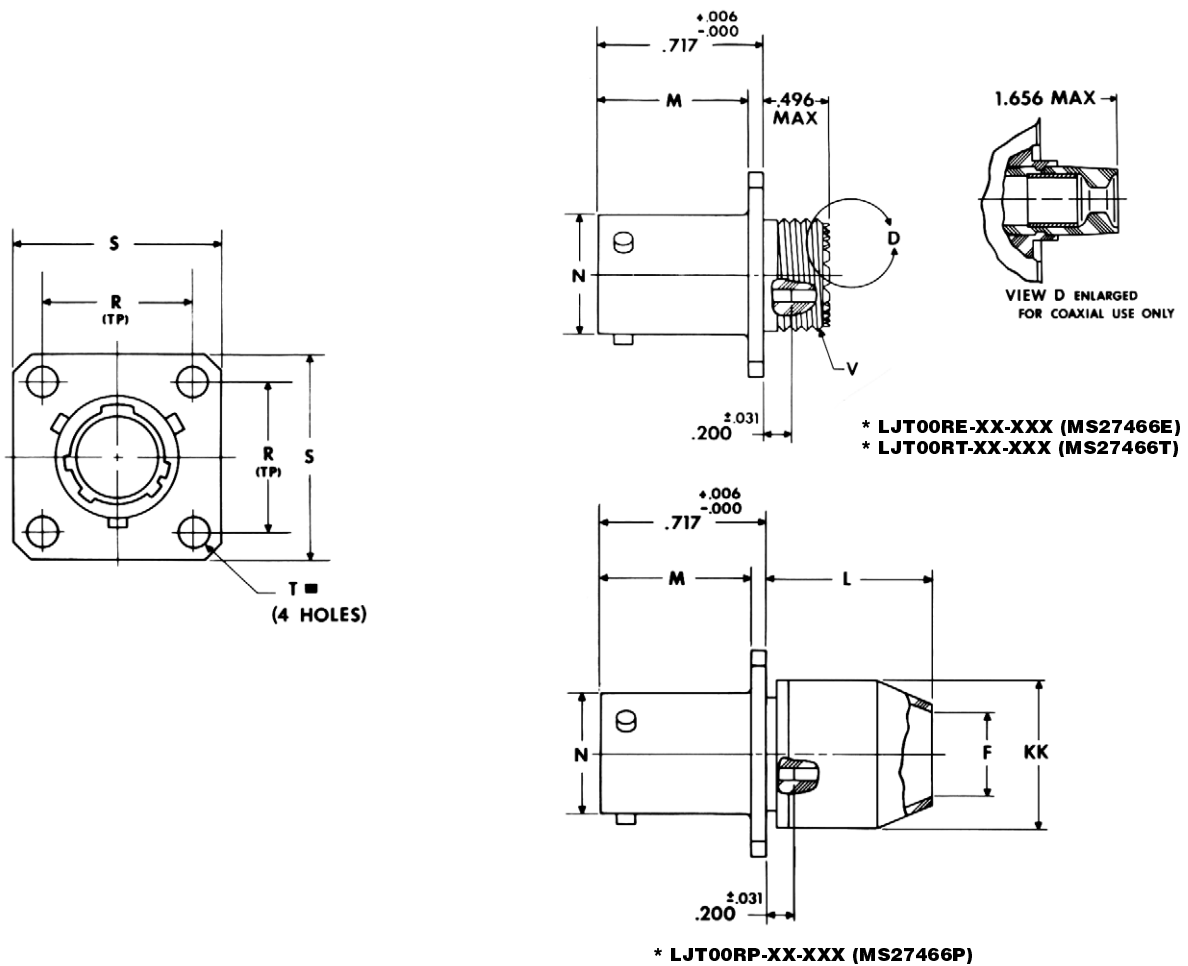

⊕ .005 DIA M

\* To complete order number see page 49.

Shell Size	F Dia.	L Max.	M +.000 -.005	N +.001 -.005	R (TP)	S ±.016	T Dia. ±.005	V Thread Class 2A (Plated)	KK Dia. Max.
9	.327	.813	.632	.572	.719	.938	.128	.4375-28 UNEF	.608
11	.444	.813	.632	.700	.812	1.031	.128	.5625-24 UNEF	.734
13	.558	.813	.632	.850	.906	1.125	.128	.6875-24 UNEF	.858
15	.683	.813	.632	.975	.969	1.219	.128	.8125-20 UNEF	.984
17	.808	.813	.632	1.100	1.062	1.312	.128	.9375-20 UNEF	1.110
19	.909	.813	.632	1.207	1.156	1.438	.128	1.0625-18 UNEF	1.234
21	1.034	.906	.602	1.332	1.250	1.562	.128	1.1875-18 UNEF	1.360
23	1.159	.906	.602	1.457	1.375	1.688	.147	1.3125-18 UNEF	1.484
25	1.284	.906	.602	1.582	1.500	1.812	.147	1.4375-18 UNEF	1.610

All dimensions for reference only.