

F9J €€ B @

BCHPG

```
%: (7) F9DF9G9BH5 7F#7 5@8A 9B€€B"
&"6l FF 5@€€ K 5B7.9."$S' O's, OA 5L"
* "D5FHGH' 69A C €8 98 'HC DC GHC B"
("A B A I A DI @€€ I H: CF 7.9.) "VQ&&" (BQ
)"7 CBH57 HA I GH69-B G9FH8 I BH@F9H8HC B: 95H F9@ 7?G-BHC D€57 9"
* "5 @€: B €- 98: C C 8G5F9HC '69 €M@F D57?5: 98 'B-G €-DB: "
* "CB@M5J 5-€6@-B HB D€5HB: "
: "5@D5FHGH' D5GG9@7 HF 7 5@H@GH DC B '5GG9A 6@MfB7 @ 8-B: < #DC H
H@G-BH%$S' J C @G87 L' 5: H@F: B 5@9@7 HF 7 5@H@GH €569@957 < 5GG9A 6@MK #K %€569@9H
: "5DD@7 5HC BG-BJC @ B: G9J 9F 969B8-B: F9E I F9* "A B A I A
: "7 56@ @B: H"
%$: CF 7 F A D 8 A 9BGC BG5B8 K F9DFC 79GG: 'G998K @%$LLLLL!LL'LL!LL!LL: CF:
: "DJ 7 5DD@7 5HC BGC F 8K @!$%$LLLLL!LL'LL!LL!LL: CF: 9D 5DD@7 5HC BG
%€' BC H 8 9@H98"
%€': CF @B: H-G@GG'H: 5B '%&-B ZHC @F5B7 9G<5@€69'-& "
: "69-%&) O %€ O: C F C H 9F @B: H-GZHC @F5B7 9GG<5@€69'-& "
% "5J 5-€6@9HC 9L €H: 7 I GCA 9FGCB@M8C BC H89G€: B-B 5GC: F9J €€ B <"
```

```
: 9D 7 56@C DHC B
@!H: 9D-BG €HC B
f€95J 96€B?: C F G€B85F8
DJ 7 'B-G €HC B€
```

```
Bc 'C: 'DC GHC BG
!$&HkF! '$
```

```
K F9: 5I: 9fBk; t
@99H56@%Q
DJ 7 .!%Z!% Z!$*Z!&$' Z!&Z!&(&
@: 9D. '!' Z!&(&
```

```
K F97C @CF
@5J 96€B?: CF 5@€67? K F9
7. 7 C @CF 7 C 898 K F9
fG997 C @CF G9E I 9B7 9H56@ZG-99H&L
fBC H5J 5-€6@K #K: 9D'C DHC B€
```

@958 GHM@

```
!GD. G€B85F8' DC K 9F f7!% -!LL!GD!H€
!<D. <€ < DC K 9F f7!% -!LL!<D!H€
: "FG99 BC H@ %€
```

C DHC B

```
Q I GH69I G98 'CB '8 '9B8 'C DHC B:
' "CB@W' 5DD@GHC '9B8 &<C I G-B: O
!@ G €H7 < I DZGF5 € <H
: "FG99: € " ZG<99H&L
!@G €H7 < 8CK BZGF5 € <H
: "FG99: € " (ZG<99H&L
```

9B8 'C DHC B

```
!G 'GB: @9B8
!8. 8C I 6@9B8'
: "fA I GH7 < C C G9@ G C F @G C DHC B G€
```

5GG9A 6@8 @B: H€

```
GD97 € M-B 'B7 < 9GfB' '$$ -B7 < A -B A I A t
Q G98K 7 LLLLLLLLLLQ
```

fBc 'C: DC GI ("%') Q "% Q
Z "\$(\$O%\$&€F9.

"% [+ -] F9:
"€&]" (%) F9:

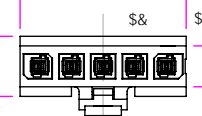

5" @68!LL!G

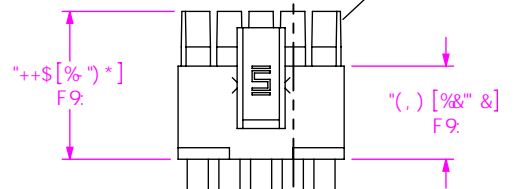

5" DA GGL!\$)!LL!LL!LL"LL!G<C K B

G97 HC B "5 1"5"

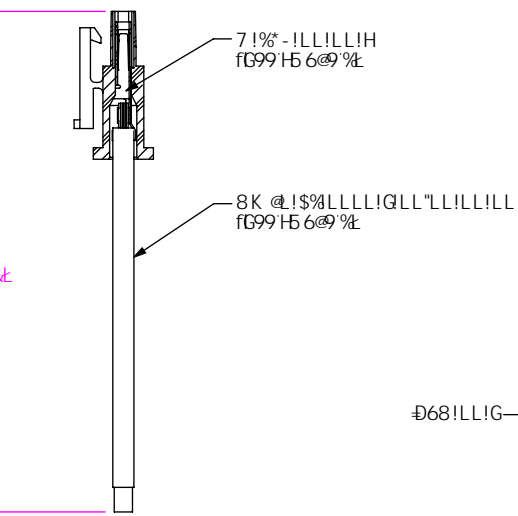

7% LL'LL
fG99 BC H@ %€L

7% LL'LL
fG99 BC H@ %€L

@68!LL!G

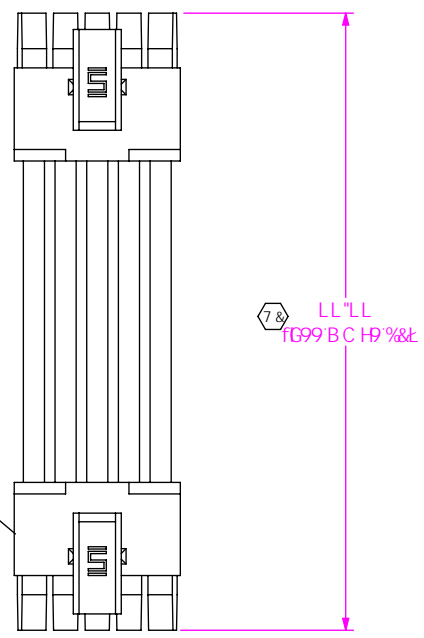

8C BCH
G7 5@: FCA
H €DF-BH

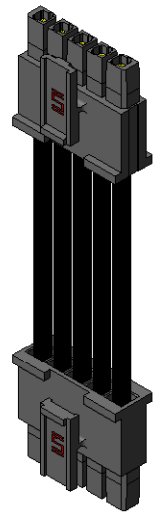

TABLE 1

SERIES	CABLE AWG	CABLE	CONTACT
PMSS	16 AWG	DWC-16-XX-600	C-169-03-XX-T
PMSS	18 AWG	DWC-18-XX-600	C-169-03-XX-T
PMSS	206 AWG	DWC-20-XX-600	C-169-03-XX-T
PMSS	203 AWG	DWC-20-XX-300	C-169-02-XX-T
PMSS	22 AWG	DWC-22-XX-300	C-169-02-XX-T
PMSS	24 AWG	DWC-24-XX-300	C-169-02-XX-T
PMSST	18 AWG	DWCT-18-01	C-169-03-XX-T
PMSST	24 AWG	DWCT-24-01	C-169-02-XX-T

† BCHF9@95G98: C F DFC 8I 7 HC B

```
I B @GG C H 9FK €9 (D97 € 98Z
8 A 9BGC BG5F9-B 'B7 < 9G"
HC @F5B7 9G 5F9.
897 A 5@€: "5B: @G
"LL. ±"$%O' O' "€&"
"LLL. ±"$S) O%€ O
"LLLL. ±"$S&S O's) %Q
```

```
DFC.DF-9H5FMBCH@
H-€8C 71A 9B7C B1€ 8G€: CFA 5HC B
7CB: 89B€ 5B8 DFCDF 9€FMC
G5A H7Z B7 "5B8 G5@BC H69F90FC 8I 7 9B
C F H5BG 9F98 HC C H: 9F 8C 71A 9BHGCF
8 47 @C 98 HC C H: 9F GCF I G98: C F 5BM
DI FDC 9C H: 9F H5B H: 5HK < 7 < H: 5G
C 6H5 898 K #€ C I H: 9LDF 9G98 K F H@B
7CB@98HC: G5A H7Z B7 "
```

```
A 5HF-6€ 8C 'BCH G7 5@9 8F5K B: G-99HG7 5@9 %€
<C I G-B: 'J 5@€L ( ) +27 C @CF. B5H F5@
7CBH57HD<C G6FC BN9
7 56@/B G €HC B. G997 5€€C I H
: "K #9. G997 56@DFBH
: "fBC H@58: F99€
: .PBK: PA €7PA ?H PDA GGL!LL!LL!LL!LL!LL!LL!LL!LL!LL?HG88FK
```



&\$ D5F? 95GH6@ 8ZB9K 5€5BM-B (+) \$
D<C B9, %&L-((1* + " €L, %&L- (,) \$ (+
YIA UJ. bZ: 4 G5A H7 "W€a "€XY.)') &&

8967 F@HC B.
"%) Q "% QGC 7? 9H8 €7 F99H7 56@ 5GG9A 6@M
8K: "BC"
DA GGL!LL!LL!LL!LL!LL"LL!LL!LL
6M 895B D \$(#)? (#&\$S) G<99H% C: &

