

Service Manual

Pioneer

DEH-1100/X1M/UC

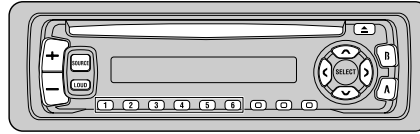

ORDER NO.
CRT2433

HIGH POWER CD PLAYER WITH FM/AM TUNER

DEH-1100

DEH-11

X1M/UC

X1M/UC

● This service manual should be used together with the following manual(s):

Model No.	Order No.	Mech. Module	Remarks
CX-958	CRT2423	S8.1	CD Mech. Module:Circuit Description, Mech.Description, Disassembly

CONTENTS

1. SAFETY INFORMATION	2	7. GENERAL INFORMATION	45
2. EXPLODED VIEWS AND PARTS LIST	2	7.1 DIAGNOSIS	45
3. BLOCK DIAGRAM AND SCHEMATIC DIAGRAM	8	7.1.1 TEST MODE	45
4. PCB CONNECTION DIAGRAM	26	7.1.2 DISASSEMBLY	48
5. ELECTRICAL PARTS LIST	36	7.2 PARTS	52
6. ADJUSTMENT	41	7.2.1 IC.....	52
		7.2.2 DISPLAY	58
		7.3 OPERATIONAL FLOW CHART	59
		8. OPERATIONS AND SPECIFICATIONS.....	60

PIONEER CORPORATION 4-1, Meguro 1-Chome, Meguro-ku, Tokyo 153-8654, Japan
PIONEER ELECTRONICS SERVICE INC. P.O.Box 1760, Long Beach, CA 90801-1760 U.S.A.
PIONEER ELECTRONIC [EUROPE] N.V. Haven 1087 Keetberglaan 1, 9120 Melsele, Belgium
PIONEER ELECTRONICS ASIACENTRE PTE.LTD. 253 Alexandra Road, #04-01, Singapore 159936

www.DataSheet4U.com

© PIONEER CORPORATION 1999

K-ZZA. NOV. 1999 Printed in Japan

● **CD Player Service Precautions**

1. For pickup unit(CXX1285) handling, please refer to "Disassembly"(see page 48).
During replacement, handling precautions shall be taken to prevent an electrostatic discharge(Protection by a short pin).

2. During disassembly, be sure to turn the power off since an internal IC might be destroyed when a connector is plugged or unplugged.
3. Please check the grating after changing the service pickup unit(see page 43).

1. SAFETY INFORMATION

CAUTION

This service manual is intended for qualified service technicians; it is not meant for the casual do-it-yourselfer. Qualified technicians have the necessary test equipment and tools, and have been trained to properly and safely repair complex products such as those covered by this manual. Improperly performed repairs can adversely affect the safety and reliability of the product and may void the warranty. If you are not qualified to perform the repair of this product properly and safely; you should not risk trying to do so and refer the repair to a qualified service technician.

WARNING

This product contains lead in solder and certain electrical parts contain chemicals which are known to the state of California to cause cancer, birth defects or other reproductive harm.
Health & Safety Code Section 25249.6 - Proposition 65

2. EXPLODED VIEWS AND PARTS LIST

2.1 PACKING

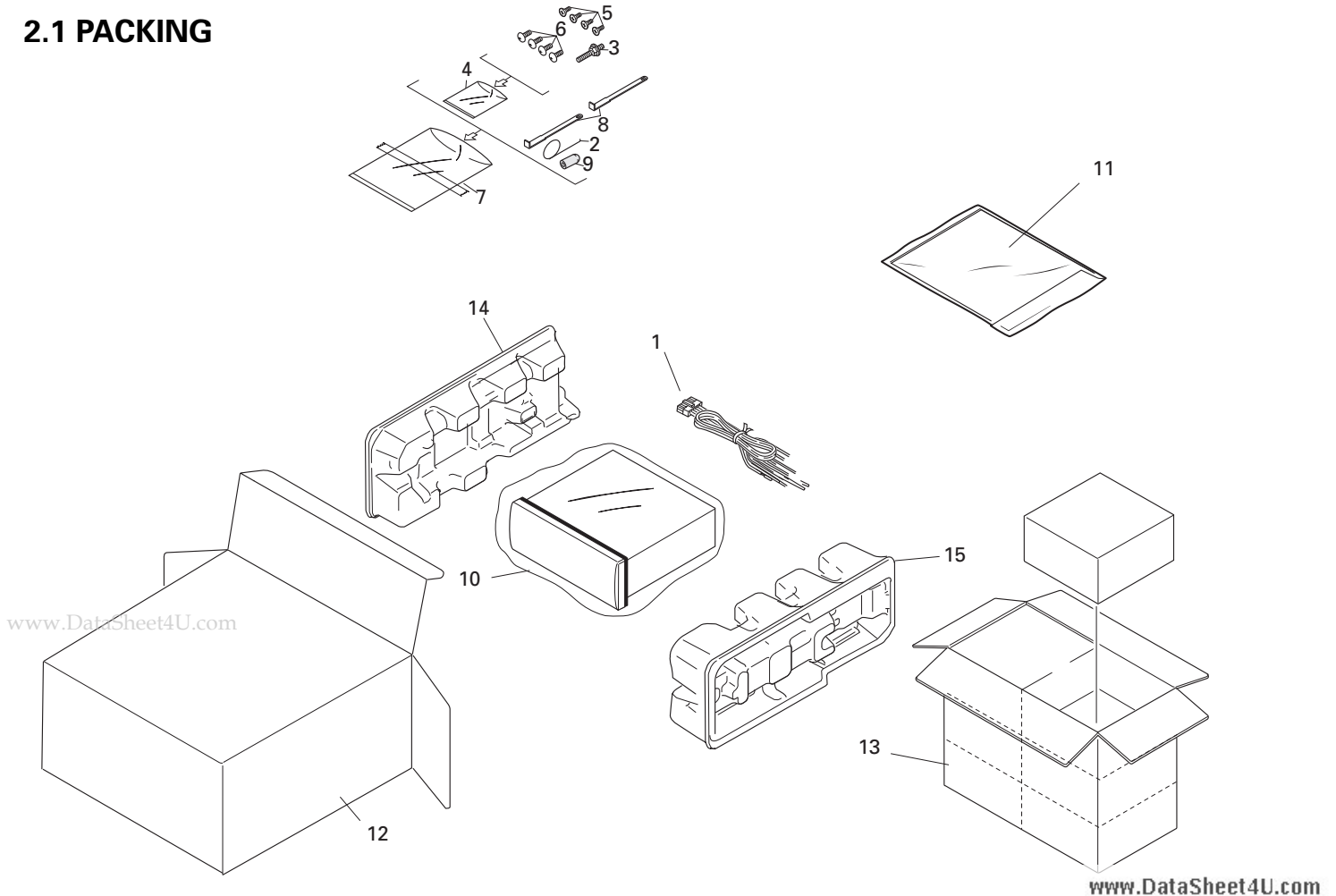

NOTE:

- Parts marked by "*" are generally unavailable because they are not in our Master Spare Parts List.
- Screws adjacent to ∇ mark on the product are used for disassembly.

(1) PACKING SECTION PARTS LIST

Mark No.	Description	Part No.	Mark No.	Description	Part No.
	1 Cord Assy	CDE6124	11-1	Polyethylene Bag	CEG1116
	2 Spring	CBH1650	11-2	Owner's Manual	CRD3133
	3 Screw	CBA1002	11-3	Installation Manual	CRD3134
*	4 Polyethylene Bag	CEG-127	* 11-4	Card	ARY1048
	5 Screw	CRZ50P090FMC	12	Carton	See Contrast table(2)
	6 Screw	TRZ50P080FMC	13	Contain Box	See Contrast table(2)
*	7 Polyethylene Bag	CEG-158	14	Protector	CHP2243
	8 Handle	CNC5395	15	Protector	CHP2244
	9 Bush	CNV3930			
	10 Polyethylene Bag	CEG1173			

(2) CONTRAST TABLE

DEH-1100/X1M/UC and DEH-11/X1M/UC are constructed the same except for the following:

Mark No.	Symbol and Description	Part No.	
		DEH-1100/X1M/UC	DEH-11/X1M/UC
12	Carton	CHG3953	CHG3954
13	Contain Box	CHL3953	CHL3954

● Owner's Manual, Installation Manual

Model	Part No.	Language
DEH-1100/X1M/UC	CRD3133	English, French, Spanish
DEH-11/X1M/UC	CRD3134	

2.2 EXTERIOR

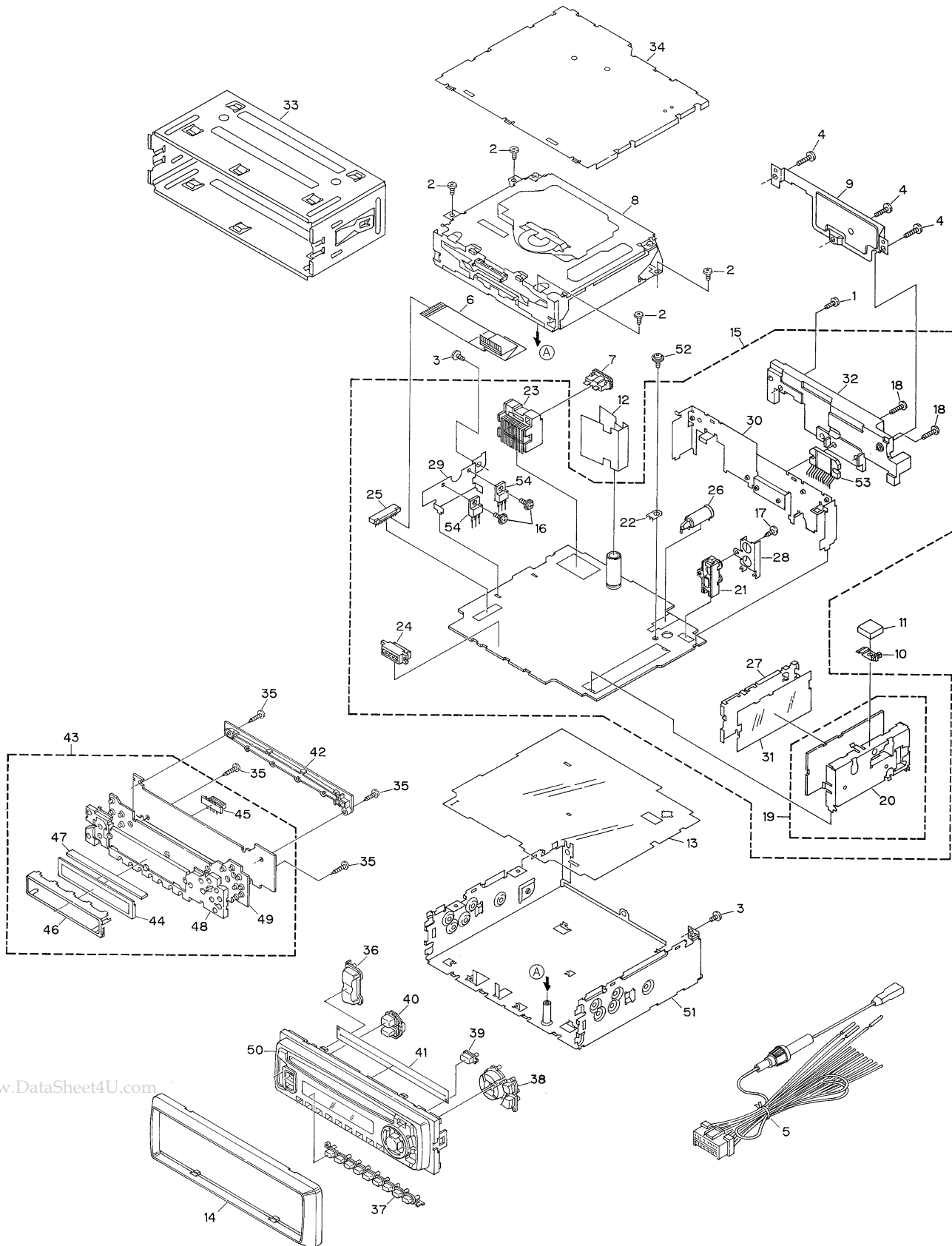

(1) EXTERIOR SECTION PARTS LIST

Mark No.	Description	Part No.	Mark No.	Description	Part No.
1	Screw	BMZ26P120FMC	31	Insulator	CNM5967
2	Screw	BSZ26P060FMC	32	Heat Sink	CNR1506
3	Screw	BSZ30P060FMC	33	Holder Unit	CXB2687
4	Screw	BSZ30P120FMC	34	Case Unit	CXB4033
5	Cord Assy	CDE6124	35	Screw	BPZ20P080FMC
6	Cable	CDE6160	36	Button(+, -)	CAC6273
7	Fuse(10A)	CEK1136	37	Button(1-6)	CAC6275
8	CD Mechanism Module(S8.1)	CXK5203	38	Button(B, A, Cross)	CAC6276
9	Cover	CNC8367	39	Button(Eject)	CAC6277
10	Holder	CNC8884	40	Button(Source)	CAC6495
11	Spacer	CNM4913	41	Cover	CNM6434
12	Insulator	CNM6224	42	Holder	CNV5963
13	Insulator	CNM6386	43	Keyboard Unit	See Contrast table(2)
14	Panel	CNS5132	44	LCD(LCD1801)	CAW1560
15	Tuner Amp Assy	CWM6769	45	Connector(CN1801)	CKS3580
16	Screw	ASZ26P080FMC	46	Holder	CNC8517
17	Screw	BPZ26P080FMC	47	Rubber	CNV5954
18	Screw	BSZ26P160FMC	48	Lighting Conductor	CNV5965
19	FM/AM Tuner Unit	CWE1501	49	Rubber	CNV5966
20	Holder	CNC7532	50	Grille Unit	See Contrast table(2)
21	Pin Jack(CN301)	CKB1041	51	Chassis Unit	CXB4625
22	Terminal(CN403)	CKF1059	52	Screw	ISS26P055FUC
23	Connector(CN901)	CKM1299	53	IC(IC302)	TDA7384
24	Connector(CN601)	CKS3581	54	Transistor(Q904, 981)	2SD2396
25	Connector(CN605)	CKS3838			
26	Antenna Jack(CN402)	CKX1056			
27	Holder	CNC7533			
28	Holder	CNC8041			
29	Holder	CNC8043			
30	Holder	CNC8588			

(2) CONTRAST TABLE

DEH-1100/X1M/UC and DEH-11/X1M/UC are constructed the same except for the following:

Mark No.	Symbol and Description	Part No.	
		DEH-1100/X1M/UC	DEH-11/X1M/UC
43	Keyboard Unit	CWM6783	CWM6782
50	Grille Unit	CXB4619	CXB4620

www.DataSheet4U.com

2.3 CD MECHANISM MODULE

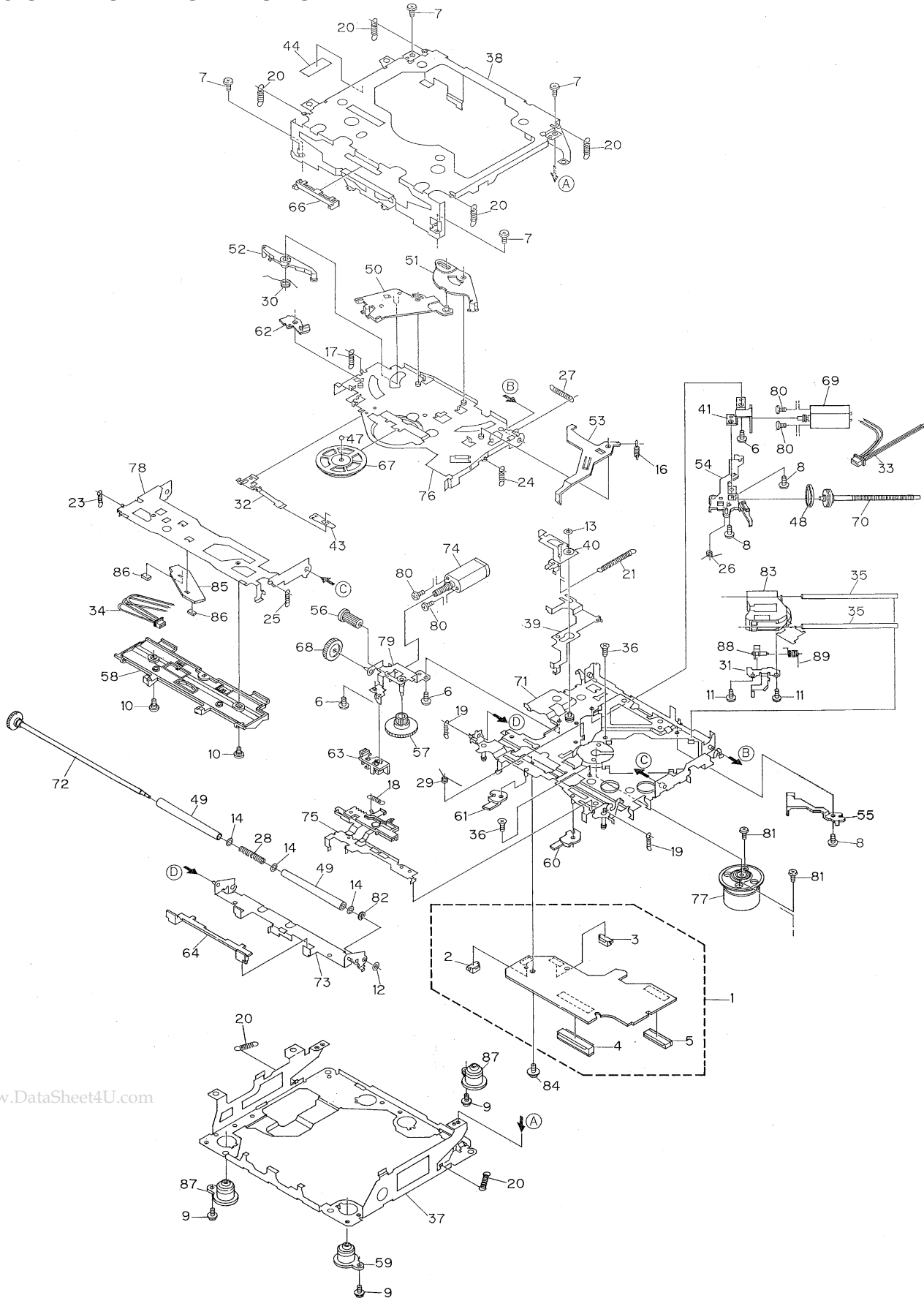

● CD MECHANISM MODULE SECTION PARTS LIST

Mark No.	Description	Part No.	Mark No.	Description	Part No.
1	Control Unit	CWX2411	46	*****	
2	Connector(CN802)	CKS2192	47	Ball	CNR1189
3	Connector(CN801)	CKS2193	48	Belt	CNT1086
4	Connector(CN701)	CKS2773	49	Roller	CNV4509
5	Connector(CN101)	CKS3486	50	Arm	CNV6037
6	Screw	BMZ20P030FMC	51	Arm	CNV5247
7	Screw	BSZ20P040FMC	52	Arm	CNV5248
8	Screw(M2x3)	CBA1077	53	Arm	CNV5249
9	Screw(M2x5)	EBA1028	54	Guide	CNV5254
10	Screw	CBA1243	55	Guide	CNV5255
11	Screw(M2x4)	CBA1362	56	Gear	CNV5257
12	Washer	CBF1037	57	Gear	CNV5256
13	Washer	CBF1038	58	Guide	CNV6176
14	Washer	CBF1060	59	Damper	CNV6174
15	*****		60	Arm	CNV6096
16	Spring	CBH2079	61	Arm	CNV6031
17	Spring	CBH2117	62	Arm	CNV6211
18	Spring	CBH2314	63	Guide	CNV6012
19	Spring	CBH2110	64	Guide	CNV5510
20	Spring	CBH2282	65	*****	
21	Spring	CBH2318	66	Guide	CNV5751
22	*****		67	Clamper	CNV6013
23	Spring	CBH2324	68	Gear	CNV5813
24	Spring	CBH2118	69	Motor Unit(M1)	CXB2190
25	Spring	CBH2161	70	Screw Unit	CXB4726
26	Spring	CBH2163	71	Chassis Unit	CXB4797
27	Spring	CBH2189	72	Gear Unit	CXB4728
28	Spring	CBH2249	73	Arm Unit	CXB4729
29	Spring	CBH2260	74	Motor Unit(M2)	CXB2195
30	Spring	CBH2262	75	Lever Unit	CXB4730
31	Bracket	CNC8568	76	Arm Unit	CXB4731
32	Spring	CBL1369	77	Motor Unit(M3)	CXB2562
33	Connector	CDE5531	78	Arm Unit	CXB4732
34	Connector	CDE5532	79	Bracket Unit	CXB4795
35	Shaft	CLA3304	80	Screw	JFZ20P025FMC
36	Screw(M2.6x6)	CBA1458	81	Screw	JGZ17P025FZK
37	Frame	CNC8565	82	Washer	YE20FUC
38	Frame	CNC8749	83	Pickup Unit(Service)(P8)	CXX1285
39	Lever	CNC7546	84	Screw	IMS26P030FMC
40	Arm	CNC8663	85	PCB	CNX2982
41	Bracket	CNC8567	86	Photo-transistor(Q1, 2)	CPT230SX-TU
42	*****		87	Damper	CNV6175
43	Spacer	CNM3315	88	Rack	CNV6014
44	Sheet	CNM6659	89	Spring	CBH2315
45	*****				

3. BLOCK DIAGRAM AND SCHEMATIC DIAGRAM

3.1 BLOCK DIAGRAM

A TUNER AMP ASSY

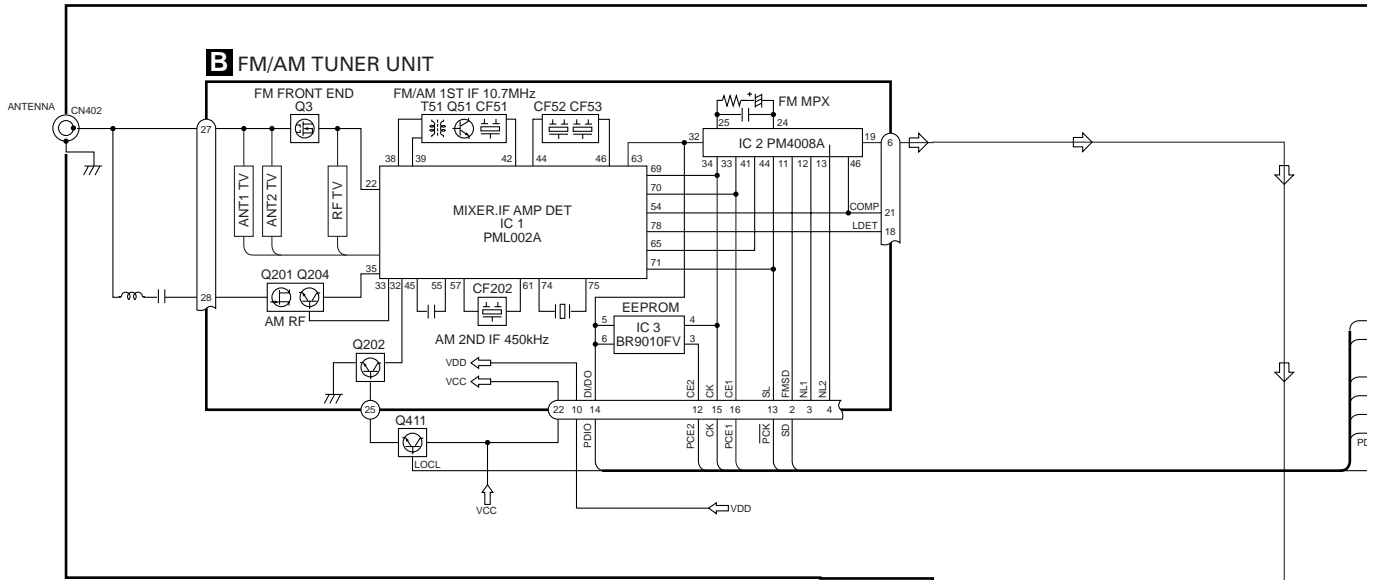

D CONTROL UNIT

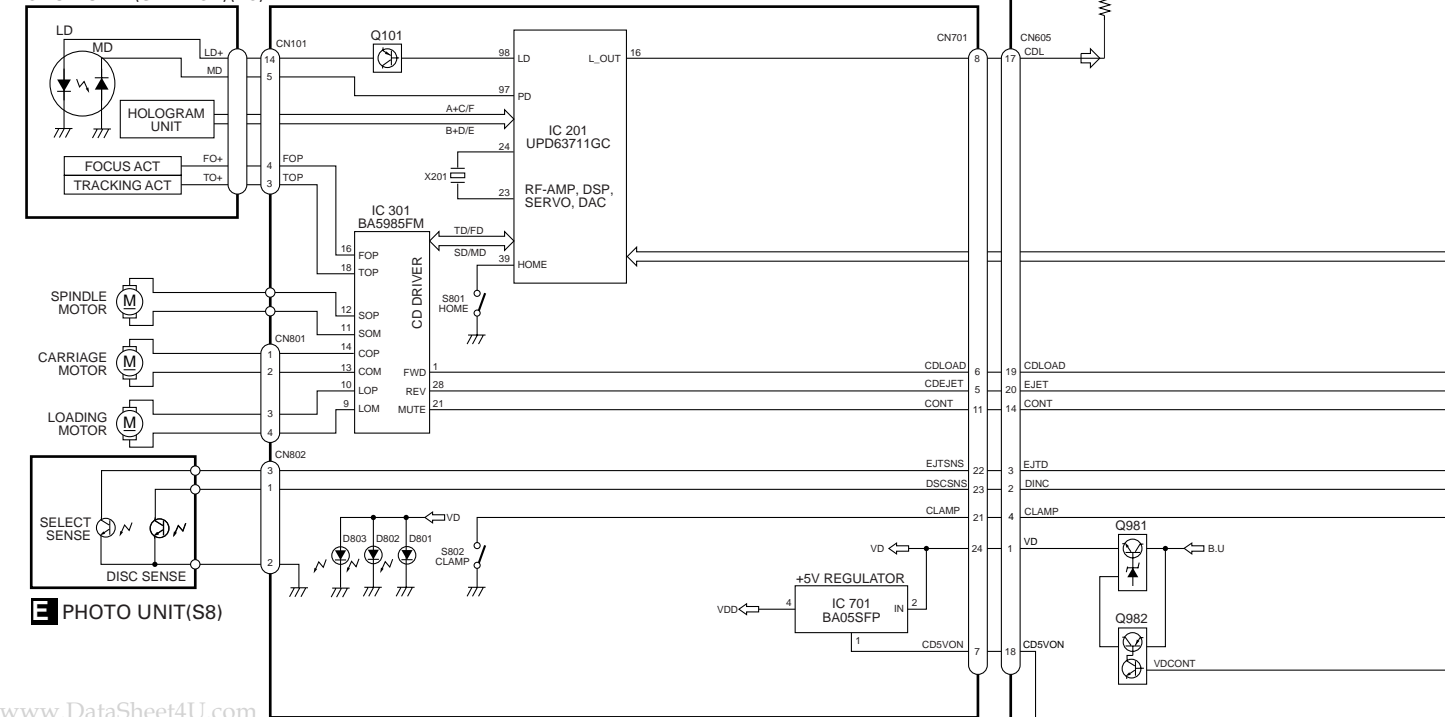

www.DataSheet4U.com

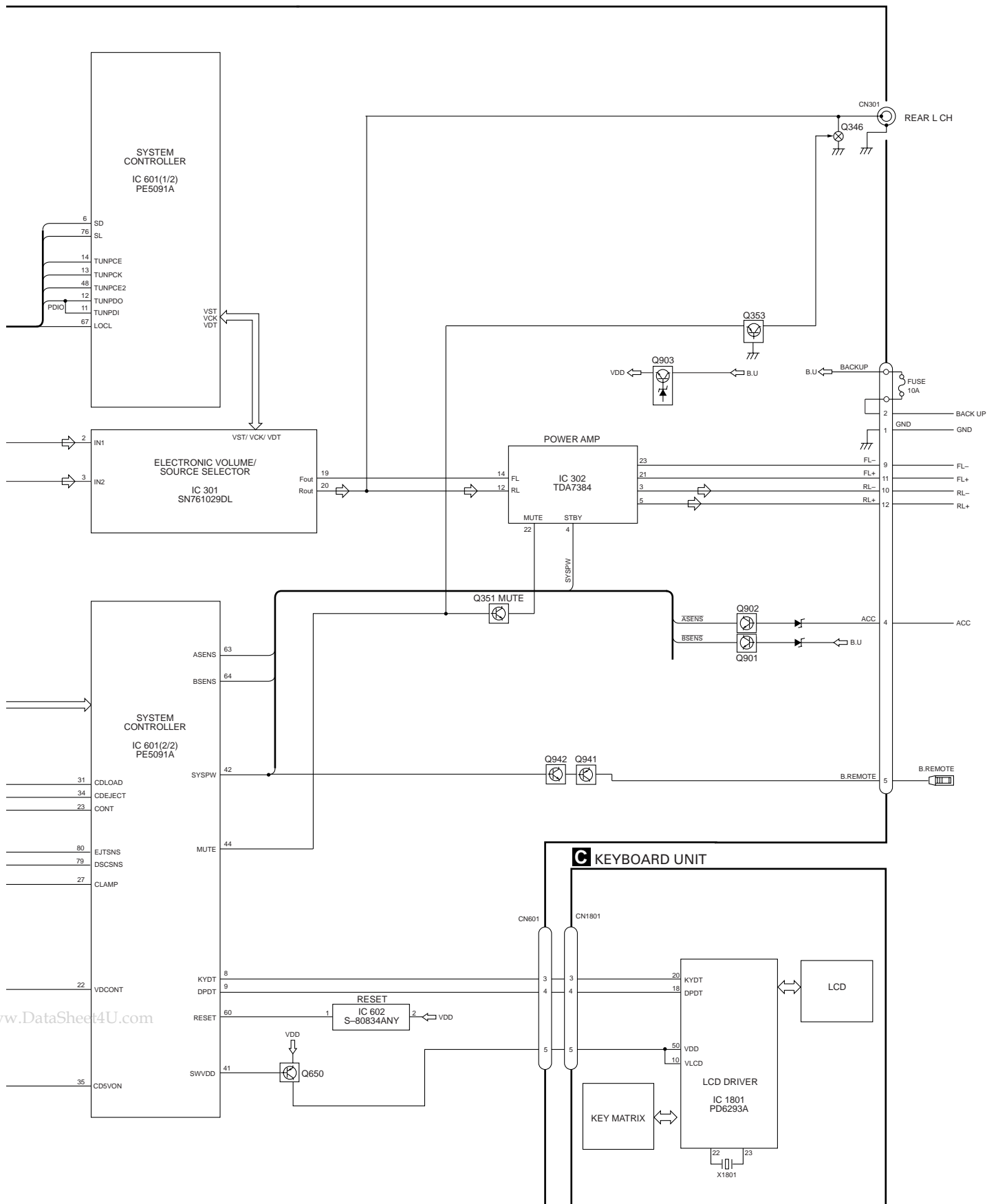

www.DataSheet4U.com

www.DataSheet4U.com

3.2 OVERALL CONNECTION DIAGRAM(GUIDE PAGE)

Note: When ordering service parts, be sure to refer to "EXPLODED VIEWS AND PARTS LIST" or "ELECTRICAL PARTS LIST".

A-a

B FM/AM TUNER UNIT

C KEYBOARD UNIT

SYSTEM CONTROLLER

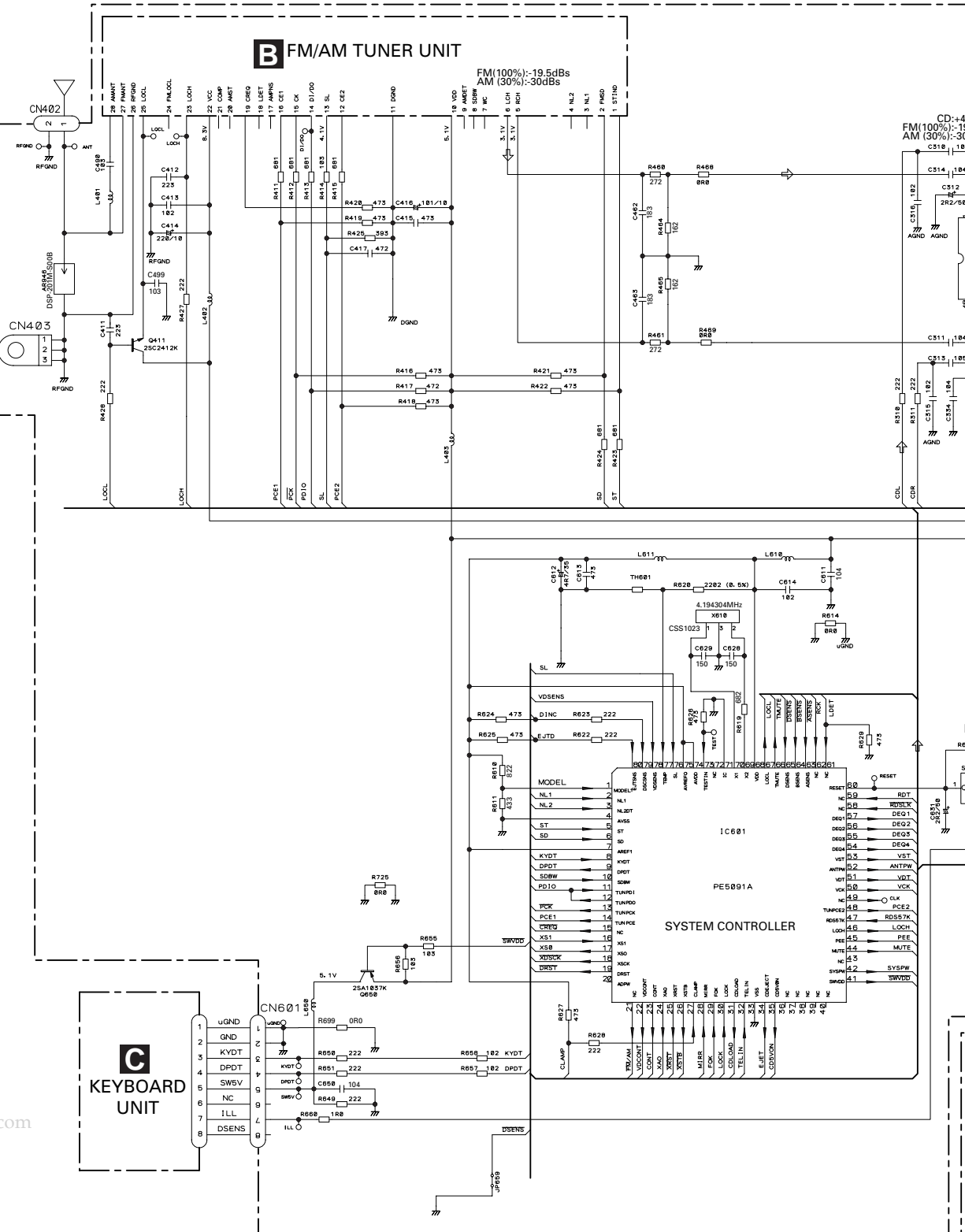

NOTE:

- Symbol indicates a resistor. No differentiation is made between chip resistors and discrete resistors.
- Symbol indicates a capacitor. No differentiation is made between chip capacitors and discrete capacitors.

The Δ mark found on some component parts indicates the importance of the safety factor of the part. Therefore, when replacing, be sure to use parts of identical designation.

For resistors and capacitors in the circuit diagrams, their resistance values or capacitance values are expressed in codes:

Ex. *Resistors

Code	Practical value
123	12k ohms
103	10k ohms

*Capacitors

Code	Practical value
103	0.01 μ F
101/10	100pF/10V

A

B

C

D

www.DataSheet4U.com

www.DataSheet4U.com



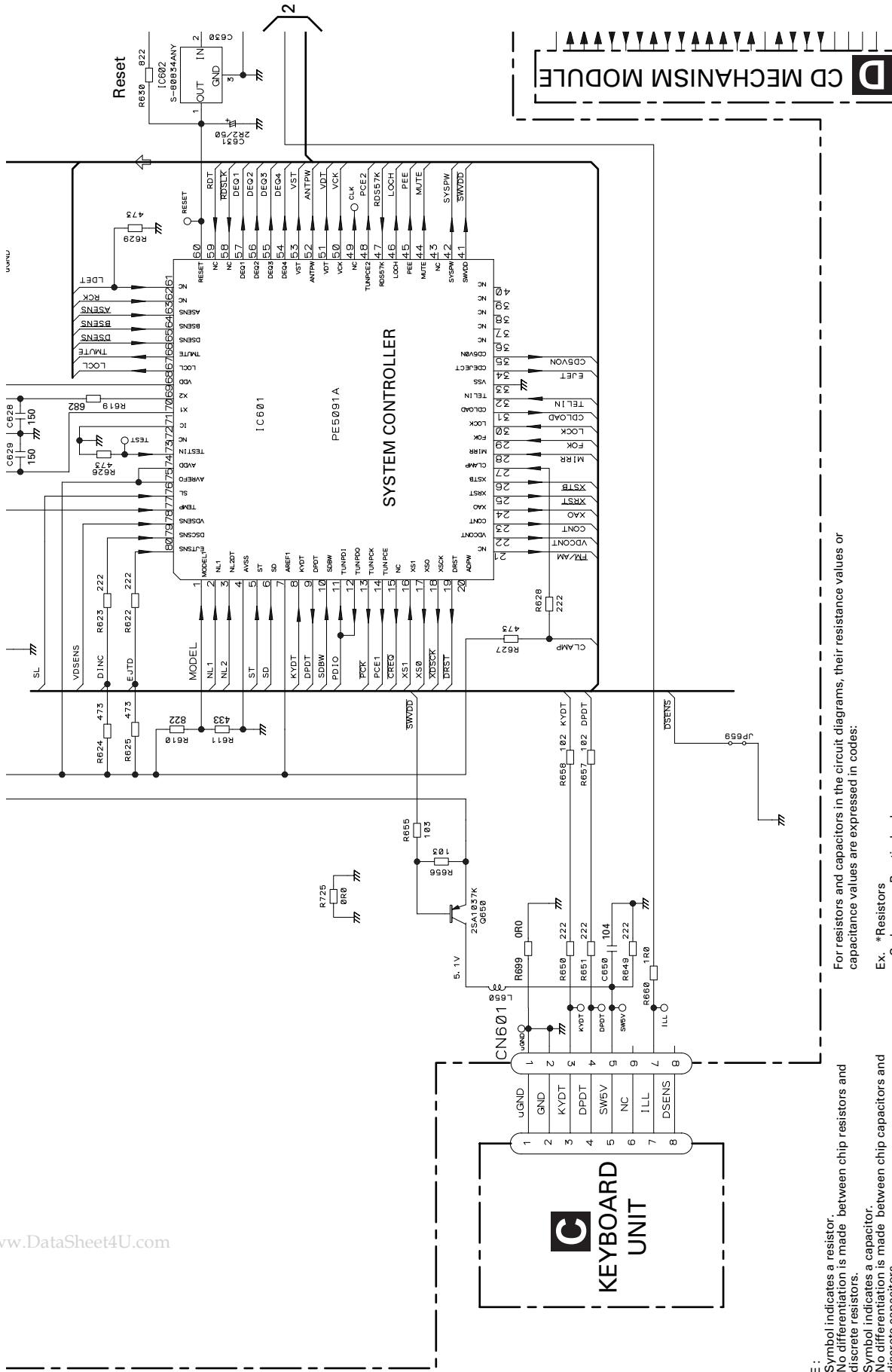

NOTE :

- Symbol indicates a resistor.
- No differentiation is made between chip resistors and discrete resistors.
- Symbol indicates a capacitor.
- No differentiation is made between chip capacitors and discrete capacitors.

The Δ mark found on some component parts indicates the importance of the safety factor of the part. Therefore, when replacing, be sure to use parts of identical designation.

For resistors and capacitors in the circuit diagrams, their resistance values or capacitance values are expressed in codes:

Ex. *Resistors

Code	Practical value
123	12k ohms
103	10k ohms

*Capacitors

Code	Practical value
103	0.01uF
101/10	100uF/10V

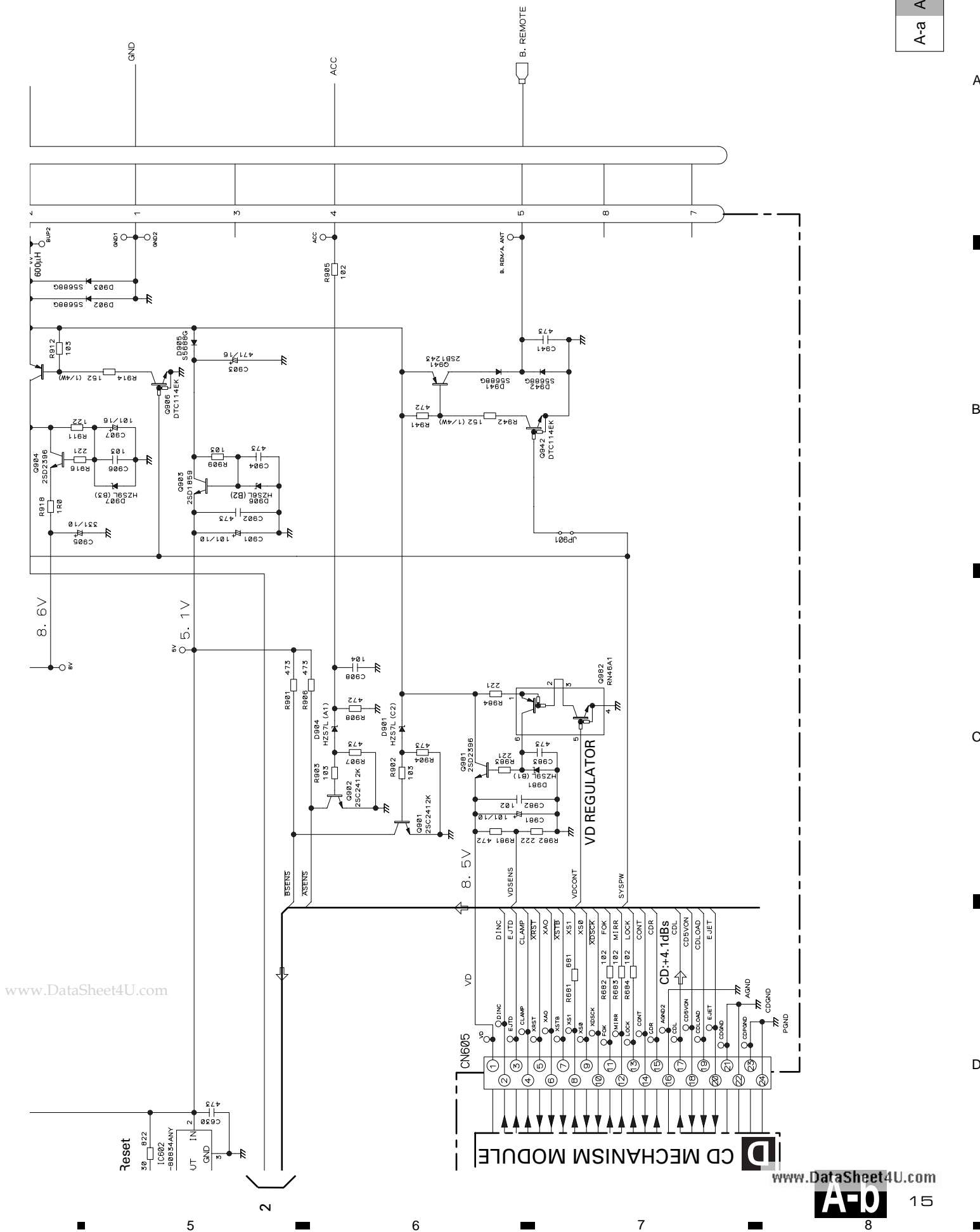

www.DataSheet4U.com

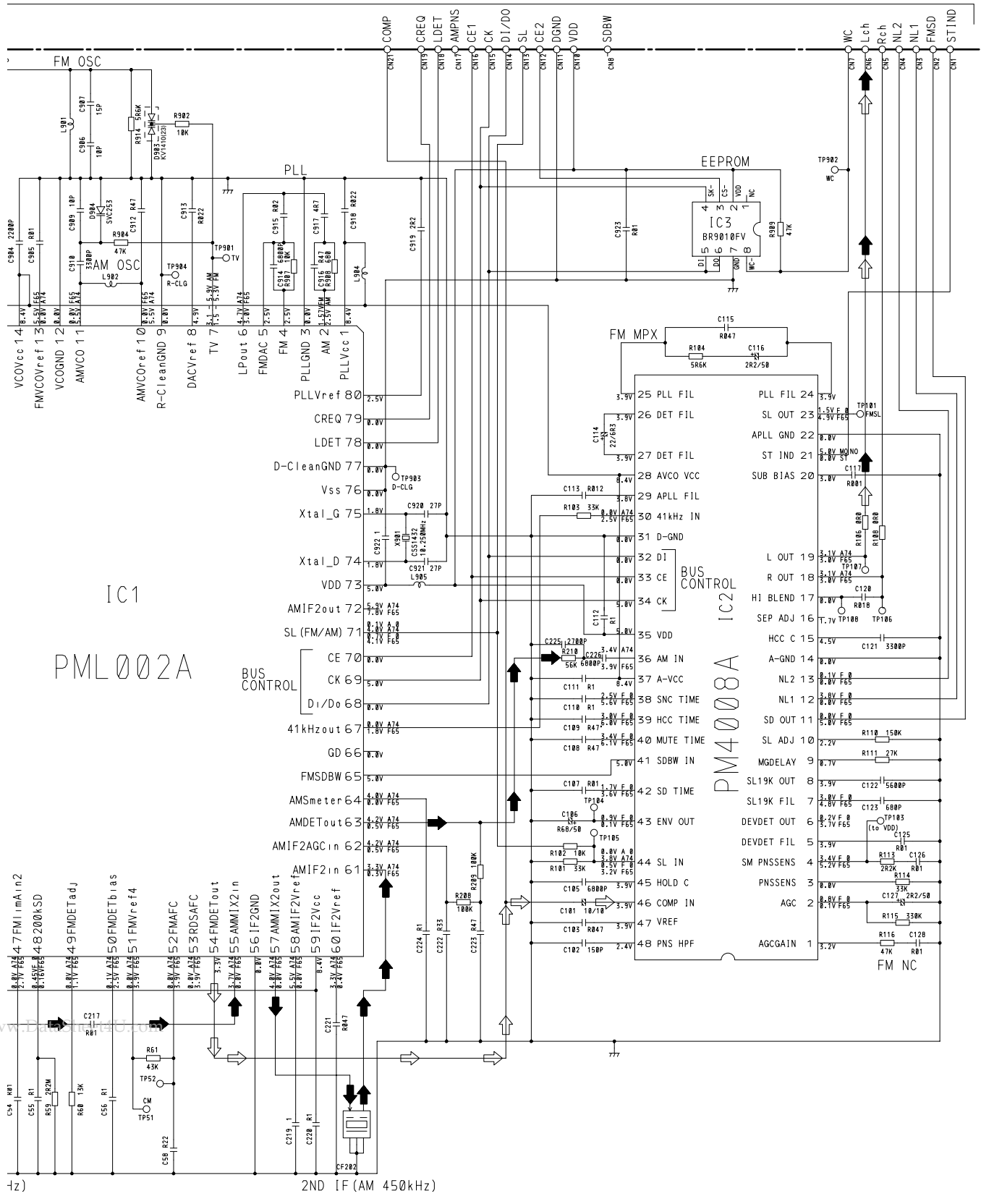

A

B

C

D

1 2 3 4

DEH-1100,11

3.4 KEYBOARD UNIT

C KEYBOARD UNIT

A

B

C

D

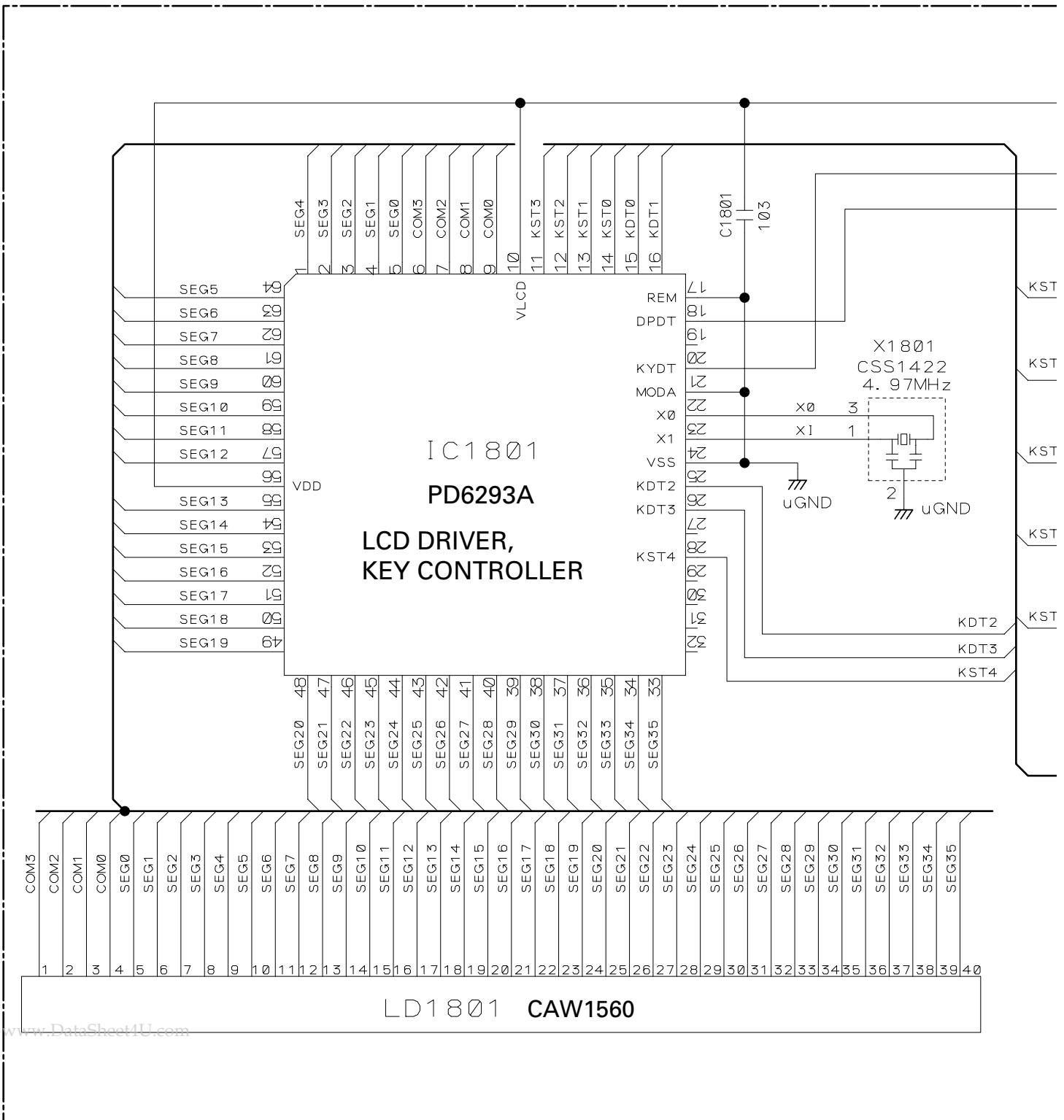

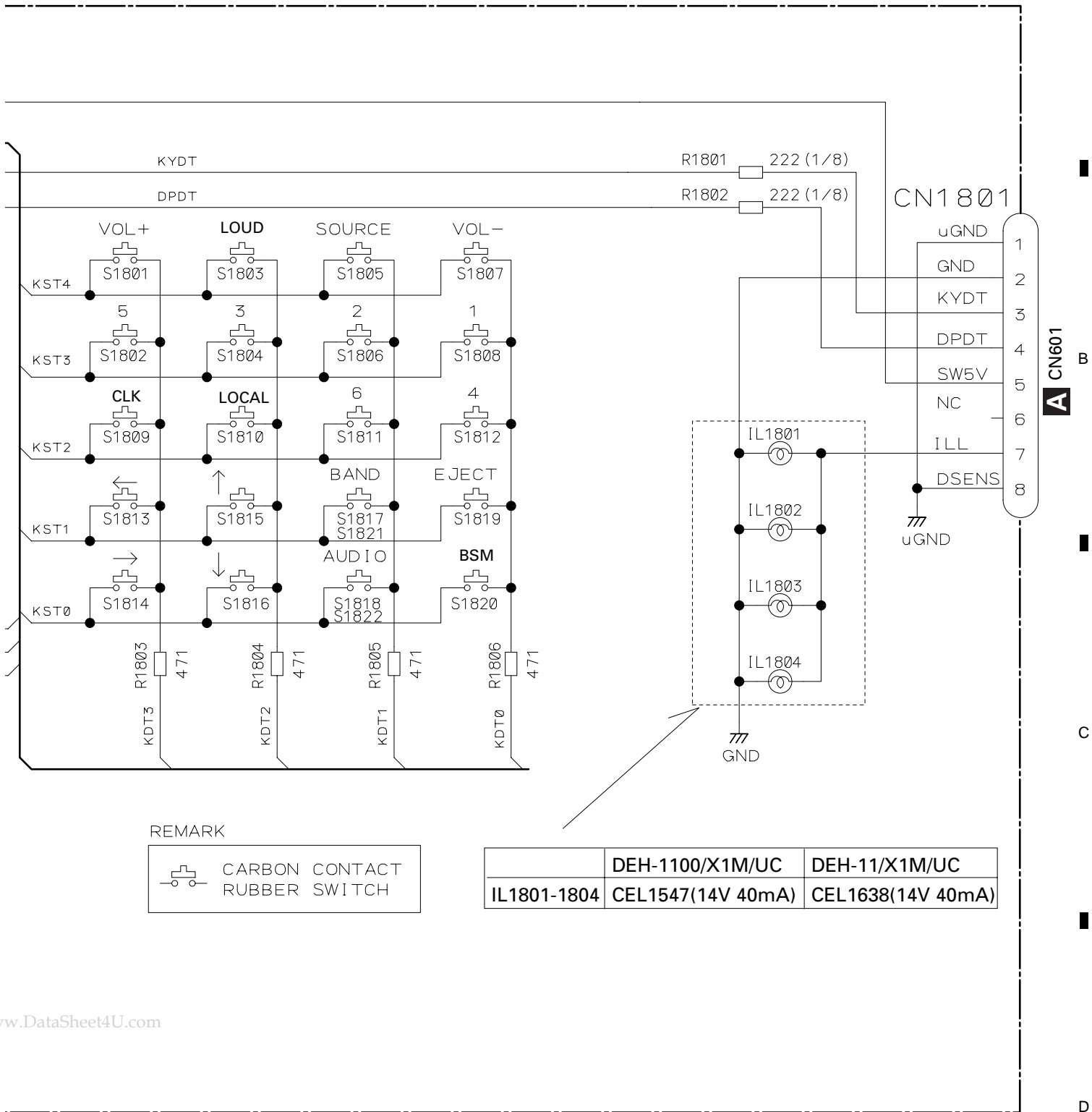

REMARK



3.5 CD MECHANISM MODULE

D CONTROL UNIT

PICKUP UNIT (SERVICE)(P8)

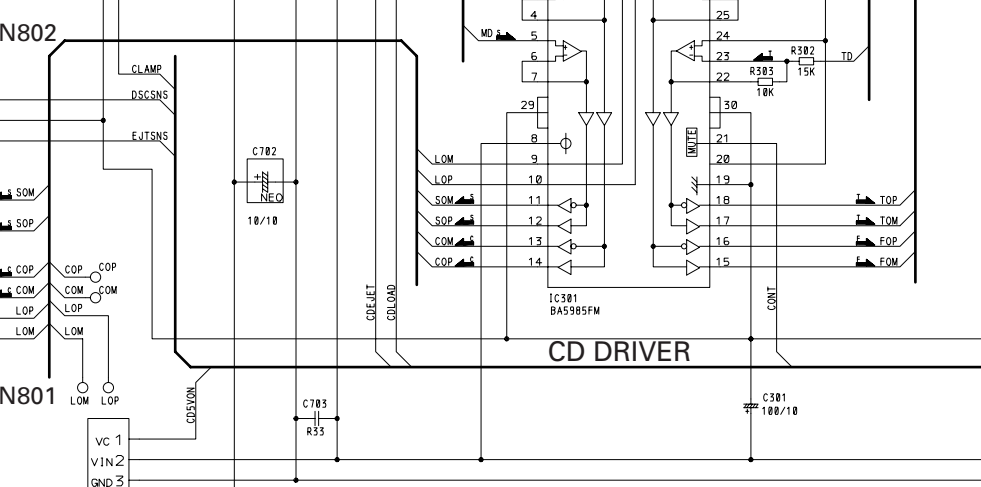
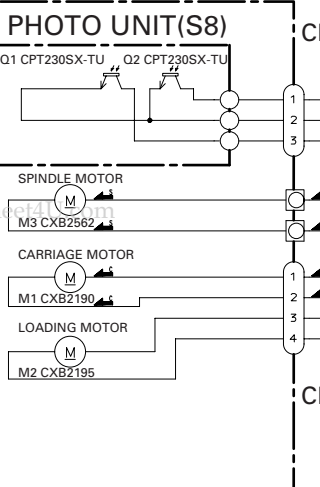
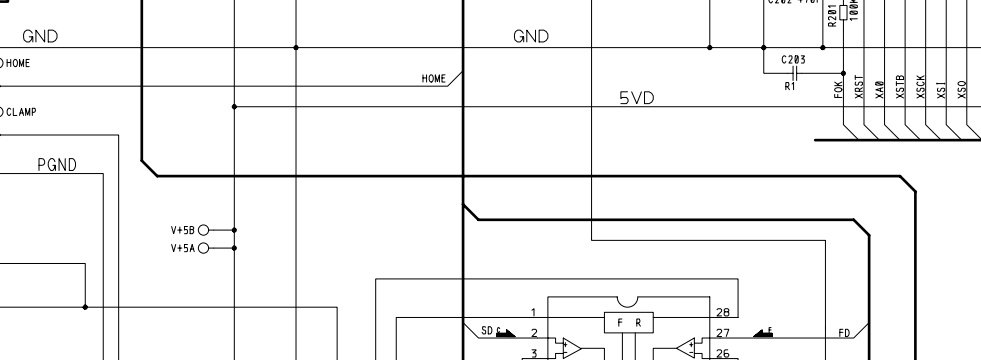
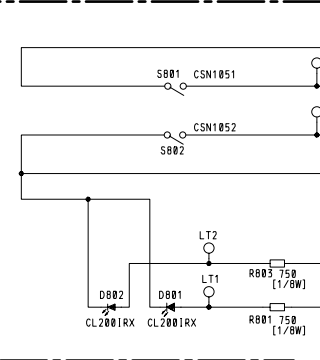
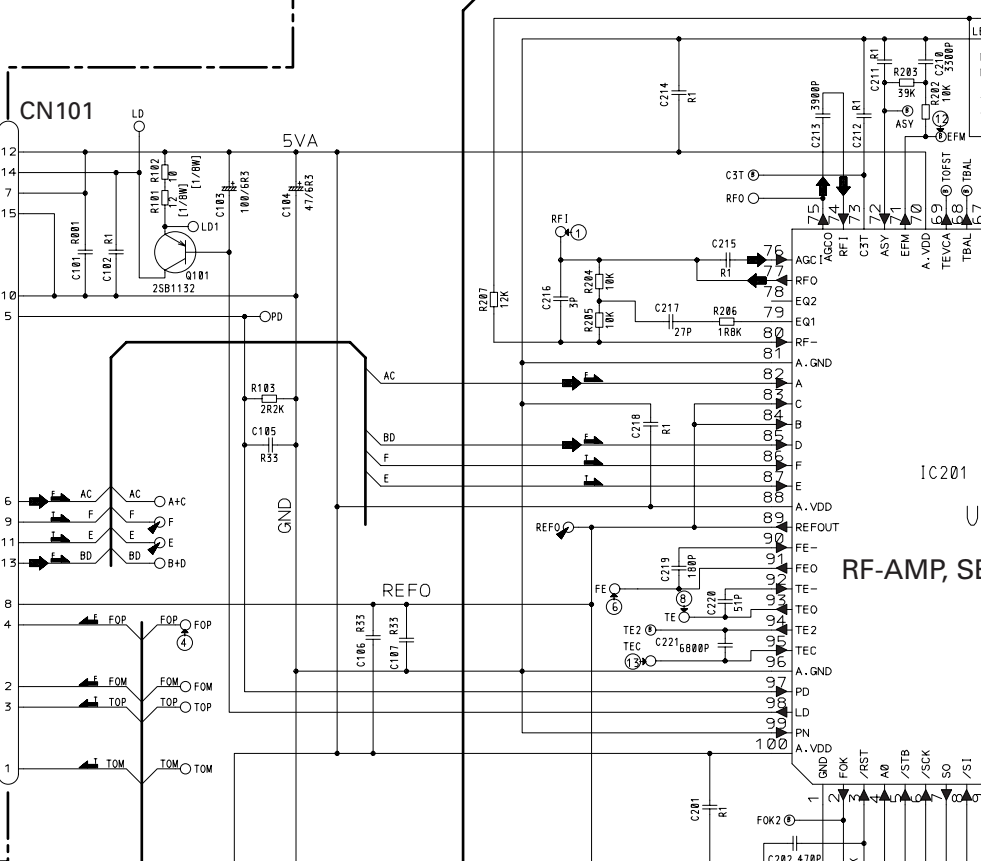
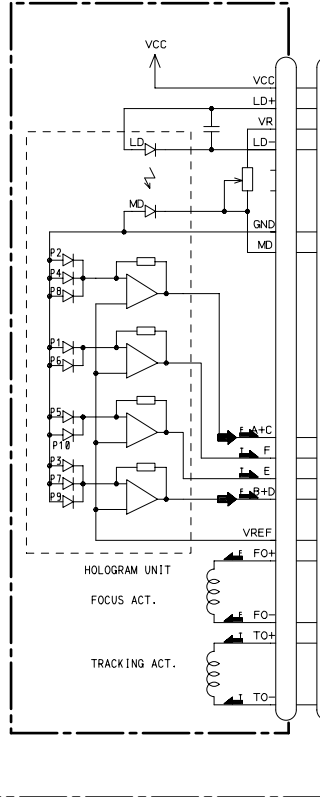

A

B

C

D

20 **D E**

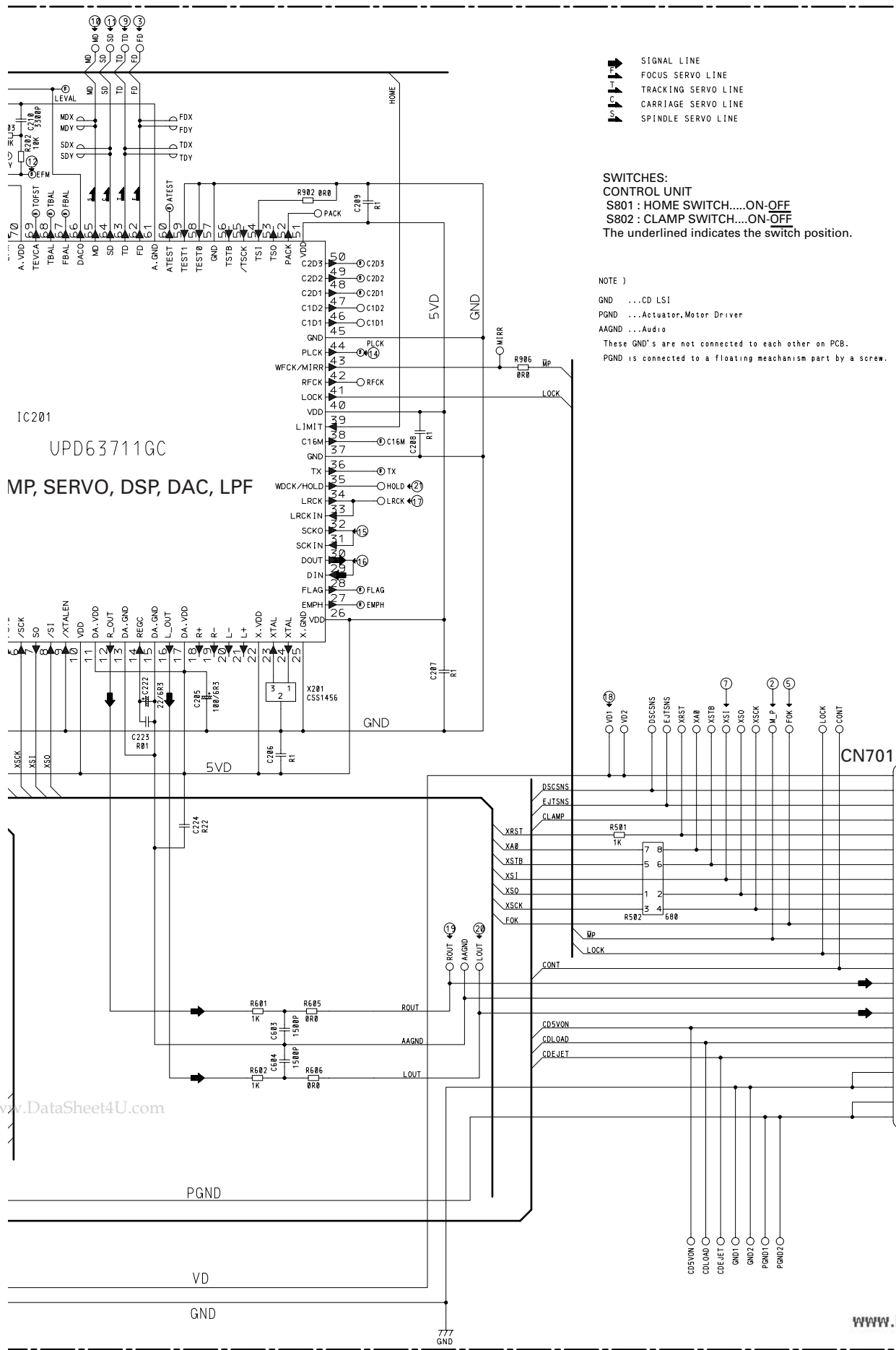

www.DataSheet4U.com

www.DataSheet4U.com

Note:1. The encircled numbers denote measuring pointes in the circuit diagram.
 2. Reference voltage
 REFO:2.5V

● Waveforms

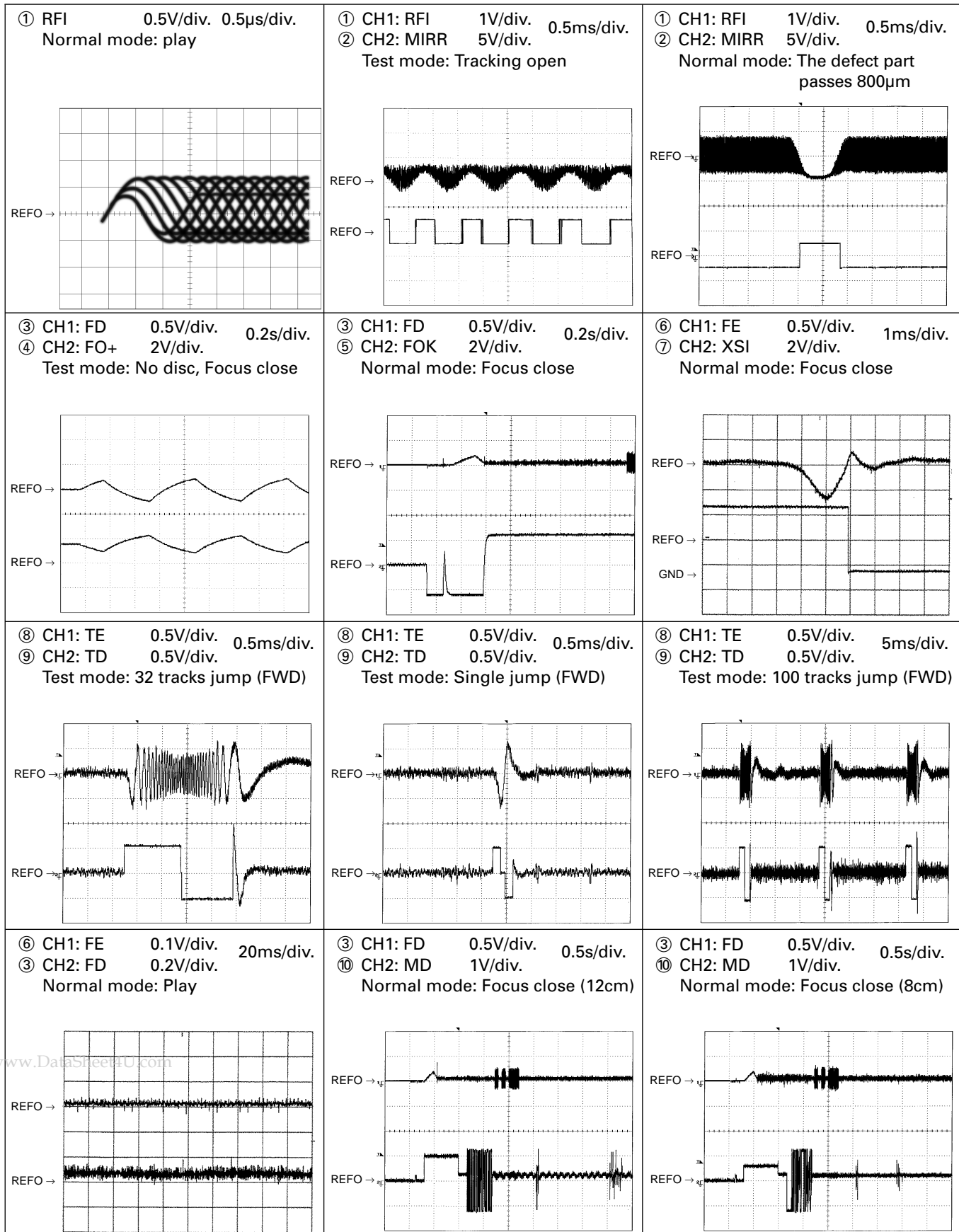

www.DataSheet4U.com

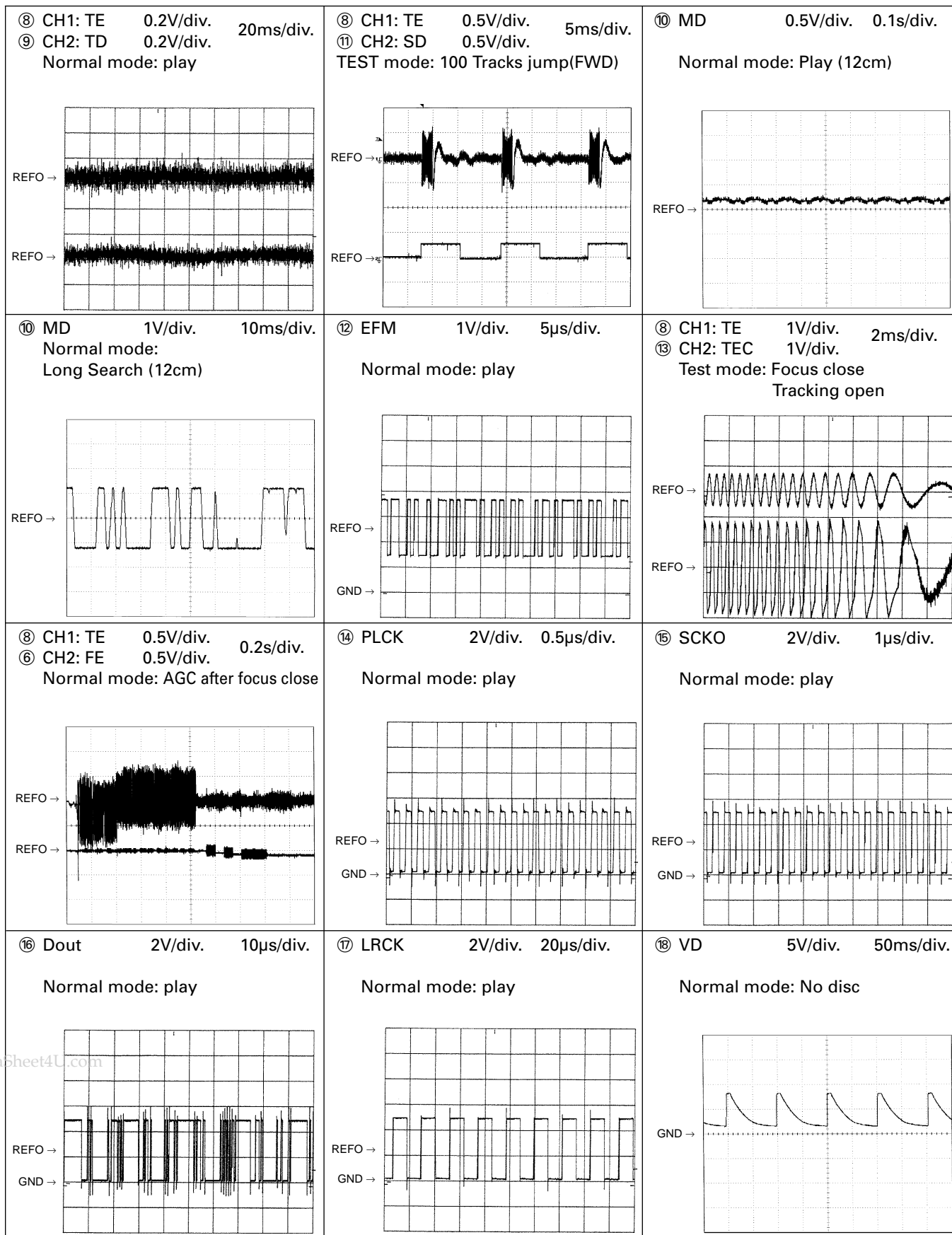

⑮ CH1: R OUT 1V/div. 0.2ms/div.
 ⑳ CH2: L OUT 1V/div.
 Normal mode: Play (1kHz 0dB)

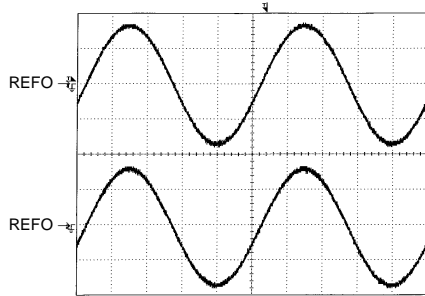

⑥ CH1: FE 0.2V/div. 1ms/div.
 ③ CH2: FD 0.5V/div.
 Normal mode: During AGC

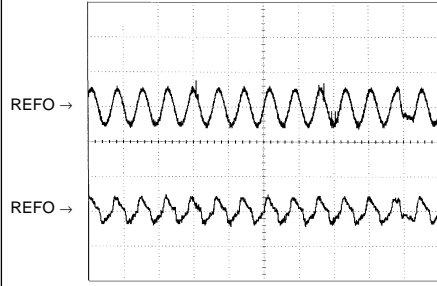

⑧ CH1: TE 0.2V/div. 1ms/div.
 ⑨ CH2: TD 0.5V/div.
 Normal mode: During AGC

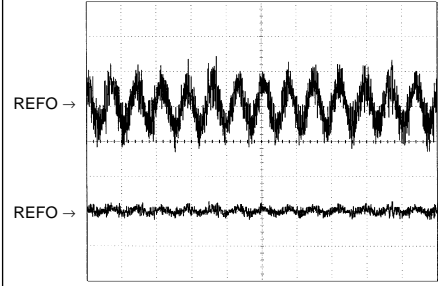

① CH1: RFI 1V/div. 0.5ms/div.
 ② CH2: HOLD 5V/div.
 Normal mode: The defect part passes
 800μm(B.D)

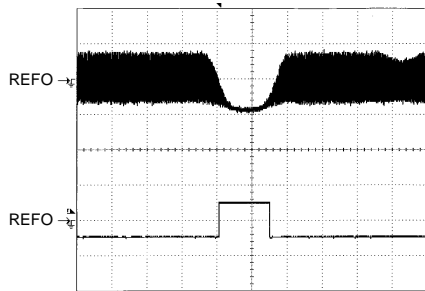

③ CH1: FD 0.5V/div. 0.5ms/div.
 ② CH2: HOLD 5V/div.
 Normal mode: The defect part passes
 800μm(B.D)

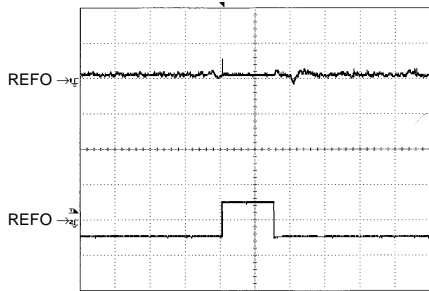

⑨ CH1: TD 0.1V/div. 0.5ms/div.
 ② CH2: HOLD 5V/div.
 Normal mode: The defect part passes
 800μm(B.D)

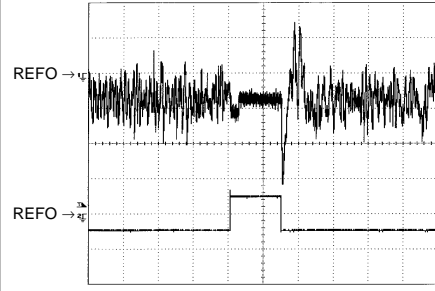

4. PCB CONNECTION DIAGRAM

A TUNER AMP ASSY

CORD ASSY

4.1 TUNER AMP ASSY

NOTE FOR PCB DIAGRAMS

1. The parts mounted on this PCB include all necessary parts for several destination. For further information for respective destinations, be sure to check with the schematic diagram.

2. Viewpoint of PCB diagrams

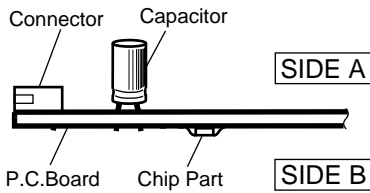

IC, Q

IC302

Q941

Q904

Q905

Q903

Q981

IC602

D CN701

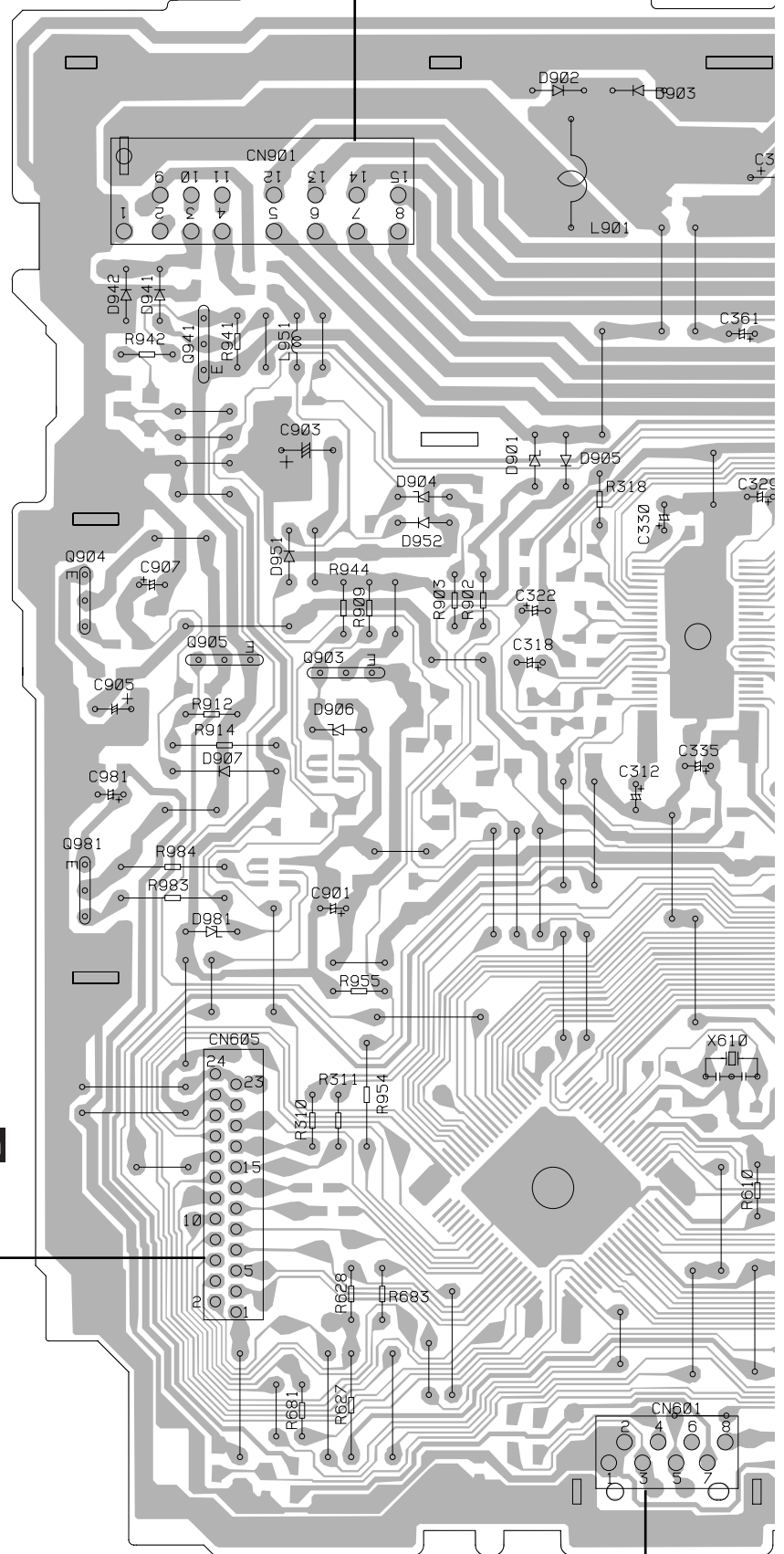

SIDE A

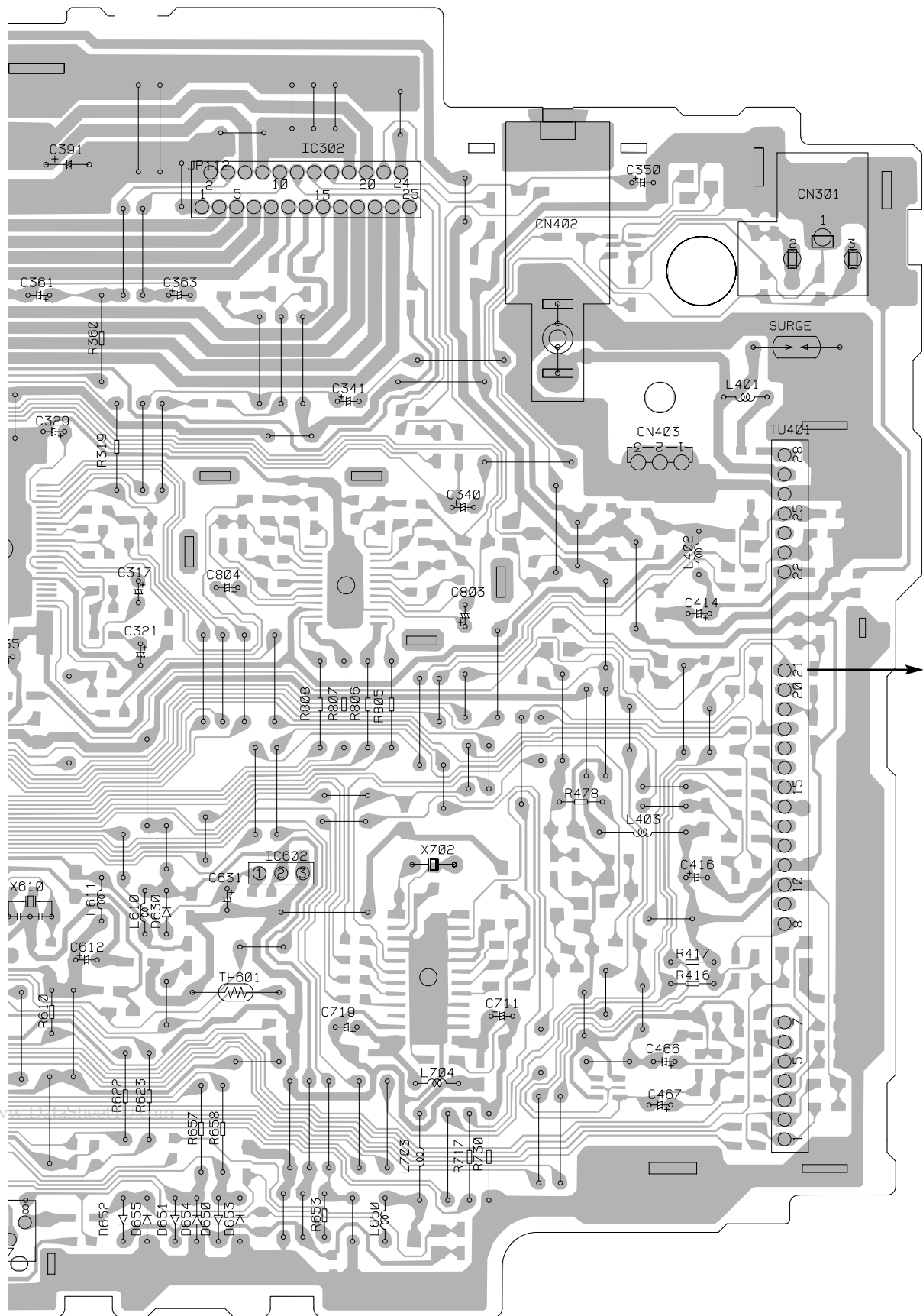

B

A

B

C

D

www.DataSheet4U.com

SIDE B

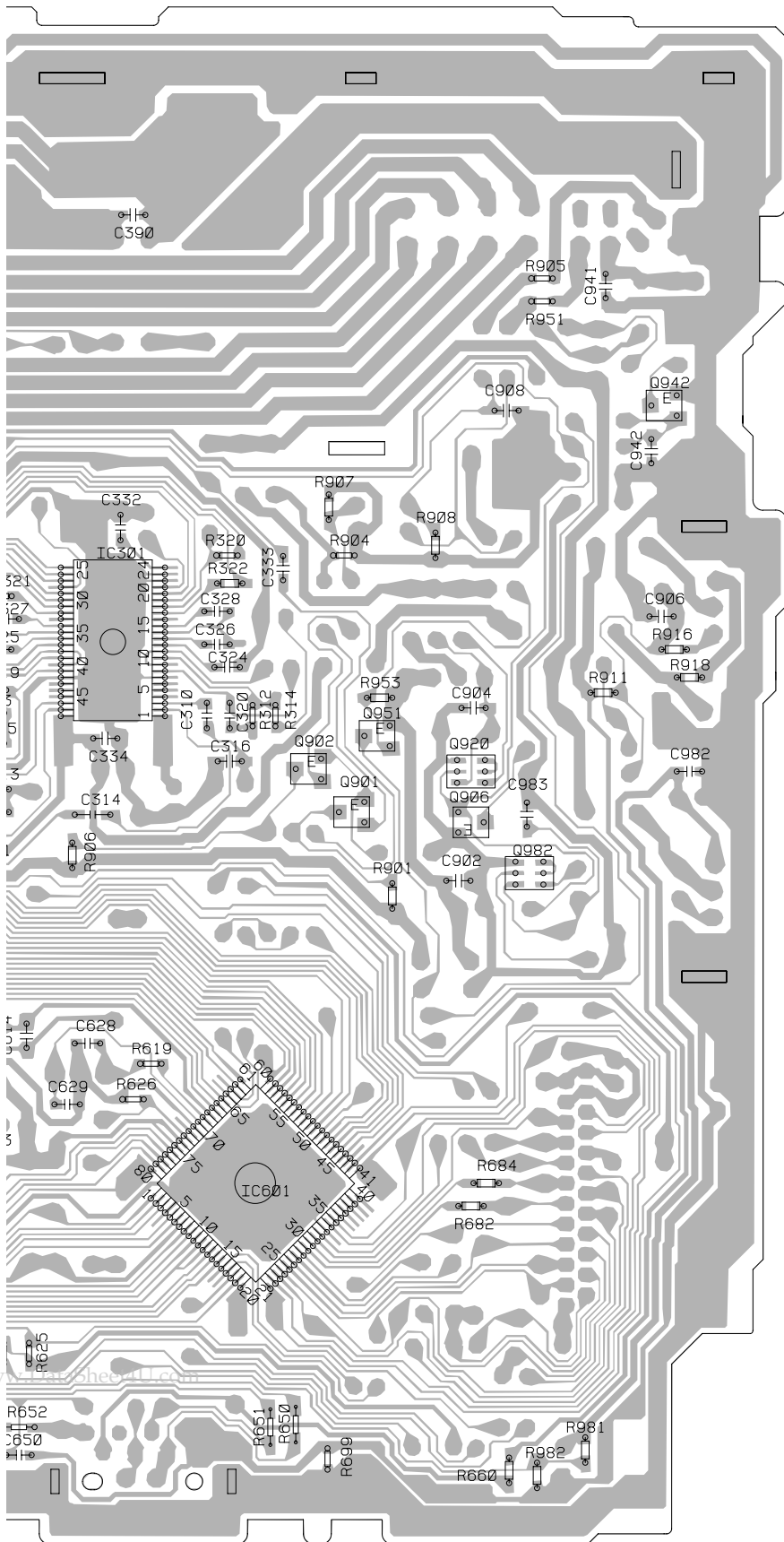

IC, Q

Q353

Q346

Q942

IC301

Q411 Q351

Q476 Q951

Q902 Q920

Q477

Q901

Q906

Q982

Q474

Q475

IC701

Q412

IC601

Q472

Q650

A

B

C

D

www.DataSheet4U.com

4.2 FM/AM TUNER UNIT

SIDE A

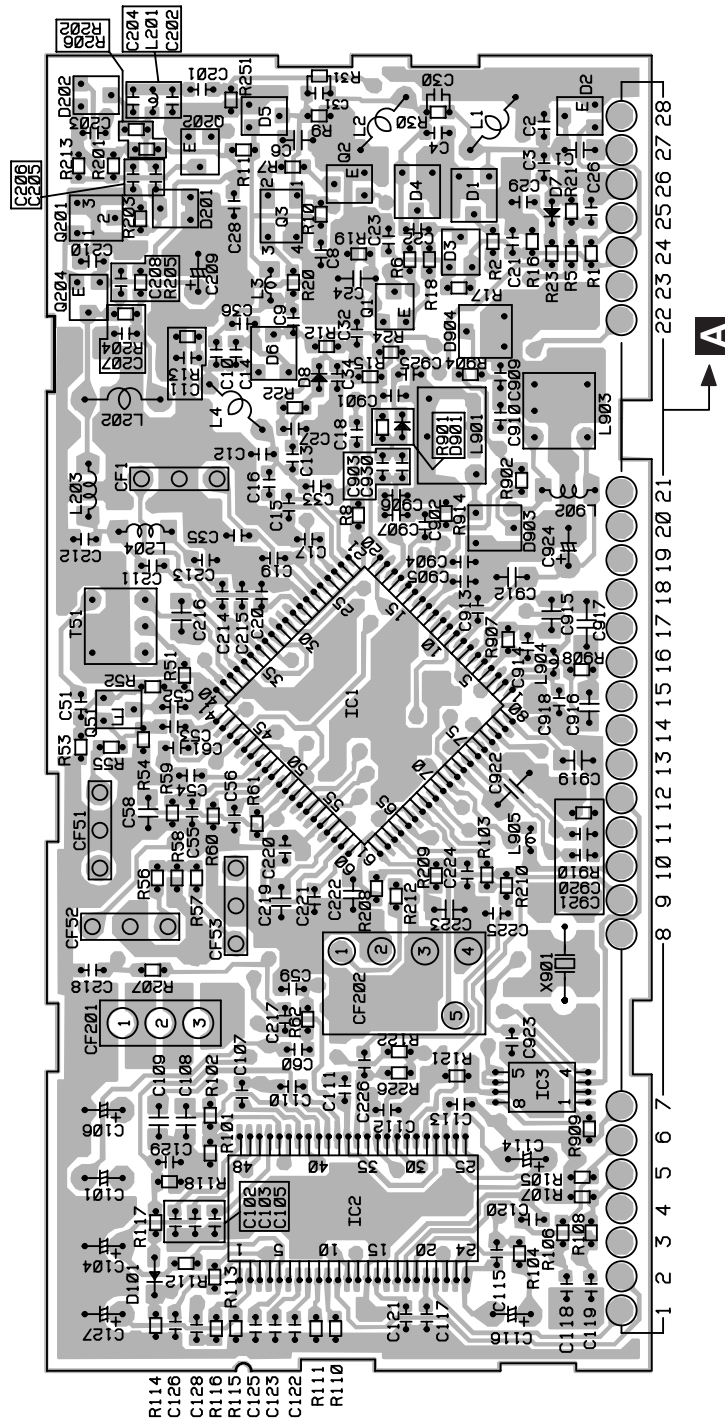

B FM/AM TUNER UNIT

www.DataSheet4U.com

SIDE B

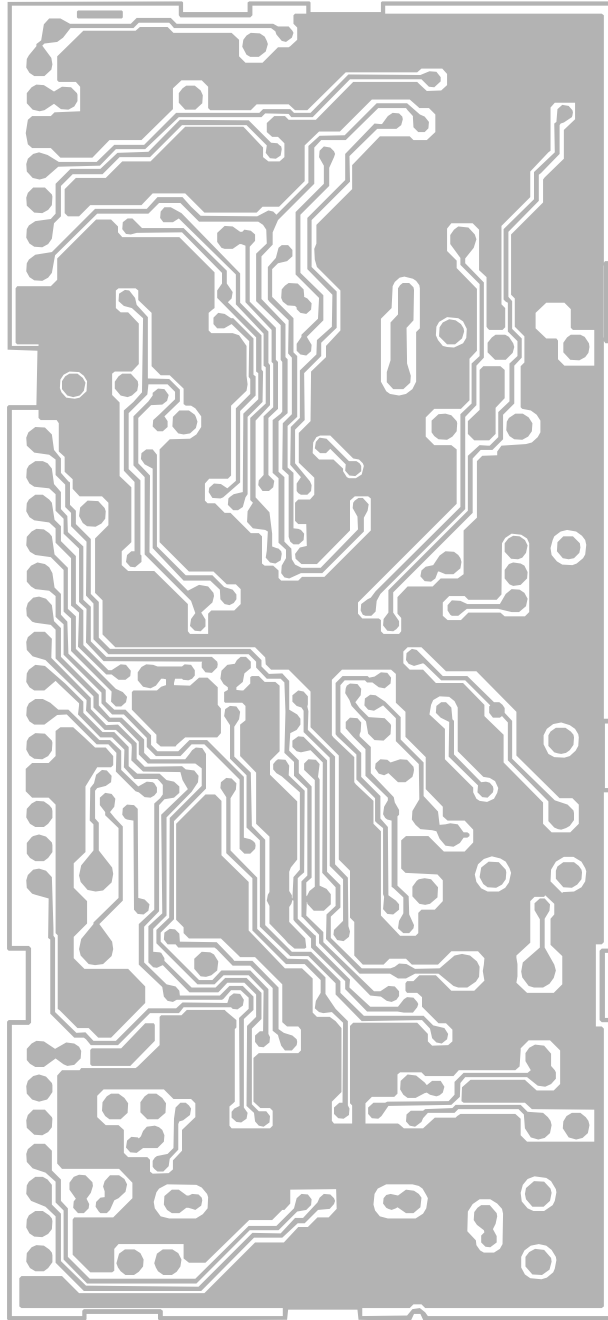

FM/AM TUNER UNIT

B

B

4.3 KEYBOARD UNIT

SIDE A

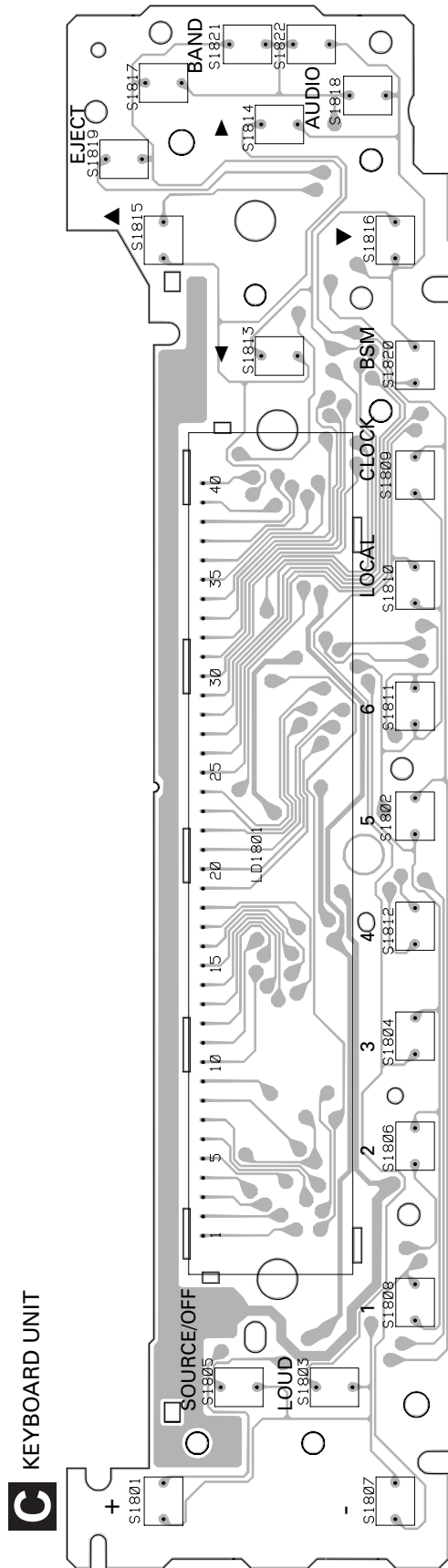

C KEYBOARD UNIT

A

B

C

D

SIDE B

A CN601

C KEYBOARD UNIT

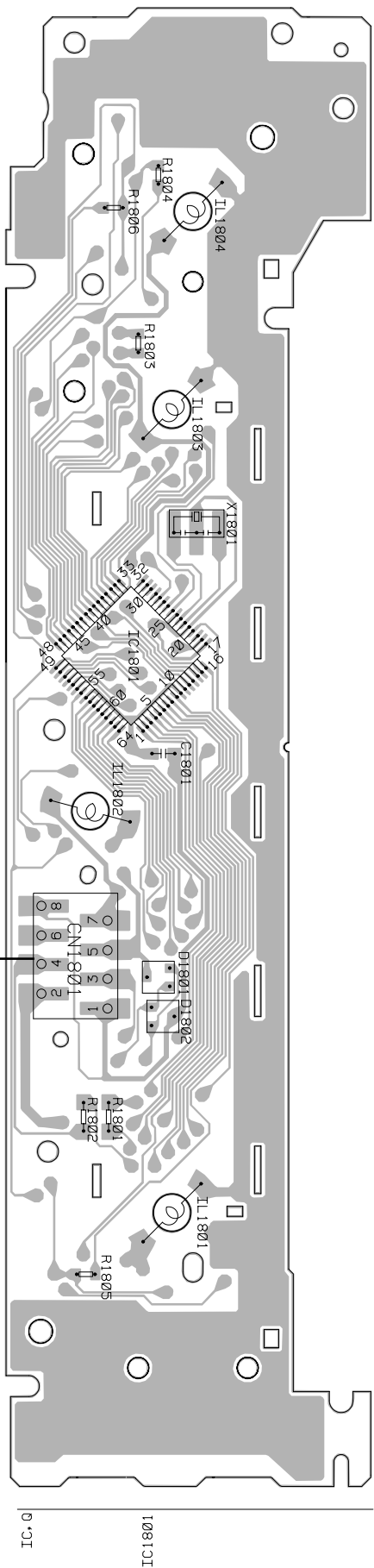

IC. d
IC1801
IC1802

4.4 CD MECHANISM MODULE

SIDE A

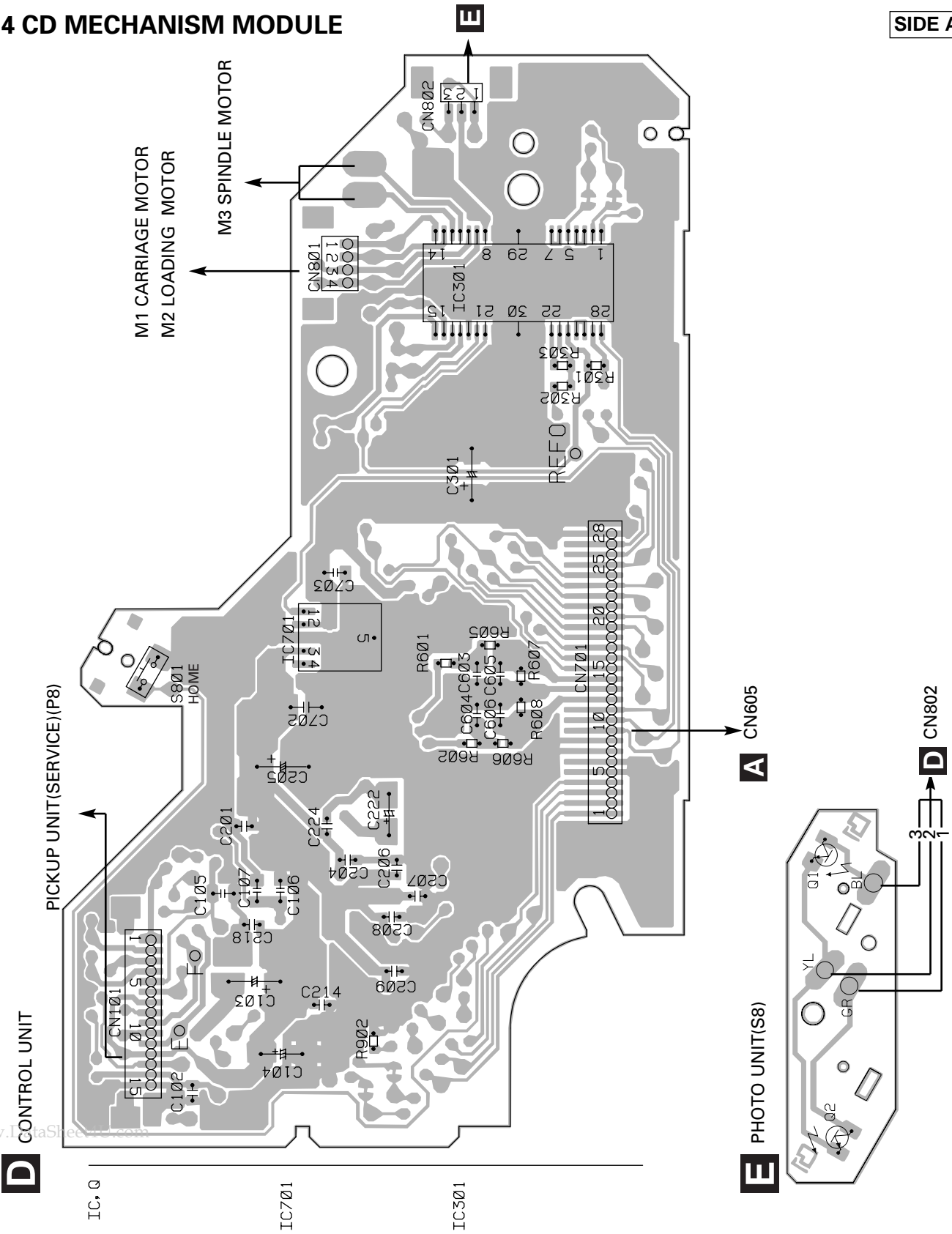

SIDE B

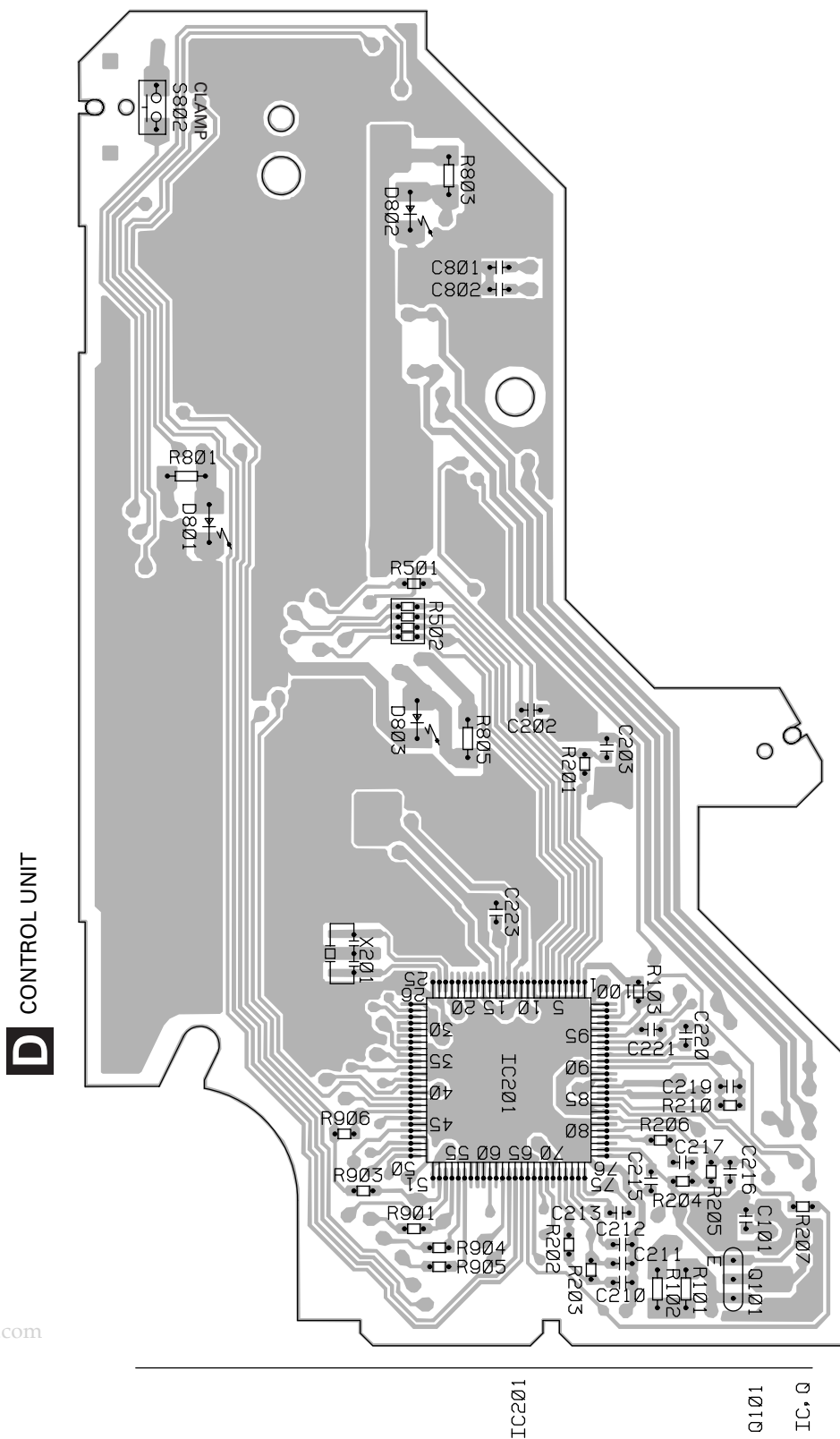

5. ELECTRICAL PARTS LIST

NOTES:

- Parts whose parts numbers are omitted are subject to being not supplied.
- The part numbers shown below indicate chip components.

Chip Resistor

RS1/OS○○○○J,RS1/○○S○○○○J

Chip Capacitor (except for CQS.....)

CKS....., CCS....., CSZS.....

====Circuit Symbol and No.====Part Name	Part No.	====Circuit Symbol and No.====Part Name	Part No.
A Unit Number : CWM6769		R 315	RS1/10S151J
Unit Name : Tuner Amp Assy		R 316	RS1/10S0R0J
		R 317	RS1/10S121J
		R 318	RD1/4PU104J
		R 319	RD1/4PU104J
MISCELLANEOUS			
IC 301 IC	SN761029DL	R 320	RS1/10S121J
IC 302 IC	TDA7384	R 321	RS1/10S101J
IC 601 IC	PE5091A	R 322	RS1/10S101J
IC 602 IC	S-80834ANY	R 342	RS1/8S821J
Q 346 Transistor	RN1610	R 343	RS1/8S821J
Q 351 Transistor	DTC114EK	R 344	RS1/10S223J
Q 353 Transistor	DTA124EK	R 345	RS1/10S223J
Q 411 Transistor	2SC2412K	R 352	RS1/10S103J
Q 650 Transistor	2SA1037K	R 353	RS1/10S103J
Q 901 Transistor	2SC2412K	R 354	RS1/10S331J
Q 902 Transistor	2SC2412K	R 360	RD1/4PU153J
Q 903 Transistor	2SD1859	R 411	RS1/10S681J
Q 904 Transistor	2SD2396	R 412	RS1/10S681J
Q 905 Transistor	2SB1243	R 413	RS1/10S681J
Q 906 Transistor	DTC114EK	R 414	RS1/10S103J
Q 941 Transistor	2SB1243	R 415	RS1/8S681J
Q 942 Transistor	DTC114EK	R 416	RD1/4PU473J
Q 981 Transistor	2SD2396	R 417	RD1/4PU472J
Q 982 Transistor	RN46A1	R 418	RS1/10S473J
D 901 Diode	HZS7L(C2)	R 419	RS1/10S473J
D 902 Diode	S5688G	R 420	RS1/10S473J
D 903 Diode	S5688G	R 421	RS1/10S473J
D 904 Diode	HZS7L(A1)	R 422	RS1/10S473J
D 905 Diode	S5688G	R 423	RS1/10S681J
D 906 Diode	HZS6L(B2)	R 424	RS1/10S681J
D 907 Diode	HZS9L(B3)	R 425	RS1/10S393J
D 941 Diode	S5688G	R 427	RS1/10S222J
D 942 Diode	S5688G	R 428	RS1/10S222J
D 981 Diode	HZS9L(B1)	R 460	RS1/10S272J
L 401 Ferri-Inductor	LAU4R7K	R 461	RS1/10S272J
L 402 Ferri-Inductor	LAU2R2K	R 464	RS1/10S162J
L 403 Inductor	LAU100K	R 465	RS1/10S162J
L 610 Ferri-Inductor	LAU101K	R 468	RS1/10S0R0J
L 611 Ferri-Inductor	LAU2R2K	R 469	RS1/10S0R0J
L 650 Ferri-Inductor	LAU2R2K	R 610	RD1/4PU822J
L 901 Choke Coil 600μH	CTH1221	R 611	RS1/10S433J
TH 601 Thermistor	CCX1031	R 614	RS1/8S0R0J
X 610 Crystal Resonator 4.194304MHz	CSS1023	R 619	RS1/10S682J
AR 946 Arrester	DSP-201M-S00B	R 620	RN1/10SE2202D
FM/AM Tuner Unit	CWE1501	R 622	RD1/4PU222J
RESISTORS		R 623	RD1/4PU222J
R 310	RD1/4PU222J	R 624	RS1/10S473J
R 311	RD1/4PU222J	R 625	RS1/10S473J
R 312	RS1/10S272J	R 626	RS1/10S473J
R 313	RS1/10S272J	R 627	RD1/4PU473J
R 314	RS1/10S151J	R 628	RD1/4PU222J
		R 629	RS1/10S473J
		R 630	RS1/10S822J
		R 649	RS1/8S222J
		R 650	RS1/8S222J

====Circuit Symbol and No.====Part Name	Part No.	====Circuit Symbol and No.====Part Name	Part No.
L 201 Inductor	LCTB330K1608	R 904	RS1/16S473J
L 202 Inductor	CTF1287	R 907	RS1/16S103J
L 203 Inductor	LCTA121J3225	R 908	RS1/16S681J
L 901 Coil	CTC1154	R 909	RS1/16S473J
L 902 Inductor	LCTA3R3J3225	R 914	RS1/16S562J
L 904 Inductor	LCTBR47K1608	CAPACITORS	
L 905 Inductor	LCTBR47K1608	C 1	CCSQCH4R0C50
T 51 Coil	CTE1132	C 6	CKSQYB105K10
CF 51 Ceramic Filter	CTF1442	C 8	CKSRYB222K50
CF 52 Ceramic Filter	CTF1442	C 10	CCSRCH220J50
CF 53 Ceramic Filter	CTF1442	C 11	CCSRCH150J50
CF 202 Ceramic Filter	CTF1348	C 12	CCSRCH8R0D50
X 901 Crystal Resonator 10.250MHz	CSS1432	C 14	CCSRCJ3R0C50
RESISTORS		C 15	CKSRYB103K50
R 1	RS1/16S183J	C 16	CKSRYB222K50
R 2	RS1/16S103J	C 17	CKSRYB222K50
R 5	RS1/16S0R0J	C 18	CCSRCJ3R0C50
R 7	RS1/16S273J	C 19	CKSRYB103K50
R 8	RS1/16S473J	C 20	CKSRYB103K50
R 9	RS1/16S223J	C 21	CKSRYB103K50
R 10	RS1/16S473J	C 24	CKSQYB334K16
R 11	RS1/16S221J	C 26	CKSRYB472K50
R 12	RS1/16S103J	C 30	CCSRCH220J50
R 13	RS1/16S104J	C 32	CCSRCH470J50
R 16	RS1/16S223J	C 35	CKSRYB103K50
R 17	RS1/16S221J	C 51	CKSRYB103K50
R 18	RS1/16S221J	C 52	CKSRYB473K16
R 19	RS1/16S473J	C 53	CCSRCK2R0C50
R 20	RS1/16S470J	C 54	CKSRYB103K50
R 31	RS1/16S0R0J	C 55	CKSRYB104K16
R 51	RS1/16S470J	C 56	CKSRYB104K16
R 52	RS1/16S103J	C 58	CKSQYB224K16
R 53	RS1/16S103J	C 101	CEALNP100M10
R 54	RS1/16S331J	C 102	CCSRCH151J50
R 55	RS1/16S331J	C 103	CKSRYB473K16
R 56	RS1/16S560J	C 105	CKSRYB682K25
R 57	RS1/16S560J	C 106	CEALR68M50
R 58	RS1/16S102J	C 107	CKSRYB103K50
R 59	RS1/16S225J	C 108	CKSQYB474K16
R 60	RS1/16S133J	C 109	CKSQYB474K16
R 61	RS1/16S433J	C 110	CKSRYB104K16
R 101	RS1/16S333J	C 111	CKSRYB104K16
R 102	RS1/16S103J	C 112	CKSRYB104K16
R 103	RS1/16S333J	C 113	CKSRYB123K25
R 104	RS1/16S562J	C 114	CEAL220M6R3
R 106	RS1/16S0R0J	C 115	CKSRYB473K16
R 108	RS1/16S0R0J	C 116	CEAL2R2M50
R 110	RS1/16S154J	C 117	CKSRYB102K50
R 111	RS1/16S273J	C 120	CKSRYB183K25
R 113	RS1/16S222J	C 121	CKSRYB332K50
R 114	RS1/16S333J	C 122	CKSRYB562K25
R 115	RS1/16S334J	C 123	CKSRYB681K50
R 116	RS1/16S473J	C 125	CKSRYB103K50
R 202	RS1/16S472J	C 126	CKSRYB103K50
R 203	RS1/16S225J	C 127	CEAL2R2M50
R 204	RS1/16S102J	C 128	CKSRYB103K50
R 205	RS1/16S220J	C 201	CCSRCH471J50
R 206	RS1/16S471J	C 202	CCSRCH100D50
R 208	RS1/16S104J	C 203	CKSRYB104K16
R 209	RS1/16S104J	C 204	CKSRYB332K50
R 210	RS1/16S563J	C 205	CKSRYB103K50
R 213	RS1/16S223J	C 206	CKSRYB104K16
R 251	RS1/16S225J	C 207	CKSRYB473K16
R 902	RS1/16S103J	C 208	CCSRCH560J50
		C 209	CEAL470M6R3
		C 210	CKSRYB103K50

www.DataSheet4U.com

====Circuit Symbol and No.====	Part Name	Part No.
C 211		CKSRYP103K50
C 212		CCSRCH101J50
C 215		CKSRYP223K25
C 216		CKSQYB334K16
C 217		CKSRYP103K50
C 219		CKSQYB105K10
C 220		CKSRYP104K16
C 221		CKSRYP473K16
C 222		CKSQYB334K16
C 223		CKSQYB474K16
C 224		CKSRYP104K16
C 225		CKSRYP272K50
C 226		CKSRYP682K25
C 902		CCSRCH270J50
C 904		CKSRYP223K25
C 905		CKSRYP103K50
C 906		CCSRTH100D50
C 907		CCSRTH150J50
C 909		CCSRTH100D50
C 910		CKSRYP332K50
C 912		CKSQYB474K16
C 913		CKSRYP223K25
C 914		CKSRYP682K25
C 915		CKSQYB223K25
C 916		CKSQYB474K16
C 917		CKSYB475K10
C 918		CKSRYP223K25
C 919		CKSQYB225K10
C 920		CCSRCH270J50
C 921		CCSRCH270J50
C 922		CKSYB105K16
C 923		CKSRYP103K50

C Unit Number : CWM6783(DEH-1100)
 : CWM6782(DEH-11)
 Unit Name : Keyboard Unit

MISCELLANEOUS

IC 1801	IC	PD6293A
X 1801	Ceramic Resonator 4.97MHz	CSS1422
IL 1801	Lamp 14V 40mA(DEH-1100)	CEL1547
IL 1801	Lamp 14V 40mA(DEH-11)	CEL1638
IL 1802	Lamp 14V 40mA(DEH-1100)	CEL1547
IL 1802	Lamp 14V 40mA(DEH-11)	CEL1638
IL 1803	Lamp 14V 40mA(DEH-1100)	CEL1547
IL 1803	Lamp 14V 40mA(DEH-11)	CEL1638
IL 1804	Lamp 14V 40mA(DEH-1100)	CEL1547
IL 1804	Lamp 14V 40mA(DEH-11)	CEL1638
LCD1801	LCD	CAW1560

RESISTORS

R 1801	RS1/8S222J
R 1802	RS1/8S222J
R 1803	RS1/10S471J
R 1804	RS1/10S471J
R 1805	RS1/10S471J
R 1806	RS1/10S471J

CAPACITORS

C 1801	CKSQYB103K25
--------	--------------

====Circuit Symbol and No.====	Part Name	Part No.
--------------------------------	-----------	----------

D Unit Number : CWX2411
 Unit Name : Control Unit

MISCELLANEOUS

IC 201	IC	UPD63711GC
IC 301	IC	BA5985FM
IC 701	IC	BA05SFP
Q 101	Transistor	2SB1132
D 801	LED	CL200IRX
D 802	LED	CL200IRX
X 201	Ceramic Oscillator 16.934MHz	CSS1456
S 801	Spring Switch(HOME)	CSN1051
S 802	Spring Switch(CLAMP)	CSN1052

RESISTORS

R 101	RS1/8S120J
R 102	RS1/8S100J
R 103	RS1/16S222J
R 201	RS1/16S104J
R 202	RS1/16S103J
R 203	RS1/16S393J
R 204	RS1/16S103J
R 205	RS1/16S103J
R 206	RS1/16S182J
R 207	RS1/16S123J
R 302	RS1/16S153J
R 303	RS1/16S103J
R 501	RS1/16S102J
R 502	RA4C681J
R 601	RS1/16S102J
R 602	RS1/16S102J
R 605	RS1/16S0R0J
R 606	RS1/16S0R0J
R 801	RS1/8S751J
R 803	RS1/8S751J
R 902	RS1/16S0R0J
R 906	RS1/16S0R0J

CAPACITORS

C 101	CCSRCH102J25
C 102	CKSRYP104K16
C 103	CEV101M6R3
C 104	CEV470M6R3
C 105	CKSQYB334K16
C 106	CKSQYB334K16
C 107	CKSQYB334K16
C 201	CKSRYP104K16
C 202	CKSRYP471K50
C 203	CKSRYP104K16
C 205	CEV101M6R3
C 206	CKSRYP104K16
C 207	CKSRYP104K16
C 208	CKSRYP104K16
C 209	CKSRYP104K16
C 210	CKSRYP332K50
C 211	CKSRYP104K16
C 212	CKSRYP104K16
C 213	CKSRYP392K50
C 214	CKSRYP104K16
C 215	CKSRYP104K16
C 216	CCSRCJ3R0C50
C 217	CCSRCH270J50
C 218	CKSRYP104K16
C 219	CCSRCH181J50

====Circuit Symbol and No.====	Part Name	Part No.
C 220		CCSRCH510J50
C 221		CKSRYB682K25
C 222		CEV220M6R3
C 223		CKSRYB103K25
C 224		CKSRYB224K10
C 301		CEV101M10
C 603		CCSOSL152J50
C 604		CCSOSL152J50
C 702	10μF/10V	CCH1349
C 703		CKSQYB334K16

E Unit Number :
 Unit Name : Photo Unit(S8)

Q	1	Photo-transistor	CPT230SX-TU
Q	2	Photo-transistor	CPT230SX-TU

Miscellaneous Parts List

M	1	Pickup Unit(Service)(P8)	CXX1285
M	1	Motor Unit(CARRIAGE)	CXB2190
M	2	Motor Unit(LOADING)	CXB2195
M	3	Motor Unit(SPINDLE)	CXB2562
		Fuse(10A)	CEK1136

6. ADJUSTMENT

6.1 CD ADJUSTMENT

1) Precautions

- This unit uses a single power supply (+5V) for the regulator. The signal reference potential, therefore, is connected to REFO(approx. 2.5V) instead of GND.

If REFO and GND are connected to each other by mistake during adjustments, not only will it be impossible to measure the potential correctly, but the servo will malfunction and a severe shock will be applied to the pick-up. To avoid this, take special note of the following.

Do not connect the negative probe of the measuring equipment to REFO and GND together. It is especially important not to connect the channel 1 negative probe of the oscilloscope to REFO with the channel 2 negative probe connected to GND.

Since the frame of the measuring instrument is usually at the same potential as the negative probe, change the frame of the measuring instrument to floating status.

If by accident REFO comes in contact with GND, immediately switch the regulator or power OFF.

- Always make sure the regulator is OFF when connecting and disconnecting the various filters and wiring required for measurements.
- Before proceeding to further adjustments and measurements after switching regulator ON, let the player run for about one minute to allow the circuits to stabilize.
- Since the protective systems in the unit's software are rendered inoperative in test mode, be very careful to avoid mechanical and /or electrical shocks to the system when making adjustment.
- Disc detection during loading and eject operations is performed by means of a photo transistor in this unit. Consequently, if the inside of the unit is exposed to a strong light source when the outer casing is removed for repairs or adjustment, the following malfunctions may occur.
 - *During PLAY, even if the eject button is pressed, the disc will not be ejected and the unit will remain in the PLAY mode.
 - *The unit will not load a disc.

When the unit malfunctions this way, either re-position the light source, move the unit or cover the photo transistor.

2) Test Mode

This mode is used for adjusting the CD mechanism module of the device.

- Test mode starting procedure
Reset while pressing the **4** and **6** keys together.
- Test mode cancellation
Switch ACC, back-up OFF.
- After pressing the EJECT key, do not press any other key until the disk is completely ejected.
- If the ► or ◀ key is pressed while focus search is in progress, immediately turn the power off (otherwise the actuator may be damaged due to adhesion of the lenses).
- Jump operation of TRs other than 100TR continues after releasing the key. CRG move and 100TR jump operations are brought into the "Tracking close" status when the key is released.
- Powering Off/On resets the jump mode to "1TR", and the automatic adjustment value to the initial value.

● Flow Chart

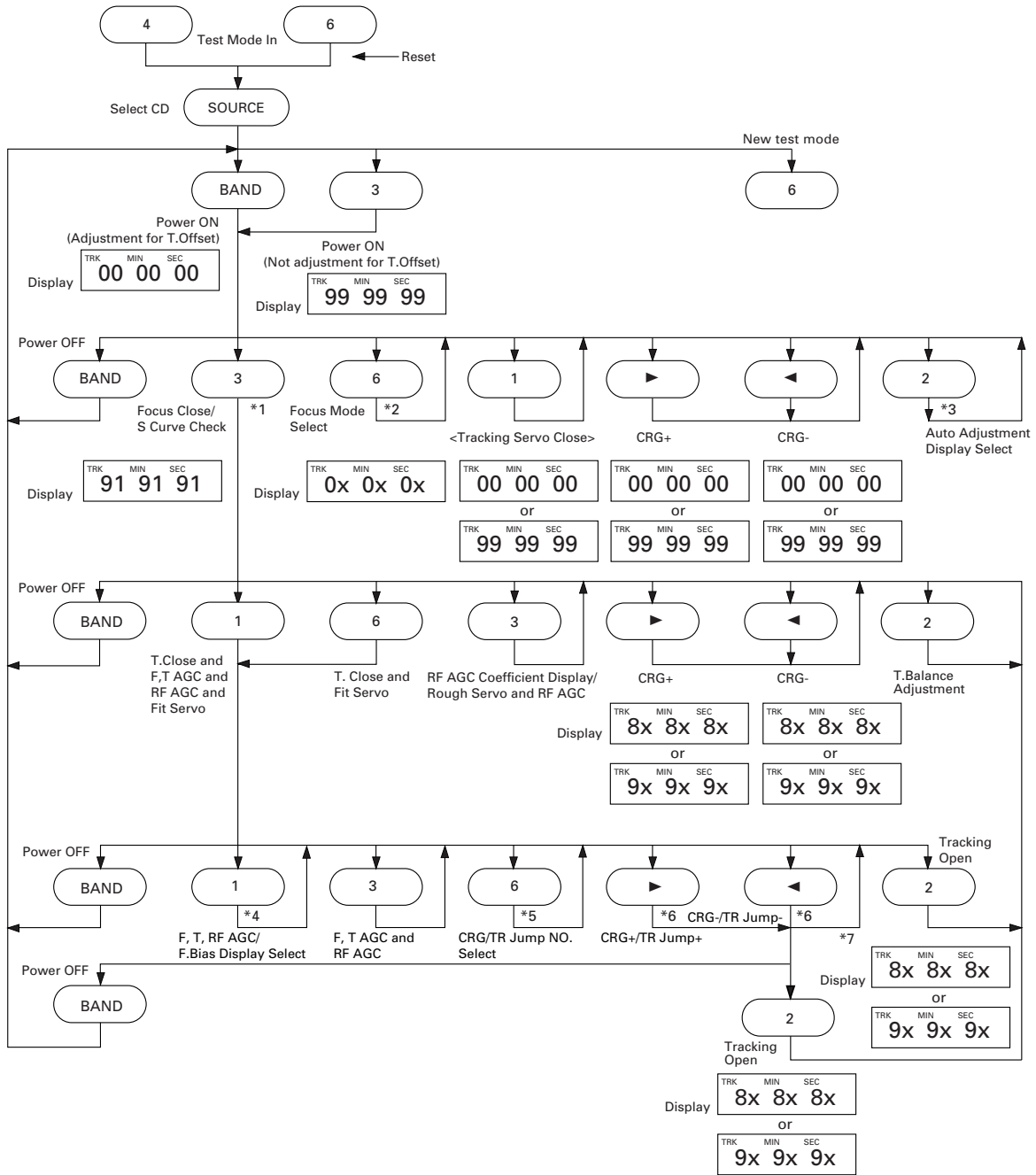

*1 "00", "99"→Focus Close / "01"→S.Curve

*6 1TR/4TR/10TR/32TR/100TR

*2 → Focus Close (00(99)) → S.Curve (01) → LD Off (02)

*7 CRG Move, 100TR Jump

www.DataSheet4U.com

*3 → F.Cancel → T.Offset → The original display

*4 → TRK, MIN, SEC → F.AGC Gain → T.AGC Gain → F.Bias

*5 → 1TR (91(81)) → 4TR (92(82)) → 10TR (93(83)) → 32TR (94(84)) → 100TR (95(85)) → CRG Move (96(86))

6.2 CHECKING THE GRATING AFTER CHANGING THE PICKUP UNIT

• Note :

The grating angle of the PU unit cannot be adjusted after the PU unit is changed. The PU unit in the CD mechanism module is adjusted on the production line to match the CD mechanism module and is thus the best adjusted PU unit for the CD mechanism module. Changing the PU unit is thus best considered as a last resort. However, if the PU unit must be changed, the grating should be checked using the procedure below.

• Purpose :

To check that the grating is within an acceptable range when the PU unit is changed.

• Symptoms of Mal-adjustment :

If the grating is off by a large amount symptoms such as being unable to close tracking, being unable to perform track search operations, or taking a long time for track searching.

• Method :

- | | |
|-----------------------|----------------------------|
| • Measuring Equipment | • Oscilloscope, Two L.P.F. |
| • Measuring Points | • E, F, REFOUT |
| • Disc | • ABEX TCD-784 |
| • Mode | • TEST MODE |

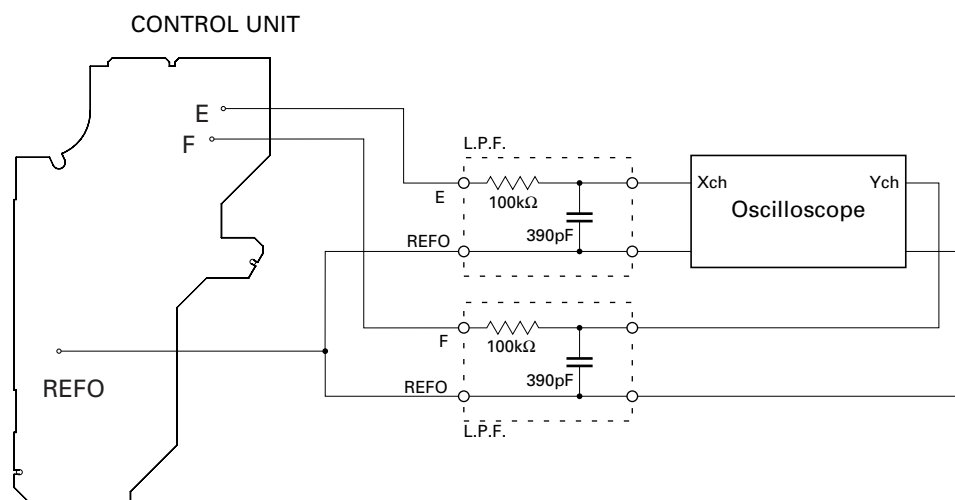

• Checking Procedure

1. In test mode, load the disc and switch the 5V regulator on.
2. Using the ► and ◀ buttons, move the PU unit to the innermost track.
3. Press key **3** to close focus, the display should read "91". Press key **2** to implement the tracking balance adjustment the display should now read "81". Press key **3** 2 times. The display will change, returning to "81" on the fourth press.
4. As shown in the diagram above, monitor the LPF outputs using the oscilloscope and check that the phase difference is within 75°. Refer to the photographs supplied to determine the phase angle.
5. If the phase difference is determined to be greater than 75° try changing the PU unit to see if there is any improvement. If, after trying this a number of times, the grating angle does not become less than 75° then the mechanism should be judged to be at fault.

• Note

Because of eccentricity in the disc and a slight misalignment of the clamping center the grating waveform may be seen to "wobble" (the phase difference changes as the disc rotates). The angle specified above indicates the average angle.

• Hint

Reloading the disc changes the clamp position and may decrease the "wobble".

Grating waveform

Ech → Xch 20mV/div, AC

Fch → Ych 20mV/div, AC

0°

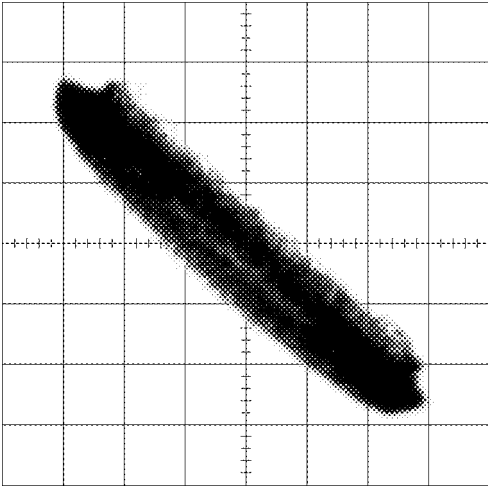

30°

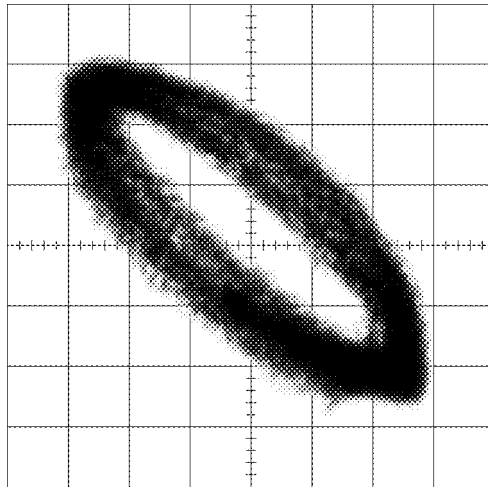

45°

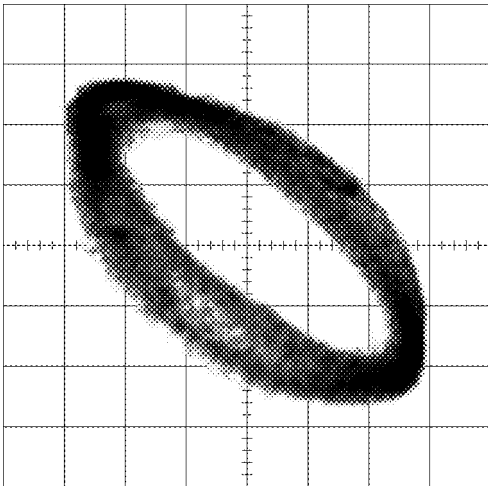

60°

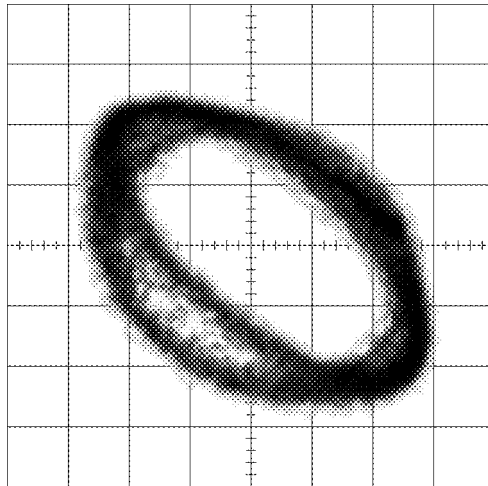

75°

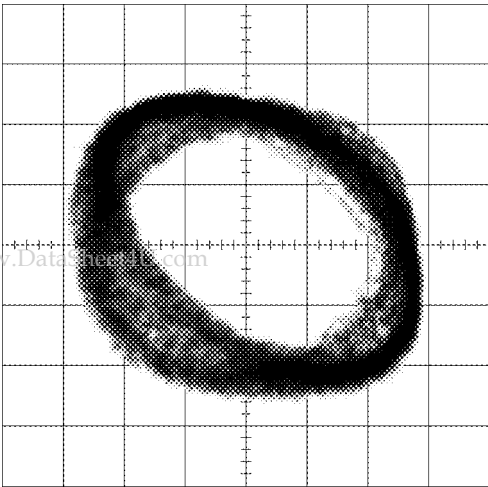

90°

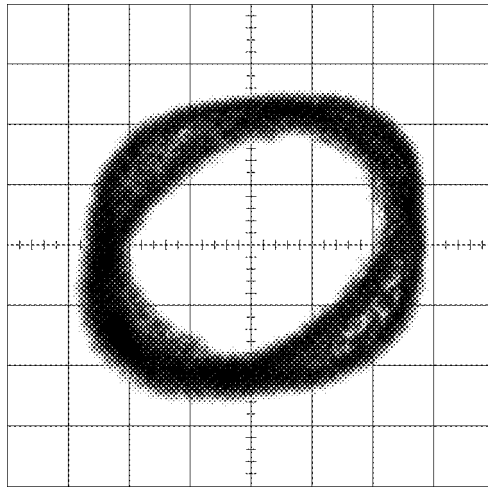

7. GENERAL INFORMATION

7.1 DIAGNOSIS

7.1.1 TEST MODE

● Error Messages

If a CD is not operative or stopped during operation due to an error, the error mode is turned on and cause(s) of the error is indicated with a corresponding number. This arrangement is intended at reducing nonsense calls from the users and also for facilitating trouble analysis and repair work in servicing.

(1) Basic Indication Method

1) When SERRORM is selected for the CSMOD (CD mode area for the system), error codes are written to DMIN (minutes display area) and DSEC (seconds display area). The same data is written to DMIN and DSEC. DTNO remains in blank as before.

2) Head unit display examples

Depending on display capability of LCD used, display will vary as shown below. xx contains the error number.

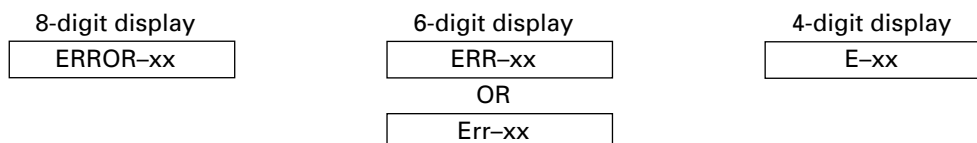

(2) Error Code List

Code	Class	Displayed error code	Description of the code and potential cause(s)
10	Electricity	Carriage Home NG	CRG can't be moved to inner diameter. CRG can't be moved from inner diameter. → Failure on home switch or CRG move mechanism.
11	Electricity	Focus Servo NG	Focusing not available. → Stains on rear side of disc or excessive vibrations on REWRITABLE.
12	Electricity	Spindle Lock NG	Spindle not locked. Sub-code is strange (not readable). → Failure on spindle, stains or damages on disc, or excessive vibrations.
		Subcode NG	A disc not containing CD-R data is found. Turned over disc are found, though rarely.
		RF AMP NG	→ Failure on home switch or CRG move mechanism. An appropriate RF AMP gain can't be determined. → CD signal error.
17	Electricity	Setup NG	APC protection doesn't work. Focus can be easily lost. → Damages or stains on disc, or excessive vibrations.
30	Electricity	Search Time Out	Failed to reach target address. → CRG tracking error or damages on disc.
A0	System	Power Supply NG	Power (VD) is ground faulted. → Failure on SW transistor or power supply (failure on connector).

Remarks: Mechanical errors are not displayed (because a CD is turned off in these errors).

Unreadable TOC does not constitute an error. An intended operation continues in this case.

A newly designed head unit must conform to the example given above.

Upper digits of an error code are subdivided as shown below:

1x: Setup relevant errors, 3x: Search relevant errors, 3x: Search relevant errors, Ax: Other errors.

● New Test Mode

S-CD plays the same way as before.

If an error such as off focus, spindle unlocking, unreadable sub-code, or sound skipping occurs after setup, its cause and time occurred (in absolute time) are displayed.

During setup, operational status of the control software (internal RAM: CPOINT) is displayed.

These displays and functions are prepared for enhancing aging in the servicing and efficiency of trouble analysis.

(1) Shifting to the New Test Mode

- ① Turn on the current test mode by starting the reset from the key.
- ② Select S-CD for the source through the specified procedure including use of the [SOURCE] key, and inserting the disc. Then, press the [Jump Mode Selector] key while maintaining the regulator turned off.
- ③ After the above operations, the new test mode remains on irrespective of whether the S-CD is turned on or off.
You can reset the new test mode by turning on the reset start.

* With some products, the new test mode can be reset through the same operations as that employed for shifting to the STBY mode (while maintaining the Acc turned off).

(2) Key Correspondence

Key (Example)	Test mode		New test mode	
	Power Off	Power On	In-play	Error Production
BAND	To power on (offset adjustment performed)	To power off	–	Time/Err.No. switching
▶	–	FWD-Kick	FF/TR+	–
◀	–	REV-Kick	REV/TR-	–
1	–	T.Close (AGC performed) /parameter display switching	Scan	–
2	–	T.BAL adjustment /T.Open	Mode	–
3	To power on (offset adjustment not performed)	F.Close/RF AGC/AGC	–	–
6	–	Mode switching /T.Close (no AGC)/Jump switching	Auto/Manu	–

Note: Eject and CD on/off is performed in the same procedure as that for the normal mode.

(3) Cause of Error and Error Code

Code	Class	Contents	Description and cause
40	Electricity	Off focus detected.	FOK goes low. → Damages/stains on disc, vibrations or failure on servo.
41	Electricity	Spindle unlocked.	FOK = Low continued for 50 msec. → Damages/stains on disc, vibrations or failure on servo.
42	Electricity	Sub-code unreadable.	Sub-code was unreadable for 50 msec. → Damages/stains on disc, vibrations or failure on servo.
43	Electricity	Sound skipping detected.	Last address memory function was activated. → Damages/stains on disc, vibrations or failure on servo.

Note: Mechanical errors during aging are not displayed.

The error codes should be indicated in the same way as in the normal mode.

(4) Display of Operational Status (CPOINT) during Setup

Status No.	Contents	Protective action
01	Carriage move to home position started.	None
02	Carriage is moving toward inner diameter.	Specified 10 seconds has been passed or failure on home switch.
03	Carriage is moving toward outer diameter.	Specified 10 seconds has been passed or failure on home switch.
05	Carriage outer diameter feed (1 second) in progress.	None
11	Setup started.	None
12	Spindle rotation and focus search started.	None
13	Waiting for focus close (XSI=Low).	Specified focus search time has been passed.
14	Waiting for focus close (FOK=High). (After AGC)	Specified focus search time has been passed.
15	Waiting for focus close (FOK=High). (Before AGC)	Specified focus search time has been passed.
16	Rough AGC in progress.	Off focus.
17	Setup (1/2) before T balance adjustment is started.	Off focus.
18	Setup (2/2) before T balance adjustment is started.	Off focus.
24	T balance adjustment (1/2).	Off focus.
25	T balance adjustment (2/2).	Off focus.
26	Standing by after spindle rough servo is over.	Off focus.
27	Setup before RF AGC (first) is started.	Off focus.
28	RF AGC (first) in progress.	Off focus.
29	Setup before RF AGC (second) is started.	Off focus.
30	RF AGC (second) in progress.	Off focus.
31	Tracking close in progress.	Off focus.
32	Standing by after tracking is closed.	Off focus.
33	Focus AGC started.	Off focus.
34	Focus AGC in progress. Tracking AGC started.	Off focus.
35	Tracking AGC in progress. Spindle processes applicable servo.	Off focus.
36	Check of MIRR and LOCK pin. RF AGC in progress. CRG close in progress. Check of sub-code.	Off focus. Spindle not locked. Sub-code unreadable.

(5) Display Examples

1) During Setup (When status no. = 11)

TRK No.	MIN.	SEC.
11	11'	11"

2) During Operation (TOC read, TRK search, Play, FF and REV)

The same as in the normal mode.

3) When a Protection Error Occurred

Switch to the following displays (A) and (B) using the [BAND] switch:

(A) Error occurrence timing display in absolute time.

An example: Error occurred in 12th tune at 34'56" in absolute time.

www.DataSheet4U.com

TRK No.	MIN.	SEC.
12	34'	56"

(B) Error No. display

An example: Error #40 (Off focus is detected)

ERROR-40

7.1.2 DISASSEMBLY

● **Removing the Upper Case (not shown)**

● **Removing the CD Mechanism Module (Fig.1)**

1 Remove the four screws.

Disconnect the connector and then remove the CD Mechanism Module (not shown).

● **Removing the Grille Assy (not shown)**

1. Disconnect the two stoppers and then remove the Grille Assy.

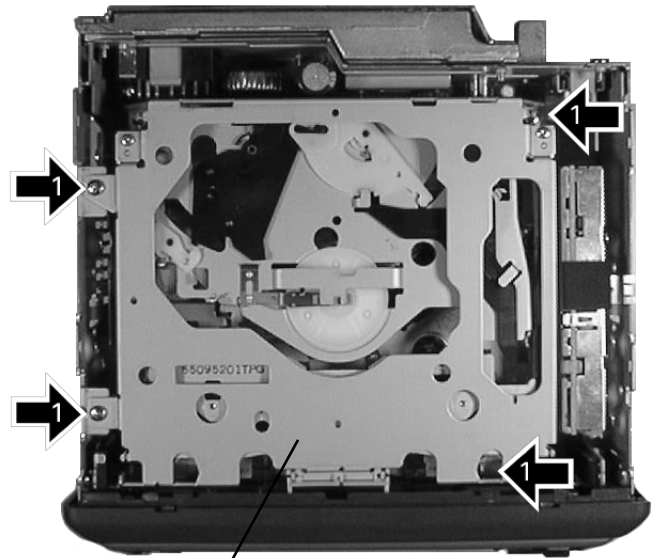

CD Mechanism Module

Fig.1

● **Removing the Tuner Amp Assy**

1 Remove the two screws (Fig.2).

2 Remove the three screws and then remove the Cover (Fig.2).

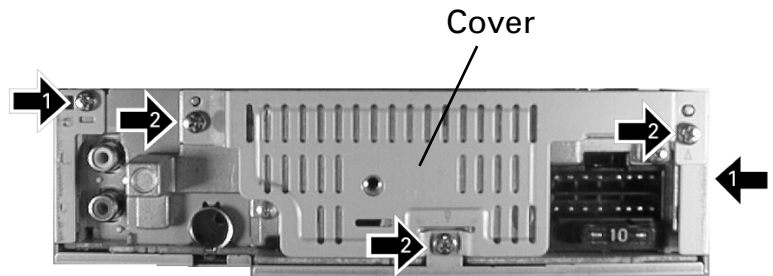
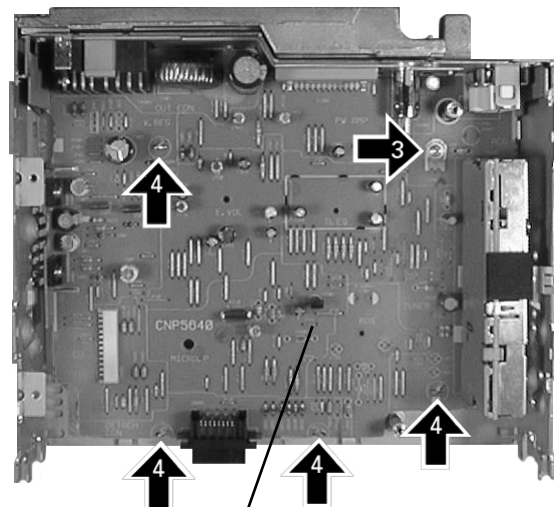

Fig.2

3 Remove the screw (Fig.3).

4 Disconnect the four claws and then remove the Tuner Amp Assy (Fig.3).



Tuner Amp Assy

Fig.3

● Removing the Upper Frame

1. Remove six Springs A, two Springs B and four Screws.
2. Remove two Tabs situated on rear side of the Upper Frame, remove two Arms on the front side, then remove two Tabs on the front side.

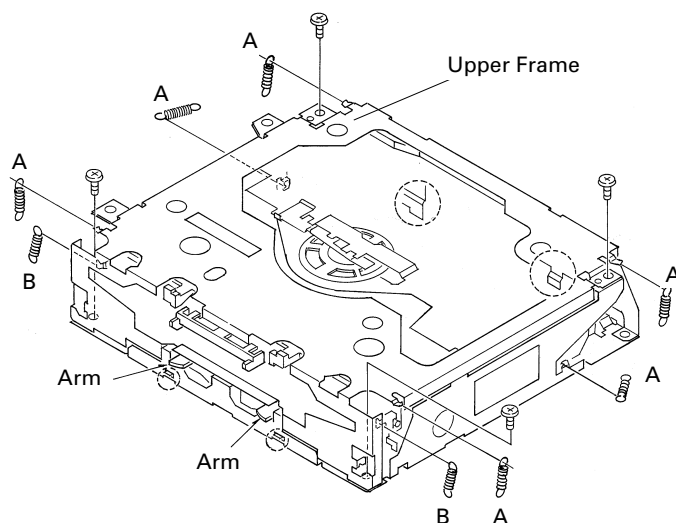

● Removing the Carriage Mechanism

1. Disengage the Carriage Mechanism from the two dampers situated in the front side by driving it up, then disengage and remove the mechanism from the one damper by driving it up aslant into front side direction.

Note : When assembling the Carriage Mechanism, coat the dampers with alcohol prior to the assembly.

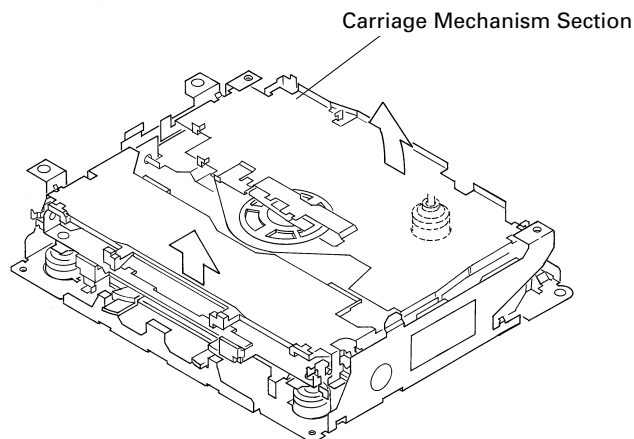

● Removing the Clamp Arm Assy

1. Remove a Spring A, a B and a Spring C.
2. Drive the Clamp Arm Assy up into rear side direction, then disengage the arm from its current position. Finally, drive the assembly approximately 45 degrees upward, then slide the assembly toward right side to remove it.

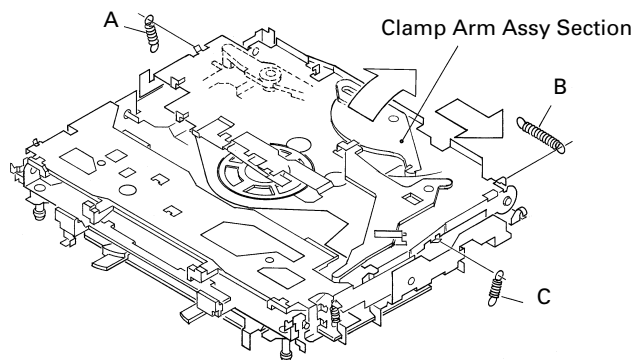

● **Removing the Guide Arm Assy**

1. Remove a connector, a spring A and B
2. Drive the Guide Arm Assy up aslant into rear side direction, then remove it from a Pin. Finally, drive the assembly approximately 45 degrees upward, then slide the assembly toward left side to remove it.

Note : When assembling the guide arm assembly, route the cord inside the assembly. In this operation, care must be exercised so that cord may be caught by the gear.

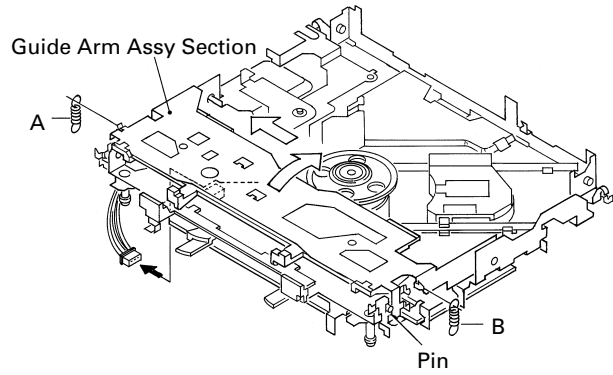

● **Removing the LO Arm Assy**

1. Remove two Pins to dismount the LO Arm Assy.

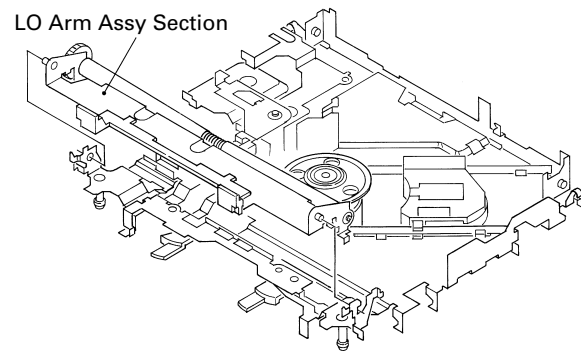

● **Removing the Control Unit and the Spindle Motor**

1. Remove from the connector after mounting the short pin on the flexible PCB of the pickup unit.
2. Remove two Soldered joints, then remove two Screws A.
3. Remove two connectors and a Screw B.
4. Disengage the Control Unit from two Tabs, then dismount the unit by sliding it toward left.
5. Dismount the Spindle Motor.

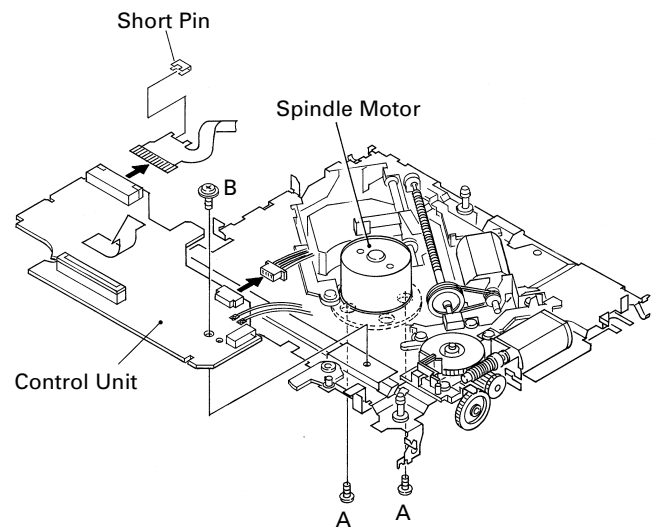

● Removing the Loading Motor and Carriage Motor

1. Remove the Spring and two Screws A.
2. Dismount the Loading Motor.
3. Remove the Belt, a Screw B, two Screws C, a Guide and a Screw Unit.
4. Dismount the Carriage Motor.

Note : When assembling the Belt, use care so that it may not be contaminated by grease.

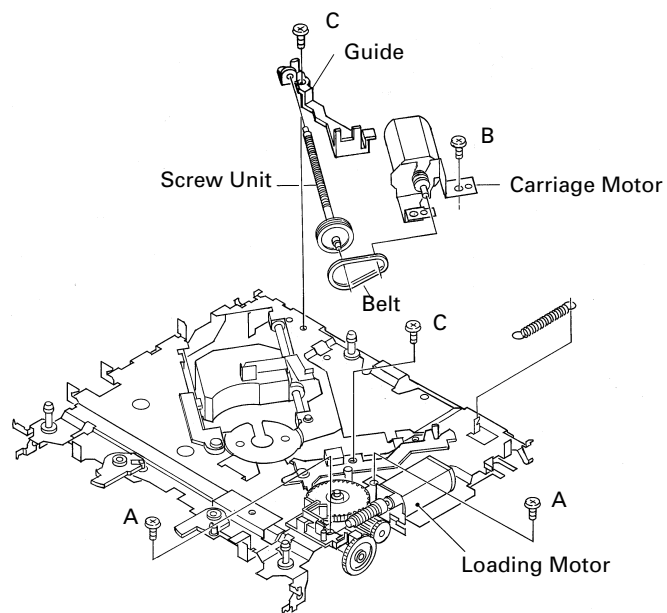

● Removing the Pickup Unit

1. Remove two Screws and a Shaft.
2. Dismount the Pickup Unit.

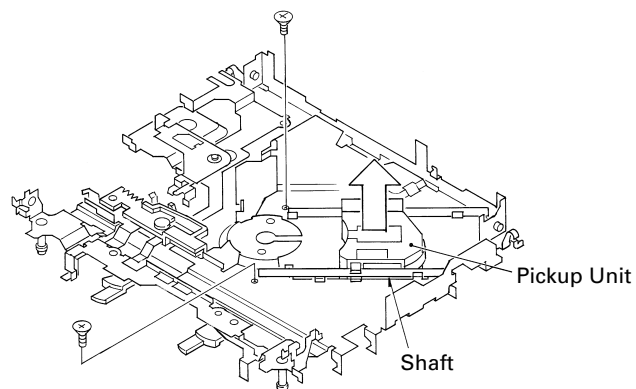

7.2 PARTS

7.2.1 IC

● Pin Functions(PE5091A)

Pin No.	Pin Name	I/O	Format	Function and Operation
1	MODEL1	I		Model select input
2	NL1	I		Noise level input
3	NL2DT	I		Noise level input 2
4	AVSS			A/D GND
5	ST	I		Stereo input
6	SD	I		SD signal input
7	AREF1			(D/A converter standard voltage)
8	KYDT	I		Key data input
9	DPDT	O	C	Key data output
10	SDBW	I		SDBW input
11	TUNPDI	I		PLL IC data input
12	TUNPDO	O	C	PLL IC data output
13	TUNPCK	O	C	PLL IC clock output
14	TUNPCE	O	C	PLL IC chip enable output
15	NC			Not used
16	XSI	I	C	LSI data input
17	XSO	O	C	LSI data output
18	XSCK	O	C	LSI clock output
19	DRST	O	C	RDS decoder reset output
20	ADPW	O	C	A/D converter power output
21	NC			Not used
22	VDCONT	O	C	VD power control output
23	CONT	O	C	Servo driver power control output
24	XAO	O	C	CD LSI data discernment control signal output
25	XRST	O	C	CD LSI reset output
26	XSTB	O	C	CD LSI strobe output
27	CLAMP	I		Disc clamp sense input
28	MIRR	I		Mirror detection input
29	FOK	I		Focus OK signal input
30	LOCK	I		Spindle lock detector input
31	CDLOAD	O	C	LOAD motor loading control output
32	TELIN	I		Cellular mute input
33	VSS			GND
34	CDEJECT	O		LOAD motor eject control output
35	CD5VON	O	C	CD +5V power supply control output
36-40	NC			Not used
41	SWVDD	O	C	Grille power supply control output
42	SYSPW	O	C	System power supply control output
43	NC			Not used
44	MUTE	O	C	Mute output
45	PEE	O	C	Beep tone output
46	LOCH	O	C	LOCH output
47	RDS57K	I		57kHzBP-OUT sense input
48	TUNPCE2	O	C	EEPROM chip enable output 2
49	NC			Not used
50	VCK	O	C	Clock output for electronic volume
51	VDT	O	C	Data output for electronic volume
52	ANTPW	O	C	Antenna power output
53	VST	O	C	Strobe pulse output for electronic volume
54-57	DEQ4-1	O	C	Direct EQ data output 4-1
58, 59	NC			Not used
60	RESET			Reset
61, 62	NC			Not used
63	ASENS	I		ACC power sense input

Pin No.	Pin Name	I/O	Format	Function and Operation
64	BSENS	I		Back up power sense input
65	DSENS	I		Grille detach sense input
66	TMUTE	O	C	Tuner mute output
67	LOCL	O	C	LOC L output
68	VDD			Power supply
69	X2			Crystal oscillator connection pin
70	X1			Crystal oscillator connection pin
71	IC			GND
72	NC			Not used
73	TESTIN	I		Test program mode input
74	AVDD			Positive power supply terminal for analog circuit
75	AVREF0			GND
76	SL	I		Signal level input
77	TEMP	I		Temperature detector input
78	VDSNS	I		Over voltage sense input
79	DSCSNS	I		Disc detect input
80	EJTSNS	I		Disc EJECT position detect input

Output Format	Meaning
C	C MOS output

IC's marked by* are MOS type.

Be careful in handling them because they are very liable to be damaged by electrostatic induction.

*PE5091A

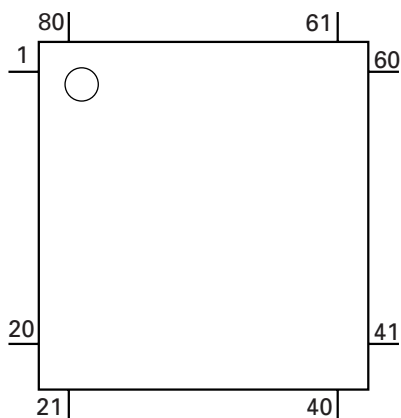

BR9010FV

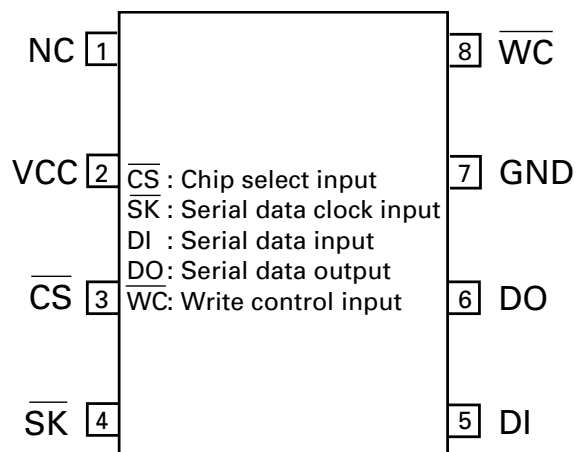

S-80834ANY

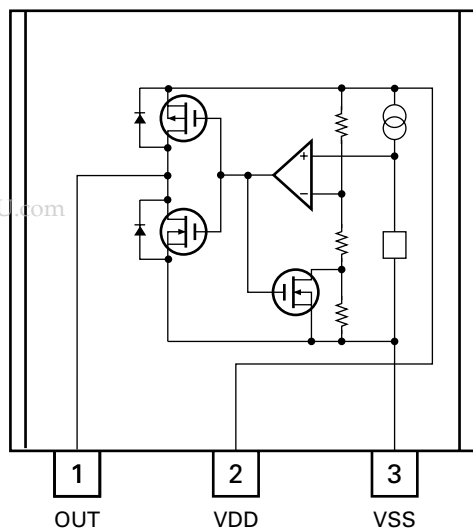

*PD6293A

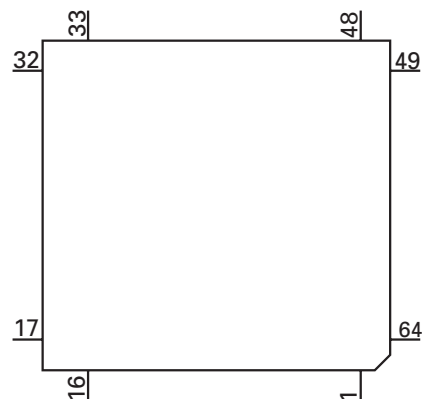

● Pin Functions (PD6293A)

Pin No.	Pin Name	I/O	Function and Operation
1-5	SEG4-0	O	LCD segment output
6-9	COM3-0	O	LCD common output
10	VLCD		LCD drive power supply
11-14	KST3-0	O	Key strobe output
15,16	KDT0,1	I	Key data input (analogue input)
17	REM	I	Remote control reception
18	DPDT	I	Display data input
19	NC		Not used
20	KYDT	O	Key data output
21	MODA		GND
22	X0		Crystal oscillator connection pin
23	X1		Crystal oscillator connection pin
24	VSS		GND
25,26	KDT2,3	I	Key data input
27	NC		Not used
28	KST4	O	Key strobe output
29-32	NC		Not used
33-55	SEG35-13	O	LCD segment output
56	VDD		Power supply
57-64	SEG12-5	O	LCD segment output

SN761029DL

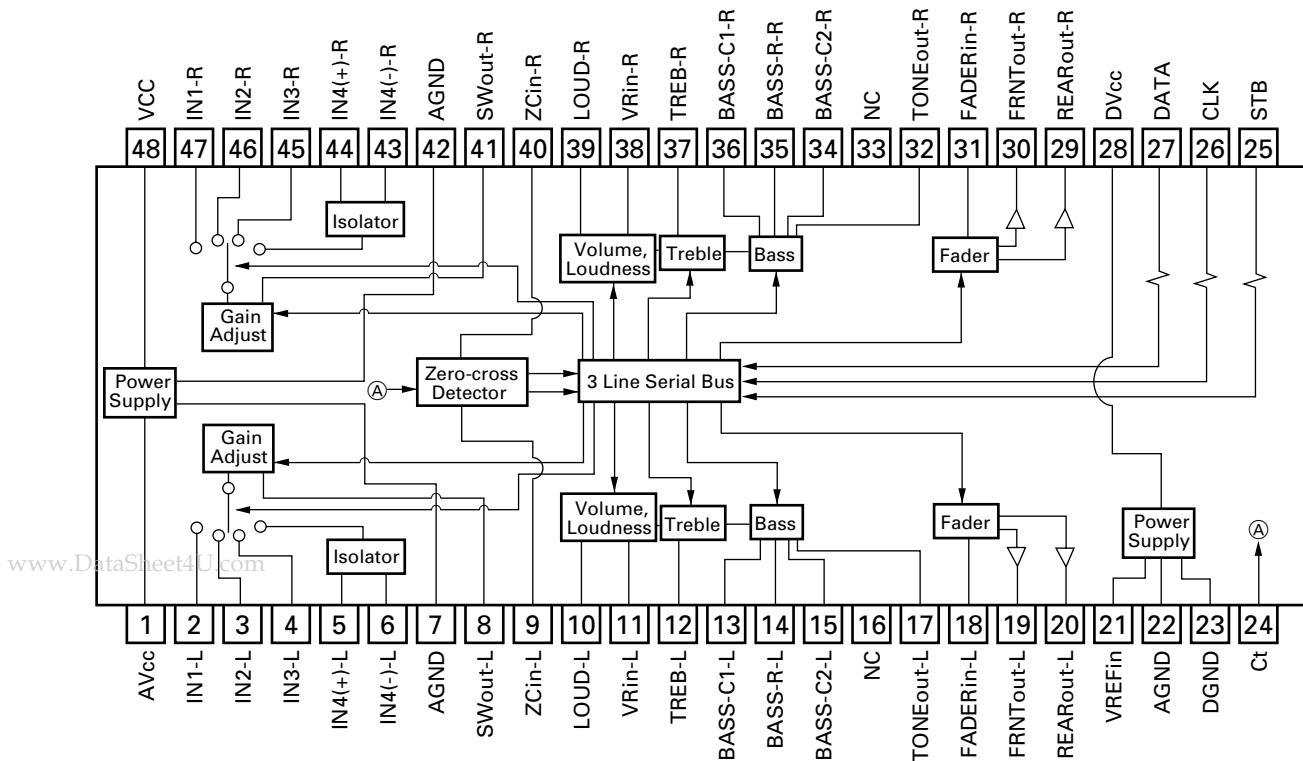

● Pin Functions (UPD63711GC)

Pin No.	Pin Name	I/O	Function and Operation
1	D.GND		Logic circuit GND
2	RFOK	O	RFOK signal output
3	RST	I	Reset signal input
4	A0	I	Command/parameter identification signal input
5	STB	I	Data strobe signal input
6	SCK	I	Clock signal input for serial data input/output
7	SO	O	Serial data and status signal output
8	SI	I	Serial data input
9	XTALEN	I	Crystal oscillation control pin
10	D.VDD		Positive power supply terminal to logic circuit
11	DA.VDD		Positive power supply terminal to D/A converter
12	R_OUT	O	Right channel audio output signal
13	DA.GND		D/A converter GND
14	REGC	I	The outside putting capacitor connection pin for SCF regulator
15	DA.GND		D/A converter GND
16	L_OUT	O	Left channel audio output signal
17	DA.VDD		Positive power supply terminal to D/A converter
18	R+	O	Right channel audio data output
19	R-	O	Right channel audio data output
20	L-	O	Left channel audio data output
21	L+	O	Left channel audio data output
22	X.VDD		Positive power supply terminal to crystal oscillation circuit
23	XTAL	I	Crystal oscillator connect pin
24	XTAL	O	Crystal oscillator connect pin
25	X.GND		Crystal oscillation circuit GND
26	D.VDD		Positive power supply terminal to logic circuit
27	EMPH	O	Output pin for the pre-emphasis data in the sub-Q code
28	FLAG	O	Flag output pin to indicate that audio data currently being output consists of noncorrectable data
29	DIN	I	Serial data input to internal DAC
30	DOUT	O	Serial audio data output
31	SCKIN	I	Serial clock input to internal DAC
32	SCKO	O	Audio data that is output from DOUT changes at rising edge of this clock
33	LRCKIN	I	LRCK signal input to internal DAC
34	LRCK	O	Signals to distinguish the right and left channels of the audio data output from DOUT
35	HOLD	O	Defect detection output
36	TX	O	Digital audio interface data output
37	D.GND		Logic circuit GND
38	C16M	O	Oscillator clock buffering output
39	LIMIT	I	Status of the pin is output at Bit 5 of the status output
40	D.VDD		Positive power supply terminal to logic circuit
41	LOCK	O	EFM synchronous detection signal
42	RFCK	O	Frame synchronous signal of XTAL-system
43	MIRR	O	MIRR output
44	PLCK	O	Monitor pin of bit clock
45	D.GND		Logic circuit GND
46	C1D1	O	Output pin for indicating the C1 error correction results
47	C1D2	O	Output pin for indicating the C1 error correction results
48	C2D1	O	Output pin for indicating the C2 error correction results
49	C2D2	O	Output pin for indicating the C2 error correction results
50	C2D3	O	Output pin for indicating the C2 error correction results
51	D.VDD		Positive power supply terminal to logic circuit
52	PACK	O	CD-TEXT PACK synchronous signal
53	TSO	O	CD-TEXT data serial output
54	TSI	I	CD-TEXT control parameter serial input
55	TSCK	I	CD-TEXT serial clock input
56	TSTB	I	CD-TEXT parameter strobe signal input
57	D.GND		Logic circuit GND

Pin No.	Pin Name	I/O	Function and Operation
58	TEST0	I	Test pin
59	TEST1	I	Test pin
60	ATEST	O	Test pin
61	A.GND		Analog circuit GND
62	FD	O	Focus drive output
63	TD	O	Tracking drive output
64	SD	O	Sled drive output
65	MD	O	Spindle drive output
66	DAC0	O	DAC output for adjustment
67	DAC1	O	DAC output for adjustment
68	DAC2	O	DAC output for adjustment
69	DAC3	O	DAC output for adjustment
70	A.VDD		Positive power supply terminal to analog circuit
71	EFM	O	EFM signal output
72	ASY	I	EFM comparator reference voltage input
73	C3T		3T detection capacitor additional pin
74	RFI	I	RF signal input for EFM data regulation
75	AGCO	O	RF signal output of after gain adjustment
76	AGCI	I	RF-AGC amplifier input
77	RFO	O	RF summing amplifier output
78	EQ2		RF amplifier equalizer parts additional pin
79	EQ1		RF amplifier equalizer parts additional pin
80	RF-	I	RF summing amplifier inverted input
81	A.GND		Analog circuit GND
82	A	I	Photo detector A input
83	C	I	Photo detector C input
84	B	I	Photo detector B input
85	D	I	Photo detector D input
86	F	I	Photo detector F input
87	E	I	Photo detector E input
88	A.VDD		Positive power supply terminal to analog circuit
89	REFOUT	O	Reference electric potential output
90	FE-	I	Focus error amplifier inverted input
91	FEO	O	Focus error amplifier output
92	TE-	I	Tracking error amplifier inverted input
93	TEO	O	Tracking error amplifier output
94	TE2	O	Tracking error output of after amplification
95	TEC	I	Tracking comparator input
96	A.GND		Analog circuit GND
97	PD	I	PD detection signal input for LD output monitor
98	LD	O	LD control current output
99	PN	I	APC circuit control polarity set pin
100	A.VDD		Positive power supply terminal to analog circuit

*UPD63711GC

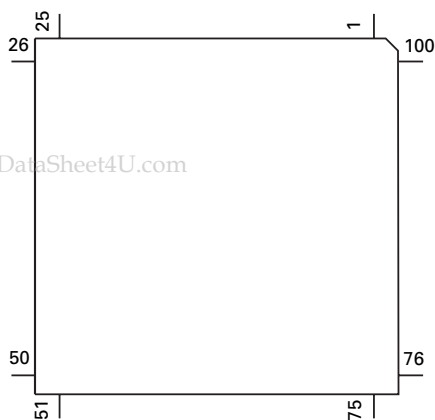

www.DataSheet4U.com

● Pin Functions (BA5985FM)

Pin No.	Pin Name	I/O	Function and Operation
1	FWD	I	Loading driver FWD input
2	OPIN1(+)	I	CH1 pre-amplifier input
3	OPIN1(-)	I	CH1 pre-amplifier inverted input
4	OPOUT1	O	CH1 pre-amplifier output
5	OPIN2(+)	I	CH2 pre-amplifier input
6	OPIN2(-)	I	CH2 pre-amplifier inverted input
7	OPOUT2	O	CH2 pre-amplifier output
8	VCC		Power supply
9	VOL(-)	O	Loading driver negative output
10	VOL(+)	O	Loading driver positive output
11	VO2(-)	O	Driver CH2 negative output
12	VO2(+)	O	Driver CH2 positive output
13	VO1(-)	O	Driver CH1 negative output
14	VO1(+)	O	Driver CH1 positive output
15	VO4(+)	O	Driver CH4 positive output
16	VO4(-)	O	Driver CH4 negative output
17	VO3(+)	O	Driver CH3 positive output
18	VO3(-)	O	Driver CH3 negative output
19	GND		GND
20	BIAS	I	Bias input
21	MUTE		Mute control
22	OPOUT3	O	CH3 pre-amplifier output
23	OPIN3(-)	I	CH3 pre-amplifier inverted input
24	OPIN3(+)	I	CH3 pre-amplifier input
25	OPOUT4	O	CH4 pre-amplifier output
26	OPIN4(-)	I	CH4 pre-amplifier inverted input
27	OPIN4(+)	I	CH4 pre-amplifier input
28	REV	I	Loading driver REV input

BA5985FM

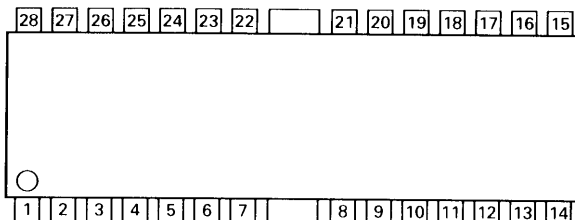

7.2.2 DISPLAY

● CAW1560

www.DataSheet4U.com

SEGMENT

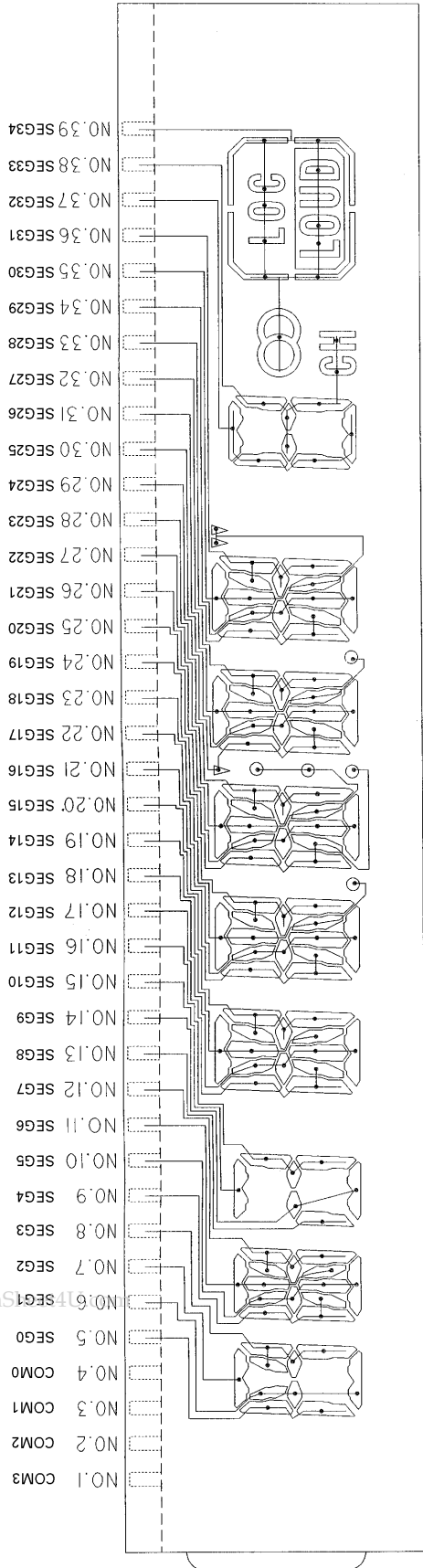

COMMON

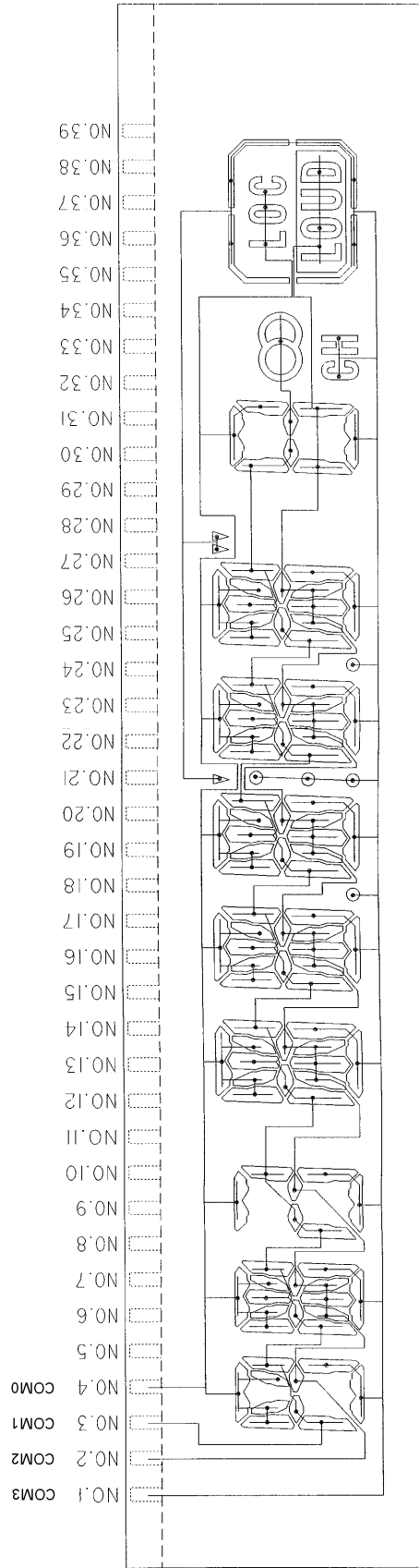

7.3 OPERATIONAL FLOW CHART

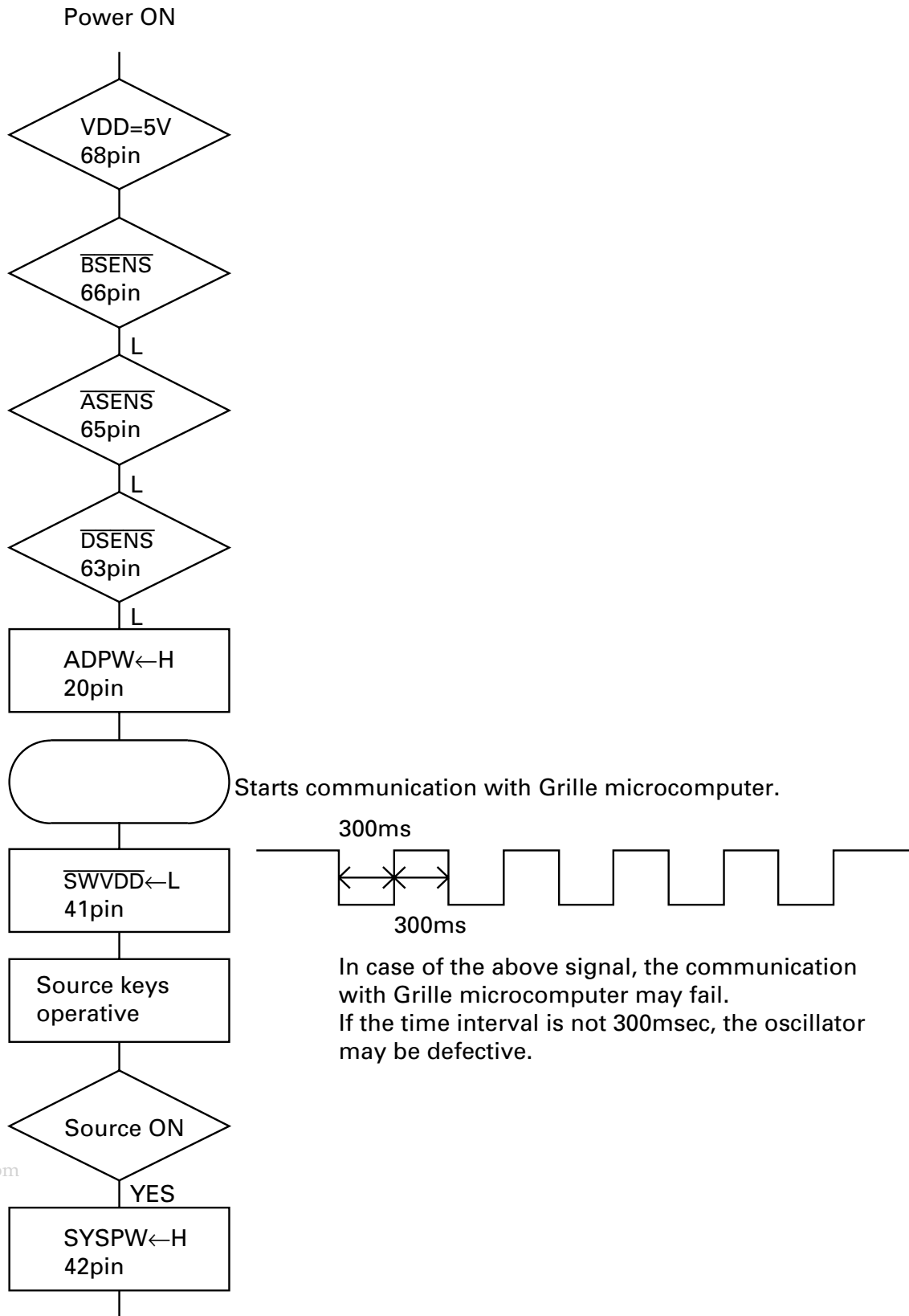

www.DataSheet4U.com

To each source's flow chart

8. OPERATIONS AND SPECIFICATIONS

8.1 OPERATIONS

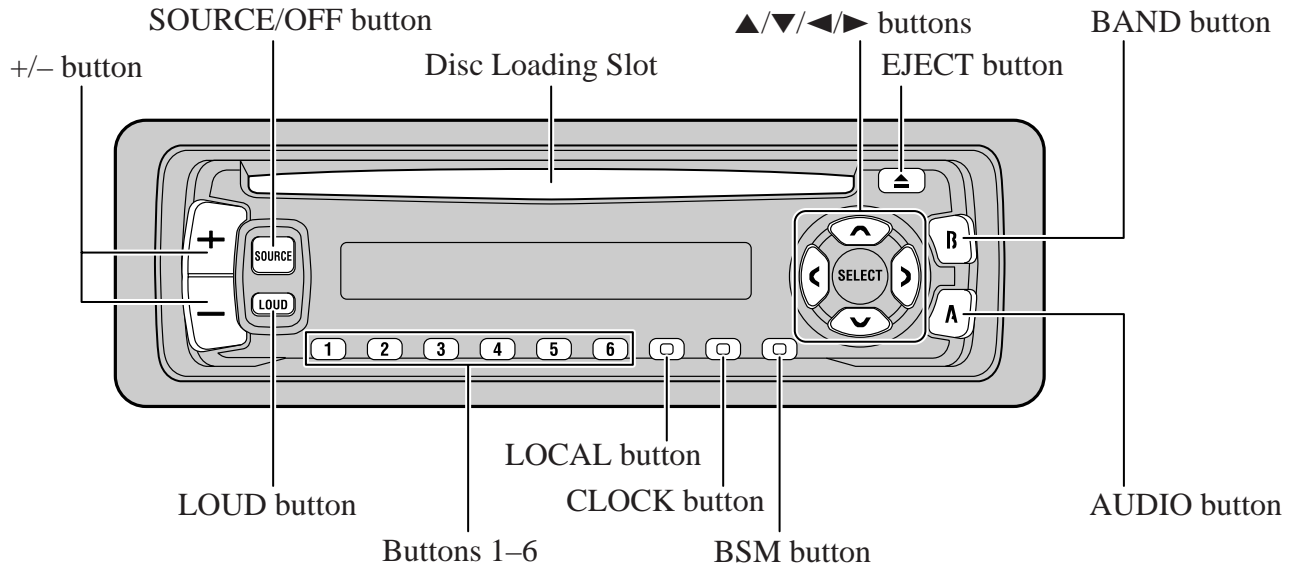

Basic Operation

To Listen to Music

The following explains the initial operations required before you can listen to music.

Note:

- Loading a disc in this product.

1. Select the desired source (e.g. Tuner).

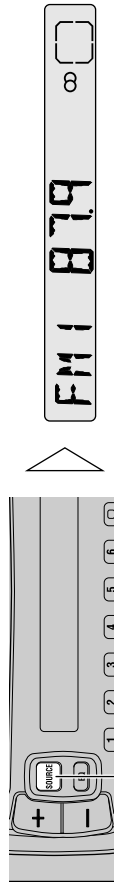

Each press changes the Source ...

Each press of the SOURCE/OFF button selects the desired source in the following order:
Built-in CD player → Tuner

Note:

- When no disc is set in this product, built-in CD player source will not change.
- When this product's blue/white lead is connected to the car's Auto-antenna relay control terminal, the car's Auto-antenna extends when this product's source is switched ON. To retract the antenna, switch the source OFF.

2. Raise or lower the volume.

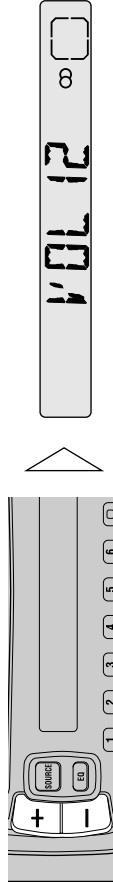

3. Turn the source OFF.

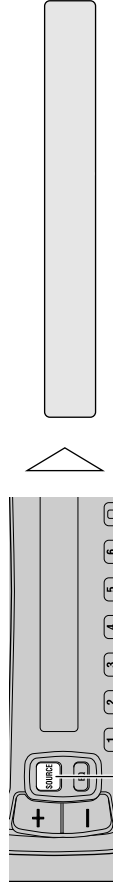

Hold for 1 second

Basic Operation of Tuner

Manual and Seek Tuning

- You can select the tuning method by changing the length of time you press the ◀/▶ button.

Manual Tuning (step by step)	0.5 seconds or less
Seek Tuning	0.5 seconds or more

Note:

- If you continue pressing the button for longer than 0.5 seconds, you can skip broadcast stations. Seek Tuning starts as soon as you release the button.
- Stereo indicator "◐◑" lights when a stereo station is selected.

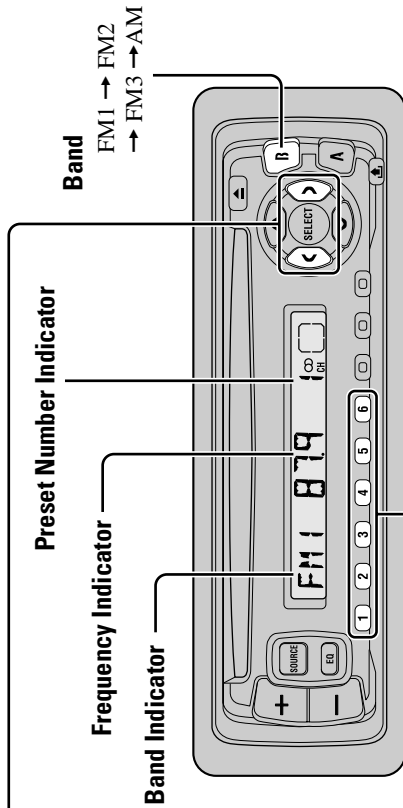

Preset Tuning

- You can memorize broadcast stations in buttons 1 through 6 for easy, one-touch station recall.

Preset station recall	2 seconds or less
Broadcast station preset memory	2 seconds or more

Note:

- Up to 18 FM stations (6 in FM1, FM2 and FM3) and 6 AM stations can be stored in memory.
- You can also use the ▲ or ▼ buttons to recall broadcast stations memorized in buttons 1 through 6.

Basic Operation of Built-in CD Player

Eject

Note:

- The CD function can be turned ON/OFF with the disc remaining in this product.
- A disc left partially inserted after ejection may incur damage or fall out.

Disc Loading Slot

Note:

- The built-in CD player plays one standard 12 cm or 8 cm (single) CD at a time. Do not use an adapter when playing 8 cm CD.

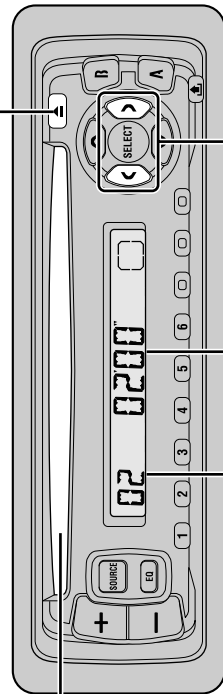

Track Number Indicator

Play Time Indicator

Track Search and Fast Forward/Reverse

- You can select between Track Search or Fast Forward/Reverse by pressing the ◀/▶ button for a different length of time.

Track Search	0.5 seconds or less
Fast Forward/Reverse	Continue pressing

Note:

- If a disc cannot be inserted fully or playback fails, make sure the recorded side is down. Push the EJECT button and check the disc for damage before reinserting it.
- If a disc is inserted with the recorded side up, it will be ejected automatically after a few moments.
- If the built-in CD player cannot operate properly, an error message (such as "ERROR-14") appears on the display.

Entering the Audio Menu

With this Menu, you can adjust the sound quality.

Note:

- After entering the Audio Menu, if you do not perform an operation within about 30 seconds, the Audio Menu is automatically canceled.

1. Select the desired mode in the Audio Menu.

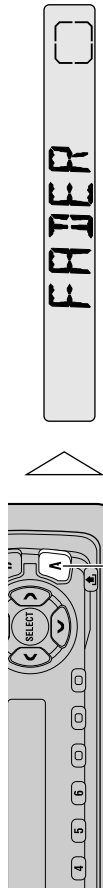

Each press changes the Mode ...

2. Operate a mode.

3. Cancel the Audio Menu.



Audio Adjustment

Audio Menu Functions

The Audio Menu features the following functions.

Balance Adjustment (FADER)

This function allows you to select a Fader/Balance setting that provides ideal listening conditions in all occupied seats.

1. Press the **AUDIO** button and select the **Fader/Balance mode (FADER)** in the **Audio Menu**.

2. Adjust front/rear speaker balance with the **▲▼** buttons.

“F15” – “R15” is displayed as it moves from front to rear.

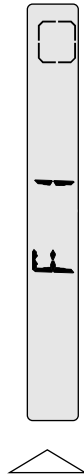

3. Adjust left/right speaker balance with the **◀▶** buttons.

“L9” – “R9” is displayed as it moves from left to right.

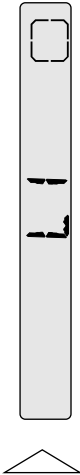

Note:

- FADER “0” is the proper setting when 2 speakers are in use.

Bass Adjustment (BAS)

You can adjust a Bass level as desired.

1. Press the **AUDIO** button and select the **Bass mode (BAS)** in the **Audio Menu**.

2. Boost or attenuate the bass level with the **▲▼** buttons.

The display shows “+6” – “-6”.



Treble Adjustment (TRE)

You can adjust a Treble level as desired.

1. Press the **AUDIO** button and select the **Treble mode (TRE)** in the **Audio Menu**.

2. Boost or attenuate the treble level with the **▲▼** buttons.

The display shows “+6” – “-6”.

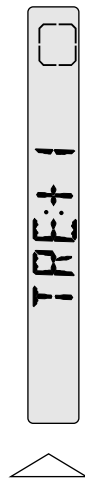

Loudness Adjustment (LOUD)

The Loudness function compensates for deficiencies in the low and high sound ranges at low volume.

- Switch the Loudness function **ON/OFF** with the **LOUD** button.

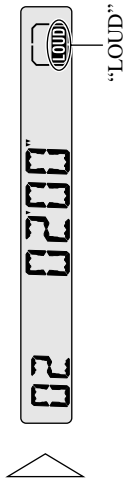

Connection Diagram

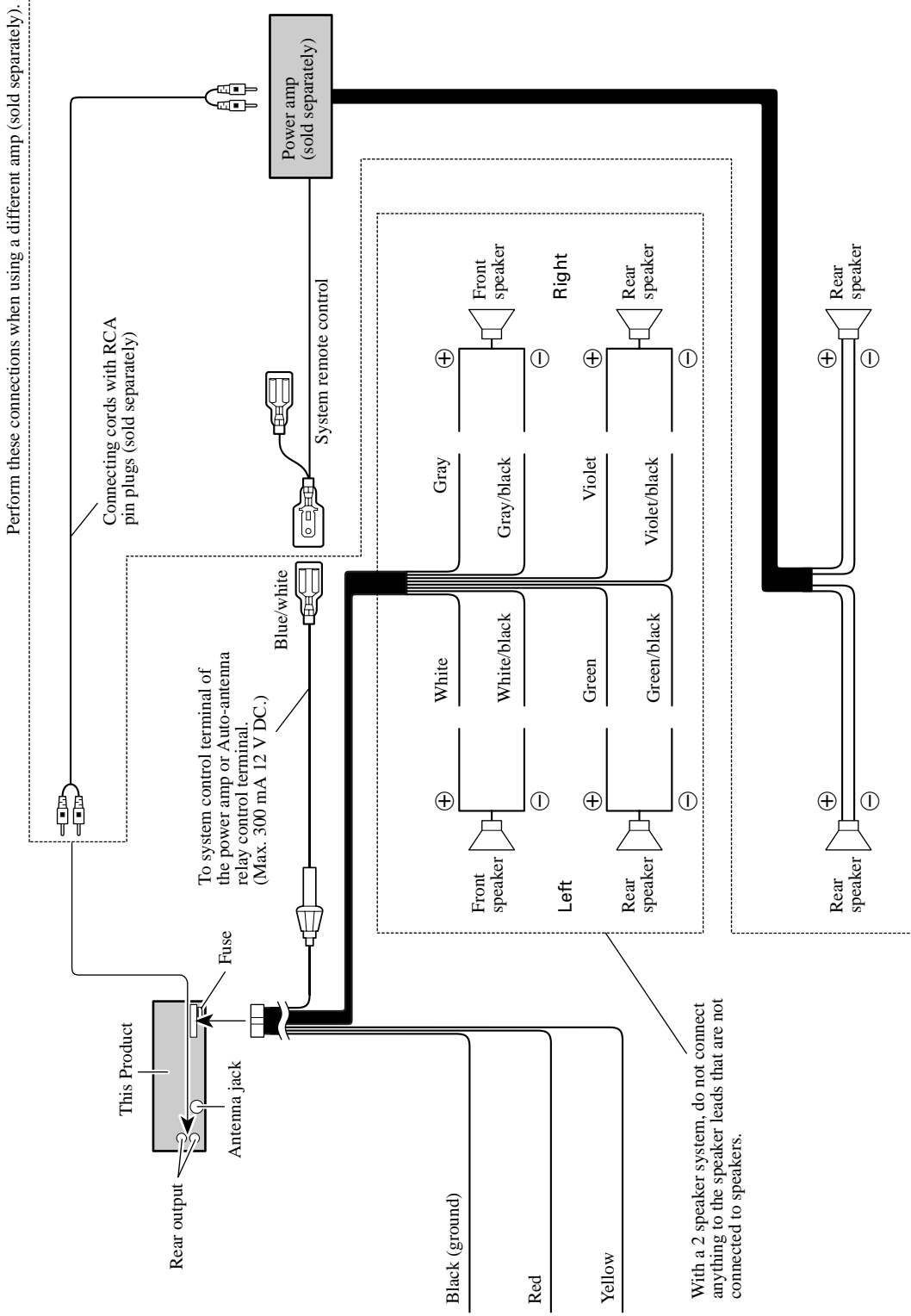

To vehicle (metal) body.

To electric terminal controlled by ignition switch (12 V DC) ON/OFF.

To terminal always supplied with power regardless of ignition switch position.

8.2 SPECIFICATIONS

General

Power source	14.4 V DC (10.8 – 15.1 V allowable)
Grounding system	Negative type
Max. current consumption	10.0 A
Dimensions	
(DIN) (chassis)	178 (W) × 50 (H) × 159 (D) mm [7 (W) × 2 (H) × 6-1/4 (D) in]
(nose)	188 (W) × 58 (H) × 19 (D) mm [7-3/8 (W) × 2-1/4 (H) × 3/4 (D) in]
(D) (chassis)	178 (W) × 50 (H) × 164 (D) mm [7 (W) × 2 (H) × 6-1/2 (D) in]
(nose)	170 (W) × 48 (H) × 14 (D) mm [6-3/4 (W) × 1-7/8 (H) × 1/2 (D) in]
Weight	1.4 kg (3.1 lbs)

Amplifier

Continuous power output	is 17 W per channel min. into 4 ohms, both channels driven 50 to 15,000 Hz with no more than 5% THD.
Maximum power output	40 W × 4
Load impedance	4 Ω (4 – 8 Ω allowable)
Preout maximum output level/ output impedance	2.2 V/1 kΩ
Tone controls	
(Bass)	±12 dB (100 Hz)
(Treble)	±12 dB (10 kHz)
Loudness contour	+10 dB (100 Hz), +7 dB (10 kHz) (volume: –30 dB)

CD player

System	Compact disc audio system
Usable discs	Compact disc
Signal format	Sampling frequency: 44.1 kHz Number of quantization bits: 16; linear
Frequency characteristics	5 – 20,000 Hz (±1 dB)
Signal-to-noise ratio	94 dB (1 kHz) (IHF-A network)
Dynamic range	92 dB (1 kHz)
Number of channels	2 (stereo)

FM tuner

Frequency range	87.9 – 107.9 MHz
Usable sensitivity	10 dBf (0.9 μV/75 Ω, mono, S/N: 30 dB)
50 dB quieting sensitivity	15 dBf (1.5 μV/75 Ω, mono)
Signal-to-noise ratio	70 dB (IHF-A network)
Distortion	0.3% (at 65 dBf, 1 kHz, stereo)
Frequency response	30 – 15,000 Hz (±3 dB)
Stereo separation	40 dB (at 65 dBf, 1 kHz)
Selectivity	70 dB (2ACA)
Three-signal intermodulation (desired signal level)	30 dBf (two undesired signal level: 100 dBf)

AM tuner

Frequency range	530 – 1,710 kHz (10 kHz)
Usable sensitivity	18 μV (S/N: 20 dB)
Selectivity	50 dB (±10 kHz)

Note:

- Specifications and the design are subject to possible modification without notice due to improvements.