

SUPER FLUX LED – P4 (piranha type), Wide Angle

DATA SHEET 3561 REV.

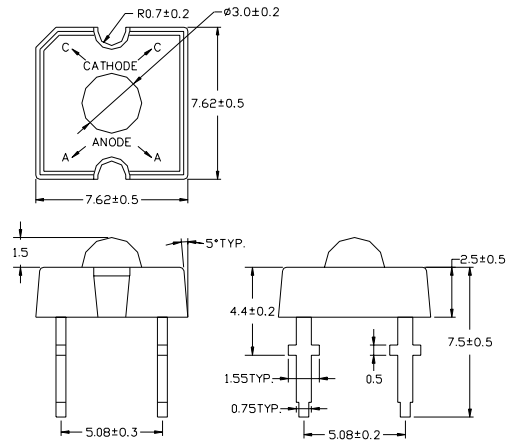
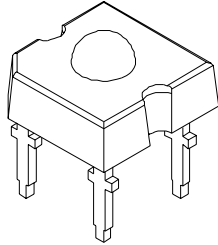

Absolute Maximum Rating: ($T_a = 25^\circ\text{C}$)

Symbol	Description	Max	Unit
P_D	Power dissipation	140	mW
V_R	Reverse voltage	5	V
I_F	Forward current	70	mA
T_{opr}	Operating temperature range	-30°C to 100°C	
T_{stg}	Storage temperature range	-35°C to 100°C	
Lead soldering temperature $\leq 260^\circ\text{C}$ for 3 seconds			

Electro-optical Characteristic: ($T_a = 25^\circ\text{C}$)

Part No.	Chip		Wave-length nm	IF (Forward Current) mA	Vf (volt) @ 20mA Typ.	Iv (mcd) @ 20mA Typ.	Φ_v (mim) at IF Typ.	Viewing Angle $2\theta_{1/2}$ Degree
	Material	Color						
LTP400-BHC-1	GaN	Green	470	30	3.3	900	1200	40
LTP400-GHC-2	GaN	Green	525	30	3.7	3200	1500	40
LTP400-WHC-1	GaN	White	--	30	3.3	1600	1200	70
LTP400-YTC-1	GaAlInP	Yellow	592	70	2.0	1000	2400	70
LTP400-YTC-2	TS GaAlInP	Yellow	592	70	2.0	1600	2800	70
LTP400-RTC-1	GaAlInP	Red	626	50	2.0	700	2500	70
LTP400-RTC-2	TS GaAlInP	Red	626	70	2.4	1500	5000	70

Features

- High current operation and high flux output
- Low thermal resistance and low profile
- Wide viewing angle

Description

The P4 (piranha type) is a clear lensed 7.6mm x 7.6mm square four-leaded package. This low profile design improves power dissipation and allows higher operating currents. Ideal applications for this product include emergency lighting, channel letters, interior/exterior automotive and truck lighting, strip lighting, outdoor signage and general illumination.

SENSITRON

SEMICONDUCTOR

DISCLAIMER:

- 1- The information given herein, including the specifications and dimensions, is subject to change without prior notice to improve product characteristics. Before ordering, purchasers are advised to contact the Sensitron Semiconductor sales department for the latest version of the datasheet(s).
- 2- In cases where extremely high reliability is required (such as use in nuclear power control, aerospace and aviation, traffic equipment, medical equipment, and safety equipment), safety should be ensured by using semiconductor devices that feature assured safety or by means of users' fail-safe precautions or other arrangement.
- 3- In no event shall Sensitron Semiconductor be liable for any damages that may result from an accident or any other cause during operation of the user's units according to the datasheet(s). Sensitron Semiconductor assumes no responsibility for any intellectual property claims or any other problems that may result from applications of information, products or circuits described in the datasheets.
- 4- In no event shall Sensitron Semiconductor be liable for any failure in a semiconductor device or any secondary damage resulting from use at a value exceeding the absolute maximum rating.
- 5- No license is granted by the datasheet(s) under any patents or other rights of any third party or Sensitron Semiconductor.
- 6- The datasheet(s) may not be reproduced or duplicated, in any form, in whole or part, without the expressed written permission of Sensitron Semiconductor.
- 7- The products (technologies) described in the datasheet(s) are not to be provided to any party whose purpose in their application will hinder maintenance of international peace and safety nor are they to be applied to that purpose by their direct purchasers or any third party. When exporting these products (technologies), the necessary procedures are to be taken in accordance with related laws and regulations.