

MITSUBISHI ELECTRIC CORPORATION

SPEC. NAME SPECIFICATION	DATE	* Oct., 3, '00		
	PREPARED BY.	M. Tokimoto, S. Honda		
	CHECKED BY.	T. Sakai, S. Kiyama		
	APPROVED BY.	K. Koyama		

ITEM **INTEGRATED CIRCUIT**

1. TYPE NO. M63100BFP
2. FUNCTION Spindle + Loading motor driver +CTL interface
3. APPLICATION VTR
4. PACKAGE 42 Pin Power SSOP
5. CIRCUIT DRAWING NO. —
6. PIN CONFIGURATION

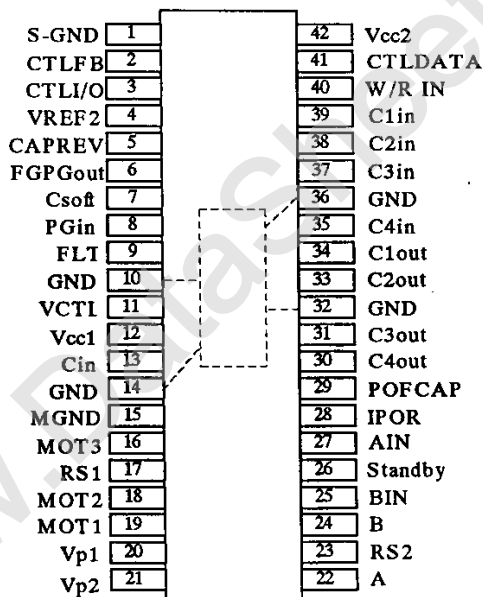

42 pin Power SSOP (42P9R)

Remark: GND pin(10pin,14pin,32pin,36pin) are connected to the bottom plate.

TITLE SPECIFICATION	SPEC. NO. GNOK - M63100BFP - 30	REV. *	PAGE 1/24
------------------------	------------------------------------	-----------	--------------

7. BLOCK DIAGRAM

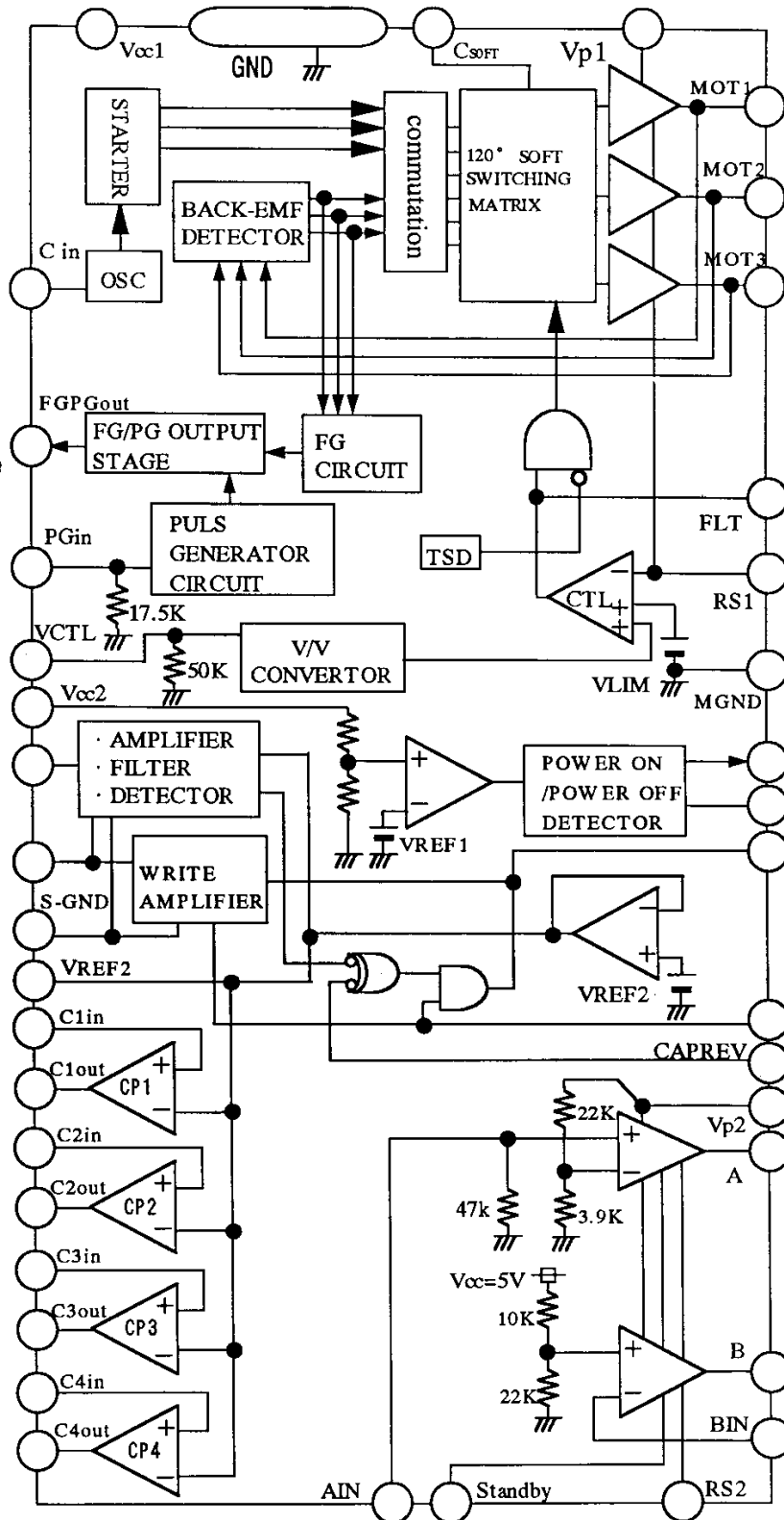

TITLE	SPEC. NO.	REV.	PAGE
SPECIFICATION	GNOK - M63100BFP - 30	*	2/24

8.PIN FUNCTION

TERMINAL	SYMBOL	TERMINAL FUNCTION	TERMINAL	SYMBOL	TERMINAL FUNCTION
1	S-GND	GND for interface function	22	A	Loading motor phase A output
2	CTL FB	Control head feedback	23	RS2	Loading motor current output
3	CTL I/O	Control head input/output	24	B	Loading motor phase B output
4	VREF2	Reference voltage 2	25	BIN	Power amp. B inverting input
5	CAPREV	Capstan reverse input	26	Standby	Standby signal input
6	FGPGout	FG and PG output	27	AIN	Phase A input
7	Csoft	Capacitor for soft switching	28	IPOR	Power On Reset fail output
8	PGin	PG Sensor input	29	POFCAP	Capacitor for IPOR timing set
9	FLT	Current feedback amp. output	30	C4out	Comparator C4 output
10	GND	GND	31	C3out	Comparator C3 output
11	VCTL	Drum motor speed control	32	GND	GND
12	Vcc1	5.0V Power supply	33	C2out	Comparator C2 output
13	Cin	OSC Capacitor input	34	C1out	Comparator C1 output
14	GND	GND	35	C4in	Comparator C4 input
15	MGND	GND terminal of current limit VL	36	GND	GND
16	MOT3	Drum motor phase W output	37	C3in	Comparator C3 input
17	RS1	Drum motor GND	38	C2in	Comparator C2 input
18	MOT2	Drum motor phase V output	39	C1in	Comparator C1 input
19	MOT1	Drum motor phase U output	40	W/R IN	Write/Read input
20	Vp1	To Drum motor power supply	41	CTL DAT	Control head data output
21	Vp2	To Loading motor power supply	42	Vcc2	5.0V Power supply for interface function

9.ABSOLUTE MAXIMUM RATING (Ta=25°C)

SYMBOL	PARAMETER	CONDITIONS	RATING	UNITS
Drum motor driver				
Vcc1/Vcc2	5V supply voltage		6.5	V
Vp	Motor supply voltage		16.5	V
Io	Output current		1.0	A
Bi-DIRECTIONAL MOTOR				
Vp	Supply voltage		16.5	V
Io	Output current		1.0	A
Pt	Power dissipation	Free Air	1.5	W
Kθ	Thermal derating	Free Air	83	°C/W
Tj	Junction temperature		150	°C
Topr	Operating temperature		-10~70	°C
Tstg	Storage temperature		-40~150	°C

10.RECOMMENDED OPERATING CONDITIONS

SYMBOL	PARAMETER	LIMITS			UNITS
		MINIMUM	TYPICAL	MAXIMUM	
Drum motor driver					
Vcc1/Vcc2	5V Power supply	4.5	5.0	5.5	V
Vp	Motor Power supply	11.5	12.0	15.1	V
Io	Maximum output drive current	—	—	1.0	A
Bi-DIRECTIONAL MOTOR					
Vp	Motor Power supply	11.5	12.0	15.1	V
Io	Maximum output drive current	—	—	0.8	A

11.THERMAL REDATING

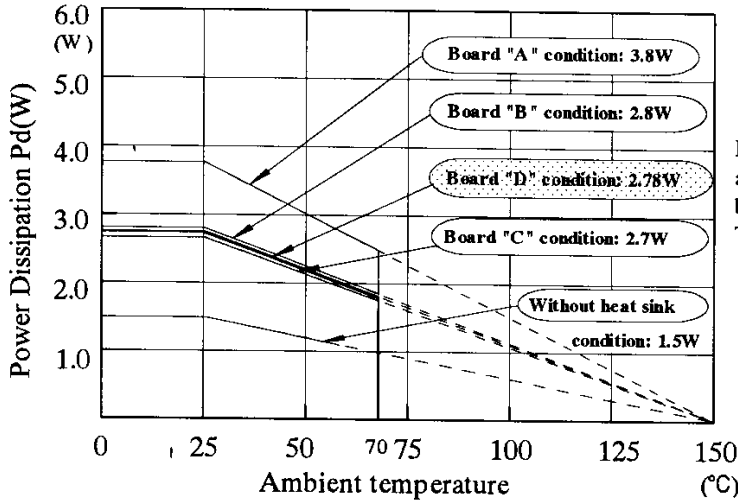

Power-SSOP
[bottom view]

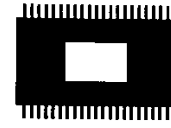

It is possible that this power SSOP can get a great power dissipation without a heat sink by the metal design of a board.
This power SSOP can get 2.78W under board "D"

*BoardA~BoardC

- Board material: Grass epoxy (FR-4)
- Board size S=70 x 70 mm
- Board thickness t=1.6mm
- Metal Material: Copper thickness: t=18μm

Metal 1 (Face)

Metal 2 (Back)

Board A (2 metal)

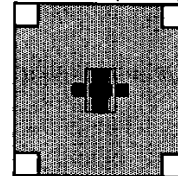
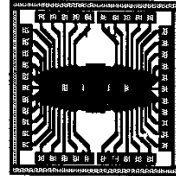

Board B (2 metal)

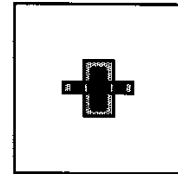
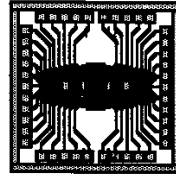

Board C (1 metal)

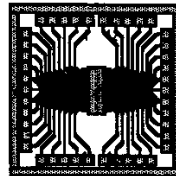

*BoardD

- Board material: (FR-2) (1 metal)
- Board size S=380 x 250 mm
- Board thickness t=1.65mm

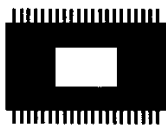

Power-SSOP
[bottom view]

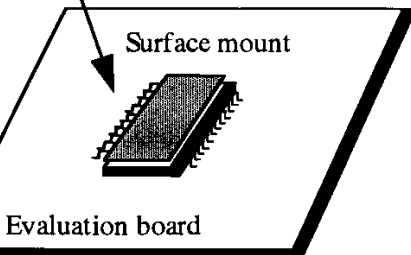

<Power dissipation simulation with Board D>

Characteristics conditions: Vp1=Vp2=15.1V, Vcc1=Vcc2=5.5V, Drum motor=1500rpm

(1)Power dissipation for Drum motor(worst case) $P_{Drum}=(15.1V-V_{motor})\cdot 0.08A$
 $=7.6V\cdot 0.08A=0.608W$

(2)Power dissipation for Loading motor(worst case) $P_{Loading}=(15.1V-V_{motor})\cdot 0.1A$
 $=6.1V\cdot 0.1A=0.61W$

(3)Power dissipation for Vcc1+Vcc2(worst case) $P_{Others}=5.5V\cdot 0.0405A+5.5\cdot 0.02A$
 $=0.223W+0.11W=0.333W$

Total: $P_{Drum}+P_{Loading}+P_{Others}=0.608W+0.61W+0.333W=1.551W$

$1.551W\cdot 45^{\circ}C/W=69.8^{\circ}C \implies 60^{\circ}C(\text{ambient temperature})+69.8^{\circ}C=129.8^{\circ}C$

Worst junction temperature is 129.8°C
(Conditions: ambient temperature 60°C)

12. ELECTRICAL CHARACTERISTICS

(Drum motor driver)

(Vcc1/Vcc2=5V, Vp=12V, Ta=25°C unless otherwise noted)

No.	SYMBOL	PARAMETERS	CONDITIONS	LIMITS			UNITS	
				MIN.	TYP.	MAX.		
General-1<Activ mode> ----- conditions: Vctl<0.7V, Standby=0V, C1in=C2in=C3in=C4in=5V								
1	Icc-H	5V Supply current-1	Icc1+Icc2 AIN=5V<H> -----> A= "H" BIN=0V<L> -----> B="H"	—	27	40.5	mA	
2-1	Ip-H1	12V Supply current-1	Ip1+Ip2 AIN=5V<H> -----> A= "H" BIN=0V<L> -----> B="H"	—	8.2	12.3	mA	
2-2	Ip-H2	12V Supply current-2	Ip1+Ip2 AIN=0V<L> -----> A="L" BIN=5V<H> -----> B="L"	—	43.2	64.8	mA	
General-2<Standby mode> ----- conditions: Vctl<0.7V, Standby=5V, C1in=C2in=C3in=C4in=5V								
3	Icc-L'	5V Supply current-2	Supply current from Vcc1+ Vcc2	—	27	40.5	mA	
4	Ip-L	12V Supply current-2	Supply current from Vp1+Vp2	—	4.6	6.9	mA	
Drum motor driver								
5	VsatD	Saturation voltage	at load current 500mA	Top side	—	1.0	1.35	V
				Bottom side	—	0.3	0.5	V
6	fCLK	Clock frequency	Internal clock frequency Cin(13pin)-GND Capacitor=150pF NOTICE(3) Cin(13pin)-Vcc Resistor=200Kohm	47.0	48.5	50.0	kHz	
7	Vctl	Control voltage input range	Usefull range approximately 0.7V~4.0V at Vcc1=5.0V condition.	0	—	Vcc1	V	
8	Vos	Vctl terminal offset voltage	Vctl terminal dead zone	0.58	0.64	0.70	V	
9	Gio	Control gain	Rs=0.47Ω Control voltage= 1V - 3V	0.236	0.258	0.279	A/V	
10	ILIM	Current limit	Rs=0.47Ω	0.60	0.85	1.0	A	
11	VEMF	B-EMF Comparator detect level	B-EMF voltage sensing level for commutation NOTICE(5)	12	—	80	mVp-0	
12	Time erro	B-EMF circuits time error	TECHNICAL MANUAL-6.	-1.40	—	+1.40	uS	
PG Circuit								
13	VPgin	Input voltage range	PGin terminal input voltage range	-0.3	—	Vcc1	V	
14	RinPG	Input resistor		12	17.5	23	kΩ	
15	Vcsw	Input comparator threshold level		63	73	83	mVp-GND	
FG/PG output								
16	VOL	Output voltage LOW	Load current Io=2mA	—	—	1.0	V	
17	RFG/PG	internal resistor		8K	10K	12K	Ω	
18	tTHL	Transition time	High to Low at CL=50pF	—	0.1	0.5	μS	
19	RF/C	Ratio of FG(negative) and B-EMF(zero cross)	NOTICE(6)	—	1:2	—	—	

(Vcc1/Vcc2=5V, Vp=12V, Ta=25°C unless otherwise noted)

No.	SYMBOL	PARAMETERS	CONDITIONS	LIMITS			UNITS
				MIN.	TYP.	MAX.	
20	δ	Duty factor	FG duty factor	45	50	55	%
21	tPL	Puls width LOW		5	10	15	μ S
Cin pin							
22	Vcin	Input voltage range		-0.3	—	Vcc1	V
23	Iin-H	Input impedance-H	Input voltage = 5V	0.4	1.0	1.6	mA
	Iin-L	Input impedance-L	Input voltage = 0V	-2.0	—	—	μ A
24	Vth1	Comparator threshold voltage 1		2.0	2.5	3.0	V
25	Vth2	Comparator threshold voltage 2		0.4	0.7	1.0	V

NOTICE

(1) With regard to start up timing, it depend on a servo circuit.
See the technical manual.—page(19/23)

(2) Drum motor drive control signal diagram

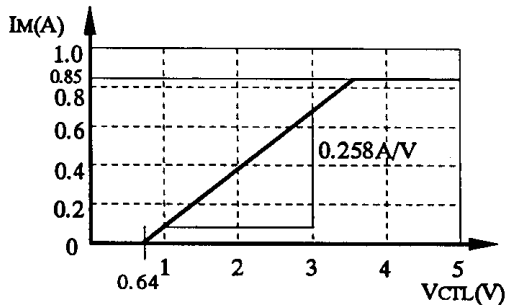

(4) Saturation Characteristic
<Drum motor driver part>

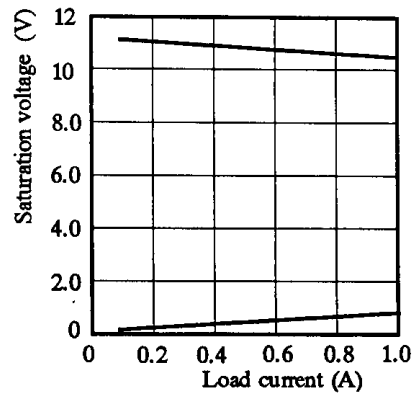

(3) Internal clock(fCLK)

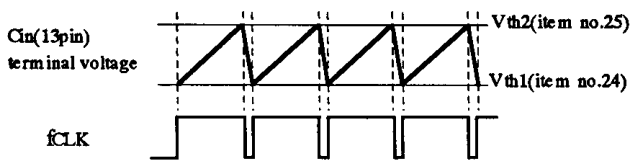

Remark <Item No.6; fCLK>

Conditions; Vcc1, Vcc2=4.5V~5.5V, Tj=0~100°C
Cin(13pin)-GND Capacitor=150pF
Cin(13pin)-Vcc Resistor=200Kohm

CONFIRMED PARAMENTERS AT ES EVALUATION

No.	SYMBOL	PARAMETERS	CONDITIONS	LIMIT			UNITS
				MIN.	TYP.	MAX.	
6	fCLK	Clock frequency	Above conditions	46.0	48.5	51.0	KHz

As the ES evaluation result, the temperature and Vcc variation is +2%(max.).
Therefore, the specification of item no.6 (fCLK) is as page (5/23) in Vcc=5V, Ta=25°C

(5) B-EMF Comparator detection level
(minimum level)

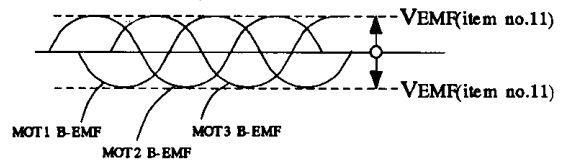

(6) Ratio of FG(negative) and B-EMF(zero cross)

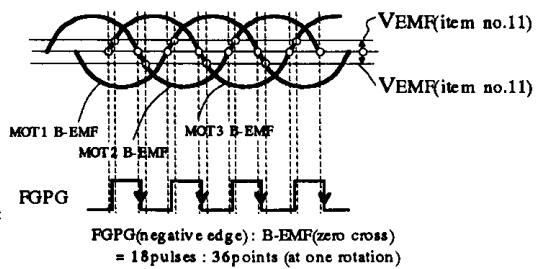

(Loading motor driver)

(Vcc1/Vcc2=5V, Vp=12V, Ta=25°C unless otherwise noted)

No.	SYMBOL	PARAMETERS	CONDITIONS	LIMITS			UNITS	
				MIN.	TYP.	MAX.		
Standby pin								
26	IILSTE	Input current low	Vstd=0V	-10	-1	—	μA	
27	IIHSTE	Input current high	Vstd=5V	—	250	420	μA	
28	VIL	Input voltage low	Loading motor on	0	—	1.5	V	
29	VIH	Input voltage high	Standby mode	3.5	—	Vcc1	V	
30	Vth	Threshold voltage		—	2.5	—	V	
Loading motor driver								
31	VsatL	Saturation voltage	at load current 300mA	Top side	—	1.0	1.45	V
				Bottom side	—	0.2	0.35	V
32	IBL(BIN)	Input bias current	BIN=0V	-1.0	—	—	μA	
33	R(AIN)	Input resistanse		33K	47K	61K	Ω	
34	Ath	A amp. threshold voltage		1.4	1.81	2.2	V	
35	Bth	B amp. threshold voltage		3.1	3.44	3.7	V	
36	SR	Slew rate		0.2	1.0	—	V/μS	

Saturation Characteristic<Loading motor driver part>

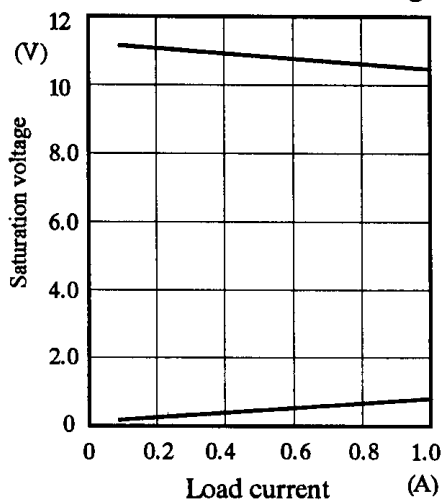

(Interface Function)

(Vcc1/Vcc2=5V, Vp=12V, Ta=25°C unless otherwise noted)

No.	SYMBOL	PARAMETERS	CONDITIONS	LIMITS			UNITS
				MIN.	TYP.	MAX.	
Vcc2 Supply pin							
40	Icc2A	5V Supply current 2-A	Supply current from Vcc2 at read mode <small>between CTLIO and Vrd2 resistor=650ohm CAPREV=5V,WRIn=0V,other pins=>open</small>	—	6	9	mA
41	Icc2B	5V Supply current 2-B	Supply current from Vcc2 at write mode <small>between CTLIO and Vrd2 resistor=650ohm CAPREV=5V,WRIn=0V,CTLDATA=0V,other pins=>open</small>	—	10	15	mA
CTL I/O characteristic at read mode (W/R IN < 0.5V) condition							
42	VinCTL1	Input voltage range (peak to peak)	f=500Hz	0.35	—	—	mV
43	VinCTL2		f=30kHz; non-linear operation	—	—	200	mV
44	BFLT	Bandwidth low-pass filter		2.8	3.5	4.2	kHz
45	IinCTL	CTL I/O Terminal input current	at read mode condition. CTLI/O=2.5V	—	0.1	0.3	μA
46	Gain	Gain at read mode	CTLFB resistor = 0Ω	44.5	49.5	54.5	dB
CTL I/O characteristic at write mode (W/R IN > 3.5V) condition							
47	Vout1	CTL I/O Terminal Low output voltage	CTL DATA=High and load current 3mA.	—	—	0.4	V
48	Vout2	CTL I/O Terminal High output voltage	CTL DATA=Low and load current 3mA.	4.6	—	—	V
W/R IN pin							
49	VinW/R1	Input voltage range	Read mode	0.0	—	0.5	V
50	VinW/R2		Write mode; analog	1.6	—	3.3	V
51	IinW/R1	Input current	Read mode	-1.5	-0.5	—	μA
52	IinW/R2		Write mode	—	0.2	0.5	μA
VREF2 pin							
53	VREF2out	Output voltage	Io=±4mA	2.4	2.5	2.6	V
54	I _{tot}	Output current	including write current	-4	—	4	mA
55	Ro	Output resistance		—	2	3	Ω
CAPREV pin							
56	VIHCR	Input high voltage		2.0	—	Vcc2	V
57	VILCR	Input low voltage		0.0	—	0.8	V
58	IIHCR	Input current low	V _{CAPREV} =5.0V	—	—	10	μA
59	IILCR	Input current high	V _{CAPREV} =0V	-10	—	—	μA

(Interface Function)

(Vcc1/Vcc2=5V, Vco=12V, Ta=25°C unless otherwise noted)

No.	SYMBOL	PARAMETERS	CONDITIONS	LIMITS			UNITS
				MIN.	TYP.	MAX.	
CTL DATA pin characteristic at write mode condition							
60	VIHCD	Input high voltage		2.2	—	Vcc2	V
61	VILCD	Input low voltage		0.0	—	1.2	V
62	IIHCD	Input current high	VCTLDATA=5.0V	—	—	10	μA
63	IILCD	Input current low	VCTLDATA=0V	-630	—	—	μA
CTL DATA pin characteristic at read mode condition.							
64	VOLCD	Output voltage low	Load current IOL=2mA	—	—	1.0	V
65	RCD	internal resistor		8K	10K	12K	Ω
POR function : IPOR out and POFCAP pins							
66	VOPO	Operating voltage range	at decreasing Vcc2	3.5	—	5.5	V
67	VOLOP	Output voltage low	Load current 0.5mA condition	—	—	1.0	V
68	VOHOP	Output voltage high	Load current -0.5mA condition	Vcc-1.2	—	—	V
69	td	Delay time	CPOFCAP=68nF	32	50	65	mS
70	VTL1	Threshold level		4.52	—	4.78	V
71	VTLhys1	Hysteresis		16	35	50	mV

Write current characteristic

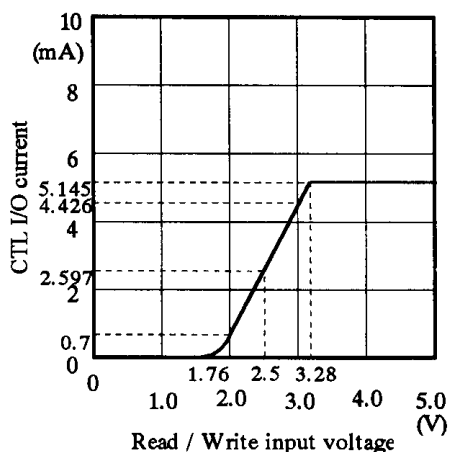

(Interface Function, Thermal protection)

 ($V_{cc1}/V_{cc2}=5V, V_p=12V, T_a=25^{\circ}C$ unless otherwise noted)

No.	SYMBOL	PARAMETERS	CONDITIONS	LIMITS			UNITS
				MIN.	TYP.	MAX.	
Comparators C1, C2, C3 and C4.							
C1in, C2in, C3in and C4in pins.							
80	V _{hys}	Input hysteresis		—	17.8	—	mV
81	V _{IL}	Input voltage low		—	—	V _{REF2} -23mV	V
82	V _{IH}	Input voltage high		V _{REF2} +10mV	—	—	V
83	I _{IL}	Input current low	C1in=C2in=C3in=C4in=0V	-1	—	—	μA
84	I _{IH}	Input current high	C1in=C2in=C3in=C4in=V _{cc2}	—	—	1	μA
C1out, C2out, C3out and C4out pins							
85	R	internal resistor	C2out, C3out and C4out pins	8K	10K	12K	Ω
			C1out pin	4K	5K	6K	Ω
86	V _{OL}	Output voltage low	Load current 2mA	—	—	1.0	V
87	t _{tr}		V _{in} =100mVp-p. Inputs connected to via 10kΩ Output connected to V _{cc2} via a 2.5kΩ	—	0.03	0.5	μS

13.CONFIRMED PARAMERTES AT ES EVALUATION

No.	SYMBOL	PARAMETERS	CONDITIONS	LIMITS			UNITS
				MIN.	TYP.	MAX.	
PG Circuit							
1	-VIAMP	Input comparator hysteresis		4	8	14	mV
Thermal protection							
2	TSD	Protection temperature		135	150	165	°C
3	ΔT	Temperature hysteresis		—	30	—	°C

This devise does not guarantee the electrical function above TSD function temperature range.

The function is guaranteed under maximum junction temperature that is regulated in the Absolute Maximum Rating, so TSD function is a protection circuit for unusual Tj when this devise is used over Tj 150°C.

Therefore, this devise must function under Tj maximum 150°C condition.

<Recommend condition>

Minimum temperature of TSD is 135°C.

Therefore, the IC has to be worked by less than 135 °C.

TITLE SPECIFICATION	SPEC. NO. GNOK - M63100BFP - 30	REV. *	PAGE 12/24
------------------------	------------------------------------	-----------	---------------

14. Recommend applications

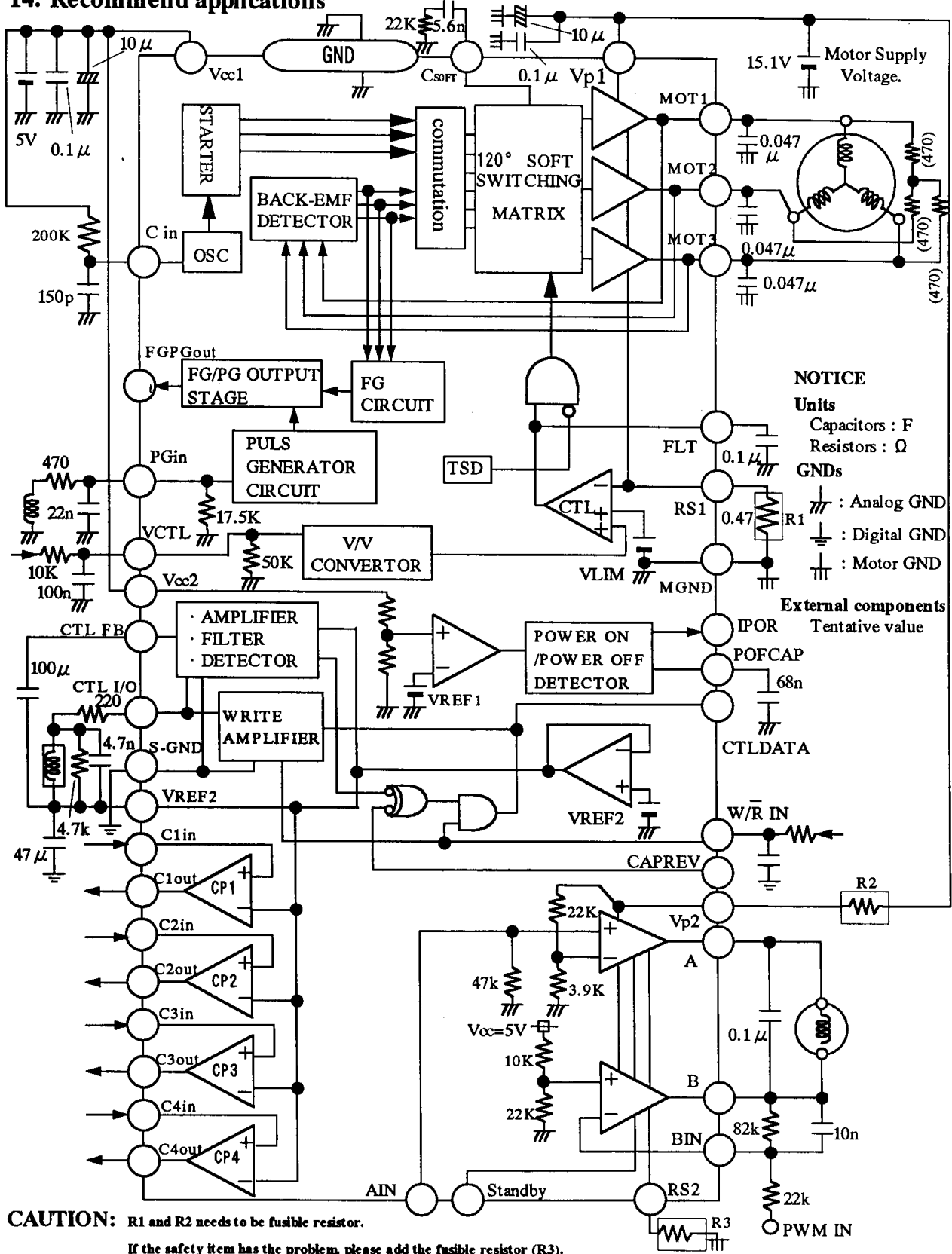

NOTICE
 Units
 Capacitors : F
 Resistors : Ω
 GNDs
 [Symbol] : Analog GND
 [Symbol] : Digital GND
 [Symbol] : Motor GND

External components
 Tentative value

CAUTION: R1 and R2 needs to be fusible resistor.
 If the safety item has the problem, please add the fusible resistor (R3).

15. Commutation and FGPG signal output timing chart

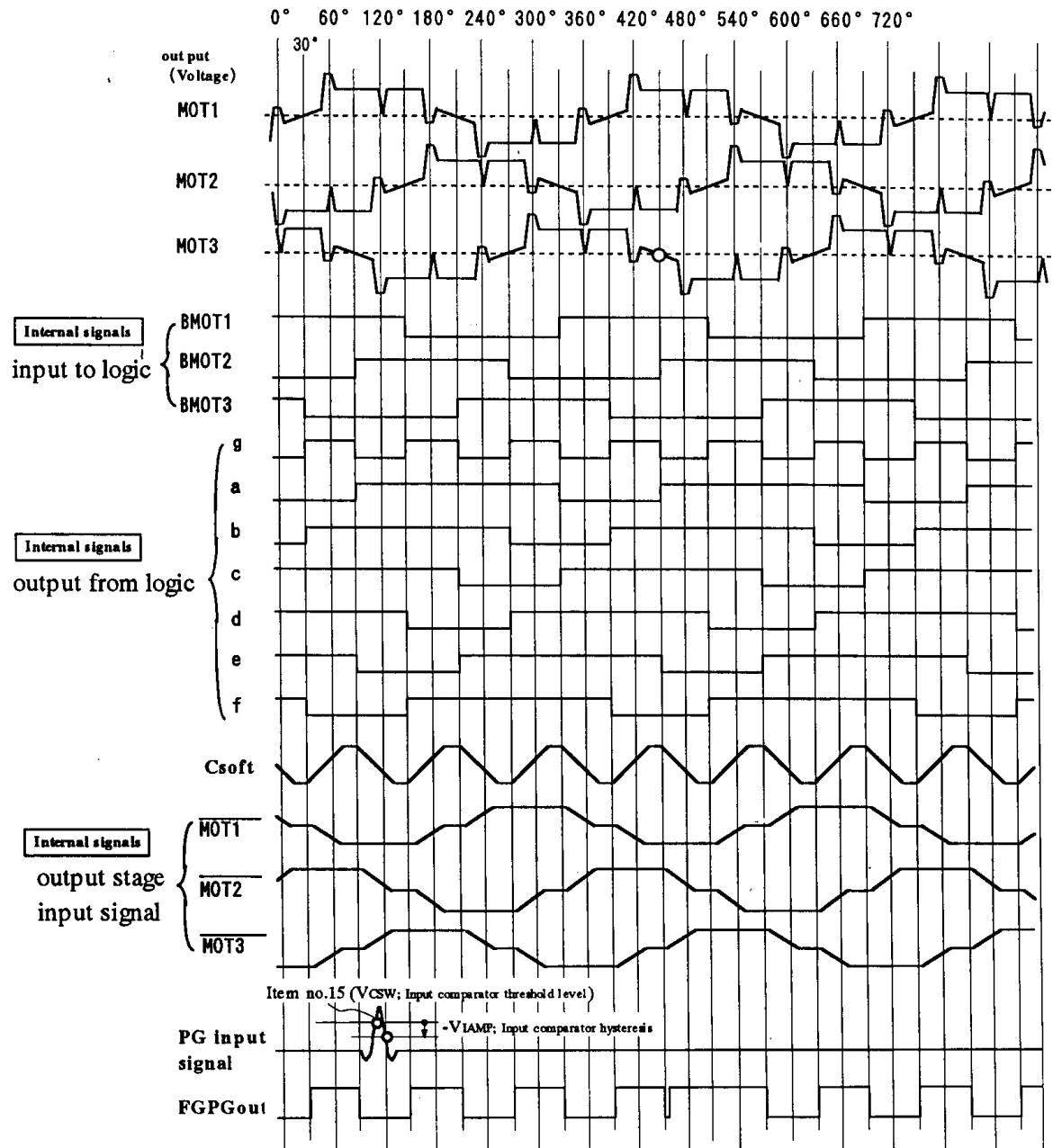

16. Interface Circuit

TERMINAL	SYMBOL	INTERFACE CIRCUIT	TERMINAL FUNCTION
13	Cin		This terminal is connected a capacitor for oscillation. And, this oscillation frequency is used for internal clock.
34	C1out		Outputs of Comparator CP1, CP2, CP3 and CP4.
33	C2out		
31	C3out		
30	C4out		
39	C1in		Inputs of Comparators CP1, CP2, CP3 and CP4.
38	C2in		
37	C3in		
35	C4in		
11	VCTL		Drum motor speed control
15	MGND		Motor GND.
3	CTLIO		The head amplifier input and feedback function terminal.
2	CTLFB		

TERMINAL	SYMBOL	INTERFACE CIRCUIT	TERMINAL FUNCTION
4	VREF2	<p>4pin(VREF2); R=230ohm 28pin(IPOR); R=180ohm</p>	VREF2 output.
28	IPOR		Power On Reset Fail output
27	AIN	<p>2K 47K</p>	Input AIN of Loading Motor Amp. A.
26	Standby	<p>2K 20K 2.5V Loading motor parts bias current</p>	Input standby signal
22	A	<p>Vp2 RS2</p>	Out A of Loading Motor drive.
24	B		Out B of Loading Motor drive.
23	RS2		
5	CAPREV	<p>Vcc2 2K</p>	Capstan reverse command input.
40	W/R IN		Write / Read Command input.

TERMINAL	SYMBOL	INTERFACE CIRCUIT	TERMINAL FUNCTION
41	CTLDATA		Control head data output
29	POFCAP		The capacitor for POR timing set.
19	MOT1		Phase 1 of Drum Motor drive
18	MOT2		Phase 2 of Drum Motor drive
16	MOT3		Phase 3 of Drum Motor drive
17	RS1		Motor current output
9	FLT		Current feedback amp. output
7	Csoft		Capacitor for soft switching

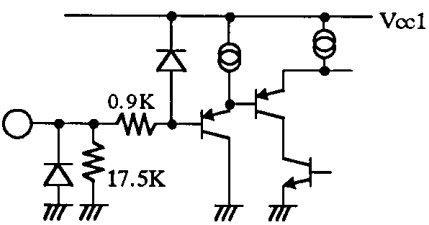
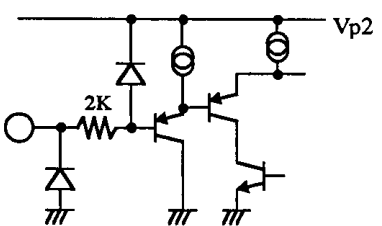
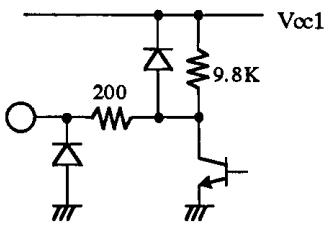
TERMINAL	SYMBOL	INTERFACE CIRCUIT	TERMINAL FUNCTION
8	PGin		PG signal input.
25	BIN		Inverting input of Loading Motor drive amp. B.
6	FGPGout		Combined FG and PG signal output.

17. TECHNICAL MANUAL

(1) Drum Motor Driver

A) The timing chart-1 : The initial drum motor start.

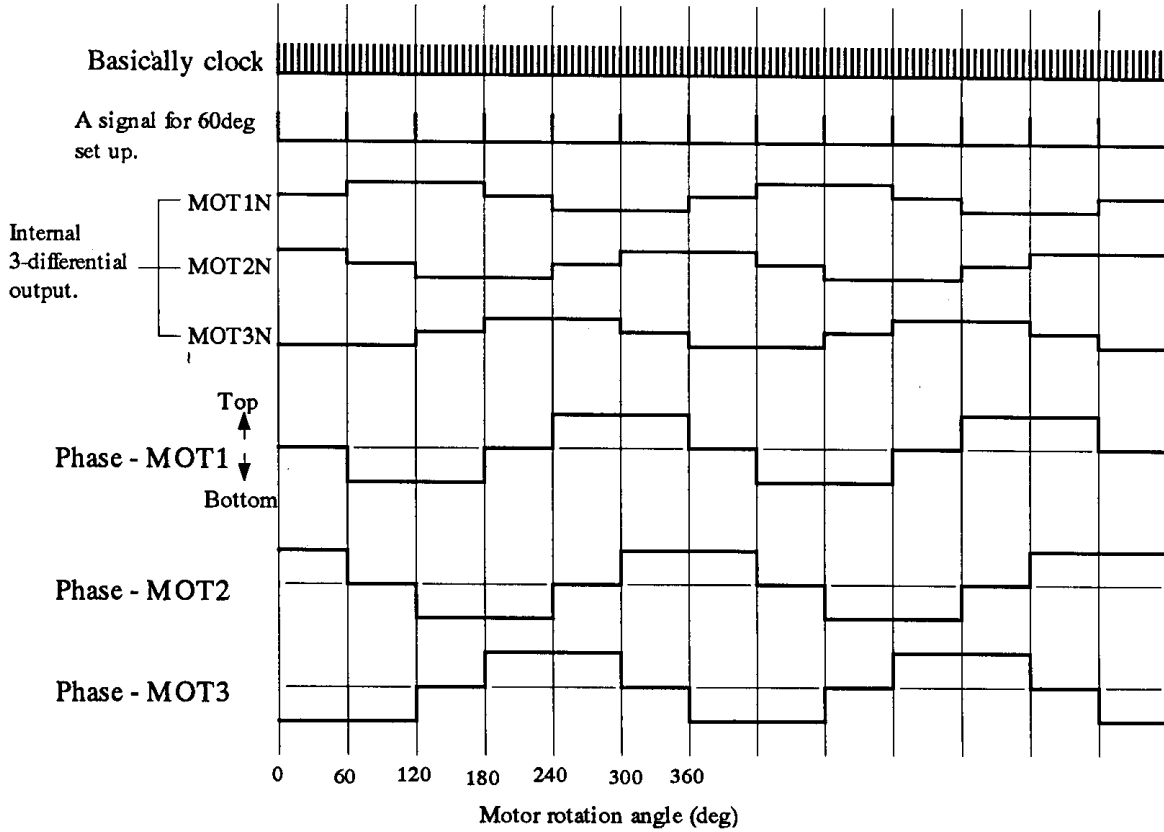

B) The timing chart-2 : The initial drum motor start.

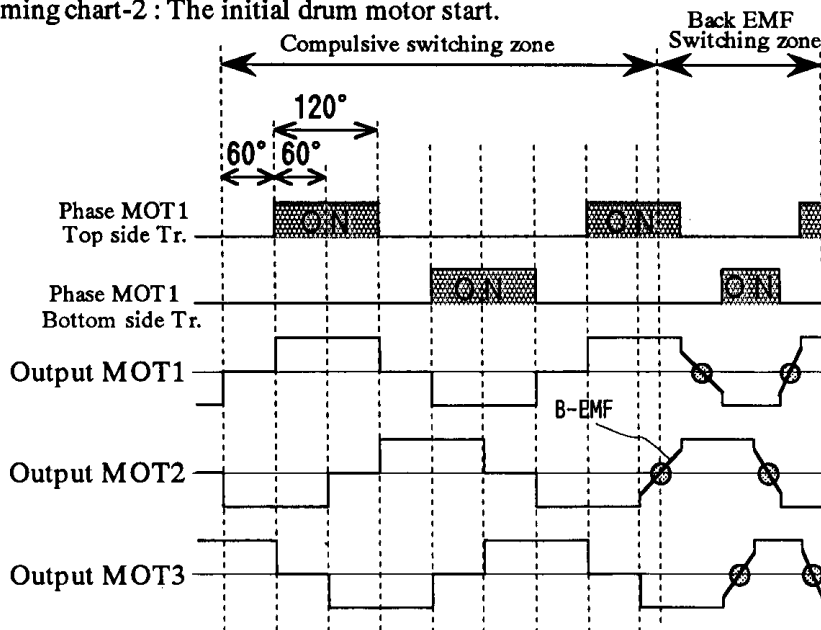

(2) Motor Start up and reverse protection.

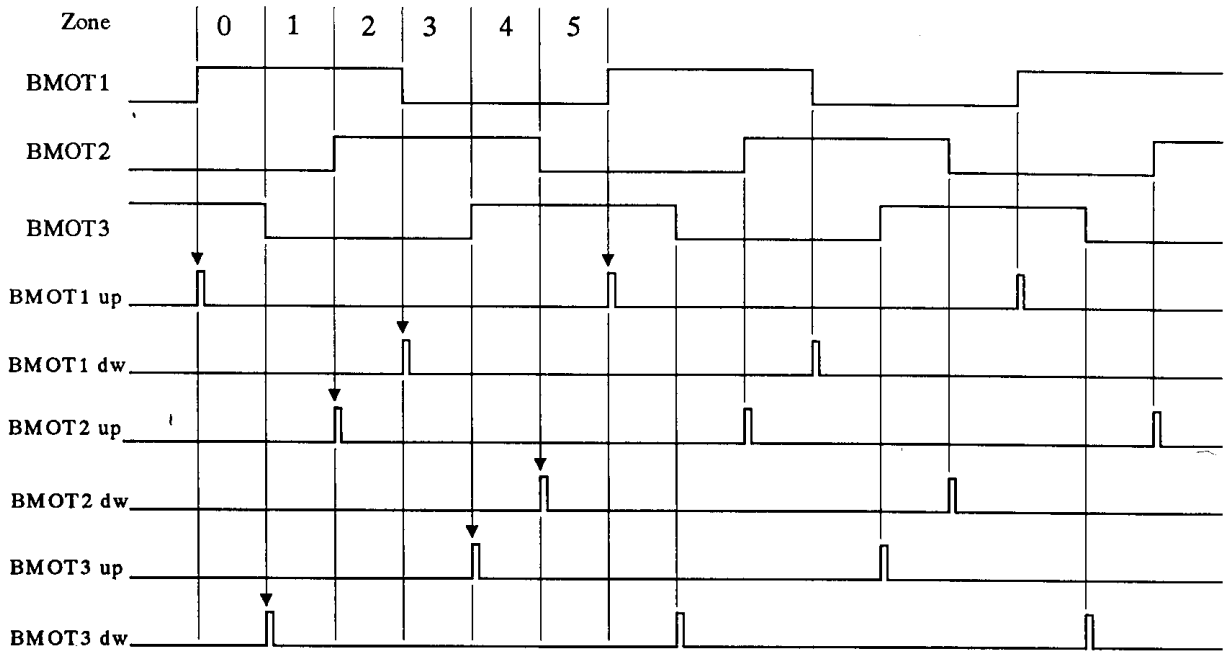

Figure 1. Motor start up and reverse protection.

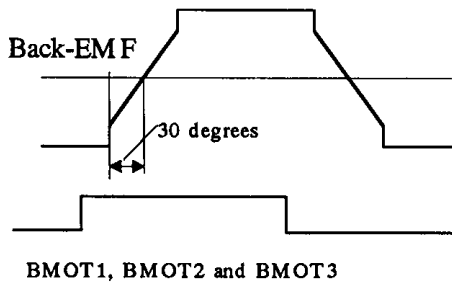

Figure 2. Comprated signal from B-EMF

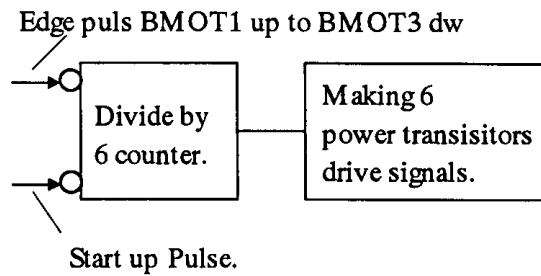

Figure 3. Motor reverse protection.

Position detect signals			Divide by 6 counter.			Zone
BMOT1	BMOT2	BMOT3	Counter 1	Counter 2	Counter 3	
H	L	H	L	L	L	0
H	L	L	H	L	L	1
H	H	L	H	H	L	2
L	H	L	H	H	H	3
L	H	H	L	H	H	4
L	L	H	L	L	H	5

Table 1. Devide by six counter logic table.

Back EMF are compared with a zero cross and the phase of these signals must be pushed forward 30 degrees for the switching signal of motor drive.
So, these signals are called BMOT1, BMOT2 and BMOT3 in Figure 2.

<Sequence>

In the 60 degrees zone in 360 degrees motor rotation, the timing of BMOT1, BMOT2 and BMOT3 are decided in each six zone. (Please see the table.1 (19/23)page)

For example,

(1) If the logic of (BMOT1, BMOT2, BMOT3) is (H, L, H), the zone is "0".

(2) If the logic of (BMOT1, BMOT2, BMOT3) is (H, L, L), the zone is "1".

If the order is kept as "0" → "1" → "2" → "3" → "4" → "5", the motor rotate is normally.

(3) For example, the motor is driven by the compulsive pulse(start-up pulse) as shown in zone 0.

(4) Next, the motor is driven by the switched signal as 0 → 1

(5) Six divide counters always check the timing of 0 → 1 → 2 → 3 → 4 → 5 by the edge pulse of MOT1, MOT2, MOT3-up or MOT1, MOT2, MOT3-down.

(6) And, if the order is mistake(0 → 5 → 4), IC move to restart-up mode.

(3) Basically formula for Drum motor driver

(1) $N = (40 * \text{FG frequency} < \text{Hz} >) / \text{pole}$

(2) Start-up time $< 60^\circ > = (1/f_{\text{CLK}}) * 128 * 12$

(3) $T_{\text{mask1} < \text{min} >} = (1/f_{\text{CLK}}) * 4 * 18 + (1/f_{\text{CLK}}) * 2 = (1/f_{\text{CLK}}) * (4 * 18 + 2)$

$T_{\text{mask1} < \text{max} >} = (1/f_{\text{CLK}}) * 4 * 19 + (1/f_{\text{CLK}}) * 4 = (1/f_{\text{CLK}}) * 4 * 20$

(4) $T_{\text{mask2} < \text{min} >} = (1/f_{\text{CLK}}) * 2 * 15 + (1/f_{\text{CLK}}) * 2 = (1/f_{\text{CLK}}) * 2 * 16$

$T_{\text{mask2} < \text{max} >} = (1/f_{\text{CLK}}) * 2 * 16 + (1/f_{\text{CLK}}) * 4 = (1/f_{\text{CLK}}) * 2 * 18$

Remark;

Tmask1; Masking time for drum motor spaiick noise befor IC does not detect PG pulse.

Tmask2; Masking time for drum motor spaiick noise after IC detected PG pulse.

(4) Read/Write circuit.

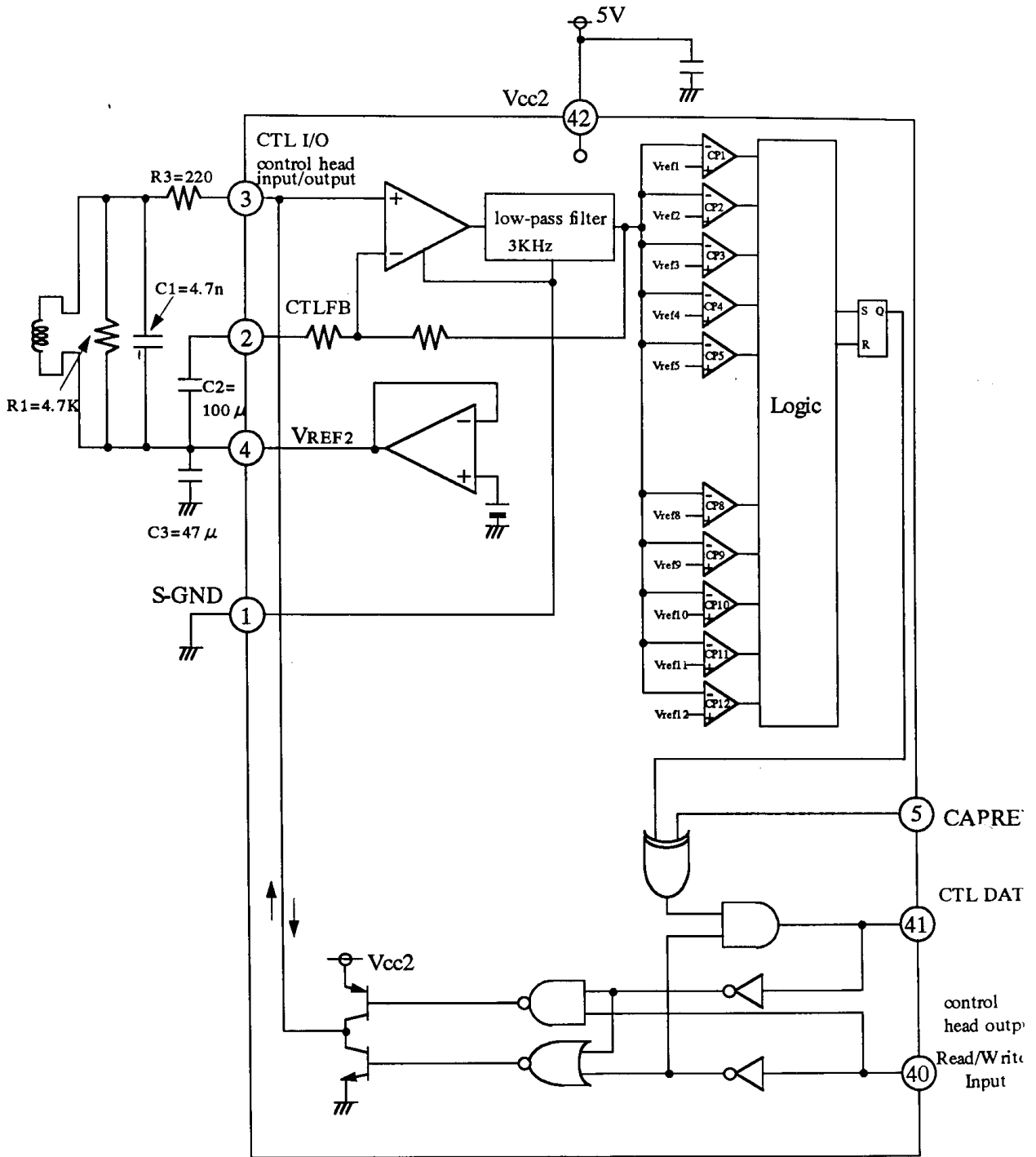

Units : R=Ω, C=F

TITLE	SPEC. NO.	REV.	PAGE
SPECIFICATION	GNOK - M63100BFP - 30	*	22/24

(5) IPOR Function.

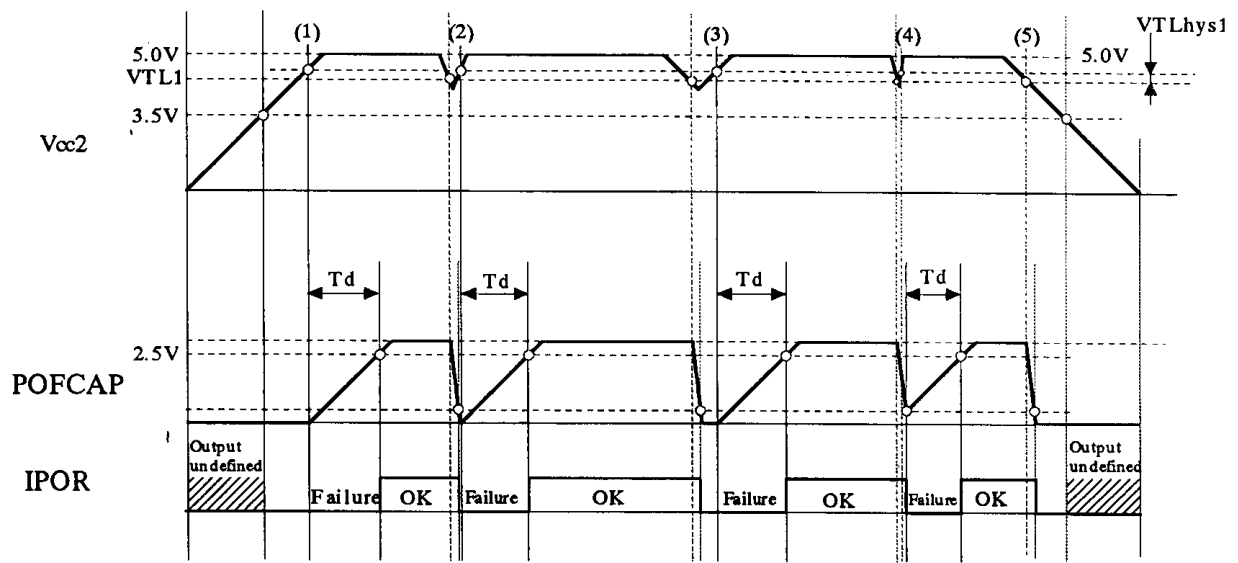

(6) Time error calculation for drum motor part

Influences from IC(M63100BFP)

- (1) B-EMF detection circuits ----- $\pm 1.40\mu S$
 - (2) V_{ctl} gain (tolerance $0.236 \sim 0.279 < A/V >$) ----- $\pm 0.1\mu S$ (evaluation result)
 - (3) Influence supply voltage V_p ----- $\pm 0.83\mu S$ (at $0.2V_{p-p}$ ripple)
 $\pm 1.66\mu S$ (at $0.4V_{p-p}$ ripple)
-
- Total <worst case> $\pm 2.33\mu S$ (at $0.2V_{p-p}$ ripple)
 $\pm 3.16\mu S$ (at $0.4V_{p-p}$ ripple)

(7) B-EMF circuits time error measuring conditions

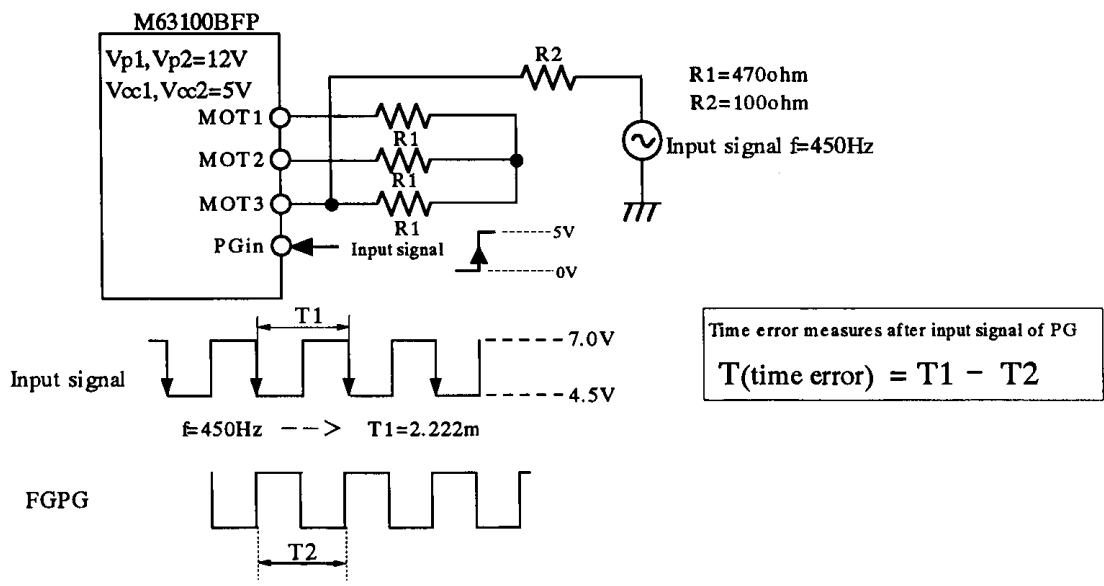

(8) Recommend start up timing for Drum motor

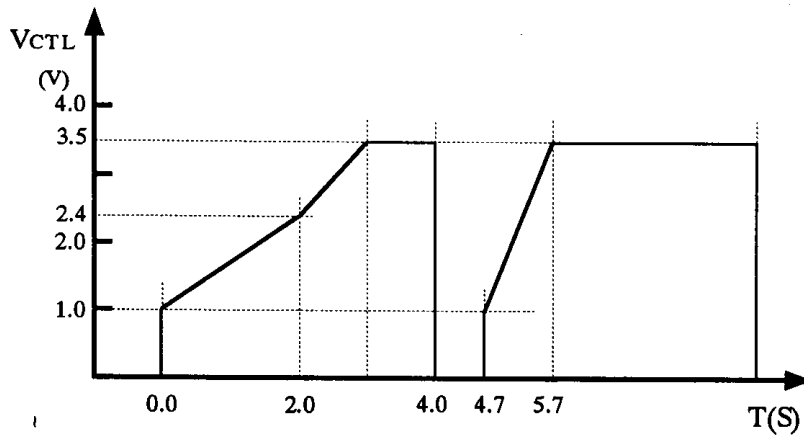

(9) CTL I/O characteristics test conditions

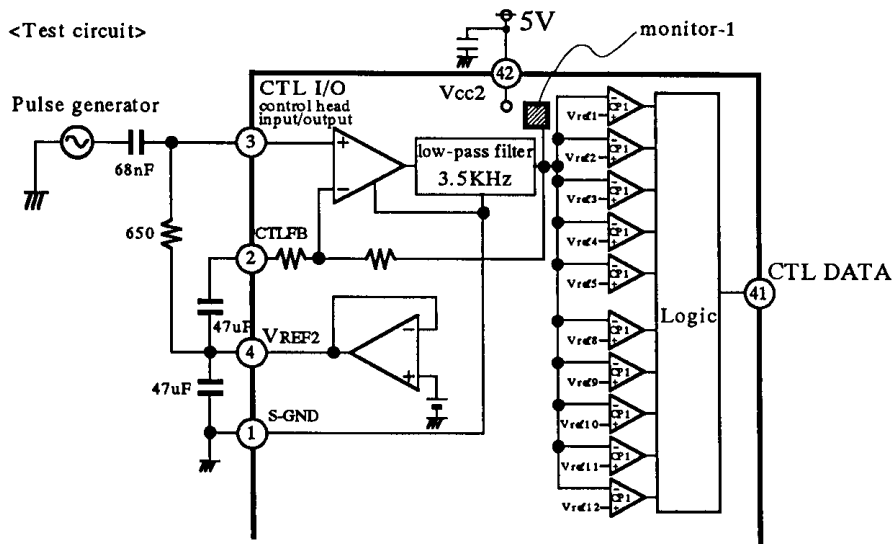

(1) Item No.46

Input conditions (pulse generator): $V=5mV_{pp}$, $f=1KHz$
 The measurement terminal: monitor-1

(2) Item No.42

At first, we input pulse from monitor terminal.

Input pulses: $V=(V1)mV_{pp}$, $f=500Hz$

We check the CTL DATA.

If CTL DATA appears the pulses, V_{inCTL1} (item no.42) is as follows.

$$V_{inCTL1} = \frac{(V1)mV_{pp}}{\text{Gain}(\text{item no.46})}$$