



28 VDC SOLID-STATE POWER CONTROLLERS



DESCRIPTION

The RP-21000 Series (formerly SSP-21110 Series) of 28 Vdc, Solid-State Power Controllers (SSPCs) replace electromagnetic circuit breakers and solid-state relays rated from 2 through 25 amperes. These SSPCs offer status outputs and permit external input logic control so that they may be remotely located near to the load. There are five models in the series, differing only in rated current, so that fault and I²T trip characteristics can be selected to protect wiring and loads.

Using Power MOSFET switches, these Power Controllers offer low "on" resistance, low voltage drop, high "off" impedance, and low power dissipation. Built with Power MOSFETs and custom monolithics and using thick-film hybrid technology, they offer small size, low power, and high reliability.

Built-In-Test (BIT) has been provided to monitor, in real time, the status of the internal circuitry as well as circuitry external to the SSPC. This BIT monitors MOSFET failure and control circuit failure. The RP-21000 Series will operate over the full MIL temperature range from -55°C to +125°C with no thermal derating. See ordering information for more details.

APPLICATIONS

Designed to replace circuit breakers in land, air, and space vehicles, these Solid-State Power Controllers provide status outputs for light and heavy overloads as well as minimum load current.

FEATURES

- Available in 2, 5, 10, 15, 20 and 25 Amp Ratings
- True I²T Protection
- Compliant to MIL-STD-704 and MIL-H-38534
- Isolated Control Circuitry
- Status Outputs
- Instant Trip Protection
- No Thermal Derating
- Low Power Dissipation
- Solid-State Reliability

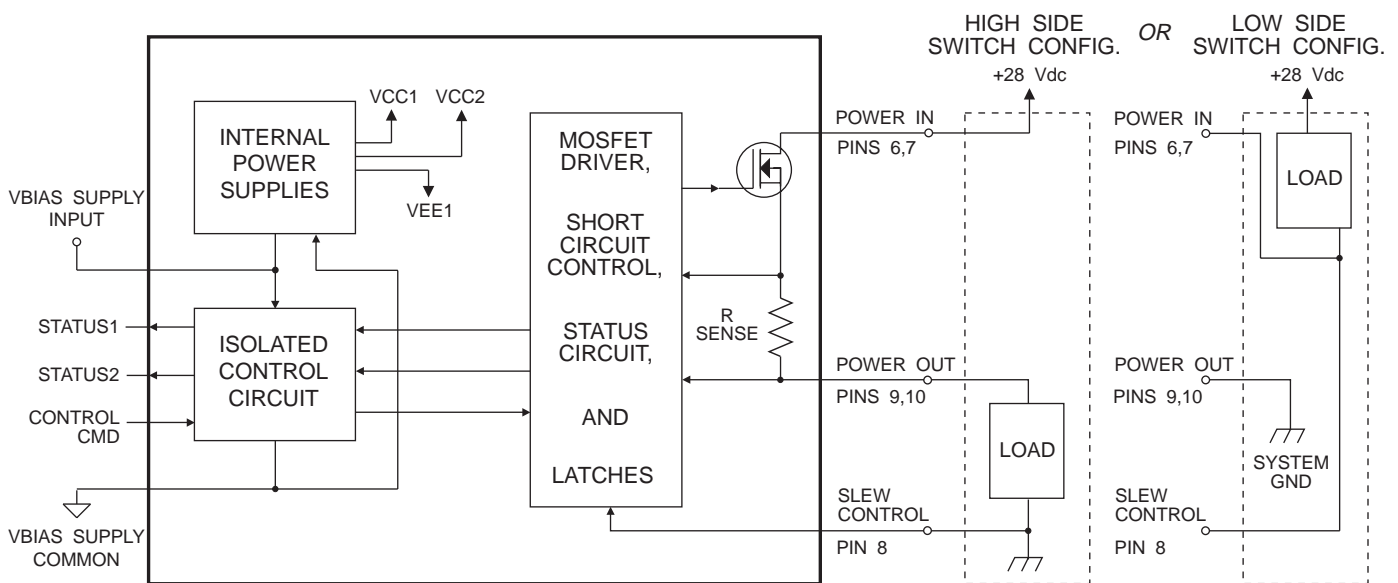

FIGURE 1. RP-21000 SERIES BLOCK DIAGRAM

PARAMETER	UNIT	VALUE
Power In to Power Out	Vdc	50 continuous 100 Volts, 50 ms transient
Power Out to Slew Control	Vdc	50 continuous
Control Input to Signal Ground	Vdc	-0.5 to VBias +0.5
Power Out to Signal Ground	Vdc	-100 to +100
VBias Voltage (see note 4)	Vdc	-0.5 to +7.0
Pin-to-Case	Vdc	-1000 to +1000
Lead Temperature (soldering)	°C	+300 (within 10 sec.)
Junction Temperature	°C	+150

PARAMETER	UNIT	VALUE
Power In to Power Out	Vdc	+9.0 to +40.0
Control Input to Signal Ground	Vdc	+4.5 to VBias
Power Out to Signal Ground	Vdc	-40 to +40
VBias voltage (see note 4)	Vdc	+4.5 to +5.5

PARAMETER	CONDITIONS	UNIT	VALUE
CONTROL CIRCUIT			
Logic Type	Note 3		TTL/CMOS compatible
VBias Supply Current	VCC = 4.5 to 5.5 Vdc	mA	30 typ 70 max
Control Turn-On Voltage		V	2.0 to 5.5
Control Turn-Off Voltage		V	-0.5 to 0.8
Control Input Current	control voltage = 5.0 V	µA	50 max
Control Input Current	control voltage = 2.4 V	µA	50 max
Control Input Current	control voltage = 0.8 V	µA	-50 min
Status Output Voltage	V _{CC} = 4.5V, I _{OL} = 2.5 mA	V	0.4 max
Status Output Voltage	V _{CC} = 4.5V, I _{OH} = -1.0mA	V	2.4 min
Status Truth Table	see TABLE 5		
POWER CIRCUIT			
Max. Continuous Current			See TABLE 4
"On" Resistance			See TABLE 4
Power Dissipation			See TABLE 4
Power Input Leakage Current to Power Out	Power In = 9 - 40 V (see note 2)	mA/A	0.1 max
Max Load Capacitance for Start-Up	Power In = 9 - 40 V (see note 2)	µF/A	36 typ
Signal Ground to Power Out Isolation	at 100 Vdc	pF	1000 typ
Output Capacitance	see note 2	pF/A	300 typ
Trip Reset Time		ms	30 min
Rupture Capacity	Unlimited	A	Unlimited
Output-to-Input Parasitic Diode, Continuous Current Per Amp Of Rated Current	Power Out Voltage > Power In Voltage	A	1.0 typ

PARAMETER	CONDITIONS	UNIT	VALUE
POWER CIRCUIT (continued)			
Output-to-Input Parasitic Diode, Pulsed Current Per Amp Of Rated Current	Power Out Voltage > Power In Voltage Pulse Width ≤ 100µS	A	4.0 typ
Output-to-Input Parasitic Diode, Forward Voltage at Continuous Current	Power Out Voltage > Power In Voltage	V	1.8 max
Isolation Resistance Any Pin to Case	Pin-to-Case Voltage = 100Vdc	MΩ	50 min
Isolation Resistance Power Out to Signal Ground	Power Ground to Signal Ground Voltage = 50Vdc	MΩ	50 min
Voltage Drop	across pins 6&7, 9&10	Vdc	0.25 max
Trip Characteristics	see FIGURE 2		
Response Time	see FIGURE 3		
TEMPERATURE RANGE			
Operating (Case)		°C	-55 to +125
Storage		°C	-55 to +150
THERMAL RESISTANCE			
Case to Sink (θ _{CS})		°C/W	0.5
Case to Ambient (θ _{CA})		°C/W	12
Temperature Rise, Junction-to-Case	Rated Load	°C	10
PHYSICAL CHARACTERISTICS			
Size Weight	See FIGURE 4	g	65 max

- Notes:
1. -55°C ≤ Case Temperature ≤ 125°C.
2. 'A' is Amps of Rated SSPC Current.
3. Control Input must never be left floating.
4. An external 0.1µf ceramic capacitor from VBias to the +5V return ground is recommended.

PART NUMBER	I-MAX* (Amps)	"ON" RESISTANCE (Ohms)**	POWER DISSIPATION (Watts)**
RP-21002	2	0.1	0.6
RP-21005	5	0.03	1.6
RP-21010	10	0.023	2.6
RP-21015	15	0.015	3.5
RP-21020	20	0.012	5.0
RP-21025	25	0.012	7.7

- * I-MAX is the maximum continuous current.
** Specified for -55° to +105°C case temperature; Please increase by 0.6%/°C between +105°C and +125°C Max Limit.

FUNCTIONAL DESCRIPTION

The RP-21000 series of Solid-State Power Controllers incorporate the wire protection feature of electromechanical circuit breakers and the reliability of solid-state relays. In addition to the solid-state relay's input logic compatibility, the RP-21000 series provide logic compatible status outputs.

A TTL/CMOS compatible input provides external control of the power switch's "ON/OFF" state. A logic high on this control input turns the power to the load "on." A logic low will turn the power switch off, which removes power from the load.

In the event of an overload the RP-21000 series will trip, just like a circuit breaker, and automatically remove power from the load. In order to turn back on the control input must be brought to a logic low, and then returned to a logic high state.

As in a circuit breaker, the SSPC's time to trip depends on the current level. Slight overloads will cause longer trip times. Heavy overloads will cause shorter trip times. The fault ("Instant Trip") and I²T trip curve (see FIGURE 2) shows the trip time as a function of current for a single trip or repetitive trips with at least 10 seconds between trip and turn on. Attempts to repeatedly turn on into an overload will result in the thermal memory shortening each trip time. This "memory" protects the wire, load and Solid-State Power Controller.

The status lines are TTL/CMOS compatible outputs which reflect the state of the SSPC, the load, and the Built-In-Test (BIT) circuits. The status permits an external subsystem to monitor and ultimately control the SSPC. TABLE 5 defines the status lines'

states which indicate the various states of the SSPC. Further explanation of the status lines appears in the applications information section.

The RP-21000 series SSPCs are characterized by their current rating and maximum "on" resistance listed in TABLE 4. These parameters are established by the number of Power FETs placed in parallel within the SSPC.

The trip function is implemented by two separate circuits, a true I²T trip comparator and a short circuit fault comparator. They are independent of each other but work together to protect the system.

If the load current is less than 110% of rated current, the SSPC will never trip. If the load current is greater than 145%, the SSPC will always trip.

For load currents less than 800%, the trip time can be found from FIGURE 2 by drawing a horizontal line on FIGURE 2 at the current level of interest. The SSPC will always trip at a time between the two curves. This is true I²T tripping.

When the SSPC trips in accordance with the I²T characteristics, the fall time is 200 μs, maximum.

For load currents greater than 1200%, the SSPC will turn off in less than 25 μs. Between 800% and 1200%, the SSPC will turn off in a time less than the "max. trip limit" shown in FIGURE 2 and may turn off in less than 25 μs. When the SSPC turns off under these fault conditions, the fall time is less than 25 μs.

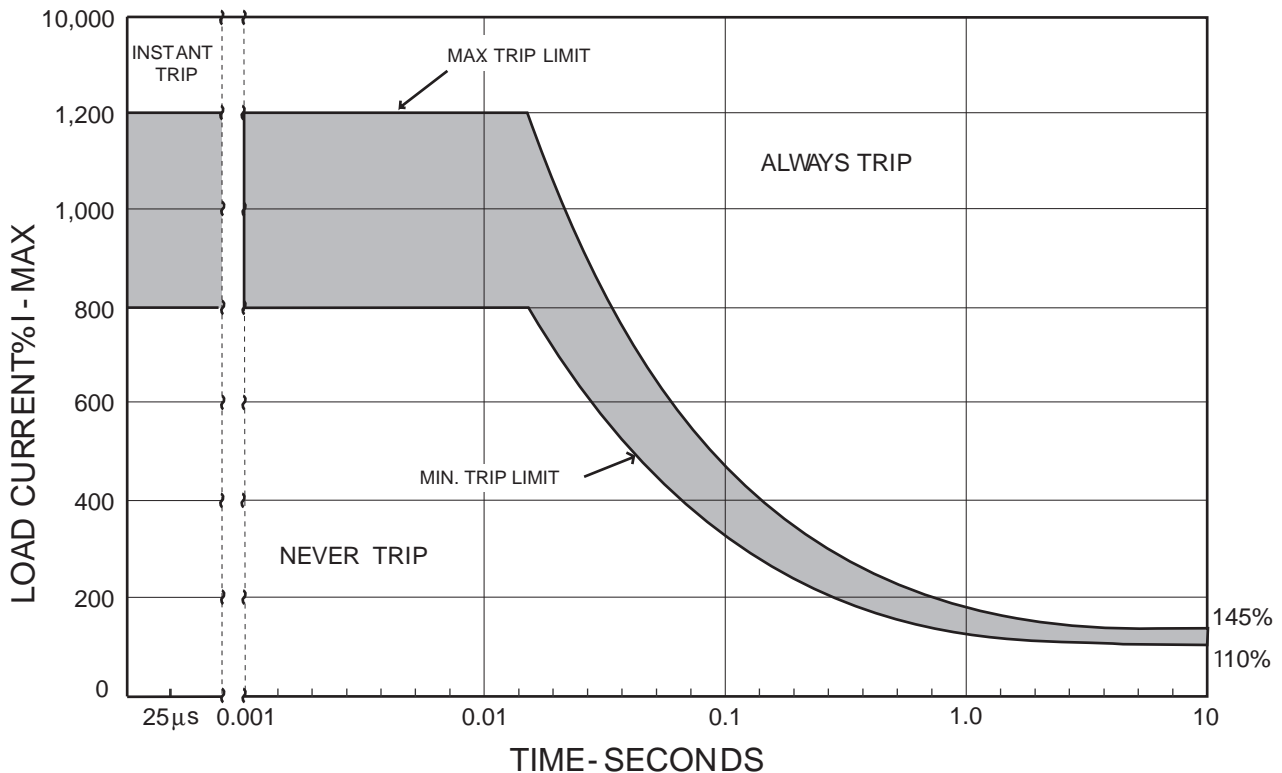

FIGURE 2. TRIP CHARACTERISTICS

While the SSPC will always turn off in less than 25 μs when the load current is greater than 1200%, the actual current may "spike" to a value higher than 1200% due to circuit delays. The MOSFETs inherently self-limit the maximum current, depending on the number of MOSFETs and their rating.

During turn-on and turn-off the rise and fall time of the output voltage is controlled to be less than 200 μs . This value is a compromise between faster response time with a greater amount of RFI and EMI generated, and slower response time with less RFI and EMI but greater power dissipated in the SSPC during transitions. Since the Power MOSFET switches are not saturated during transitions, the switching power dissipation is much greater than the static dissipation, and longer transitions result in a larger temperature rise. If the SSPC is rapidly turned on and off, the high average dissipation could result in a significant temperature rise in the SSPC. For this reason do not turn the SSPC off and on more rapidly than 30 msec. This will limit the maximum temperature of the switches to a safe level.

The RP-21000 has been designed to derive its internal power requirements from the bias supply input (+5 Vdc).

APPLICATIONS INFORMATION

In some applications, low side switching will be required as shown in FIGURE 1. In this configuration the load is being switched through to system ground. The external 28 Vdc is connected directly to the load while the return is connected to Pins 9 and 10, which are the Power Out pins. The Slew Control (Pin 8) is connected to maintain a controlled turn-on and turn-off of the load current.

SELECTION

The selection of a proper sized SSPC is essential for protection of the wire and load. This selection should be based on the steady state and transient overload currents.

The shape of the trip curve (I^2T) is selected as optimum to protect the system wiring. The power dissipated in the wire is the wire resistance times the load current squared, and the temperature of the wire is determined by the length of time that this power is being dissipated. This makes the wire temperature proportional to the current squared times the on time. Since the trip curve follows this same characteristic the SSPC can accurately predict the wire temperature rise as a result of overloads and

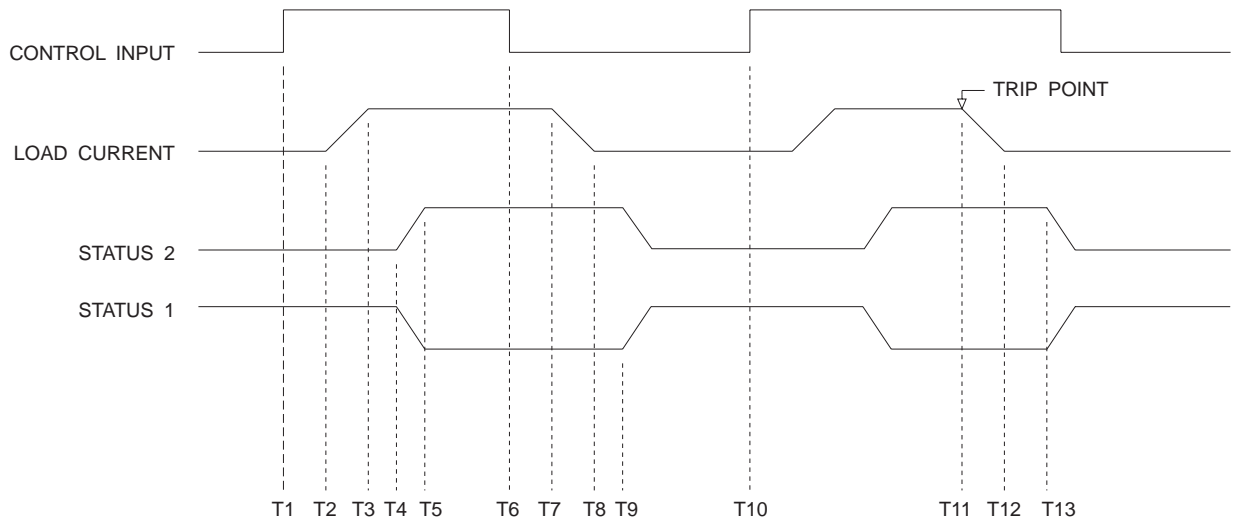

SOLID-STATE POWER CONTROLLER TIMING AT 28 VDC				
TIME	DESCRIPTION	MAXIMUM	UNIT	NOTES
T1-T2	TURN-ON DELAY	350	μs	
T2-3	VOLTAGE RISE TIME	200	μs	*
T1-T4	STATUS 1 & STATUS 2 TURN ON DELAY	7.5	ms	
T4-T5	STATUS 1 & STATUS 2 RISE AND FALL TIME	350	ns	
T6-7	TURN OFF DELAY	350	μs	
T7-T8	VOLTAGE FALL TIME	200	μs	*
T6-T9	STATUS 1 & STATUS 2 TURN OFF DELAY	5.0	ms	
T10-T11	TRIP TIME AFTER TURN-ON	SEE FIG. 2	s	
T11-T12	VOLTAGE FALL TIME AFTER TRIP	200	μs	*LOAD CURRENT < 800%
T11-T12	VOLTAGE FALL TIME AFTER TRIP	25	μs	*LOAD CURRENT > 1200%
T11-T13	TRIP TURN-OFF STATUS 1 DELAY	5.0	ms	

Note: *Voltage rise/fall time is specified for Power In equal to 28 Vdc and is proportional to the Power In voltage.

FIGURE 3. SOLID-STATE POWER CONTROLLER TIMING

remove load current before the wiring is damaged from overtemperature. Of course, the wire I²T product should be greater than the SSPC I²T product for the SSPC to protect the wire.

PRECAUTIONS

When a short-circuit causes turn off of the SSPC, precautions have to be taken to limit the transient voltages generated by the wire inductance. The magnitude of this voltage is $L \cdot di/dt$, where "L" is the wire inductance in Henries and "di/dt" is the rate of change of output current. If the SSPC turns off in 10 μsec from a 250 amp overload (1000% for 25 amp unit) with a wire inductance of only 10 μH, it would generate a spike of 125 volts. This exceeds the voltage rating of the MOSFETs. In order to provide protection from these transients, a transient voltage suppressor should be used between the Power In terminal and Slew Control (Power Ground) and a power diode should be used between the Power Output terminals and Slew Control (Power Ground). (In Low Side Switch Configuration, the power diode is not required). The rating of the transient voltage suppressors should be selected so that at the maximum expected short-circuit current, the transient voltage suppressor voltage drop would not exceed the SSPC voltage rating, and the power to be dissipated can be safely absorbed without transient suppressor failure.

While circuit inductance can cause high voltage transients during turn off, lack of circuit inductance can cause current transients prior to turn off. If the output of the SSPC is shorted and there is no circuit inductance, the current from the source can rise instantaneously to a high value. The SSPC will limit the current to about 100 times its rating (10,000%). Circuit inductance will limit the rate of rise of this current. The SSPC can take 25 μs to turn off. The current will always overshoot the 1200% maximum level of the SSPC due to this 25 μs delay. If the current rises slowly due to circuit inductance the overshoot will be negligible; if the current rises quickly the overshoot will be more significant. In any case, the current spike will be less than 25 μs.

In most real applications there will always be significant circuit inductance. The problem to guard against is voltage transients, not current transients.

When testing individual SSPCs, be careful to simulate actual system conditions.

POWER-ON RESET

When power is first applied the SSPC will be off regardless of the CONTROL CMD input. If the CONTROL CMD input is a logic low the SSPC is turned on by bringing the CONTROL CMD to a logic high. If the CONTROL CMD input is at a logic high when power is applied the SSPC may be turned on by cycling the CONTROL CMD input to a logic low and then to a logic high. The system controller can be programmed to do this cycling of the CONTROL CMD input. Subsequent loss of the bias supply power causes the SSPC to turn off. Re-application of the bias supply power again causes a power-on reset (refer to optional Power-on reset.) Loss of power to the POWER IN terminals does not turn off the SSPC and re-application of this power does not cause a power-on reset.

STATUS CODES

This section contains a fuller explanation of the conditions and meaning of the status codes shown in TABLE 5. Each paragraph number corresponds to the STATE in TABLE 5.

The first four conditions show the control input has commanded the SSPC to be off:

- 1) The SSPC has failed or shorted to ground. STATUS 1 indicates the load is drawing current but the SSPC should be off.
- 2) The SSPC has failed. STATUS 1 indicates the load is drawing current; STATUS 2 indicates the Power MOSFET switch is on; the SSPC should be off.
- 3) Normal off condition. STATUS 1 indicates the load is not drawing current; STATUS 2 indicates the Power MOSFET switch is off.
- 4) The SSPC has failed or STATUS 2 has shorted to the bias supply. STATUS 1 indicates the load is not drawing current; STATUS 2 indicates the Power MOSFET is on; the SSPC should be off.

The next four conditions show the control input has commanded the SSPC to be on:

- 5) The SSPC has failed or there is a short to ground on the STATUS 2 output. STATUS 1 indicates the load is drawing current but STATUS 2 indicates the Power MOSFET switch is off.
- 6) Normal on condition. STATUS 1 indicates the load is

TABLE 5. STATUS CODES

STATE	INPUT CONTROL	OUTPUT STATUS 1 (see note 1)	OUTPUT STATUS 2 (see note 2)	POWER CONTROLLER AND LOAD STATUS
1	L	L	L	SSPC failure or short to ground.
2	L	L	H	Load "on"; showing SSPC failure.
3	L	H	L	Load "off"; showing normal "off" condition.
4	L	H	H	SSPC failure or STATUS 2 shorted to bias supply
5	H	L	L	SSPC failure or short to ground on STATUS 2 line.
6	H	L	H	Load "on"; showing normal "on" condition.
7	H	H	L	Load "off"; showing "trip" (see note 3).
8	H	H	H	Normal power out with load < 5% of rated SSPC current.

Notes:

- 1) STATUS 1 indicates a logic low when the load is > 15% of rated SSPC current.
- 2) STATUS 2 indicates a logic high when the Power MOSFET switch is on.
- 3) Any trip condition per FIGURE 2.

drawing current and STATUS 2 indicates the Power MOSFET switch is on.

7) Tripped condition. STATUS 1 indicates the load is not drawing current and STATUS 2 indicates the Power MOSFET switch is off. The SSPC can be turned back on by cycling the input control to a logic low and then back to a logic high. If the excessive load has not been removed, the SSPC will trip again.

8) No load current. STATUS 1 indicates the load is not drawing current; STATUS 2 indicates the Power MOSFET switch is on.

LOADS

The RP-21000 series can be used with any type of load: any combination of inductive, resistive, and capacitive. In addition, they can be used with dc motors and lamps.

Inductive loads require protecting the SSPC against voltage transients. See the section on Precautions above.

Capacitive loads require comparing the load in-rush current to the trip curve of FIGURE 2. The inrush current must be below the minimum trip curve to avoid tripping on the inrush current. The inrush current can be calculated from the voltage rise time by using $i=C*dv/dt$. Use the minimum rise time for calculation. The minimum rise time is 25% of the maximum rise time specified in FIGURE 3.

Capacitive loads can present a discharge problem. The SSPCs use Power MOSFETs as the switching element. The MOSFETs contain a parasitic diode which will be forward biased if the SSPC power output terminal is more positive than the power input terminal. If the 28 Vdc source is turned off while a charge is held on the capacitive load, this diode will turn on and discharge the load through the generator. The SSPC can carry a reverse current equal to its forward current rating, however, the dissipation with reverse current is up to seven times the forward current dissipation for the same current. The user must ensure that the maximum case temperature is not exceeded. The trip circuit will activate for reverse currents, however, the parasitic diode will continue to conduct. When the power input terminals are brought more positive than the power output terminals the power controller will be off.

Incandescent lamps must be treated like capacitive loads for inrush current. Since they do not store charge, they do not present a discharge problem.

DC motors also must be treated like capacitive loads for in-rush current. If they continue rotating when power is removed, reverse current is a possibility due to back EMF. Voltage transients must also be considered when using dc motors as loads on SSPCs.

HEATSINKING

The RP-21000 series are designed so that the junction temperature can never exceed its maximum rating if the case temperature is held to 125°C or less. Heatsinking is recommended to keep the case temperature to 125°C when operating at high ambient temperatures. The SSPCs may be operated at room

temperature without a heat sink. The maximum ambient temperature, T_A , for operation without a heat sink is $125 - P_d \times \theta_{CA}$ (where P_d is the power dissipation from TABLE 4 and θ_{CA} is the thermal resistance from case-to-ambient from TABLE 3).

The same expression is used for finding the maximum ambient temperature with a heat sink except θ_{CA} is now the sum of the thermal resistance from case-to-sink and from sink-to-ambient.

ADVANTAGES OF THE RP-21000 SERIES

NO OFFSET VOLTAGE

The Power MOSFET used in the DDC SSPCs have no inherent voltage offset. The voltage drop across the Power MOSFET is solely dependent on the current flowing through the device and its "ON" resistance.

Bipolar transistors, on the other hand, have an inherent dc offset voltage to which is added a voltage drop proportional to the devices' "ON" resistance and the current flowing through it. It is this inherent offset voltage that is missing from the power MOSFET. The Power MOSFET, in many applications, leads to a lower voltage drop and power dissipation as an SSPC switch. In addition, the Power MOSFET's driver logic requirements are much simpler, especially when multiple MOSFETs are used as in the SSPC product.

NO SECONDARY BREAKDOWN AND PARALLELING SSPCS

A bipolar transistor has a set of current-voltage limits that form an envelope that cannot be exceeded; this is known as the safe operating area of the device. If this envelope is exceeded, local hot spots will occur. These hot spots conduct currents more readily than adjacent cool areas and tend to become hotter. This thermal runaway leads to the ultimate destruction of the device; called secondary breakdown.

The Power MOSFETs have the opposite characteristics from that of thermal runaway in bipolar devices. A local hot-spot will steer current away from itself as its resistance in this area goes up. This results in even current sharing throughout the entire device, thereby eliminating hot-spots. The inherent advantage of not having secondary breakdown is that the entire MOSFET has to exceed its temperature limitations before damage results. This characteristic makes the Power MOSFET more rugged when used for power switching than bipolar devices.

Due to the current sharing aspects of the power MOSFET, they can be placed in parallel and share the load equally. DDC has a standard 28 Vdc 80 AMP power module which uses this technique.

ISOLATION OF CONTROL AND STATUS

The SSPC was designed with isolation between the load power and the five volt control logic input and the status outputs. This is necessary to prevent noise caused by transients or power spikes on the power line from adversely affecting the operation of the

SSPC. Therefore the case, POWER IN, and Control Circuit are all electrically isolated. FIGURE 1 shows this isolation as the "ISOLATED CONTROL CIRCUIT."

The electrical isolation is supported by an internal power oscillator that electrically isolates separate internal power supplies that will power the internal analog and digital monolithics. This isolation prevents load or logic ground loops from affecting the proper operation of the SSPC. The isolation also insures that a fault of the switch (MOSFET) could never propagate back into the SSPC logic or cause damage to the logic side.

OPTIONS

The Following characteristics can be factory modified on special orders:

- I²T TRIP CURVE: K-factor adjustments
- OUTPUT RISE AND FALL TIMES: Turn-off and Turn-on times can be factory modified (e.g., capacitive loads)
- CURRENT RANGE
- POWER-ON RESET: Other options are available
- INPUT CONTROL:
TTL or CMOS or Both with Hysteresis (Schmitt trigger characteristics)
- CUSTOM PACKAGING
- OPTIONAL STATUS TRUTH TABLE (See TABLE 6)

TABLE 6. OPTIONAL STATUS TRUTH TABLE			
CONTROL	STATUS 1	STATUS 2	SYSTEM STATUS
LOW	LOW	LOW	SSPC failure, or Status1 and Status 2 shorted to ground, or No Bias
LOW	LOW	HIGH	SSPC failure or Status1 shorted to ground
LOW	HIGH	LOW	SSPC failure or Status 2 shorted to ground
LOW	HIGH	HIGH	Load is "OFF", Normal Condition
HIGH	LOW	LOW	SSPC failure or Status 2 shorted to ground
HIGH	LOW	HIGH	Load is "ON", Normal Condition
HIGH	HIGH	LOW	Load is "OFF", Tripped
HIGH	HIGH	HIGH	Load is "ON", Load < 5.0% Rated Current
Status 1 indicates a logic LOW if > 15% of the rated current is flowing. Status 2 indicates a logic LOW if the SSPC is tripped due to overcurrent.			

TABLE 7. PINOUTS			
PIN	FUNCTION	PIN	FUNCTION
5	CONTROL COMMAND	6	POWER IN
4	STATUS 1	7	POWER IN
3	STATUS 2	8	SLEW CONTROL
2	VBIAS SUPPLY COMMON	9	POWER OUT
1	VBIAS SUPPLY INPUT	10	POWER OUT

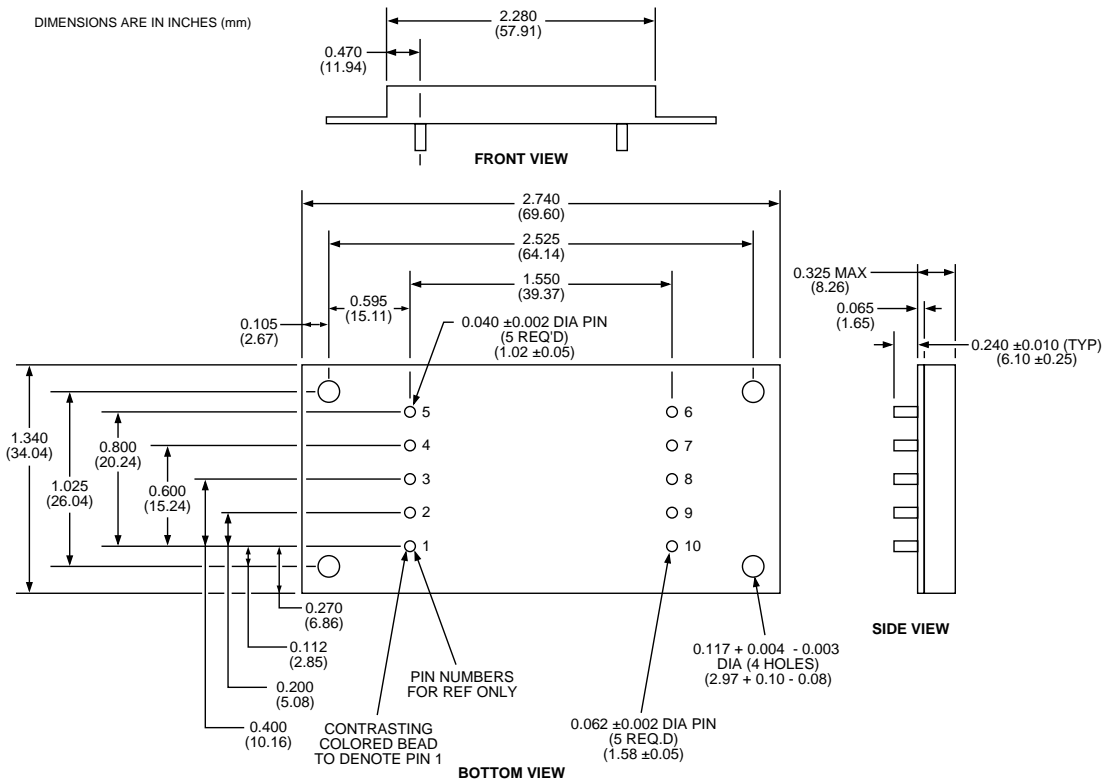
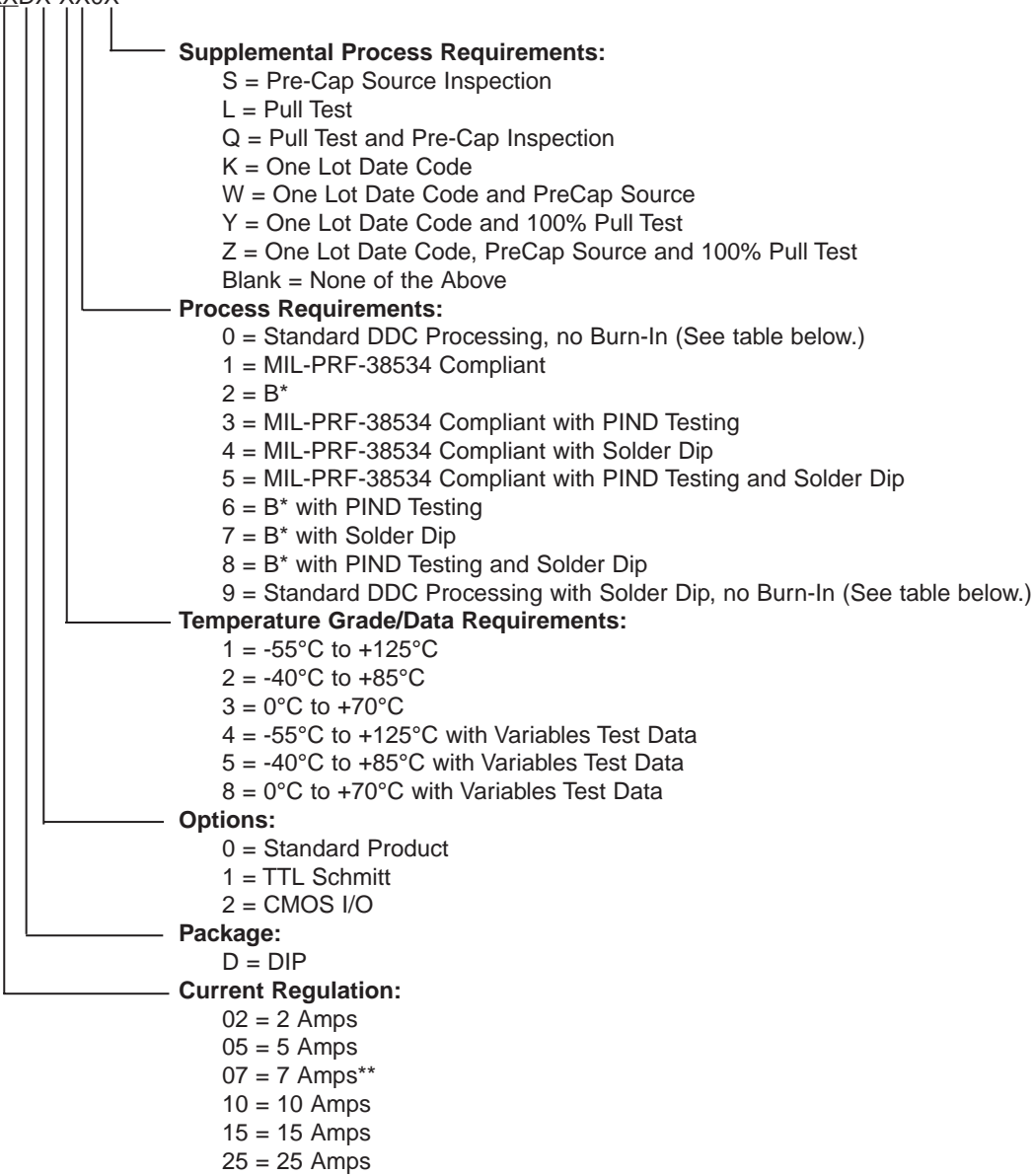

FIGURE 4. MECHANICAL OUTLINE

ORDERING INFORMATION

RP-210XXDX-XX0X



*Standard DDC Processing with burn-in and full temperature test — see table below.

**Contact factory for availability.

STANDARD DDC PROCESSING		
TEST	MIL-STD-883	
	METHOD(S)	CONDITION(S)
INSPECTION	2009, 2010, 2017, and 2032	—
SEAL	1014	A and C
TEMPERATURE CYCLE	1010	C
CONSTANT ACCELERATION	2001	A
BURN-IN	1015, Table 1	—

NOTES

NOTES

The information in this data sheet is believed to be accurate; however, no responsibility is assumed by Data Device Corporation for its use, and no license or rights are granted by implication or otherwise in connection therewith. Specifications are subject to change without notice.



105 Wilbur Place, Bohemia, New York 11716-2482

For Technical Support - 1-800-DDC-5757 ext. 7381

Headquarters - Tel: (631) 567-5600 ext. 7381, Fax: (631) 567-7358

Southeast - Tel: (703) 450-7900, Fax: (703) 450-6610

West Coast - Tel: (714) 895-9777, Fax: (714) 895-4988

Europe - Tel: +44-(0)1635-811140, Fax: +44-(0)1635-32264

Asia/Pacific - Tel: +81-(0)3-3814-7688, Fax: +81-(0)3-3814-7689

World Wide Web - <http://www.ddc-web.com>



ILC DATA DEVICE CORPORATION
REGISTERED TO ISO 9001
FILE NO. A5976