

**SPECIFICATIONS**

**VR 372**

**Mechanical**

**Socket compression force:** 165N min., 372N max.  
**Durability:** 20 Cycles min.  
**Solder Ball Shear Force:** 500g min.

**LGA/BGA power connector**  
**LGA SMT Type**  
**1.27X1.5mm [.05X.06"] Pitch**  
**372 Pos.**

**Electrical**

**Contact Resistance :** 18 mΩ max.  
**Insulation Resistance:** 800mΩ min.  
**Dielectric Withstanding Voltage:** 360V RMS min.

**Physical**

**Housing:** Thermoplastic, UL 94V-0 rated, Black Color  
**Cap:** Thermoplastic, UL 94V-0 rated, Black Color  
**Contact:** Copper Alloy  
**Plating:** See "ORDERING INFORMATION"  
**Operating Temperature:** -55 to +110

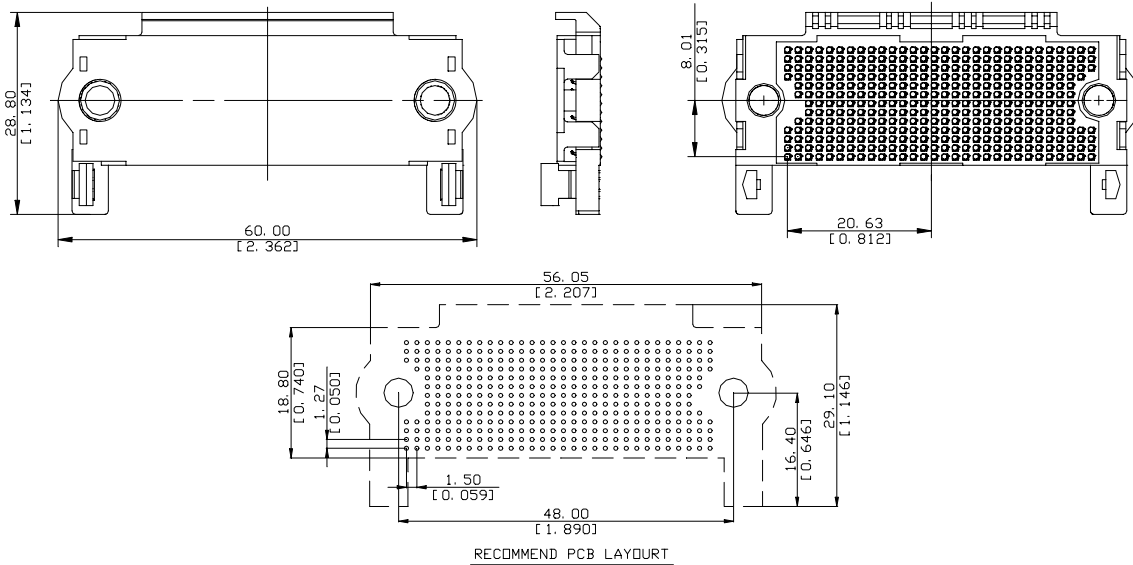
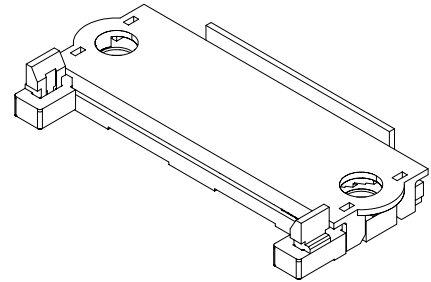

**ORDERING INFORMATION**

**PRODUCT NO.: P E 0 3 7 2 2 3 - 1 3 6 1 - 2 1**

