



U74HCT245

CMOS IC

OCTAL BUS TRANSCEIVERS WITH 3-STATE OUTPUTS

DESCRIPTION

The **U74HCT245** is designed for the asynchronous communication between data buses. While the direction-control(DIR) is high, data transmits from the A bus to the B bus. Data transmits from the B bus to the A bus if DIR is low.

The output-enable(\overline{OE}) will isolate the device from the buses when high voltage is applied on it.

FEATURES

- * Operate from 4.5V to 5.5V
- * Typical t_{PD} is 14ns at 5.5V
- * Inputs are TTL Voltage Compatible

ORDERING INFORMATION

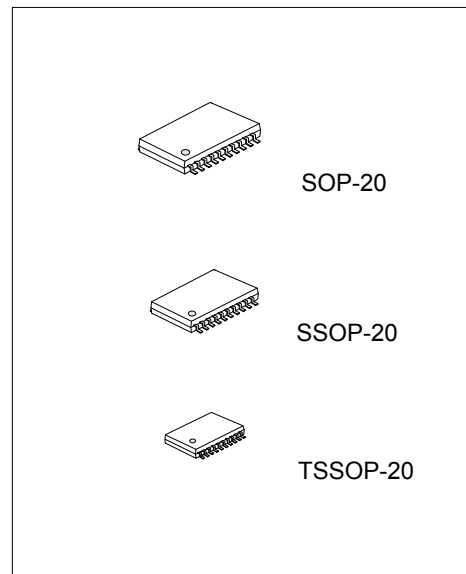

Ordering Number		Package	Packing
Lead Free	Halogen Free		
U74HCT245L-P20-R	U74HCT245G-P20-R	TSSOP-20	Tape Reel
U74HCT245L-P20-T	U74HCT245G-P20-T	TSSOP-20	Tube
U74HCT245L-R20-R	U74HCT245G-R20-R	SSOP-20	Tape Reel
U74HCT245L-R20-T	U74HCT245G-R20-T	SSOP-20	Tube
U74HCT245L-S20-R	U74HCT245G-S20-R	SOP-20	Tape Reel
U74HCT245L-S20-T	U74HCT245G-S20-T	SOP-20	Tube

<p>U74HCT245L-R20-R</p> <p>(1)Packing Type</p> <p>(2)Package Type</p> <p>(3)Lead Free</p>	<p>(1) R: Tape Reel, T: Tube</p> <p>(2) P20: TSSOP-20, R20: SSOP-20, S20: SOP-20</p> <p>(3) G: Halogen Free, L: Lead Free</p>
---	---

■ PIN CONFIGURATION

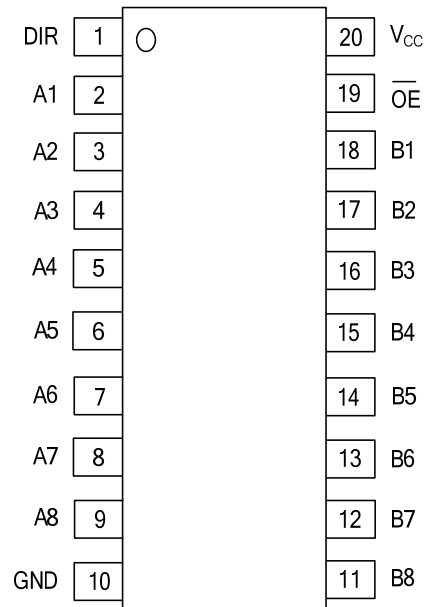

■ FUNCTION TABLE

INPUT		FUNCTION
\overline{OE}	DIR	
H	X	Isolation
L	H	Transmit data from A bus to B bus
L	L	Transmit data from B bus to A bus

Note: H: HIGH voltage level; L: LOW voltage level.

■ LOGIC DIAGRAM

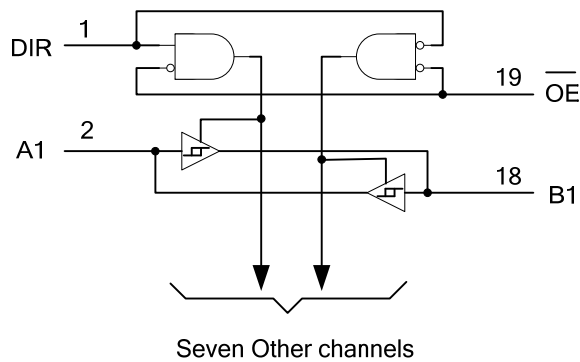

■ ABSOLUTE MAXIMUM RATING

PARAMETER	SYMBOL	RATINGS	UNIT
Supply Voltage	V_{CC}	-0.5~7.0	V
Input Clamp Current ($V_{IN} < 0$)	I_{IK}	± 20	mA
Output Clamp Current ($V_{OUT} < 0$)	I_{OK}	± 20	mA
Output Current	I_{OUT}	± 35	mA
V_{CC} or GND Current	I_{CC}	± 70	mA
Storage Temperature	T_{STG}	-65 ~ +150	°C

Notes: 1. Absolute maximum ratings are those values beyond which the device could be permanently damaged.

Absolute maximum ratings are stress ratings only and functional device operation is not implied.

2. The input and output voltage ratings may be exceeded if the input and output current ratings are observed.

■ RECOMMENDED OPERATING CONDITIONS

PARAMETER	SYMBOL	MIN	TYP	MAX	UNIT
Supply Voltage	V_{CC}	4.5	5	5.5	V
Input Voltage	V_{IN}	0		V_{CC}	V
Output Voltage	V_{OUT}	0		V_{CC}	V
Input Transition Rise or Fall Rate	t_T			500	ns
Operating Temperature	T_{OPR}	-40		85	°C

■ ELECTRICAL CHARACTERISTICS ($T_A=25^\circ\text{C}$, unless otherwise specified)

PARAMETER	SYMBOL	TEST CONDITIONS	MIN	TYP	MAX	UNIT
High-Level input voltage	V_{IH}	$V_{CC}=4.5V\sim 5.5V$	2.0	1.6		V
Low-Level output voltage	V_{OL}	$V_{CC}=4.5V\sim 5.5V$		1.2	0.8	V
High-Level Output Voltage	V_{OH}	$V_{CC}=4.5V, I_{OH}=-20\mu A$	4.4	4.499		V
		$V_{CC}=4.5V, I_{OH}=-6mA$	3.98	4.3		V
Low-Level Output Voltage	V_{OL}	$V_{CC}=4.5V, I_{OL}=20\mu A$		0.001	0.1	V
		$V_{CC}=4.5V, I_{OH}=6mA$		0.17	0.26	V
Input Current of DIR or \overline{OE}	$I_{I(LEAK)}$	$V_{CC}=5.5V, V_{IN}=V_{CC}$ or GND		± 0.1	± 100	nA
Output OFF -state current	I_{OZ}	$V_{CC}=5.5V, V_{OUT}=V_{CC}$ or GND		± 0.01	± 0.5	μA
Quiescent Supply Current	I_{CC}	$V_{CC}=5.5V, V_{IN}=V_{CC}$ or GND, $I_{OUT}=0$			8	μA
Additional Quiescent Supply Current	ΔI_{CC}	$V_{CC}=5.5V$, One input at 0.5V or 2.4V, other inputs at 0 or V_{CC}		1.4	2.4	mA
Input Capacitance of DIR or \overline{OE}	C_{IN}	$V_{CC}=5.5V, V_{IN}=V_{CC}$ or GND		3	10	pF

■ SWITCHING CHARACTERISTICS (T_A=25°C, R_L=1kΩ, unless otherwise specified)

C_L=50pF

PARAMETER	SYMBOL	TEST CONDITIONS	MIN	TYP	MAX	UNIT
Propagation delay from input (A or B) to output (B or A)	t _{PD} (t _{PLH} /t _{PHL})	V _{CC} =4.5V		16	22	ns
		V _{CC} =5.5V		14	20	ns
3-state output enable time from input (\overline{OE}) to output (A or B)	t _{EN} (t _{PZL} /t _{PZH})	V _{CC} =4.5V		25	46	ns
		V _{CC} =5.5V		22	41	ns
3-state output disable time from input (\overline{OE}) to output (A or B)	t _{DIS} (t _{PLZ} /t _{PHZ})	V _{CC} =4.5V		26	40	ns
		V _{CC} =5.5V		23	36	ns
Output transition time, (A or B)	t _T (t _R /t _F)	V _{CC} =4.5V		9	12	ns
		V _{CC} =5.5V		8	11	ns

C_L=150pF

PARAMETER	SYMBOL	TEST CONDITIONS	MIN	TYP	MAX	UNIT
Propagation delay from input (A or B) to output (B or A)	t _{PD} (t _{PLH} /t _{PHL})	V _{CC} =4.5V		20	30	ns
		V _{CC} =5.5V		18	27	ns
3-state output enable time from input (\overline{OE}) to output (A or B)	t _{EN} (t _{PZL} /t _{PZH})	V _{CC} =4.5V		36	59	ns
		V _{CC} =5.5V		30	53	ns
Output transition time, (A or B)	t _T (t _R /t _F)	V _{CC} =4.5V		17	42	ns
		V _{CC} =5.5V		14	38	ns

■ OPERATING CHARACTERISTICS

PARAMETER	SYMBOL	TEST CONDITIONS	RATINGS	UNIT
Power Dissipation Capacitance	C _{PD}	No load	40	pF

TEST CIRCUIT AND WAVEFORMS

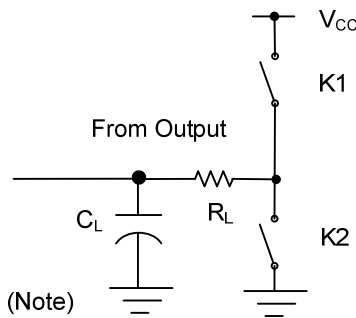

TEST	K1	K2
t_{PLH}/t_{PHL}	Open	Open
t_{PHZ}/t_{PZH}	Open	Close
t_{PLZ}/t_{PZL}	Close	Open

Note: C_L includes probe and jig capacitance.

$$P_{RR} \leq 1\text{MHz}, Z_O = 50\Omega, t_R \leq 6\text{ns}, t_F \leq 6\text{ns}$$

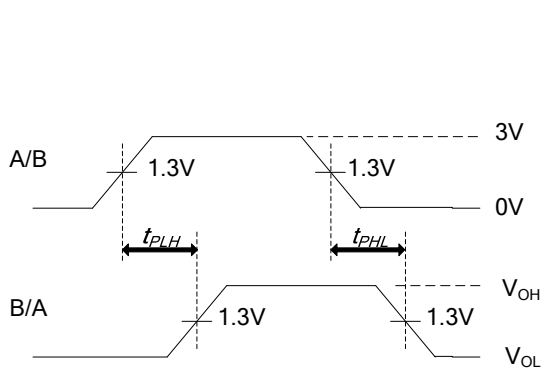

Propagation Delay Times

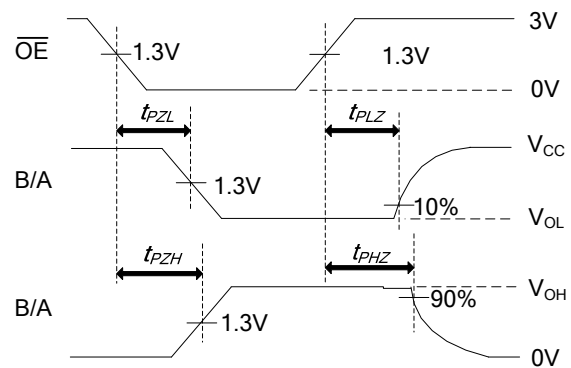

Enable and Disable Times

UTC assumes no responsibility for equipment failures that result from using products at values that exceed, even momentarily, rated values (such as maximum ratings, operating condition ranges, or other parameters) listed in products specifications of any and all UTC products described or contained herein. UTC products are not designed for use in life support appliances, devices or systems where malfunction of these products can be reasonably expected to result in personal injury. Reproduction in whole or in part is prohibited without the prior written consent of the copyright owner. The information presented in this document does not form part of any quotation or contract, is believed to be accurate and reliable and may be changed without notice.