

## Typical Applications

Base Stations  
 Test Equipment  
 Synthesizers  
 Digital Switching

## Features

Surface Mount Package Optional  
 Reflow Process Compatible Optional  
 AT-Cut and SC-Cut Crystal Options  
 Low Profile Compact Package



## Previous Vectron Model Numbers

4853, 4853S, 4597, 4597S,  
 4859, 4859S, 4877, 4877S, OCO500, OC-260

## Frequency range

10 MHz – 100 MHz

## Standard frequencies

10; 12.8;13; 16.384;20; 32.768MHz; 100Mhz

## Frequency stabilities<sup>1</sup> [AT Cut Crystal – Standard]

Parameter	Min	Typ	Max.	Units	Operating temp range	Ordering Code
vs. operating temperature range (Referenced to +25°C)	-50		+50	ppb	0 ... +70°C	C508
	-100		+100	ppb	-20 ... +70°C	D107
	-150		+150	ppb	-40 ... +70°C	E157
	-200		+200	ppb	-40 ... +85°C	F207
Parameter	Min	Typ	Max.	Units	Condition	
Initial tolerance	-300		+300	ppb	at time of shipment, nominal EFC	
vs. supply voltage change	-10		+10	ppb	V <sub>S</sub> ± 5%	
vs. load change	-10		+10	ppb	Load ± 5%	
vs. aging /1 day	-2.0		+2.0	ppb	after 72 hours of operation	
vs. aging /1 Year	-500		+500	ppb	after 72 hours of operation	
vs. aging / year (following Years)	-250		+250	ppb		
Warm-up Time			3	minutes	to ± 100ppb of final frequency (1 hour reading) @ +25°C	

## Frequency stabilities<sup>1</sup> [SC Cut Crystal – Option]

Parameter	Min	Typ	Max.	Units	Operating temp range	Ordering Code
vs. operating temperature range (Referenced to +25°C)	-10		+10	ppb	0 ... +70°C	C108
	-20		+20	ppb	-20 ... +70°C	D208
	-25		+25	ppb	-40 ... +70°C	E258
	-30		+30	ppb	-40 ... +85°C	F308
Parameter	Min	Typ	Max.	Units	Condition	
Initial tolerance	-100		+100	ppb	at time of shipment, nominal EFC	
vs. supply voltage change	-5.0		+5.0	ppb	V <sub>S</sub> ± 5%	
vs. load change	-5.0		+5.0	ppb	Load ± 5%	
vs. aging /1 day	-1.0		+1.0	ppb	after 72 hours of operation	
vs. aging /1 Year	-100		+100	ppb	after 72 hours of operation	
vs. aging / year (following Years)	-50		+50	ppb		
Warm-up Time			3	minutes	to ± 10ppb of final frequency (1 hour reading) @ +25°C	

## Supply voltage (Vs)

Parameter	Min	Typ	Max.	Units	Condition	Ordering Code
Supply voltage [Standard]	4.75	5	5.25	VDC		SV050
Supply voltage [Option]	11.4	12.0	12.6	VDC		SV120
Supply voltage [Option]	3.135	3.3	3.465	VDC		SV033
Power consumption			3.0	Watts	during warm-up	
			1.0	Watts	steady state @ +25°C	

## RF output

Parameter	Min	Typ	Max.	Units	Condition	Ordering Code
Signal [Standard]	HCMOS					RFH
Load		15		pF	with Vs=12.0V or 5.0V and 15pF load with Vs=3.3V and 15pF load with Vs=12.0V or 5.0V and 15pF load with Vs=3.3V and 15pF load @ (Voh-Vol)/2	
Signal Level (Vol)			0.5	VDC		
Signal Level (Voh)	4.5		0.3	VDC		
Duty cycle	3.0			VDC		
Signal [Option]	Sinewave					RFS
Load		50		Ω	50 Ohm load 50 Ohm load	
Output Power	+3.0	+5.5	+8.0	dBm		
Harmonics			-30	dBc		

## Frequency Tuning (EFC)

Parameter	Min	Typ	Max.	Units	Condition	Ordering Code <sup>5</sup>
Tuning Range	Fixed OCXO; No adjust					0
Tuning Range	±0.75	±1.25	±2.0	ppm	with SC Cut Crystal	1
	±6.0	±8.0	±12	ppm	with AT Cut Crystal	1
Linearity			20	%		
Tuning Slope	Positive					
Control Voltage Range	0.0	2.0	4.0	VDC	with Vs=5.0VDC	
	0.0	2.5	5.0	VDC	with Vs=12VDC	
	0.0	1.4	2.8	VDC	with Vs=3.3VDC	

## Reference Voltage Output (Vref)

Parameter	Min	Typ	Max.	Units	Condition
Reference Voltage	3.92	4.0	4.08	VDC	with Vs=5.0VDC
	4.9	5.0	5.1	VDC	with Vs=12VDC
	2.75	2.8	2.85	VDC	with Vs=3.3VDC

## Additional parameters

Parameter	Min	Typ	Max.	Units	Condition
Phase Noise <sup>3</sup>			-80	dBc/Hz	1 Hz with 10 MHz SC Cut
			-120	dBc/Hz	10 Hz
			-140	dBc/Hz	100 Hz
			-145	dBc/Hz	1 kHz
			-150	dBc/Hz	10 kHz
Phase Noise <sup>3</sup>			-75	dBc/Hz	1 Hz with 10 MHz AT Cut
			-100	dBc/Hz	10 Hz
			-130	dBc/Hz	100 Hz
			-140	dBc/Hz	1 kHz
			-150	dBc/Hz	10 kHz
Weight			14	g	
Processing & Packing	Handling & processing note				

## Absolute Maximum Ratings

Parameter	Min	Typ	Max.	Units	Condition
Supply voltage (Vs)			7.0	V	with Vs=5.0VDC
			15.0	V	with Vs=12VDC
			7.0	V	with Vs=3.3VDC
Output Load			50	pF	with HCMOS signal
			25	Ohms	with Sinewave signal
Operable temperature range	-55		+85	°C	
Storage temperature range	-55		+125	°C	

## Enclosures

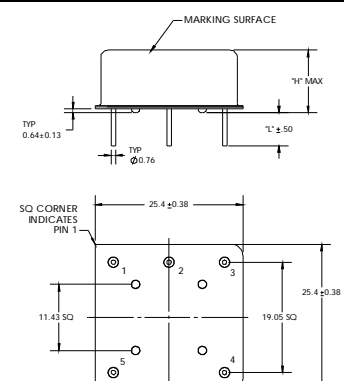
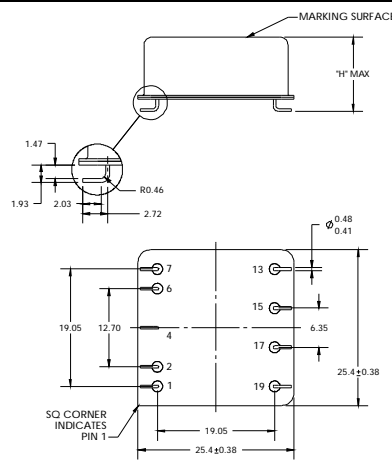
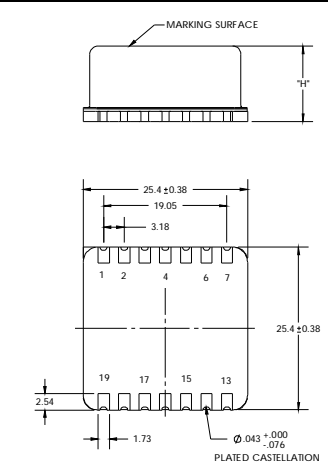
Type A			Type B			Type C		
Package Codes:								
Code	Height "H"	Pin Length "L"	Code	Height "H"	Pin Length "L"	Code	Height "H"	Pin Length "L"
A1	11.25	6.35	B1	12.70	NA	C1	15.24	NA
A2	13.40	6.35	B2	15.24	NA	C2	13.00	NA
A3 <sup>5</sup>	10.00	6.35	B3	11.30	NA	C3	11.70	NA
 <p>Dimensions: mm</p>			 <p>Dimensions: mm</p>			 <p>Dimensions: mm</p>		
Pin Connections			Pin Connections			Pin Connections		
1 RF Output 2 Ground (Case) 3 Electronic Frequency Control Input (EFC) 4 Reference Voltage Output 5 Supply Voltage Input (Vs)			1 RF Output 2 N/C* 4 Ground (Case) 6 N/C* 7 Electronic Frequency Control Input (EFC) 13 Reference Voltage Output (Vref) 15 N/C* 17 N/C* 19 Supply Voltage Input (Vs)			1 RF Output 2 N/C* 4 Ground (Case) 6 N/C* 7 Electronic Frequency Control Input (EFC) 13 Reference Voltage Output (Vref) 15 N/C* 17 N/C* 19 Supply Voltage Input (Vs)		

## Standard Shipping Method (For SMD Type B and C Packages)

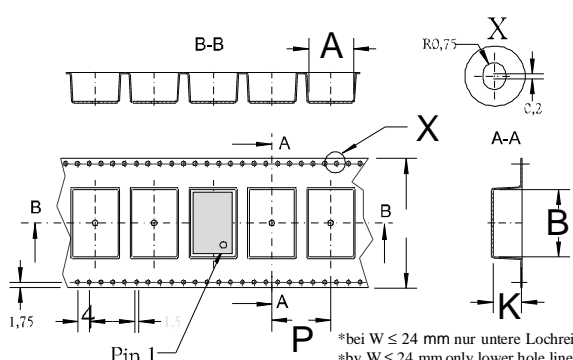
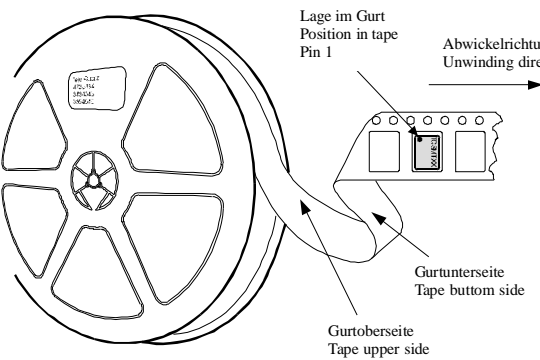



Production tolerance complying DIN IEC 286-3

Enclosure Type	Tape width W [mm]	Quantity per meter	Quantity per reel	Dimension P
Type B	44	33.3	250	34
Type C	44	33.3	250	34

## Recommended Reflow Profile

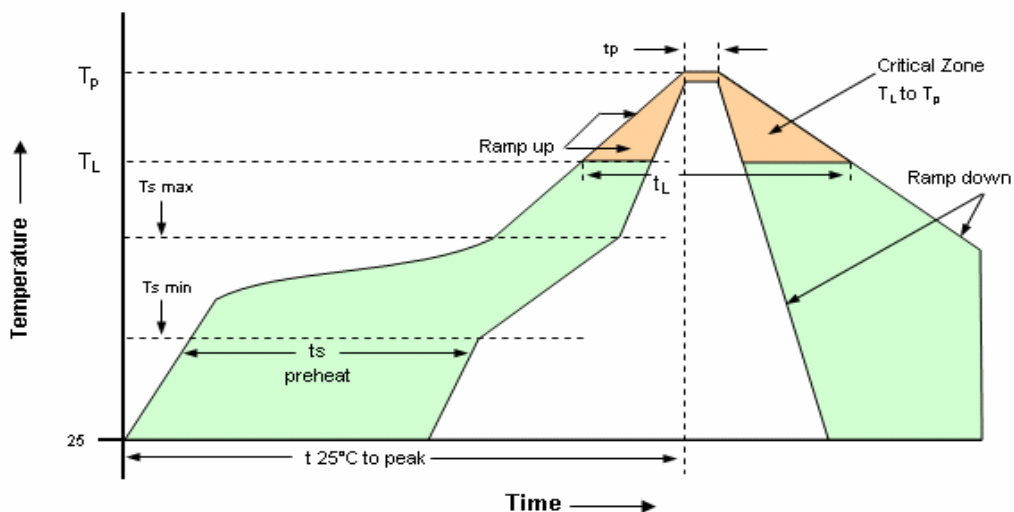
### Solderprofile:



Profile Feature	Pb-Free Assembly /Sn-Pb Assembly	Profile Feature	Pb-Free Assembly /Sn-Pb Assembly
Average ramp-up rate ( $T_L$ to $T_p$ )	3°C/second max.	Time 25°C to Peak Temperature	8 minutes max.
Preheat -Temperature Min ( $T_{s\ min}$ ) -Temperature Min ( $T_{s\ max}$ ) -Time (min to max) ( $t_s$ )	150°C 200°C 60-180 seconds	Time maintained above - Temperature ( $T_L$ ) - Time ( $t_L$ )	217°C 60-150 seconds
$T_{s\ max}$ to $T_L$ - Ramp-up Rate	3°C/second max.		
Time maintained above - Temperature ( $T_L$ ) - Time ( $t_L$ )	217°C 60-150 seconds	Time within 5°C of actual Peak Temperature ( $t_p$ )	20-40 seconds
Peak Temperature ( $T_p$ )	max 260°C	Ramp-down Rate	6°C/second max.

Note: All temperatures refer to topside of the package, measured on the package body surface.

### How to order this product:

Step 1	Use this worksheet to forward the following information to your factory representative:					
Model	Stability Code	Supply Voltage Code	RF Output Code	Package Code	Frequency Control/ Enable	Frequency
C4550	D107	SV050	RFH	A1	1	10MHz

#### Vs.operat. Temp. Range

C508:	±50ppb	0 ...+70°C
D107:	±100ppb	-20 ...+70°C
E157:	±150ppb	-40 ...+70°C
F207:	±200ppb	-40 ...+85°C
C108:	±10ppb	0 ...+70°C
D208:	±20ppb	-20 ...+70°C
E258:	±25ppb	-40 ...+70°C
F308:	±30ppb	-40 ...+85°C

#### Signal:

RFH: HCMOS  
 RFS: Sinewave

#### Tuning Range:

0: Fixed OCXO; No adjust  
 1: ±1.0 ppm..±2.5 ppm(SC)  
 1: ±3.0 ppm..±8.0 ppm(AT)

#### Enclosure:

A1: H: 11.25 L: 6.35  
 A2: H: 13.40 L: 6.35  
 A3: H: 10.00 L: 6.35  
 B1: H: 12.70 L: NA  
 B2: H: 15.24 L: NA  
 B3: H: 11.30 L: NA  
 C1: H: 15.24 L: NA  
 C2: H: 13.00 L: NA  
 C3: H: 11.70 L: NA

#### Supply:

SV050: 5V  
 SV120: 12V  
 SV033: 3.3V

Step 2	The factory representative will then respond with a Vectron Model Number in the following configuration:		
Model	Package Code	Dash	Dash Number
C4550	[Customer Specified Package Code]	-	[Factory Generated 4 digit number]

Typical P/N = C4550A1-0001

#### Notes:

- Contact factory for improved stabilities or additional product options. Not all options and codes are available at all frequencies.
- Unless otherwise stated all values are valid after warm-up time and refer to typical conditions for supply voltage, frequency control voltage, load, temperature (25°C)
- Phase noise degrades with increasing output frequency.
- Subject to technical modification.
- Contact factory for availability.