

FEATURES

- 10 years minimum data retention in the absence of external power
- Data is automatically protected during power loss
- Unlimited write cycles
- Low-power CMOS operation
- Read and write access times as fast as 70 ns
- Lithium energy source is electrically disconnected to retain freshness until power is applied for the first time
- Full $\pm 10\%$ V_{CC} operating range (DS1265Y)
- Optional $\pm 5\%$ V_{CC} operating range (DS1265AB)
- Optional industrial temperature range of -40°C to $+85^{\circ}\text{C}$, designated IND

PIN ASSIGNMENT

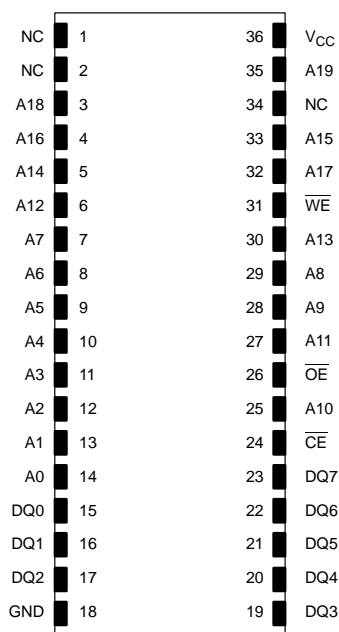

36-PIN ENCAPSULATED PACKAGE
740 MIL EXTENDED

PIN DESCRIPTION

A0 – A19	– Address Inputs
DQ0 – DQ7	– Data In/Data Out
CE	– Chip Enable
WE	– Write Enable
OE	– Output Enable
V_{CC}	– Power (+5V)
GND	– Ground
NC	– No Connect

DESCRIPTION

The DS1265 8M Nonvolatile SRAMs are 8,388,608-bit, fully static nonvolatile SRAMs organized as 1,048,576 words by 8 bits. Each NV SRAM has a self-contained lithium energy source and control circuitry which constantly monitors V_{CC} for an out-of-tolerance condition. When such a condition occurs, the lithium energy

source is automatically switched on and write protection is unconditionally enabled to prevent data corruption. There is no limit on the number of write cycles which can be executed and no additional support circuitry is required for microprocessor interfacing.

READ MODE

The DS1265 devices execute a read cycle whenever \overline{WE} (Write Enable) is inactive (high) and \overline{CE} (Chip Enable) and \overline{OE} (Output Enable) are active (low). The unique address specified by the 20 address inputs ($A_0 - A_{19}$) defines which of the 1,048,576 bytes of data is accessed. Valid data will be available to the eight data output drivers within t_{ACC} (Access Time) after the last address input signal is stable, providing that \overline{CE} and \overline{OE} (Output Enable) access times are also satisfied. If \overline{OE} and \overline{CE} access times are not satisfied, then data access must be measured from the later occurring signal (\overline{CE} or \overline{OE}) and the limiting parameter is either t_{CO} for \overline{CE} or t_{OE} for \overline{OE} rather than t_{ACC} .

WRITE MODE

The DS1265 devices execute a write cycle whenever \overline{WE} and \overline{CE} signals are active (low) after address inputs are stable. The later occurring falling edge of \overline{CE} or \overline{WE} will determine the start of the write cycle. The write cycle is terminated by the earlier rising edge of \overline{CE} or \overline{WE} . All address inputs must be kept valid throughout the write cycle. \overline{WE} must return to the high state for a minimum recovery time (t_{WR}) before another cycle can be initiated. The \overline{OE} control signal should be kept inactive (high) during write cycles to avoid bus contention. However, if the output drivers are enabled (\overline{CE} and \overline{OE} active) then \overline{WE} will disable the outputs in t_{ODW} from its falling edge.

DATA RETENTION MODE

The DS1265AB provides full functional capability for V_{CC} greater than 4.75 volts and write protects by 4.5 volts. The DS1265Y provides full functional capability for V_{CC} greater than 4.5 volts and write protects by 4.25 volts. Data is maintained in the absence of V_{CC} without any additional support circuitry. The nonvolatile static RAMs constantly monitor V_{CC} . Should the supply voltage decay, the NV SRAMs automatically write protect themselves, all inputs become don't care, and all outputs become high impedance. As V_{CC} falls below approximately 3.0 volts, a power switching circuit connects the lithium energy source to RAM to retain data. During power-up, when V_{CC} rises above approximately 3.0 volts, the power switching circuit connects external V_{CC} to RAM and disconnects the lithium energy source. Normal RAM operation can resume after V_{CC} exceeds 4.75 volts for the DS1265AB and 4.5 volts for the DS1265Y.

FRESHNESS SEAL

Each DS1265 device is shipped from Dallas Semiconductor with its lithium energy source disconnected, guaranteeing full energy capacity. When V_{CC} is first applied at a level greater than V_{TP} , the lithium energy source is enabled for battery backup operation.

ABSOLUTE MAXIMUM RATINGS*

Voltage on Any Pin Relative to Ground	-0.3V to +7.0V
Operating Temperature	0°C to 70°C; -40°C to +85°C for IND parts
Storage Temperature	-40°C to +70°C; -40°C to +85°C for IND parts
Soldering Temperature	260°C for 10 seconds

* This is a stress rating only and functional operation of the device at these or any other conditions above those indicated in the operation sections of this specification is not implied. Exposure to absolute maximum rating conditions for extended periods of time may affect reliability.

RECOMMENDED DC OPERATING CONDITIONS(t_A: See Note 10)

PARAMETER	SYMBOL	MIN	TYP	MAX	UNITS	NOTES
DS1265AB Power Supply Voltage	V _{CC}	4.75	5.0	5.25	V	
DS1265Y Power Supply Voltage	V _{CC}	4.5	5.0	5.5	V	
Logic 1 Input Voltage	V _{IH}	2.2		V _{CC}	V	
Logic 0 Input Voltage	V _{IL}	0		+0.8	V	

DC ELECTRICAL CHARACTERISTICS(V_{CC}=5V±5% for DS1265AB)
(t_A: See Note 10) (V_{CC}=5V±10% for DS1265Y)

PARAMETER	SYMBOL	MIN	TYP	MAX	UNITS	NOTES
Input Leakage Current	I _{IL}	-2.0		+2.0	μA	
I/O Leakage Current	I _{IO}	-2.0		+2.0	μA	
Output Current @ 2.4V	I _{OH}	-1.0			mA	
Output Current @ 0.4V	I _{OL}	2.0			mA	
Standby Current $\overline{CE}=2.2V$	I _{CCS1}		1.0	1.5	mA	
Standby Current $\overline{CE}=V_{CC}-0.5V$	I _{CCS2}		100	150	μA	
Operating Current	I _{CCO1}			85	mA	
Write Protection Voltage (DS1265AB)	V _{TP}	4.5	4.62	4.75	V	
Write Protection Voltage (DS1265Y)	V _{TP}	4.25	4.37	4.5	V	

CAPACITANCE(t_A = 25°C)

PARAMETER	SYMBOL	MIN	TYP	MAX	UNITS	NOTES
Input Capacitance	C _{IN}		10	20	pF	
Output Capacitance	C _{I/O}		10	20	pF	

AC ELECTRICAL CHARACTERISTICS

($V_{CC}=5V\pm 5\%$ for DS1265AB)
 (t_A : See Note 10) ($V_{CC}=5V\pm 10\%$ for DS1265Y)

PARAMETER	SYMBOL	DS1265AB-70 DS1265Y-70		DS1265AB-100 DS1265Y-100		UNITS	NOTES
		MIN	MAX	MIN	MAX		
Read Cycle Time	t_{RC}	70		100		ns	
Access Time	t_{ACC}		70		100	ns	
\overline{OE} to Output Valid	t_{OE}		35		50	ns	
\overline{CE} to Output Valid	t_{CO}		70		100	ns	
\overline{OE} or \overline{CE} to Output Active	t_{COE}	5		5		ns	5
Output High-Z from Deselection	t_{OD}		25		35	ns	5
Output Hold from Address Change	t_{OH}	5		5		ns	
Write Cycle Time	t_{WC}	70		100		ns	
Write Pulse Width	t_{WP}	55		75		ns	3
Address Setup Time	t_{AW}	0		0		ns	
Write Recovery Time	t_{WR1} t_{WR2}	5 15		5 15		ns	12 13
Output High-Z from \overline{WE}	t_{ODW}		25		35	ns	5
Output Active from \overline{WE}	t_{OEw}	5		5		ns	5
Data Setup Time	t_{DS}	30		40		ns	4
Data Hold Time	t_{DH1} t_{DH2}	0 10		0 10		ns ns	12 13

TIMING DIAGRAM: READ CYCLE

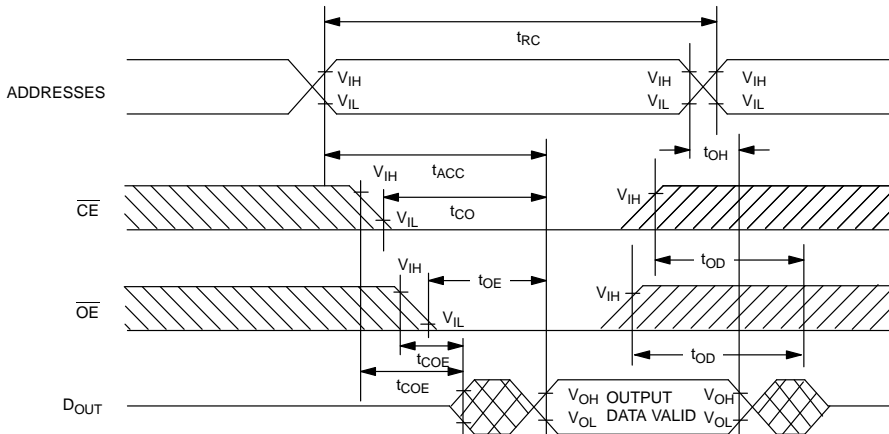

SEE NOTE 1

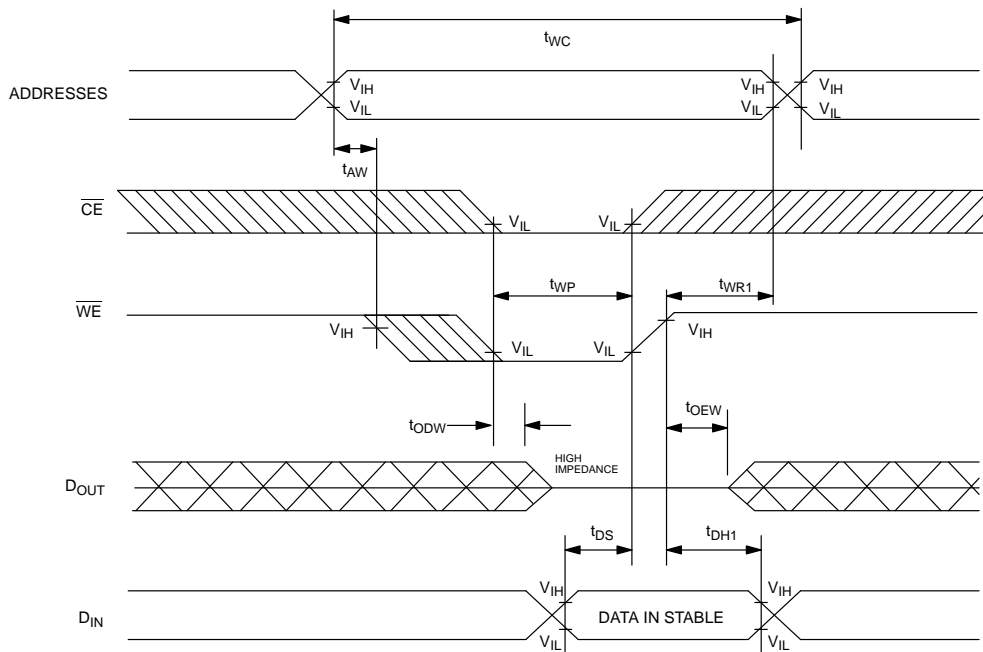
TIMING DIAGRAM: WRITE CYCLE 1

SEE NOTES 2, 3, 4, 6, 7, 8 AND 12

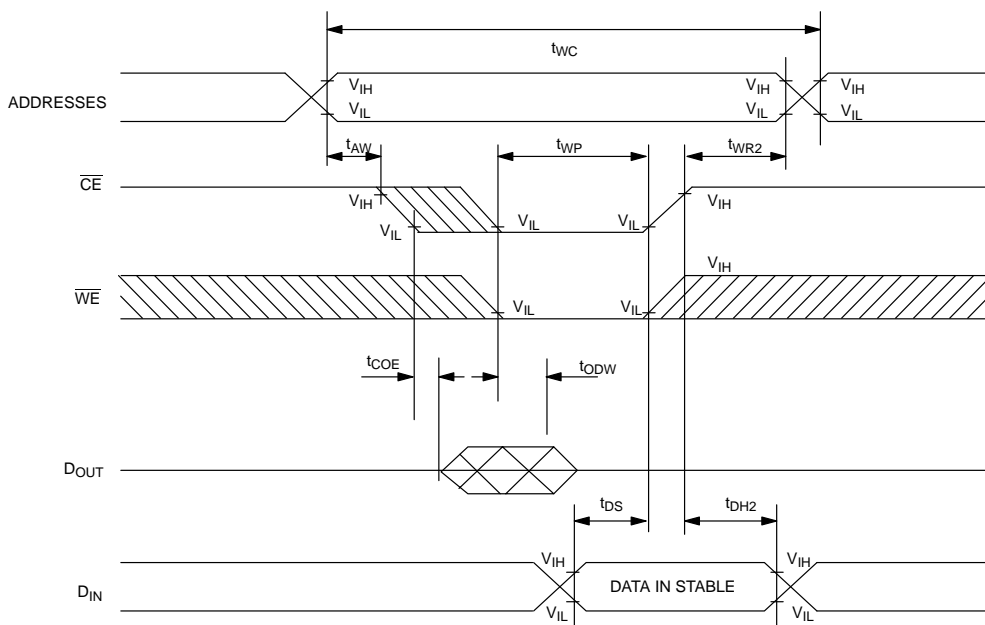
TIMING DIAGRAM: WRITE CYCLE 2

SEE NOTES 2, 3, 4, 6, 7, 8 AND 13

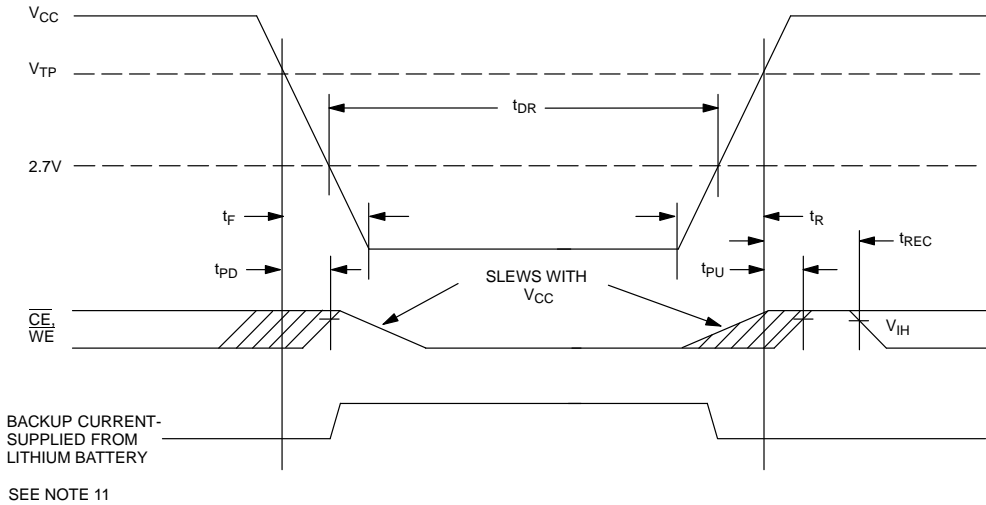
POWER-DOWN/POWER-UP CONDITION**POWER-DOWN/POWER-UP TIMING** $(t_A$: See Note 10)

PARAMETER	SYMBOL	MIN	TYP	MAX	UNITS	NOTES
V_{CC} Fail Detect to \overline{CE} and \overline{WE} Inactive	t_{PD}			1.5	μs	11
V_{CC} Slew from V_{TP} to 0V	t_F	150			μs	
V_{CC} Slew from 0V to V_{TP}	t_R	150			μs	
V_{CC} Valid to \overline{CE} and \overline{WE} Inactive	t_{PU}			2	ms	
V_{CC} Valid to End of Write Protection	t_{REC}			125	ms	

 $(t_A = 25^\circ C)$

PARAMETER	SYMBOL	MIN	TYP	MAX	UNITS	NOTES
Expected Data Retention Time	t_{DR}	10			years	9

WARNING

Under no circumstances are negative undershoots, of any amplitude, allowed when device is in battery backup mode.

NOTES:

- \overline{WE} is high throughout read cycle.
- $\overline{OE} = V_{IH}$ or V_{IL} . If $\overline{OE} = V_{IH}$ during write cycle, the output buffers remain in a high impedance state.
- t_{WP} is specified as the logical AND of \overline{CE} or \overline{WE} . t_{WP} is measured from the latter of \overline{CE} or \overline{WE} going low to the earlier of \overline{CE} or \overline{WE} going high.
- t_{DS} is measured from the earlier of \overline{CE} or \overline{WE} going high.
- These parameters are sampled with a 5 pF load and are not 100% tested.

6. If the \overline{CE} low transition occurs simultaneously with or later than the \overline{WE} low transition, the output buffers remain in a high impedance state during this period.
7. If the \overline{CE} high transition occurs prior to or simultaneously with the \overline{WE} high transition, the output buffers remain in a high impedance state during this period.
8. If \overline{WE} is low or the \overline{WE} low transition occurs prior to or simultaneously with the \overline{CE} low transition, the output buffers remain in a high impedance state during this period.
9. Each DS1265 has a built-in switch that disconnects the lithium source until V_{CC} is first applied by the user. The expected t_{DR} is defined as accumulative time in the absence of V_{CC} starting from the time power is first applied by the user.
10. All AC and DC electrical characteristics are valid over the full operating temperature range. For commercial products, this range is 0°C to 70°C . For industrial products (IND), this range is -40°C to $+85^{\circ}\text{C}$.
11. In a power-down condition the voltage on any pin may not exceed the voltage on V_{CC} .
12. t_{WR1} , t_{DH1} are measured from \overline{WE} going high.
13. t_{WR2} , t_{DH2} are measured from \overline{CE} going high.

DC TEST CONDITIONS

Outputs Open

All voltages are referenced to ground

AC TEST CONDITIONS

Output Load: 100 pF + 1TTL Gate

Input Pulse Levels: 0V to 3.0V

Timing Measurement Reference Levels

Input: 1.5V

Output: 1.5V

Input pulse Rise and Fall Times: 5 ns

ORDERING INFORMATION

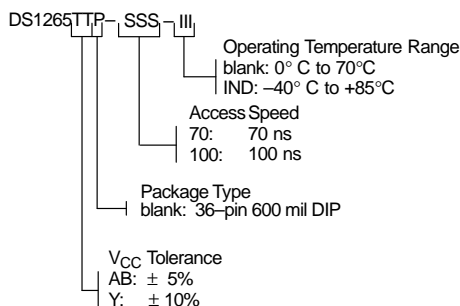

DS1265Y/AB NONVOLATILE SRAM 36-PIN 740 MIL EXTENDED MODULE, LONG

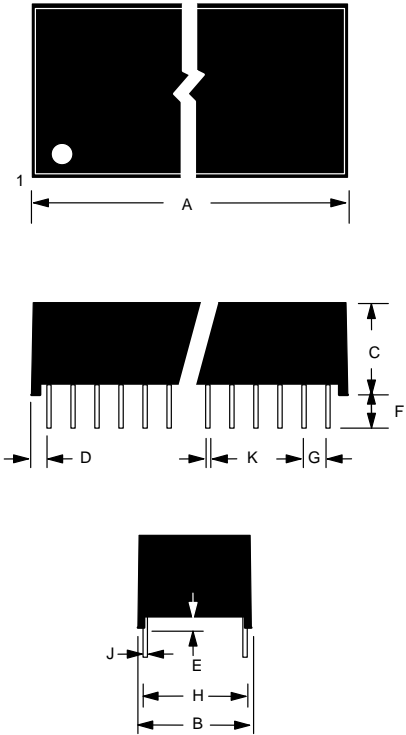

PKG	36-PIN		
	DIM	MIN	MAX
A	IN. MM	2.080 52.83	2.100 53.34
B	IN. MM	0.720 18.29	0.740 18.80
C	IN. MM	0.355 9.02	0.405 10.29
D	IN. MM	0.180 4.57	0.210 5.33
E	IN. MM	0.015 0.38	0.025 0.63
F	IN. MM	0.120 3.05	0.150 4.06
G	IN. MM	0.090 2.29	0.110 2.79
H	IN. MM	0.590 14.99	0.630 16.00
J	IN. MM	0.008 0.20	0.012 0.30
K	IN. MM	0.015 0.38	0.021 0.53