



Introduces

M210x Series PECL/LVDS/CML Clock Oscillator

Featuring **QiK Chip™** Technology

Features:

- Superior Jitter Performance (comparable to SAW based)
- Frequencies from 150 MHz to 1.4 GHz
- Designed for a short 2 week cycle time

Applications:

- Telecommunications such as SONET / SDH / DWDM / FEC / SERDES / OC-3 thru OC-192
- Wireless base stations / WLAN / Gigabit Ethernet
- Avionic flight controls and military communications



MtronPTI

Corporate Headquarters
100 Douglas Avenue
PO Box 630
Yankton, SD 57078-0630
1-800-762-8800
www.mtronpti.com



M210x Series

PECL/LVDS/CML Clock Oscillator – 3.3/2.5/1.8 Volt – 5x7 mm

Product Specifications

Product Features:

- Superior *Jitter Performance* comparable to SAW-based products (0.30pS typical at 622.08 MHz)
- *Frequencies* from 150 MHz to 1.4 GHz
- Crystal resonator based product offering *far better Stability* than SAW (+/-20ppm)
- Designed for *Short Cycle Time* manufacturing (2 weeks or less)
- 0.01 μ F bypass capacitor from Vcc to ground built into 5x7 package

Description:

The M210x Series oscillators are high performance PECL, LVDS, or CML output oscillators featuring exceptional performance while addressing the demands for shortened manufacturing cycle times.

Applications:

- Telecommunications such as SONET / SDH / DWDM / FEC / SERDES / OC-3 thru OC-192
- Wireless base stations / WLAN / Gigabit Ethernet
- Avionic flight controls and military communications
- Test Equipment and Instrumentation

Ordering Information:

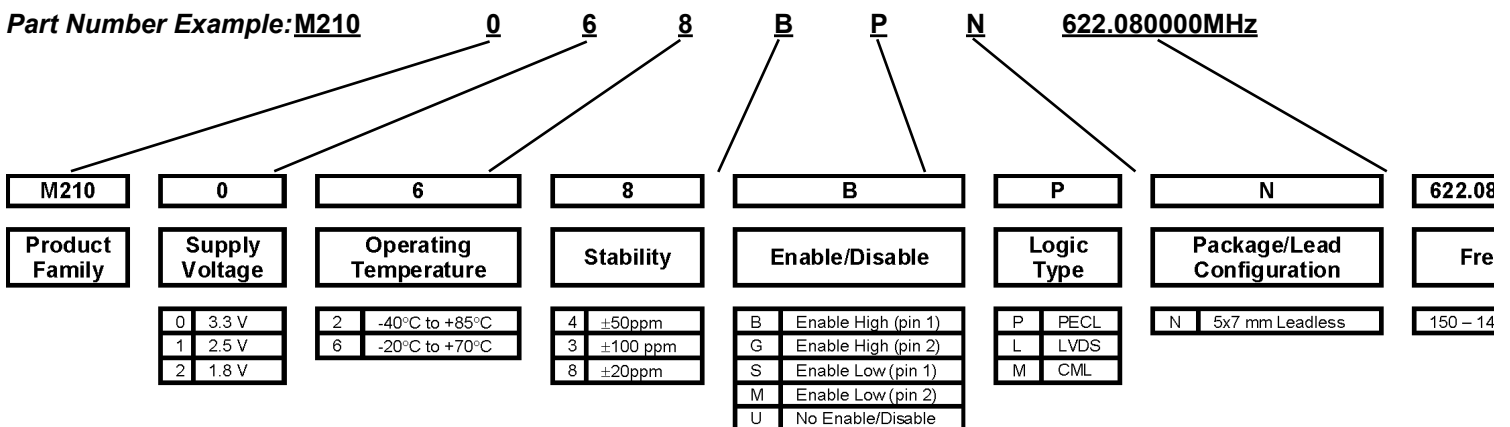

Part Number Example: **M210068BPN – 622.080000 MHz**

Applications Note:

The MtronPTI M210x series of clock oscillators, featuring *QiK Chip™* technology, provides for extremely low jitter of 0.30 ps RMS. For applications requiring low jitter, frequencies from 150 MHz to 1.4 GHz are available. LVPECL, LVDS, or CML compatible outputs, as well as operating voltage of 1.8 V, 2.5 V, and 3.3 V are also options on the M210x.

The M210x is available at a stability of ± 20 ppm, all-inclusive, over the industrial operating temperature range of -40°C to $+85^{\circ}\text{C}$. By providing this specification, the M210x will perform at a much superior level than SAW based oscillator designs (Figure 1). This level of performance is achieved by utilizing a precision AT-cut crystal. An enable/disable function is also an available option on the M210x. The internal 0.01 μF by-pass capacitor also assures optimum noise suppression on the supply voltage pad.

The superior integrated jitter performance of 0.3 pS RMS makes the M210x suitable for 10 Gig-E, broadband networks, network switches, SONET, SDH, SERDES, DWDM, FEC, WLAN, and OC-3 thru OC-192 systems. The M210x is available in a nine-pad, 5x7x1.9 mm, leadless, ceramic, surface mount package (see page 4) that is RoHS and 260 $^{\circ}\text{C}$ reflow compatible. (No PCB traces should be located directly under the 5x7 product). Figures 2 and 3 below show load termination conditions for LVPECL and LVDS. The M210x oscillators offer a pin 1 tristate for backward compatibility to many of the existing products in the industry from Vectron, Epson, and others.

For superior performance in a high frequency clock oscillator, the M210x is a logical choice for designers. The unique design architecture allows the M210x fast turn around on engineering design samples, as well as production quantities in 2 weeks or less.

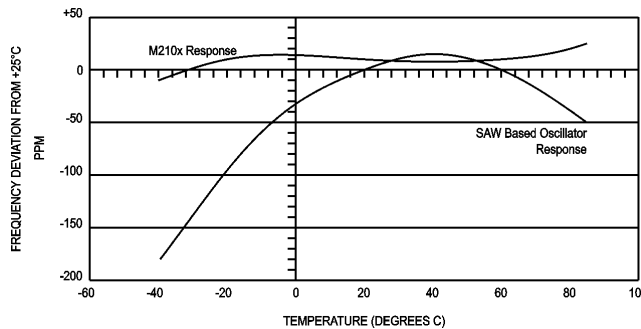

Figure 1. Frequency/Temperature Curves, M210x vs. SAW Based Oscillator Devices

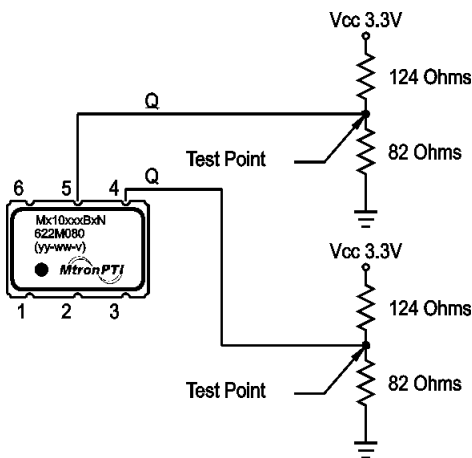

Figure 2. 3.3V LVPECL Load Circuit

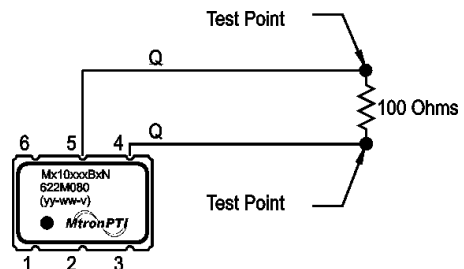

Figure 3. LVDS Load Circuit

MtronPTI reserves the right to make changes to the product(s) and service(s) described herein without notice. No liability is assumed as a result of their use or application.

Please see www.mtronpti.com for our complete offering and detailed datasheets. Contact us for your application specific requirements: MtronPTI 1-800-762-8800.

Performance Characteristics:

PARAMETER	Symbol	Min.	Typ.	Max.	Units	Condition/Notes	
Frequency Range	F	150		1400	MHz	Note 1	
Operating Temperature	T _A	(See ordering information)					
Storage Temperature	T _S	-55		+125	°C		
Frequency Stability	ΔF/F	(See ordering information)					See Note 2
Aging							
1st Year		-3		+3	ppm		
Thereafter (per year)		-1		+1	ppm		
Supply Voltage	V _{cc}	1.71	1.8	1.89	V		
		2.375	2.5	2.625	V		
		3.135	3.3	3.465	V		
Input Current	I _{cc}			125	mA	LVPECL/LVDS/CML	
Load		50 Ohms to (V _{cc} -2) Vdc 100 Ohm differential load				See Note 3 LVPECL Waveform LVDS/CML Waveform	
Symmetry (Duty Cycle)		45		55	%	@ 50% of waveform	
Output Skew			TBD				
Differential Voltage		350	425 TBD	500	mVppd	LVDS CML	
Common Mode Output Voltage	V _{cm}		1.2		V	LVDS	
Logic "1" Level	V _{oh}	V _{cc} -1.02			V	LVPECL	
Logic "0" Level	V _{ol}			V _{cc} -1.63	V	LVPECL	
Rise/Fall Time	Tr/Tf		0.23	0.50	ns	@ 20/80% LVPECL	
Enable Function		80% V _{cc} min. or N/C: output active 20% V _{cc} max.: output disables to high-Z				Output Option B or G	
		20% V _{cc} max: output active 80% V _{cc} min.: output disables to high-Z				Output Option S or M	
Start up Time			10		ms		
Phase Jitter @ 622.08 MHz	φ _J		0.3		ps RMS	Integrated 12 kHz – 20 MHz	
Phase Noise 10 Hz 100 Hz 1 KHz 10 KHz 100 KHz 1 MHz 10 MHz 40 MHz			-50 -80 -106 -117 -120 -130 -147 -150			@ 622.08 MHz dBc/Hz dBc/Hz dBc/Hz dBc/Hz dBc/Hz dBc/Hz dBc/Hz dBc/Hz	
Mechanical Shock	Per MIL-STD-202, Method 213, Condition C (100 g's, 6 mS duration, ½ sinewave)						
Vibration	Per MIL-STD-202, Method 201 & 204 (10 g's from 10-2000 Hz)						
Hermeticity	Per MIL-STD-202, Method 112, (1x10 ⁻⁸ atm. cc/s of Helium)						
Thermal Cycle	Per MIL-STD-883, Method 1010, Condition B (-55°C to +125°C, 15 min. dwell, 10 cycles)						
Solderability	Per EIAJ-STD-002						
Soldering Conditions	+240°C max. for 10 secs.						

Note 1: Contact factory for exact frequency availability over 945 MHz

Note 2: Stability is inclusive of initial tolerance, deviation over temperature, shock, vibration, supply voltage, and aging for one year at 50°C mean ambient temperature.

Note 3: See Load Circuit Diagram in this Datasheet. Consult factory with nonstandard output load requirements.

MtronPTI reserves the right to make changes to the product(s) and service(s) described herein without notice. No liability is assumed as a result of their use or application.

Please see www.mtronpti.com for our complete offering and detailed datasheets. Contact us for your application specific requirements: MtronPTI 1-800-762-8800.

Product Dimensions & Pinout Information:

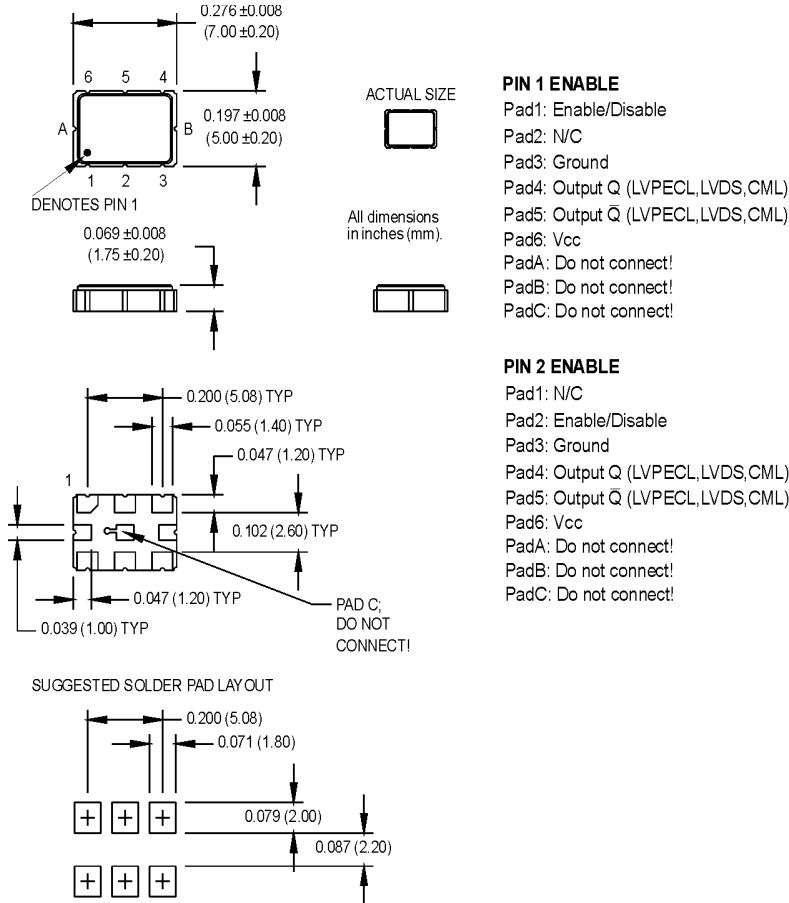

Handling Information:

Although protection circuitry has been designed into the M210x oscillator, proper precautions should be taken to avoid exposure to electrostatic discharge (ESD) during handling and mounting. MtronPTI utilizes a human-body model (HBM) and a charged-device model (CDM) for ESD-susceptibility testing and protection design evaluation. ESD voltage thresholds are dependent on the circuit parameters used to define the mode. Although no industry-wide standard has been adopted for the CDM, a standard HBM (resistance = 1500 Ω, capacitance = 100 pF) is widely used and therefore can be used for comparison purposes. The HBM ESD threshold presented here was obtained using these circuit parameters.

Model	ESD Threshold, Minimum	Unit
Human Body	1500*	V
Charged Device	1500*	V

* MIL-STD-883D, Method 3015, Class 1

MtronPTI reserves the right to make changes to the product(s) and service(s) described herein without notice. No liability is assumed as a result of their use or application.

Please see www.mtronpti.com for our complete offering and detailed datasheets. Contact us for your application specific requirements: MtronPTI 1-800-762-8800.

Solder Profile:

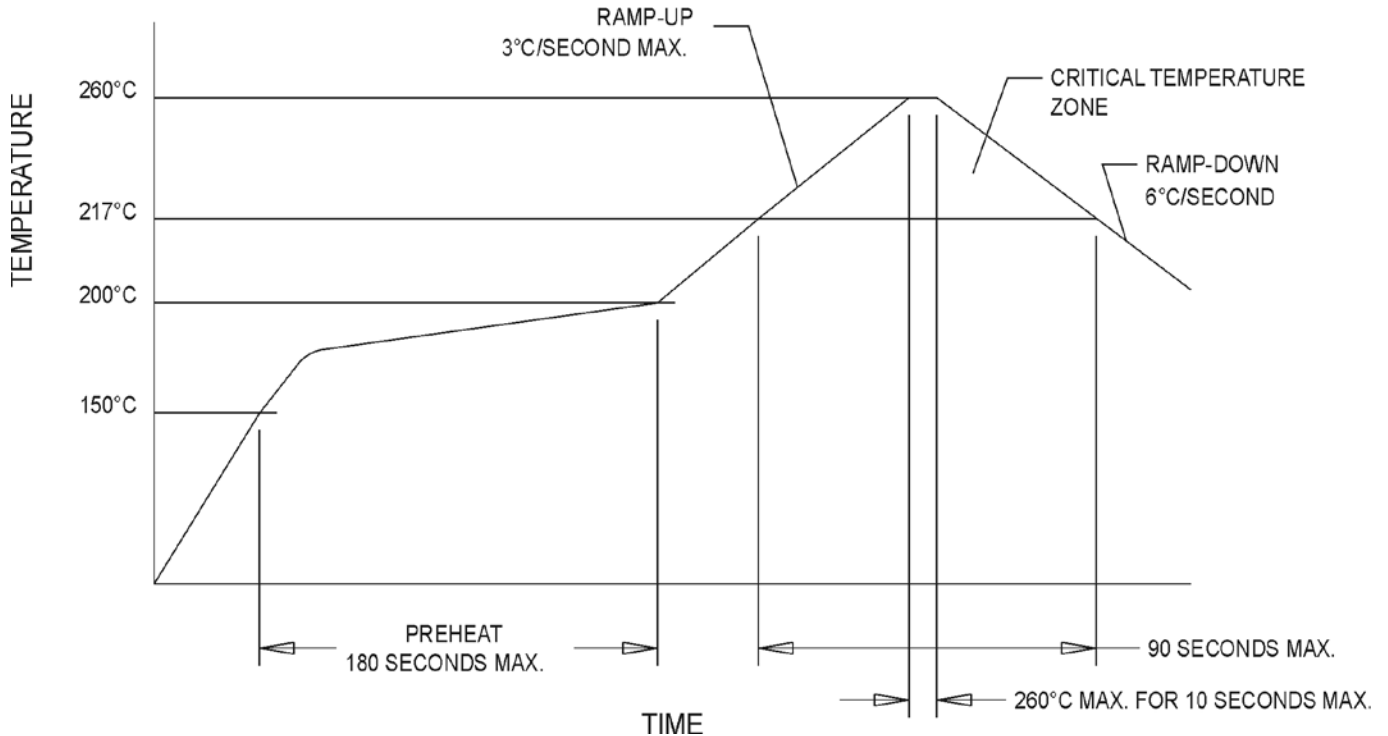

Quality Parameters:

Environmental Specifications/Qualification Testing Performed on the M210 Clock Oscillator		
Test	Test Method	Test Condition
Electrical Characteristics	Internal Specification	Per Specification
Frequency vs. Temperature	Internal Specification	Per Specification
Mechanical Shock	MIL-STD-202, Method 213, C	100 g's
Vibration	MIL-STD-202, Method 201-204	10 g's from 10-2000 Hz
Thermal Cycle	MIL-STD-883, Method 1010, B	-55 Deg. C to +125 Deg. C, 15 minute Dwell, 10 cycles
Aging	Internal Specification	168 Hours at 105 Degrees C
Gross Leak	MIL-STD-202, Method 112	30 Second Immersion
Fine Leak	MIL-STD-202, Method 112	Must meet 1×10^{-8}
Solderability	MIL-STD-883, Method 2003	8 Hour Steam Age – Must Exhibit 95% coverage
Resistance to Solvents	MIL-STD-883, Method 2015	Three 1 minute soaks
Terminal Pull	MIL-STD-883, Method 2004, A	2 Pounds
Lead Bend	MIL-STD-883, Method 2004, B1	1 Bending Cycle
Physical Dimensions	MIL-STD-883, Method 2016	Per Specification
Internal Visual	Internal Specification	Per Internal Specification

MtronPTI reserves the right to make changes to the product(s) and service(s) described herein without notice. No liability is assumed as a result of their use or application.

Please see www.mtronpti.com for our complete offering and detailed datasheets. Contact us for your application specific requirements: MtronPTI 1-800-762-8800.

Tape and Reel Specifications:

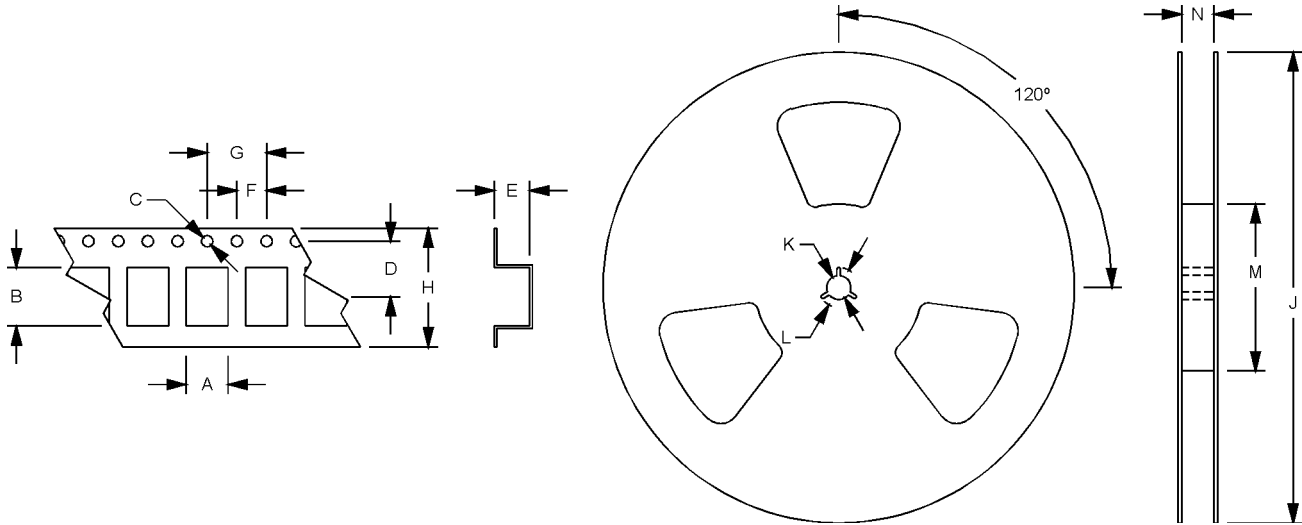

Product	A	B	C	D	E	F	G	H	I	J	K	L
M210x	6.51	9.29	1.5	7.5	2.8	4	8/12	16	180-330	13	21	60-100

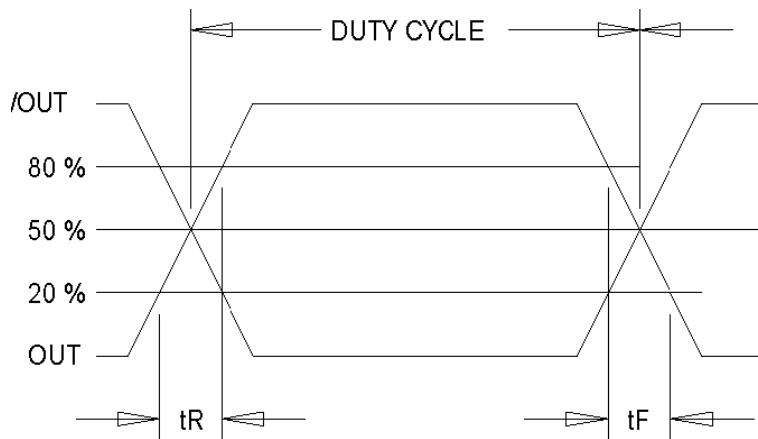

Output Waveform: LVDS/CML/PECL



Yankton

PO Box 630
Yankton, SD 57078-0630 USA
Phone: 605-665-9321
Toll Free: 800-762-8800
Fax: 605-665-1709
Email: SalesYKT@mtronpti.com

Orlando

2525 Shader Rd
Orlando, FL 32804 USA
Phone: 407-298-2000
Fax: 407-293-2979
Email: SalesORL@mtronpti.com

Connecticut

755 Main Street
Suite 2B, Building 2
Monroe, CT 06470 USA
Phone: 800.762.8800
Fax: 203.452.9435
Email: MilSales@mtronpti.com

San Jose

985 University Ave
Suite 38
Los Gatos, CA 95032 USA
Phone: 408-395-0700
Fax: 408-395-8074
Email: SalesCA@mtronpti.com

Europe

The Netherlands
Phone: 31-40-368-6818
Fax: 011-31-40-368-3501
Email: SalesEU@mtronpti.com

Asia Pacific

1104 Shanghai Industrial
Investment Building
48-62 Hennessy Road
Wanchai, Hong Kong, China
Phone: 852-2866-8023
Fax: 852-2529-1822
Email: SalesHK@mtronpti.com