

LHF00L13

Flash Memory

32M (2MB × 16)

(Model No.: LHF100L13)

Spec No.: EL163054

Issue Date: March16, 2004

SPEC No.	EL163054
ISSUE:	Mar. 16, 2004

To: _____

SPECIFICATIONS

Product Type 32 Mbit Flash Memory

LHF00L13

Model No. (LHF00L13)

If you have any objections, please contact us before issuing purchasing order.

- * This specifications contains 34 pages including the cover and appendix.
- * Refer to LHF00LXX series Appendix (FUM03802).

CUSTOMERS ACCEPTANCE

DATE: _____

BY: _____

PRESENTED

BY: Y. Hotta
Y/HOTTA
Dept. General Manager

REVIEWED BY:

PREPARED BY:

H. Takata S. Otani

Product Development Dept. I
System-Flash Division
Integrated Circuits Group
SHARP CORPORATION

- Handle this document carefully for it contains material protected by international copyright law. Any reproduction, full or in part, of this material is prohibited without the express written permission of the company.
- When using the products covered herein, please observe the conditions written herein and the precautions outlined in the following paragraphs. In no event shall the company be liable for any damages resulting from failure to strictly adhere to these conditions and precautions.
 - (1) The products covered herein are designed and manufactured for the following application areas. When using the products covered herein for the equipment listed in Paragraph (2), even for the following application areas, be sure to observe the precautions given in Paragraph (2). Never use the products for the equipment listed in Paragraph (3).
 - Office electronics
 - Instrumentation and measuring equipment
 - Machine tools
 - Audiovisual equipment
 - Home appliance
 - Communication equipment other than for trunk lines
 - (2) Those contemplating using the products covered herein for the following equipment which demands high reliability, should first contact a sales representative of the company and then accept responsibility for incorporating into the design fail-safe operation, redundancy, and other appropriate measures for ensuring reliability and safety of the equipment and the overall system.
 - Control and safety devices for airplanes, trains, automobiles, and other transportation equipment
 - Mainframe computers
 - Traffic control systems
 - Gas leak detectors and automatic cutoff devices
 - Rescue and security equipment
 - Other safety devices and safety equipment, etc.
 - (3) Do not use the products covered herein for the following equipment which demands extremely high performance in terms of functionality, reliability, or accuracy.
 - Aerospace equipment
 - Communications equipment for trunk lines
 - Control equipment for the nuclear power industry
 - Medical equipment related to life support, etc.
 - (4) Please direct all queries and comments regarding the interpretation of the above three Paragraphs to a sales representative of the company.
- Please direct all queries regarding the products covered herein to a sales representative of the company.

CONTENTS

PAGE	PAGE
48-Lead TSOP (Normal Bend) Pinout 3	1 Electrical Specifications 14
Pin Descriptions..... 4	1.1 Absolute Maximum Ratings..... 14
Memory Map..... 5	1.2 Operating Conditions 14
Identifier Codes and OTP Address for Read Operation 6	1.2.1 Capacitance..... 15
OTP Block Address Map for OTP Program..... 7	1.2.2 AC Input/Output Test Conditions..... 15
Bus Operation..... 8	1.2.3 DC Characteristics..... 16
Command Definitions 9	1.2.4 AC Characteristics - Read-Only Operations..... 18
Functions of Block Lock and Block Lock-Down..... 11	1.2.5 AC Characteristics - Write Operations 20
Block Locking State Transitions upon Command Write..... 11	1.2.6 Reset Operations..... 22
Block Locking State Transitions upon WP# Transition..... 12	1.2.7 Block Erase, Full Chip Erase, Program and OTP Program Performance. 23
Status Register Definition..... 13	2 Related Document Information 24
	3 Package and packing specification..... 25

LHF00L13

32Mbit (2Mbit×16)

Flash MEMORY

- 32-M density with 16-bit I/O Interface
- Read Operation
 - 90ns
- Low Power Operation
 - 2.7V Read and Write Operations
 - V_{CCQ} for Input/Output Power Supply Isolation
 - Automatic Power Savings Mode reduces I_{CCR} in Static Mode
- Enhanced Code + Data Storage
 - 5 μ s Typical Erase/Program Suspends
- OTP (One Time Program) Block
 - 4-Word Factory-Programmed Area
 - 4-Word User-Programmable Area
- Operating Temperature -40°C to +85°C
- CMOS Process (P-type silicon substrate)
- Flexible Blocking Architecture
 - Eight 4-Kword Parameter Blocks
 - One 32-Kword Block
 - Thirty-one 64-Kword Blocks
 - Bottom Parameter Location
- Enhanced Data Protection Features
 - Individual Block Lock and Block Lock-Down with Zero-Latency
 - All blocks are locked at power-up or device reset.
 - Absolute Protection with $V_{PP} \leq V_{PPLK}$
 - Block Erase, Full Chip Erase, Word Program Lockout during Power Transitions
- Automated Erase/Program Algorithms
 - 3.0V Low-Power 10 μ s/Word (Typ.) Programming
 - 12.0V No Glue Logic 9 μ s/Word (Typ.) Production Programming and 0.8s Erase (Typ.)
- Cross-Compatible Command Support
 - Basic Command Set
 - Common Flash Interface (CFI)
- Extended Cycling Capability
 - Minimum 100,000 Block Erase Cycles
- 48-Lead TSOP (Normal Bend)
- ETOX™* Flash Technology
- Not designed or rated as radiation hardened

The product is a low power, high density, low cost, nonvolatile read/write storage solution for a wide range of applications. The product can operate at $V_{CC}=2.7V-3.6V$ and $V_{PP}=1.65V-3.6V$ or $11.7V-12.3V$. Its low voltage operation capability greatly extends battery life for portable applications.

The memory array block architecture utilizes Enhanced Data Protection features, which provides maximum flexibility for safe nonvolatile code and data storage.

Special OTP (One Time Program) block provides an area to store permanent code such as an unique number.

* ETOX is a trademark of Intel Corporation.

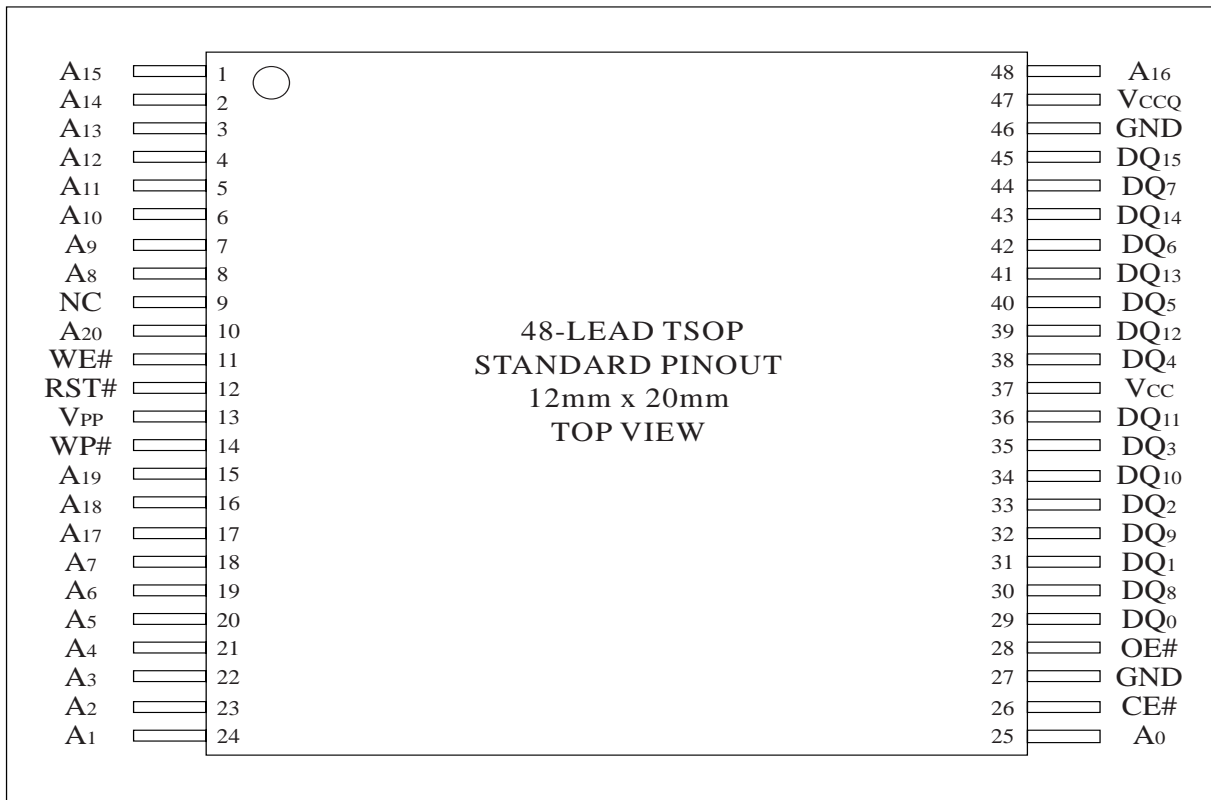

Figure 1. 48-Lead TSOP (Normal Bend) Pinout

Table 1. Pin Descriptions

Symbol	Type	Name and Function
A ₂₀ -A ₀	INPUT	ADDRESS INPUTS: Inputs for addresses.
DQ ₁₅ -DQ ₀	INPUT/ OUTPUT	DATA INPUTS/OUTPUTS: Inputs data and commands during CUI (Command User Interface) write cycles, outputs data during memory array, status register, query code, identifier code reads. Data pins float to high-impedance (High Z) when the chip or outputs are deselected. Data is internally latched during an erase or program cycle.
CE#	INPUT	CHIP ENABLE: Activates the device's control logic, input buffers, decoders and sense amplifiers. CE#-high (V _{IH}) deselected the device and reduces power consumption to standby levels.
RST#	INPUT	RESET: When low (V _{IL}), RST# resets internal automation and inhibits write operations which provides data protection. RST#-high (V _{IH}) enables normal operation. After power-up or reset mode, the device is automatically set to read array mode. RST# must be low during power-up/down.
OE#	INPUT	OUTPUT ENABLE: Gates the device's outputs during a read cycle.
WE#	INPUT	WRITE ENABLE: Controls writes to the CUI and array blocks. Addresses and data are latched on the rising edge of CE# or WE# (whichever goes high first).
WP#	INPUT	WRITE PROTECT: When WP# is V _{IL} , locked-down blocks cannot be unlocked. Erase or program operation can be executed to the blocks which are not locked and not locked-down. When WP# is V _{IH} , lock-down is disabled.
V _{PP}	INPUT/SUPPLY	MONITORING POWER SUPPLY VOLTAGE: V _{PP} is not used for power supply pin. With V _{PP} ≤ V _{PPLK} , block erase, full chip erase, program or OTP program cannot be executed and should not be attempted. Applying 12.0V ± 0.3V to V _{PP} provides fast erasing or fast programming mode. In this mode, V _{PP} is power supply pin. Applying 12.0V ± 0.3V to V _{PP} during erase/program can only be done for a maximum of 1,000 cycles on each block. V _{PP} may be connected to 12.0V ± 0.3V for a total of 80 hours maximum. Use of this pin at 12.0V + 0.3V beyond these limits may reduce block cycling capability or cause permanent damage.
V _{CC}	SUPPLY	DEVICE POWER SUPPLY (2.7V-3.6V): With V _{CC} ≤ V _{LKO} , all write attempts to the flash memory are inhibited. Device operations at invalid V _{CC} voltage (see DC Characteristics) produce spurious results and should not be attempted.
V _{CCQ}	SUPPLY	INPUT/OUTPUT POWER SUPPLY (2.7V-3.6V): Power supply for all input/output pins.
GND	SUPPLY	GROUND: Do not float any ground pins.
NC		NO CONNECT: Lead is not internally connected; it may be driven or floated.

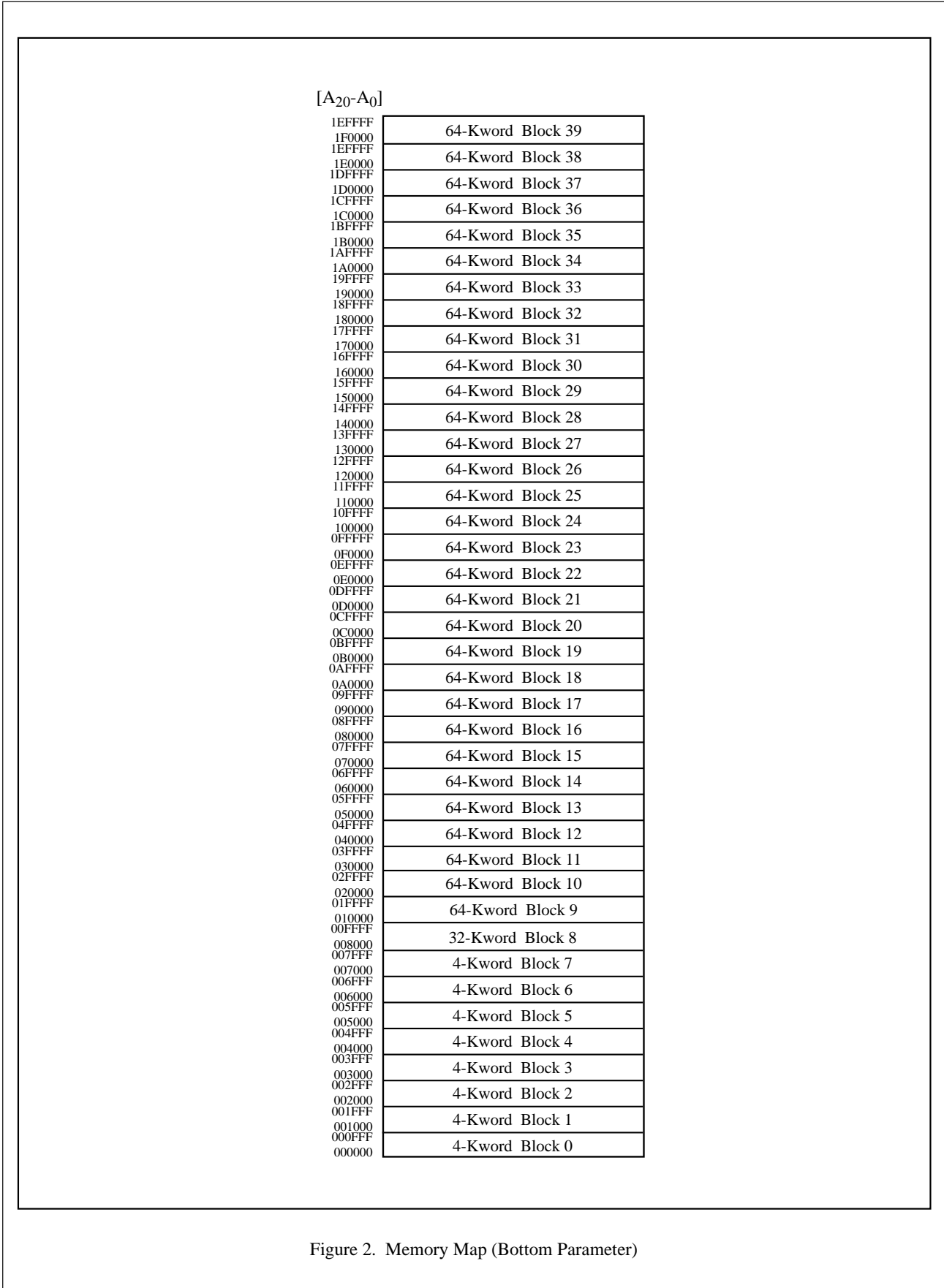

Figure 2. Memory Map (Bottom Parameter)

Table 2. Identifier Codes and OTP Address for Read Operation

	Code	Address [A ₂₀ -A ₀]	Data [DQ ₁₅ -DQ ₀]	Notes
Manufacturer Code	Manufacturer Code	000000H	00B0H	
Device Code	Device Code	000001H	00A1H	
Block Lock Configuration Code	Block is Unlocked	Block Address + 2	DQ ₀ = 0	1
	Block is Locked		DQ ₀ = 1	1
	Block is not Locked-Down		DQ ₁ = 0	1
	Block is Locked-Down		DQ ₁ = 1	1
OTP	OTP Lock	000080H	OTP-LK	2
	OTP	000081-000088H	OTP	3

NOTES:

1. Block Address = The beginning location of a block address. DQ₁₅-DQ₂ are reserved for future implementation.
2. OTP-LK=OTP Block Lock configuration.
3. OTP=OTP Block data.

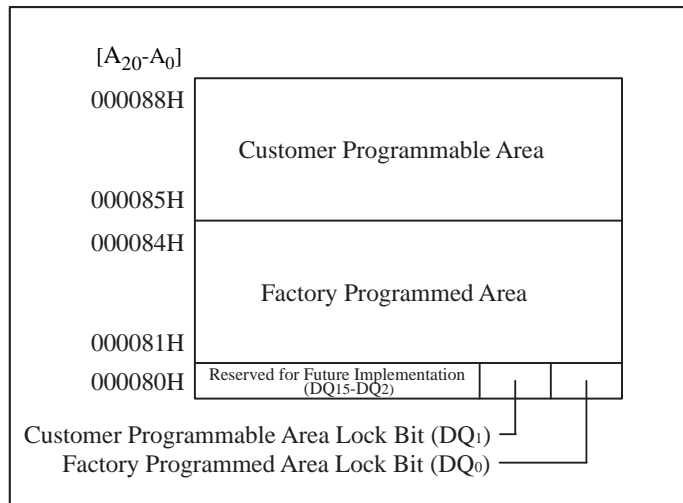

Figure 3. OTP Block Address Map for OTP Program
(The area outside 80H~88H cannot be used.)

Table 3. Bus Operation^(1, 2)

Mode	Notes	RST#	CE#	OE#	WE#	Address	V _{PP}	DQ ₁₅₋₀
Read Array	6	V _{IH}	V _{IL}	V _{IL}	V _{IH}	X	X	D _{OUT}
Output Disable		V _{IH}	V _{IL}	V _{IH}	V _{IH}	X	X	High Z
Standby		V _{IH}	V _{IH}	X	X	X	X	High Z
Reset	3	V _{IL}	X	X	X	X	X	High Z
Read Identifier Codes/OTP	6	V _{IH}	V _{IL}	V _{IL}	V _{IH}	See Table 2	X	See Table 2
Read Query	6,7	V _{IH}	V _{IL}	V _{IL}	V _{IH}	See Appendix	X	See Appendix
Read Status Register	6	V _{IH}	V _{IL}	V _{IL}	V _{IH}	X	X	D _{OUT}
Write	4,5,6	V _{IH}	V _{IL}	V _{IH}	V _{IL}	X	V _{PPH1/2}	D _{IN}

NOTES:

1. Refer to DC Characteristics. When $V_{PP} \leq V_{PPLK}$, memory contents can be read, but cannot be altered.
2. X can be V_{IL} or V_{IH} for control pins and addresses, and V_{PPLK} or V_{PPH1/2} for V_{PP}. Refer to DC Characteristics for V_{PPLK} and V_{PPH1/2} voltages.
3. RST# at GND±0.2V ensures the lowest power consumption.
4. Command writes involving block erase, full chip erase, program or OTP program are reliably executed when $V_{PP} = V_{PPH1/2}$ and $V_{CC} = 2.7V - 3.6V$.
5. Refer to Table 4 for valid D_{IN} during a write operation.
6. Never hold OE# low and WE# low at the same timing.
7. Refer to Appendix of LHF00LXX series for more information about query code.

Table 4. Command Definitions⁽¹⁰⁾

Command	Bus Cycles Req'd	Notes	First Bus Cycle			Second Bus Cycle		
			Oper ⁽¹⁾	Addr ⁽²⁾	Data	Oper ⁽¹⁾	Addr ⁽²⁾	Data ⁽³⁾
Read Array	1		Write	X	FFH			
Read Identifier Codes/OTP	≥ 2	4	Write	X	90H	Read	IA or OA	ID or OD
Read Query	≥ 2	4	Write	X	98H	Read	QA	QD
Read Status Register	2		Write	X	70H	Read	X	SRD
Clear Status Register	1		Write	X	50H			
Block Erase	2	5	Write	BA	20H	Write	BA	D0H
Full Chip Erase	2	5, 8	Write	X	30H	Write	X	D0H
Program	2	5,6	Write	WA	40H or 10H	Write	WA	WD
Block Erase and Program Suspend	1	7, 8	Write	X	B0H			
Block Erase and Program Resume	1	7, 8	Write	X	D0H			
Set Block Lock Bit	2		Write	BA	60H	Write	BA	01H
Clear Block Lock Bit	2	9	Write	BA	60H	Write	BA	D0H
Set Block Lock-down Bit	2		Write	BA	60H	Write	BA	2FH
OTP Program	2	8	Write	OA	C0H	Write	OA	OD

NOTES:

- Bus operations are defined in Table 3.
- All addresses which are written at the first bus cycle should be the same as the addresses which are written at the second bus cycle.
X=Any valid address within the device.
IA=Identifier codes address (See Table 2).
QA=Query codes address. Refer to Appendix of LHF00LXX series for details.
BA=Address within the block being erased, set/cleared block lock bit or set block lock-down bit.
WA=Address of memory location for the Program command.
OA=Address of OTP block to be read or programmed (See Figure 3).
- ID=Data read from identifier codes. (See Table 2).
QD=Data read from query database. Refer to Appendix of LHF00LXX series for details.
SRD=Data read from status register. See Table 8 for a description of the status register bits.
WD=Data to be programmed at location WA. Data is latched on the rising edge of WE# or CE# (whichever goes high first) during command write cycles.
OD=Data within OTP block. Data is latched on the rising edge of WE# or CE# (whichever goes high first) during command write cycles.
- Following the Read Identifier Codes/OTP command, read operations access manufacturer code, device code, block lock configuration code and the data within OTP block (See Table 2).
The Read Query command is available for reading CFI (Common Flash Interface) information.
- Block erase, full chip erase or program cannot be executed when the selected block is locked. Unlocked block can be erased or programmed when RST# is V_{IH}.
- Either 40H or 10H are recognized by the CUI (Command User Interface) as the program setup.
- If the program operation and the erase operation are both suspended, the suspended program operation will be resumed first.
- Full chip erase and OTP program operations can not be suspended. The OTP Program command can not be accepted while the block erase operation is being suspended.

9. Following the Clear Block Lock Bit command, block which is not locked-down is unlocked when WP# is V_{IL} . When WP# is V_{IH} , lock-down bit is disabled and the selected block is unlocked regardless of lock-down configuration.
10. Commands other than those shown above are reserved by SHARP for future device implementations and should not be used.

Table 5. Functions of Block Lock⁽⁵⁾ and Block Lock-Down

Current State					Erase/Program Allowed ⁽²⁾
State	WP#	DQ ₁ ⁽¹⁾	DQ ₀ ⁽¹⁾	State Name	
[000]	0	0	0	Unlocked	Yes
[001] ⁽³⁾	0	0	1	Locked	No
[011]	0	1	1	Locked-down	No
[100]	1	0	0	Unlocked	Yes
[101] ⁽³⁾	1	0	1	Locked	No
[110] ⁽⁴⁾	1	1	0	Lock-down Disable	Yes
[111]	1	1	1	Lock-down Disable	No

NOTES:

- DQ₀=1: a block is locked; DQ₀=0: a block is unlocked.
DQ₁=1: a block is locked-down; DQ₁=0: a block is not locked-down.
- Erase and program are general terms, respectively, to express: block erase, full chip erase and program operations.
- At power-up or device reset, all blocks default to locked state and are not locked-down, that is, [001] (WP#=0) or [101] (WP#=1), regardless of the states before power-off or reset operation.
- When WP# is driven to V_{IL} in [110] state, the state changes to [011] and the blocks are automatically locked.
- OTP (One Time Program) block has the lock function which is different from those described above.

Table 6. Block Locking State Transitions upon Command Write⁽⁴⁾

Current State				Result after Lock Command Written (Next State)		
State	WP#	DQ ₁	DQ ₀	Set Lock ⁽¹⁾	Clear Lock ⁽¹⁾	Set Lock-down ⁽¹⁾
[000]	0	0	0	[001]	No Change	[011] ⁽²⁾
[001]	0	0	1	No Change ⁽³⁾	[000]	[011]
[011]	0	1	1	No Change	No Change	No Change
[100]	1	0	0	[101]	No Change	[111] ⁽²⁾
[101]	1	0	1	No Change	[100]	[111]
[110]	1	1	0	[111]	No Change	[111] ⁽²⁾
[111]	1	1	1	No Change	[110]	No Change

NOTES:

- "Set Lock" means Set Block Lock Bit command, "Clear Lock" means Clear Block Lock Bit command and "Set Lock-down" means Set Block Lock-Down Bit command.
- When the Set Block Lock-Down Bit command is written to the unlocked block (DQ₀=0), the corresponding block is locked-down and automatically locked at the same time.
- "No Change" means that the state remains unchanged after the command written.
- In this state transitions table, assumes that WP# is not changed and fixed V_{IL} or V_{IH}.

Table 7. Block Locking State Transitions upon WP# Transition⁽⁴⁾

Previous State	Current State				Result after WP# Transition (Next State)	
	State	WP#	DQ ₁	DQ ₀	WP#=0→1 ⁽¹⁾	WP#=1→0 ⁽¹⁾
-	[000]	0	0	0	[100]	-
-	[001]	0	0	1	[101]	-
[110] ⁽²⁾	[011]	0	1	1	[110]	-
Other than [110] ⁽²⁾					[111]	-
-	[100]	1	0	0	-	[000]
-	[101]	1	0	1	-	[001]
-	[110]	1	1	0	-	[011] ⁽³⁾
-	[111]	1	1	1	-	[011]

NOTES:

1. "WP#=0→1" means that WP# is driven to V_{IH} and "WP#=1→0" means that WP# is driven to V_{IL}.
2. State transition from the current state [011] to the next state depends on the previous state.
3. When WP# is driven to V_{IL} in [110] state, the state changes to [011] and the blocks are automatically locked.
4. In this state transitions table, assumes that lock configuration commands are not written in previous, current and next state.

Table 8. Status Register Definition

R	R	R	R	R	R	R	R
15	14	13	12	11	10	9	8
WSMS	BESS	BEFCES	POPS	VPPS	PSS	DPS	R
7	6	5	4	3	2	1	0

<p>SR.15 - SR.8 = RESERVED FOR FUTURE ENHANCEMENTS (R)</p> <p>SR.7 = WRITE STATE MACHINE STATUS (WSMS) 1 = Ready 0 = Busy</p> <p>SR.6 = BLOCK ERASE SUSPEND STATUS (BESS) 1 = Block Erase Suspended 0 = Block Erase in Progress/Completed</p> <p>SR.5 = BLOCK ERASE AND FULL CHIP ERASE STATUS (BEFCES) 1 = Error in Block Erase or Full Chip Erase 0 = Successful Block Erase or Full Chip Erase</p> <p>SR.4 = PROGRAM AND OTP PROGRAM STATUS (POPS) 1 = Error in Program or OTP Program 0 = Successful Program or OTP Program</p> <p>SR.3 = V_{pp} STATUS (VPPS) 1 = V_{pp} LOW Detect, Operation Abort 0 = V_{pp} OK</p> <p>SR.2 = PROGRAM SUSPEND STATUS (PSS) 1 = Program Suspended 0 = Program in Progress/Completed</p> <p>SR.1 = DEVICE PROTECT STATUS (DPS) 1 = Erase or Program Attempted on a Locked Block, Operation Abort 0 = Unlocked</p> <p>SR.0 = RESERVED FOR FUTURE ENHANCEMENTS (R)</p>	<p>NOTES:</p> <p>Status Register indicates the status of the WSM (Write State Machine).</p> <p>Check SR.7 to determine block erase, full chip erase, program or OTP program completion. SR.6 - SR.1 are invalid while SR.7="0".</p> <p>If both SR.5 and SR.4 are "1"s after a block erase, full chip erase, program, set/clear block lock bit, set block lock-down bit attempt, an improper command sequence was entered.</p> <p>SR.3 does not provide a continuous indication of V_{pp} level. The WSM interrogates and indicates the V_{pp} level only after Block Erase, Full Chip Erase, Program or OTP Program command sequences. SR.3 is not guaranteed to report accurate feedback when V_{pp}≠V_{ppH1}, V_{ppH2} or V_{ppLK}.</p> <p>SR.1 does not provide a continuous indication of block lock bit. The WSM interrogates the block lock bit only after Block Erase, Full Chip Erase, Program or OTP Program command sequences. It informs the system, depending on the attempted operation, if the block lock bit is set. Reading the block lock configuration codes after writing the Read Identifier Codes/OTP command indicates block lock bit status.</p> <p>SR.15 - SR.8 and SR.0 are reserved for future use and should be masked out when polling the status register.</p>
--	---

1 Electrical Specifications

1.1 Absolute Maximum Ratings *

Operating Temperature

During Read, Erase and Program ...-40°C to +85°C (1)

Storage Temperature

During under Bias..... -40°C to +85°C

During non Bias..... -65°C to +125°C

Voltage On Any Pin (except V_{CC}, V_{CCQ} and V_{PP})

.....-0.5V to V_{CCQ}+0.5V (2)

V_{CC} and V_{CCQ} Supply Voltage

-0.2V to +3.9V (2)

V_{PP} Supply Voltage

-0.2V to +12.6V (2, 3, 4)

Output Short Circuit Current

100mA (5)

***WARNING:** Stressing the device beyond the "Absolute Maximum Ratings" may cause permanent damage. These are stress ratings only. Operation beyond the "Operating Conditions" is not recommended and extended exposure beyond the "Operating Conditions" may affect device reliability.

NOTES:

1. Operating temperature is for extended temperature product defined by this specification.
2. All specified voltages are with respect to GND. Minimum DC voltage is -0.5V on input/output pins and -0.2V on V_{CC}, V_{CCQ} and V_{PP} pins. During transitions, this level may undershoot to -2.0V for periods <20ns. Maximum DC voltage on input/output pins is V_{CC}+0.5V which, during transitions, may overshoot to V_{CC}+2.0V for periods <20ns.
3. Maximum DC voltage on V_{PP} may overshoot to +13.0V for periods <20ns.
4. V_{PP} erase/program voltage is normally 2.7V-3.6V. Applying 11.7V-12.3V to V_{PP} during erase/program can be done for a maximum of 1,000 cycles on each block. V_{PP} may be connected to 11.7V-12.3V for a total of 80 hours maximum.
5. Output shorted for no more than one second. No more than one output shorted at a time.

1.2 Operating Conditions

Parameter	Symbol	Min.	Typ.	Max.	Unit	Notes
Operating Temperature	T _A	-40	+25	+85	°C	
V _{CC} Supply Voltage	V _{CC}	2.7	3.0	3.6	V	1
I/O Supply Voltage	V _{CCQ}	2.7	3.0	3.6	V	1
V _{PP} Voltage when Used as a Logic Control	V _{PPH1}	1.65	3.0	3.6	V	1
V _{PP} Supply Voltage	V _{PPH2}	11.7	12.0	12.3	V	1, 2
Block Erase Cycling: V _{PP} =V _{PPH1}		100,000			Cycles	
Block Erase Cycling: V _{PP} =V _{PPH2} , 80 hrs.				1,000	Cycles	
Maximum V _{PP} hours at V _{PPH2}				80	Hours	

NOTES:

1. See DC Characteristics tables for voltage range-specific specification.
2. Applying V_{PP}=11.7V-12.3V during a erase or program can be done for a maximum of 1,000 cycles on each block. A permanent connection to V_{PP}=11.7V-12.3V is not allowed and can cause damage to the device.

1.2.1 Capacitance ⁽¹⁾ ($T_A=+25^\circ\text{C}$, $f=1\text{MHz}$)

Parameter	Symbol	Condition	Min.	Typ.	Max.	Unit
Input Capacitance	C_{IN}	$V_{IN}=0.0\text{V}$		4	7	pF
Output Capacitance	C_{OUT}	$V_{OUT}=0.0\text{V}$		6	10	pF

NOTE:

1. Sampled, not 100% tested.

1.2.2 AC Input/Output Test Conditions

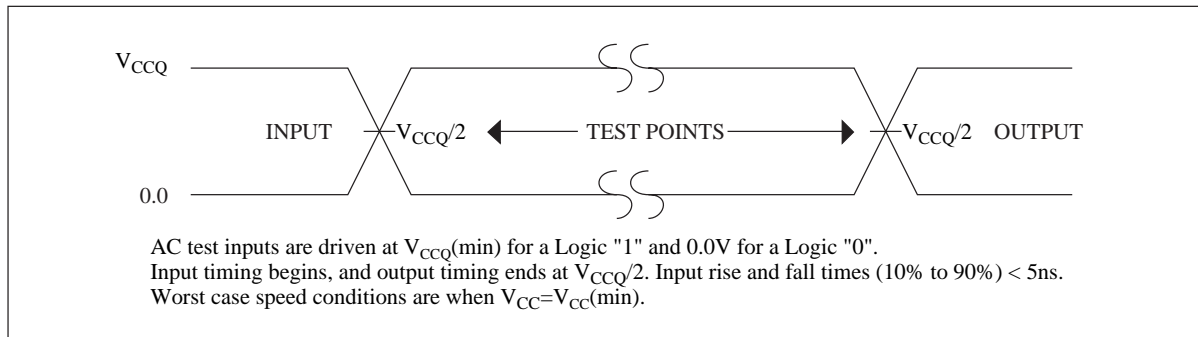

Figure 4. Transient Input/Output Reference Waveform for $V_{CC}=2.7\text{V}-3.6\text{V}$

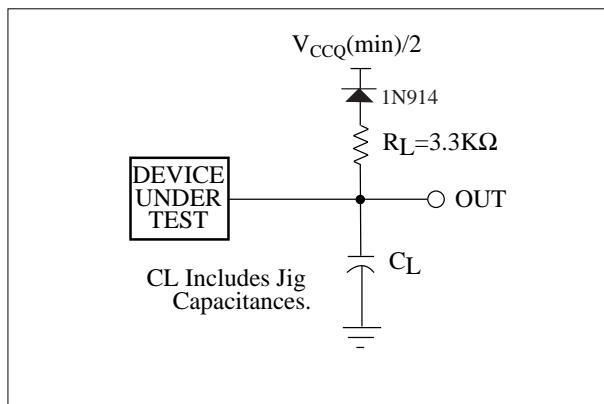

Figure 5. Transient Equivalent Testing Load Circuit

Table 9. Test Configuration Capacitance Loading Value

Test Configuration	C_L (pF)
$V_{CC}=2.7\text{V}-3.6\text{V}$	50

1.2.3 DC Characteristics

$V_{CC}=2.7V-3.6V$

Symbol	Parameter	Notes	Min.	Typ.	Max.	Unit	Test Conditions
I_{LI}	Input Load Current	1	-1.0		+1.0	μA	$V_{CC}=V_{CCMax.}$,
I_{LO}	Output Leakage Current	1	-1.0		+1.0	μA	$V_{CCQ}=V_{CCQMax.}$, $V_{IN}/V_{OUT}=V_{CCQ}$ or GND
I_{CCS}	V_{CC} Standby Current	1,7		4	10	μA	$V_{CC}=V_{CCMax.}$, $CE\#=RST\#$ = $V_{CCQ}\pm 0.2V$, $WP\#=V_{CCQ}$ or GND
I_{CCAS}	V_{CC} Automatic Power Savings Current	1,4,7		4	10	μA	$V_{CC}=V_{CCMax.}$, $CE\#=GND\pm 0.2V$, $WP\#=V_{CCQ}$ or GND
I_{CCD}	V_{CC} Reset Current	1,7		4	10	μA	$RST\#=GND\pm 0.2V$
I_{CCR}	V_{CC} Read Current	1,7			17	mA	$V_{CC}=V_{CCMax.}$, $CE\#=V_{IL}$, $OE\#=V_{IH}$, $f=5MHz$
I_{CCW}	V_{CC} Program Current	1,5,7		20	60	mA	$V_{PP}=V_{PPH1}$
		1,5,7		10	20	mA	$V_{PP}=V_{PPH2}$
I_{CCE}	V_{CC} Block Erase, Full Chip Erase Current	1,5,7		10	30	mA	$V_{PP}=V_{PPH1}$
		1,5,7		4	10	mA	$V_{PP}=V_{PPH2}$
I_{CCWS} I_{CCES}	V_{CC} Program or Block Erase Suspend Current	1,2,7		10	200	μA	$CE\#=V_{IH}$
I_{PPS} I_{PPR}	V_{PP} Standby or Read Current	1,6,7		2	5	μA	$V_{PP}\leq V_{CC}$
I_{PPW}	V_{PP} Program Current	1,5,6,7		2	5	μA	$V_{PP}=V_{PPH1}$
		1,5,6,7		10	30	mA	$V_{PP}=V_{PPH2}$
I_{PPE}	V_{PP} Block Erase, Full Chip Erase Current	1,5,6,7		2	5	μA	$V_{PP}=V_{PPH1}$
		1,5,6,7		5	15	mA	$V_{PP}=V_{PPH2}$
I_{PPWS}	V_{PP} Program Suspend Current	1,6,7		2	5	μA	$V_{PP}=V_{PPH1}$
		1,6,7		10	200	μA	$V_{PP}=V_{PPH2}$
I_{PPES}	V_{PP} Block Erase Suspend Current	1,6,7		2	5	μA	$V_{PP}=V_{PPH1}$
		1,6,7		10	200	μA	$V_{PP}=V_{PPH2}$

DC Characteristics (Continued)

$V_{CC}=2.7V-3.6V$

Symbol	Parameter	Notes	Min.	Typ.	Max.	Unit	Test Conditions
V_{IL}	Input Low Voltage	5	-0.4		0.4	V	
V_{IH}	Input High Voltage	5	2.4		$V_{CCQ} + 0.4$	V	
V_{OL}	Output Low Voltage	5			0.2	V	$V_{CC}=V_{CCMin.}$, $V_{CCQ}=V_{CCQMin.}$, $I_{OL}=100\mu A$
V_{OH}	Output High Voltage	5	$V_{CCQ} - 0.2$			V	$V_{CC}=V_{CCMin.}$, $V_{CCQ}=V_{CCQMin.}$, $I_{OH}=-100\mu A$
V_{PPLK}	V_{PP} Lockout during Normal Operations	3,5,6			0.4	V	
V_{PPH1}	V_{PP} during Block Erase, Full Chip Erase, Program or OTP Program Operations	6	1.65	3.0	3.6	V	
V_{PPH2}	V_{PP} during Block Erase, Full Chip Erase, Program or OTP Program Operations	6	11.7	12.0	12.3	V	
V_{LKO}	V_{CC} Lockout Voltage		1.5			V	

NOTES:

- All currents are in RMS unless otherwise noted. Typical values are the reference values at $V_{CC}=3.0V$, $V_{CCQ}=3.0V$ and $T_A=+25^\circ C$ unless V_{CC} is specified.
- I_{CCWS} and I_{CCES} are specified with the device de-selected. If read or program is executed while in block erase suspend mode, the device's current draw is the sum of I_{CCES} and I_{CCR} or I_{CCW} . If read is executed while in program suspend mode, the device's current draw is the sum of I_{CCWS} and I_{CCR} .
- Block erase, full chip erase, program and OTP program are inhibited when $V_{PP} \leq V_{PPLK}$, and not guaranteed in the range between $V_{PPLK}(max.)$ and $V_{PPH1}(min.)$, between $V_{PPH1}(max.)$ and $V_{PPH2}(min.)$, and above $V_{PPH2}(max.)$.
- The Automatic Power Savings (APS) feature automatically places the device in power save mode after read cycle completion. Standard address access timings (t_{AVQV}) provide new data when addresses are changed.
- Sampled, not 100% tested.
- V_{PP} is not used for power supply pin. With $V_{PP} \leq V_{PPLK}$, block erase, full chip erase, program and OTP program cannot be executed and should not be attempted.
Applying $12.0V \pm 0.3V$ to V_{PP} provides fast erasing or fast programming mode. In this mode, V_{PP} is power supply pin and supplies the memory cell current for block erasing and programming. Use similar power supply trace widths and layout considerations given to the V_{CC} power bus.
Applying $12.0V \pm 0.3V$ to V_{PP} during erase/program can only be done for a maximum of 1,000 cycles on each block. V_{PP} may be connected to $12.0V \pm 0.3V$ for a total of 80 hours maximum.
- For all pins other than those shown in test conditions, input level is V_{CCQ} or GND.

1.2.4 AC Characteristics - Read-Only Operations⁽¹⁾

$$V_{CC}=2.7V-3.6V, T_A=-40^{\circ}C \text{ to } +85^{\circ}C$$

Symbol	Parameter	Notes	Min.	Max.	Unit
t _{AVAV}	Read Cycle Time		90		ns
t _{AVQV}	Address to Output Delay			90	ns
t _{ELQV}	CE# to Output Delay	3		90	ns
t _{GLQV}	OE# to Output Delay	3		20	ns
t _{PHQV}	RST# High to Output Delay			150	ns
t _{EHQZ} , t _{GHQZ}	CE# or OE# to Output in High Z, Whichever Occurs First	2		20	ns
t _{ELQX}	CE# to Output in Low Z	2	0		ns
t _{GLQX}	OE# to Output in Low Z	2	0		ns
t _{OH}	Output Hold from First Occurring Address, CE# or OE# change	2	0		ns

NOTES:

1. See AC input/output reference waveform for timing measurements and maximum allowable input slew rate.
2. Sampled, not 100% tested.
3. OE# may be delayed up to t_{ELQV} — t_{GLQV} after the falling edge of CE# without impact to t_{ELQV}.

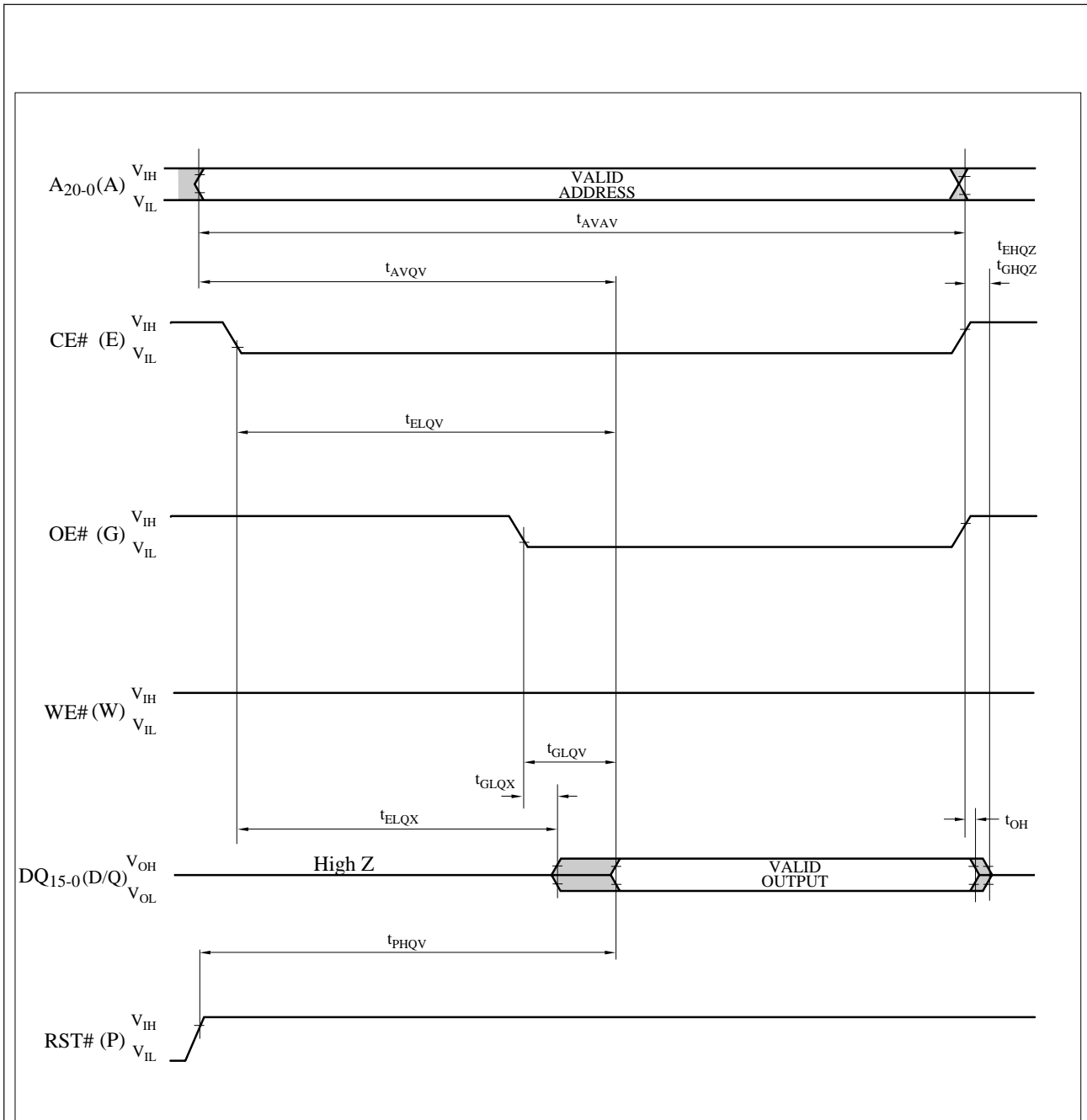

Figure 6. AC Waveform for Read Operations

1.2.5 AC Characteristics - Write Operations^{(1), (2)}

$$V_{CC}=2.7V-3.6V, T_A=-40^{\circ}C \text{ to } +85^{\circ}C$$

Symbol	Parameter	Notes	Min.	Max.	Unit
t_{AVAV}	Write Cycle Time		90		ns
t_{PHWL} (t_{PHEL})	RST# High Recovery to WE# (CE#) Going Low	3	150		ns
t_{ELWL} (t_{WLEL})	CE# (WE#) Setup to WE# (CE#) Going Low		0		ns
t_{WLWH} (t_{ELEH})	WE# (CE#) Pulse Width	4	60		ns
t_{DVWH} (t_{DVEH})	Data Setup to WE# (CE#) Going High	8	40		ns
t_{AVWH} (t_{AVEH})	Address Setup to WE# (CE#) Going High	8	50		ns
t_{WHEH} (t_{EHWH})	CE# (WE#) Hold from WE# (CE#) High		0		ns
t_{WHDX} (t_{EHDX})	Data Hold from WE# (CE#) High		0		ns
t_{WHAX} (t_{EHAX})	Address Hold from WE# (CE#) High		0		ns
t_{WHWL} (t_{EHEL})	WE# (CE#) Pulse Width High	5	30		ns
t_{SHWH} (t_{SHEH})	WP# High Setup to WE# (CE#) Going High	3	0		ns
t_{VVWH} (t_{VVEH})	V_{PP} Setup to WE# (CE#) Going High	3	200		ns
t_{WHGL} (t_{EHGL})	Write Recovery before Read		30		ns
t_{QVSL}	WP# High Hold from Valid SRD	3, 6	0		ns
t_{QVVL}	V_{PP} Hold from Valid SRD	3, 6	0		ns
t_{WHR0} (t_{EHR0})	WE# (CE#) High to SR.7 Going "0"	3, 7		$t_{AVQV}+50$	ns

NOTES:

1. The timing characteristics for reading the status register during block erase, full chip erase, program and OTP program operations are the same as during read-only operations. Refer to AC Characteristics for read-only operations.
2. A write operation can be initiated and terminated with either CE# or WE#.
3. Sampled, not 100% tested.
4. Write pulse width (t_{WP}) is defined from the falling edge of CE# or WE# (whichever goes low last) to the rising edge of CE# or WE# (whichever goes high first). Hence, $t_{WP}=t_{WLWH}=t_{ELEH}=t_{WLEH}=t_{ELWH}$.
5. Write pulse width high (t_{WPH}) is defined from the rising edge of CE# or WE# (whichever goes high first) to the falling edge of CE# or WE# (whichever goes low last). Hence, $t_{WPH}=t_{WHWL}=t_{EHEL}=t_{WHEL}=t_{EHWL}$.
6. V_{PP} should be held at $V_{PP}=V_{PPH1/2}$ until determination of block erase, full chip erase, program or OTP program success (SR.1/3/4/5=0).
7. t_{WHR0} (t_{EHR0}) after the Read Query or Read Identifier Codes/OTP command= $t_{AVQV}+100ns$.
8. Refer to Table 4 for valid address and data for block erase, full chip erase, program, OTP program or lock bit configuration.

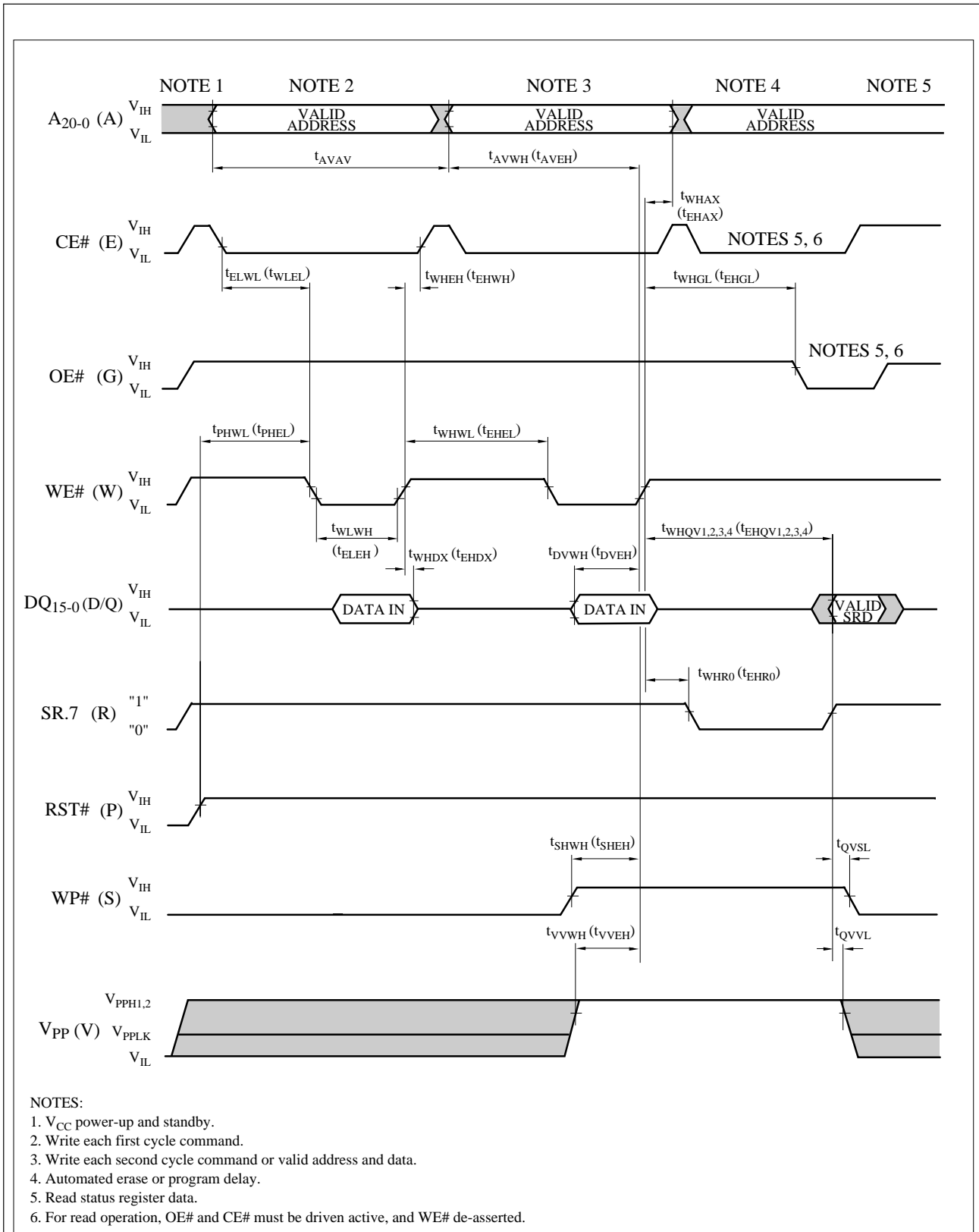

Figure 7. AC Waveform for Write Operations

1.2.6 Reset Operations

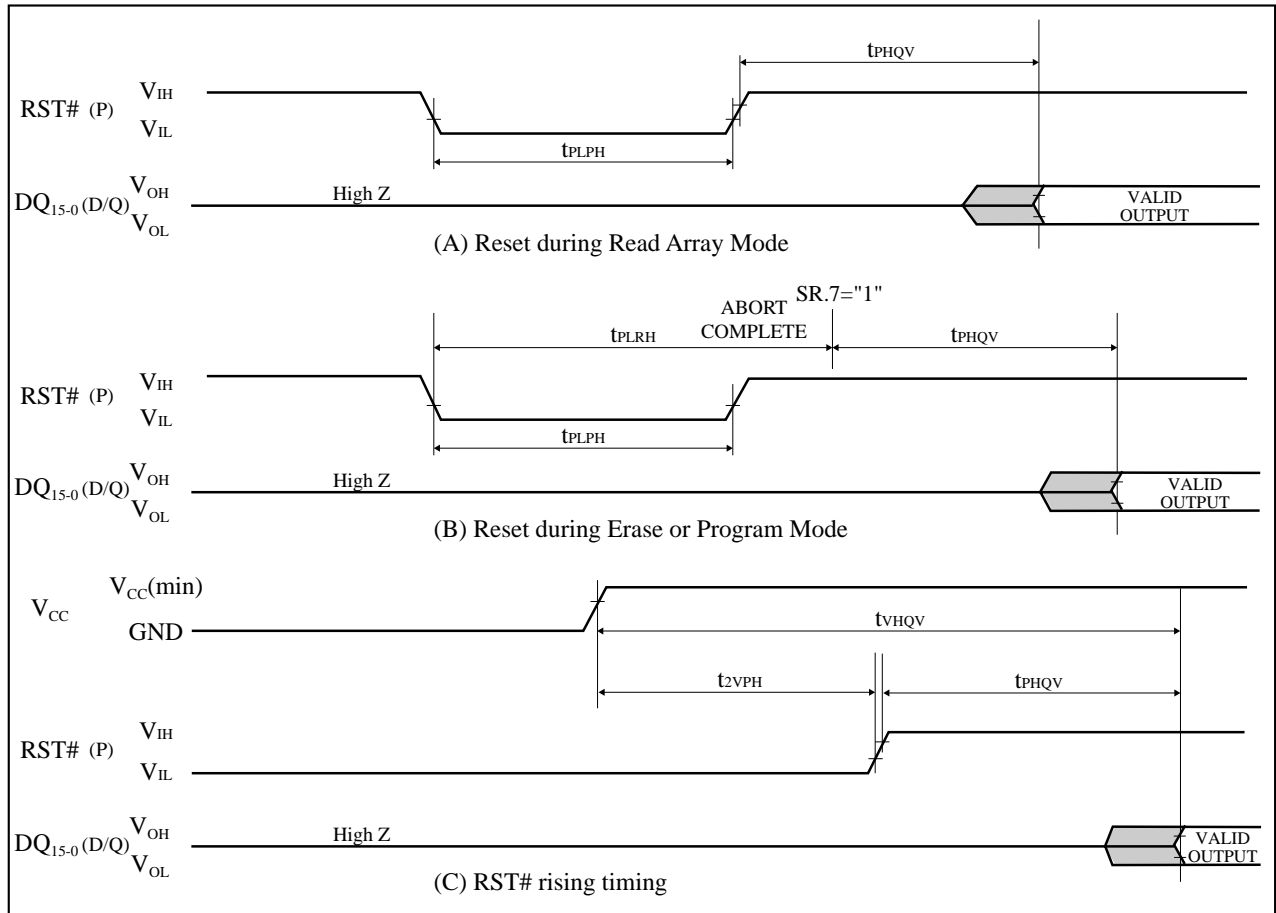

Figure 8. AC Waveform for Reset Operations

Reset AC Specifications ($V_{CC}=2.7V-3.6V$, $T_A=-40^{\circ}C$ to $+85^{\circ}C$)

Symbol	Parameter	Notes	Min.	Max.	Unit
t_{PLPH}	RST# Low to Reset during Read (RST# should be low during power-up.)	1, 2, 3	100		ns
t_{PLRH}	RST# Low to Reset during Erase or Program	1, 3, 4		22	μs
t_{2VPH}	V_{CC} 2.7V to RST# High	1, 3, 5	100		ns
t_{VHQV}	V_{CC} 2.7V to Output Delay	3		1	ms

NOTES:

1. A reset time, t_{PHQV} , is required from the later of SR.7 going "1" or RST# going high until outputs are valid. Refer to AC Characteristics - Read-Only Operations for t_{PHQV} .
2. t_{PLPH} is <100ns the device may still reset but this is not guaranteed.
3. Sampled, not 100% tested.
4. If RST# asserted while a block erase, full chip erase, program or OTP program operation is not executing, the reset will complete within 100ns.
5. When the device power-up, holding RST# low minimum 100ns is required after V_{CC} has been in predefined range and also has been in stable there.

1.2.7 Block Erase, Full Chip Erase, Program and OTP Program Performance⁽³⁾

$$V_{CC}=2.7V-3.6V, T_A=-40^{\circ}C \text{ to } +85^{\circ}C$$

Symbol	Parameter	Notes	V _{PP} =V _{PPH1} (In System)			V _{PP} =V _{PPH2} (In Manufacturing)			Unit
			Min.	Typ. ⁽¹⁾	Max. ⁽²⁾	Min.	Typ. ⁽¹⁾	Max. ⁽²⁾	
t _{WPB}	4-Kword Parameter Block Program Time	2		0.05	0.3		0.04	0.12	s
t _{WMB1}	32-Kword Block Program Time	2		0.34	2.4		0.31	1.0	s
t _{WMB2}	64-Kword Block Program Time	2		0.68	4.8		0.62	2.0	s
t _{WHQV1} / t _{EHQV1}	Word Program Time	2		10	200		9	185	μs
t _{WHOV1} / t _{EHOV1}	OTP Program Time	2		36	400		27	185	μs
t _{WHQV2} / t _{EHQV2}	4-Kword Parameter Block Erase Time	2		0.26	4		0.2	4	s
t _{WHQV3} / t _{EHQV3}	32-Kword Block Erase Time	2		0.51	5		0.5	5	s
t _{WHQV4} / t _{EHQV4}	64-Kword Block Erase Time	2		0.82	8		0.8	8	s
	Full Chip Erase Time	2		40	350		33	350	s
t _{WHRH1} / t _{EHRH1}	Program Suspend Latency Time to Read	4		5	10		5	10	μs
t _{WHRH2} / t _{EHRH2}	Block Erase Suspend Latency Time to Read	4		5	20		5	20	μs
t _{ERES}	Latency Time from Block Erase Resume Command to Block Erase Suspend Command	5	500			500			μs

NOTES:

1. Typical values measured at V_{CC}=3.0V, V_{PP}=3.0V or 12.0V, and T_A=+25°C. Assumes corresponding lock bits are not set. Subject to change based on device characterization.
2. Excludes external system-level overhead.
3. Sampled, but not 100% tested.
4. A latency time is required from writing suspend command (WE# or CE# going high) until SR.7 going "1".
5. If the interval time from a Block Erase Resume command to a subsequent Block Erase Suspend command is shorter than t_{ERES} and its sequence is repeated, the block erase operation may not be finished.

2 Related Document Information⁽¹⁾

Document No.	Document Name
FUM03802	LHF00LXX series Appendix

NOTE:

1. International customers should contact their local SHARP or distribution sales offices.

3 Package and packing specification

[Applicability]

This specification applies to IC package of the LEAD-FREE delivered as a standard specification.

1.Storage Conditions.

1-1.Storage conditions required before opening the dry packing.

- Normal temperature : 5~40°C
- Normal humidity : 80%(Relative humidity) max.
- * "Humidity" means "Relative humidity"

1-2.Storage conditions required after opening the dry packing.

In order to prevent moisture absorption after opening, ensure the following storage conditions apply:

- (1) Storage conditions for one-time soldering. (Convection reflow^{*1}, IR/Convection reflow.^{*1}, or Manual soldering.)
 - Temperature : 5~25°C
 - Humidity : 60% max.
 - Period : 72 hours max. after opening.
 - (2) Storage conditions for two-time soldering. (Convection reflow^{*1}, IR/Convection reflow.^{*1})
 - a. Storage conditions following opening and prior to performing the 1st reflow.
 - Temperature : 5~25°C
 - Humidity : 60% max.
 - Period : 72 hours max. after opening.
 - b. Storage conditions following completion of the 1st reflow and prior to performing the 2nd reflow.
 - Temperature : 5~25°C
 - Humidity : 60% max.
 - Period : 72 hours max. after completion of the 1st reflow.
- ^{*1}:Air or nitrogen environment.

1-3.Temporary storage after opening.

To re-store the devices before soldering, do so only once and use a dry box or place desiccant (with a blue humidity indicator) with the devices and perform dry packing again using heat-sealing.

The storage period, temperature and humidity must be as follows :

(1) Storage temperature and humidity.

※1 : External atmosphere temperature and humidity of the dry packing.

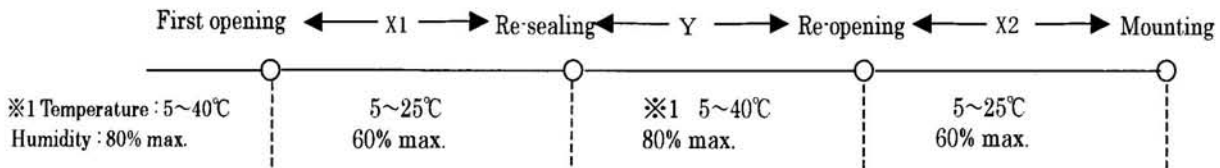

(2) Storage period.

- X1 + X2 : Refer to Section 1-2(1) and (2)a , depending on the mounting method.
- Y : Two weeks max.

2. Baking Condition.

(1) Situations requiring baking before mounting.

- Storage conditions exceed the limits specified in Section 1-2 or 1-3.
- Humidity indicator in the desiccant was already red (pink) when opened.
(Also for re-opening.)

(2) Recommended baking conditions.

- Baking temperature and period :
120°C for 16~24 hours.
- The above baking conditions apply since the trays are heat-resistant.

(3) Storage after baking.

- After baking, store the devices in the environment specified in Section 1-2 and mount immediately.

3. Surface mount conditions.

The following soldering condition are recommended to ensure device quality.

3-1.Soldering.

(1) Convection reflow or IR/Convection. (one-time soldering or two-time soldering in air or nitrogen environment)

- Temperature and period :

A) Peak temperature.	250°C max.
B) Heating temperature.	40 to 60 seconds as 220°C
C) Preheat temperature.	It is 150 to 200°C, and is 120±30 seconds
D) Temperature increase rate.	It is 1 to 3°C/seconds
- Measuring point : IC package surface.
- Temperature profile:

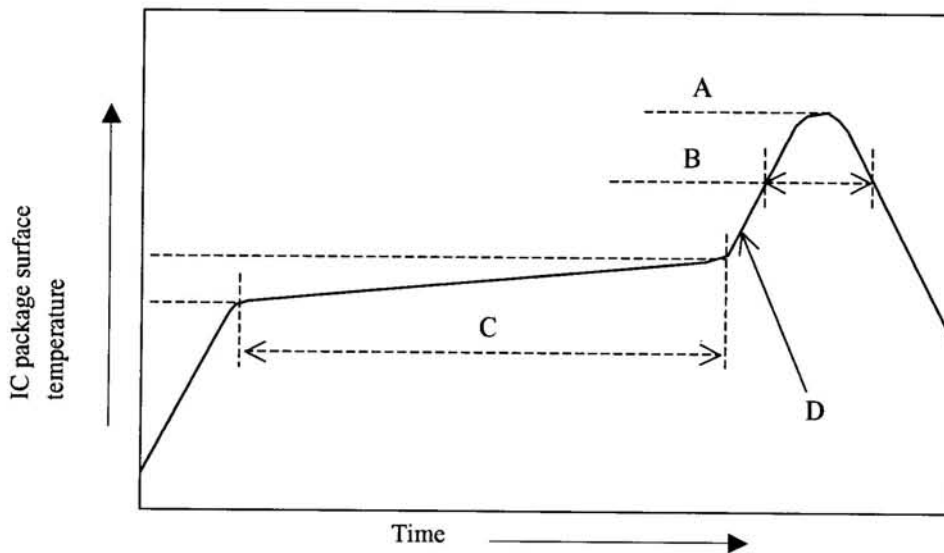

(2) Manual soldering (soldering iron) (one-time soldering only)

Soldering iron should only touch the IC's outer leads.

- Temperature and period :
350°C max. for 3 seconds / pin max.
(Soldering iron should only touch the IC's outer leads.)
- Measuring point : Soldering iron tip.

4. Condition for removal of residual flux.

- (1) Ultrasonic washing power : 25 watts / liter max.
- (2) Washing time : Total 1 minute max.
- (3) Solvent temperature : 15~40°C

5. Package outline specification.

Refer to the attached drawing.

(Plastic body dimensions do not include burr of resin.)

The contents of LEAD-FREE TYPE application of the specifications. (*2)

6. Markings.

6-1. Marking details. (The information on the package should be given as follows.)

- (1) Product name : LHF00L13
- (2) Company name : SHARP
- (3) Date code

(Example) YY WW XXX

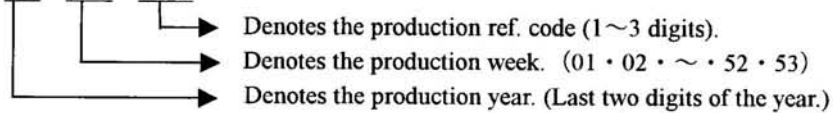

- (4) "JAPAN" indicates the country of origin.

6-2. Marking layout.

The layout is shown in the attached drawing.

(However, this layout does not specify the size of the marking character and marking position.)

*2 The contents of LEAD-FREE TYPE application of the specifications.

LEAD FINISH or BALL TYPE	LEAD-FREE TYPE (Sn-Bi)
DATE CODE	They are those with an underline under YYWW XXX
The word of " LEAD FREE" is printed on the packing label	Printed

(Note) It is those with an underline printing in a date code because of a LEAD-FREE type.

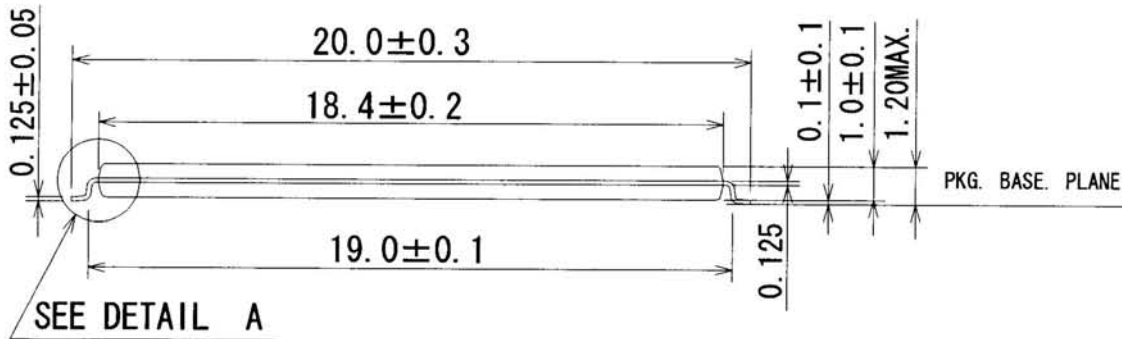
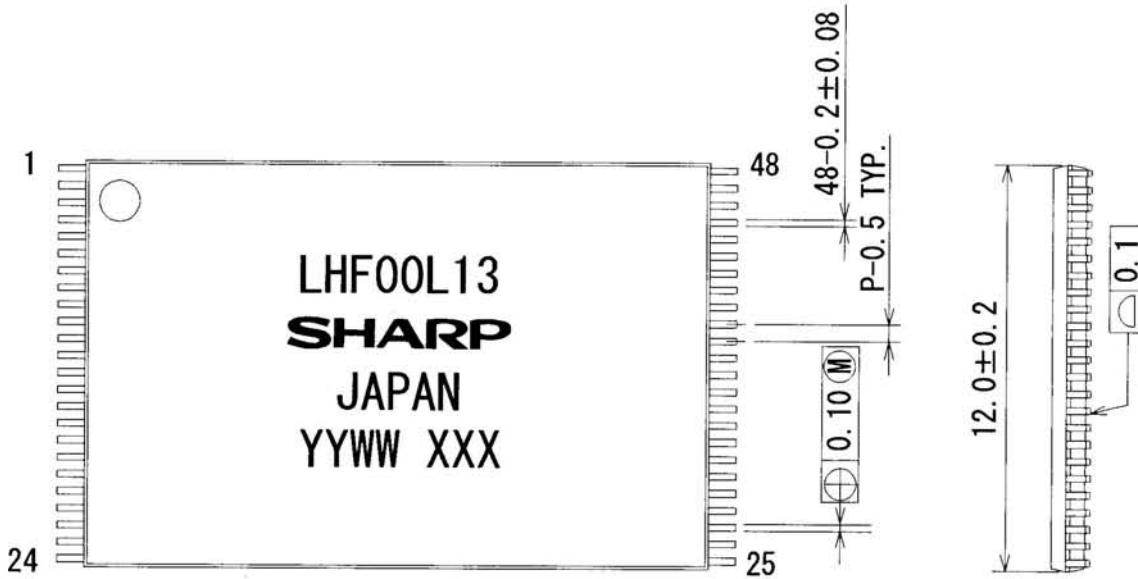

SEE DETAIL A

DETAIL A

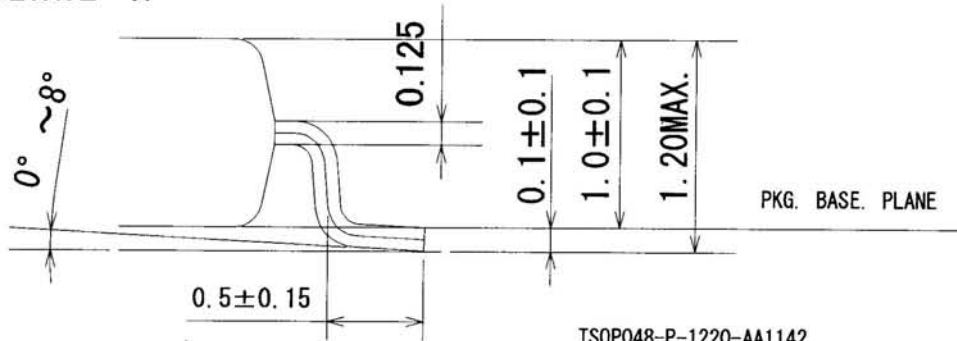

TSOP048-P-1220-AA1142

LEAD TYPE	LEAD FINISH		LEAD MATERIAL
	Sn-Bi PLATING		42Alloy
NAME	TSOP048-P-1220		NOTE : Plastic body dimensions do not include burr of resin.
DRAWING NO.	AA1142	UNIT mm	

7. Packing Specifications (Dry packing for surface mount packages.)

7-1. Packing materials.

Material name	Material specifications	Purpose
Inner carton	Cardboard (960 devices / inner carton max.)	Packing the devices. (10 trays / inner carton)
Tray	Conductive plastic (96 devices / tray)	Securing the devices.
Upper cover tray	Conductive plastic (1 tray / inner carton)	Securing the devices.
Laminated aluminum bag	Aluminum polyethylene	Keeping the devices dry.
Desiccant	Silica gel	Keeping the devices dry.
Label	Paper	Indicates part number, quantity, and packed date.
PP band	Polypropylene (3 pcs. / inner carton)	Securing the devices.
Outer carton	Cardboard (3840 devices / outer carton max.)	Outer packing.

(Devices must be placed on the tray in the same direction.)

7-2. Outline dimension of tray.

Refer to the attached drawing.

7-3. Outline dimension of carton.

Refer to the attached drawing.

8. Precautions for use.

- (1) Opening must be done on an anti-ESD treated workbench.
All workers must also have undergone anti-ESD treatment.
- (2) The trays have undergone either conductive or anti-ESD treatment.
If another tray is used, make sure it has also undergone conductive or anti-ESD treatment.
- (3) The devices should be mounted the devices within one year of the date of delivery.

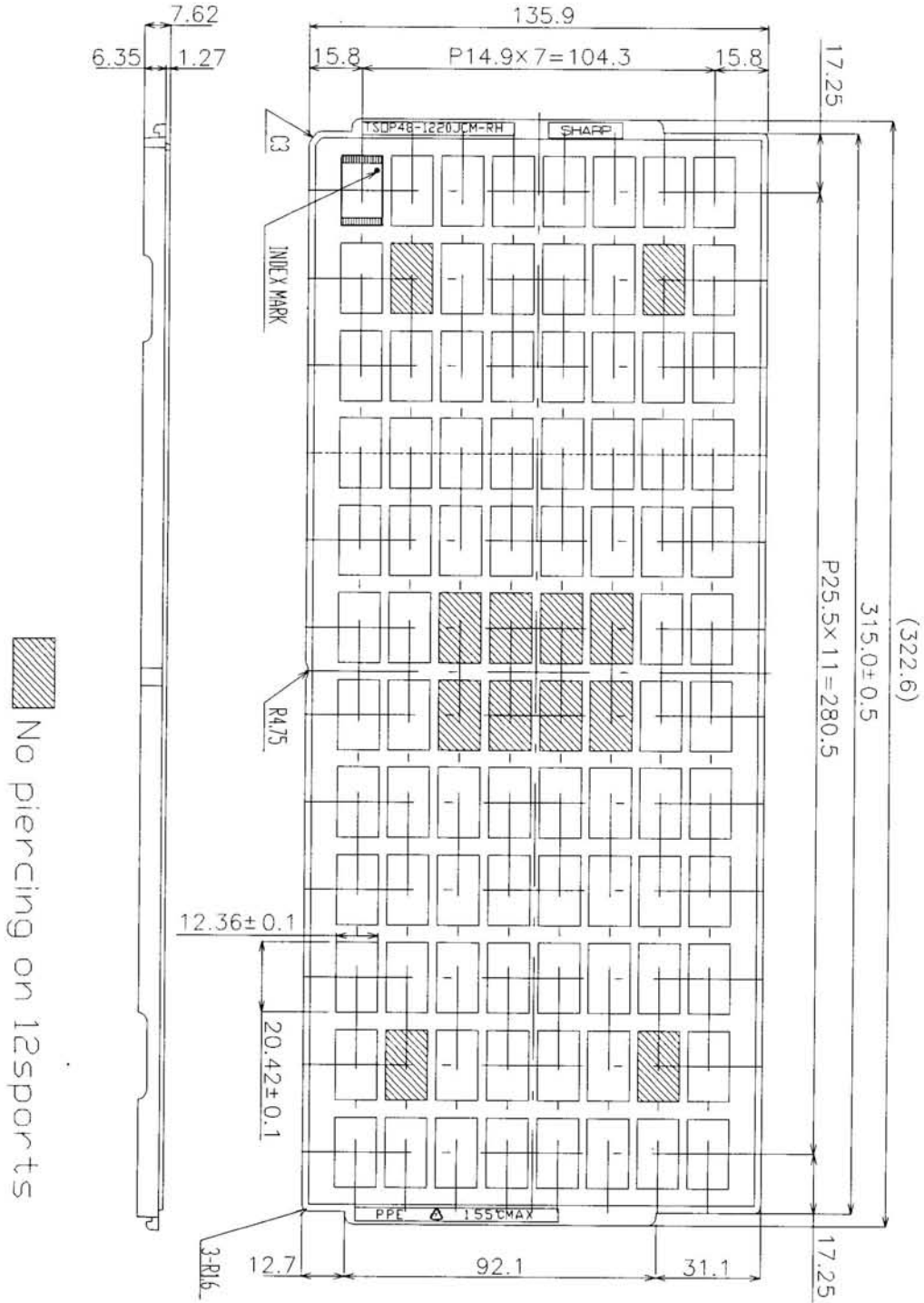

名称 NAME	TSOP48-1220JCM-RH-N		備考 NOTE
DRAWING NO.	CV911	単位 UNIT	mm

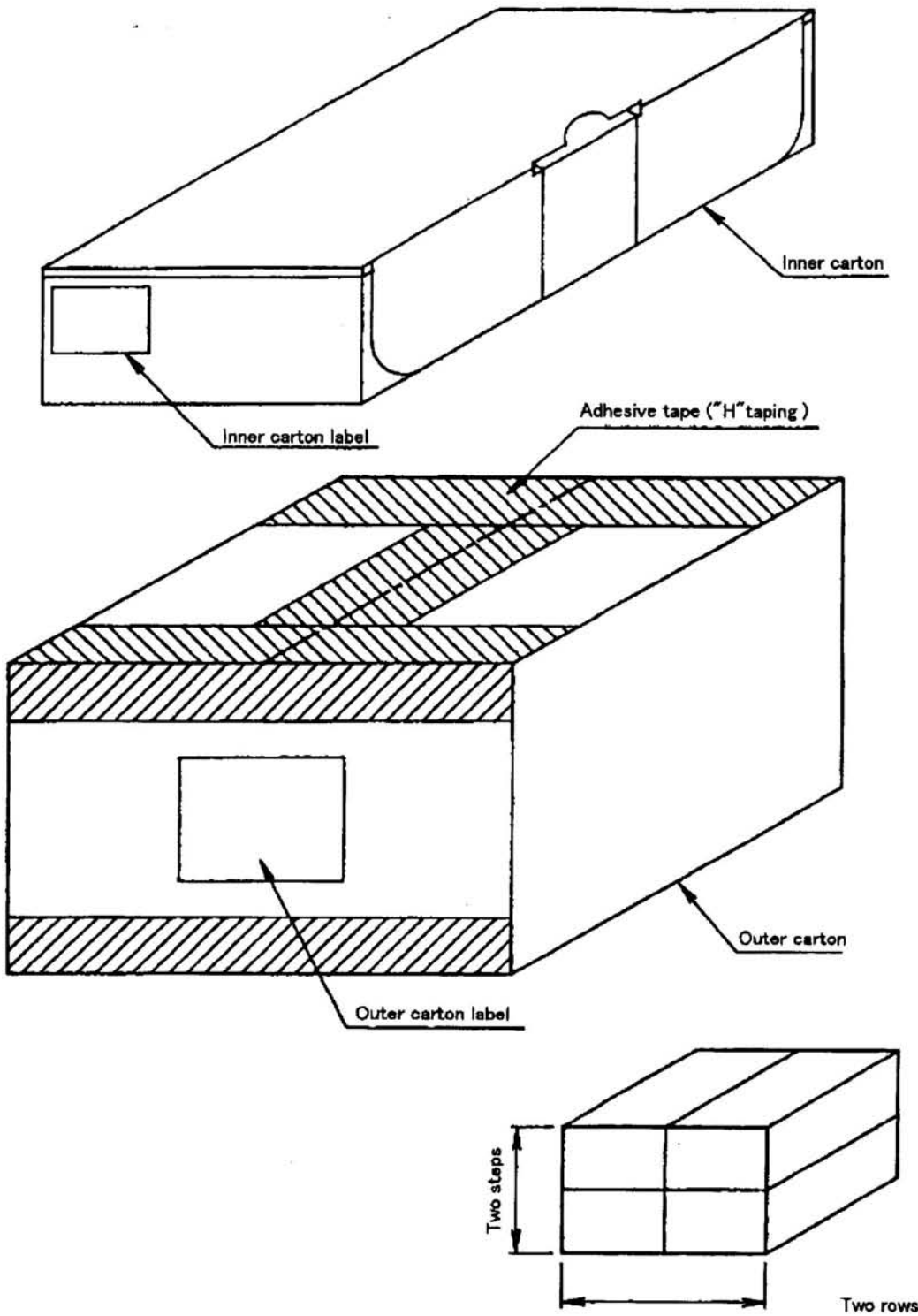

L × W × H

Inner carton - Outer dimensions : 335 × 150 × 80

Outer carton - Outer dimensions : 340 × 310 × 175

名称 NAME	トレイ品 包装仕様 Packing specifications		備考 NOTE
DRAWING NO.	BJ433	単位 UNIT	
		mm	出荷数量が端数の場合、本仕様と異なることがあります。 There is a possibility different from this specification when the number of shipments is fractions.

20040310

(Note) The <LEAD-FREE> display shows a lead-free article.

Inner carton label

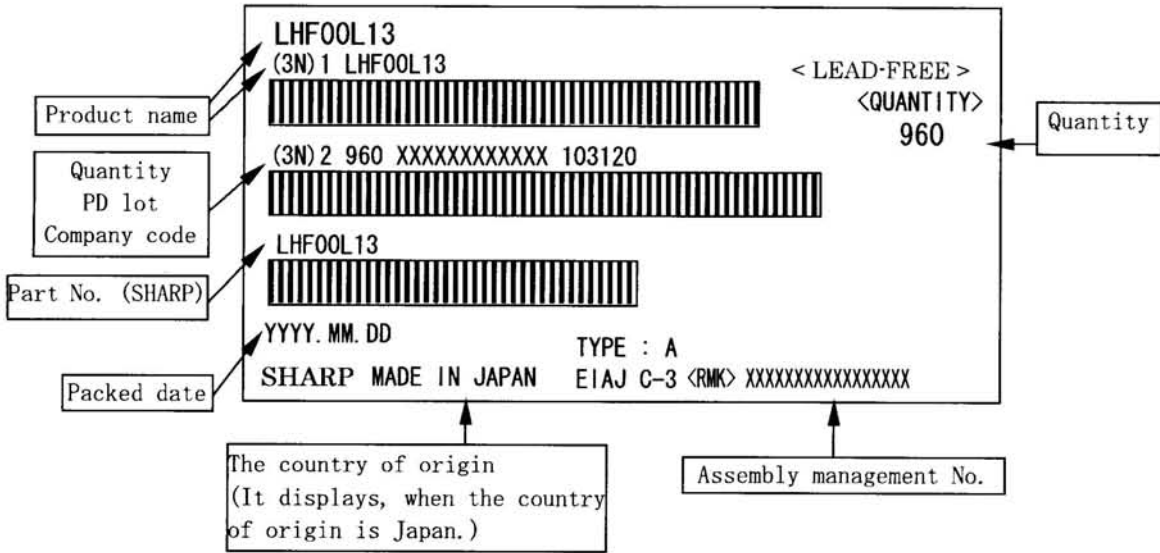

Outer carton label

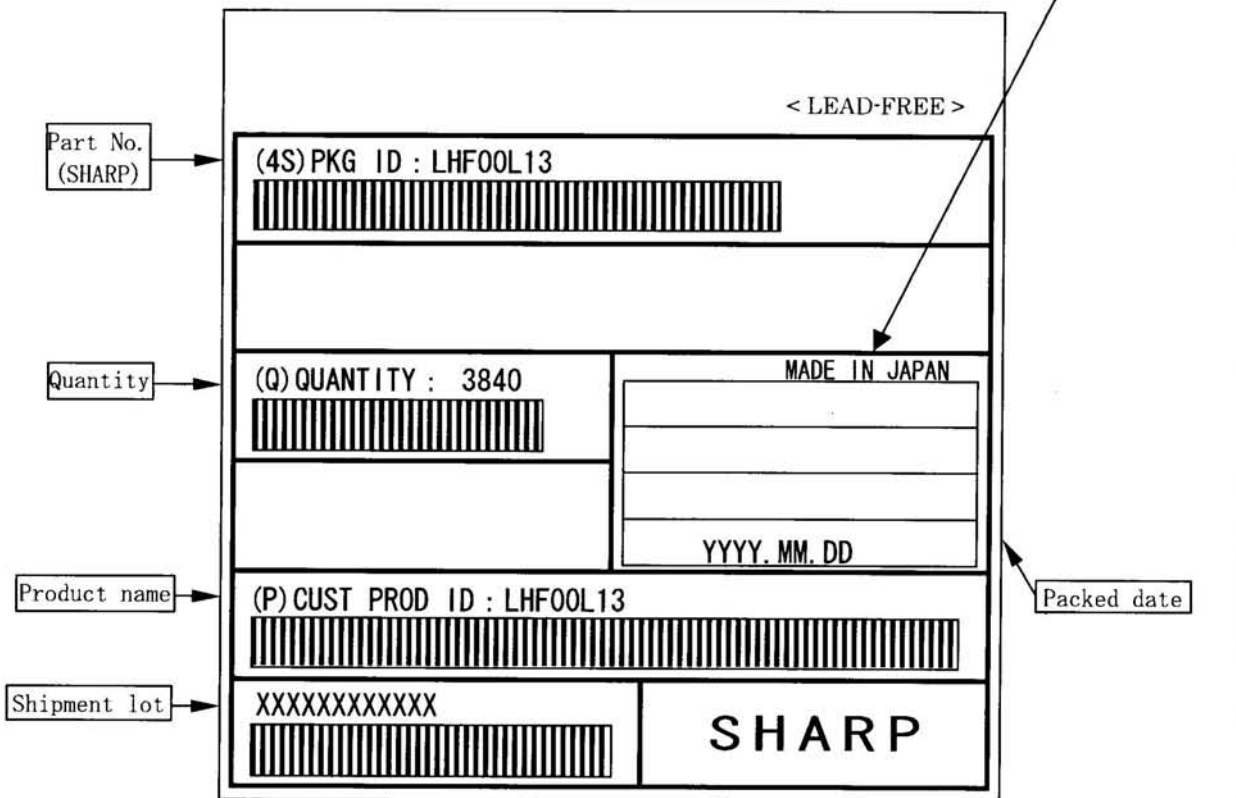

(Former) EIAJ B Standard conforming

A-1 RECOMMENDED OPERATING CONDITIONS

A-1.1 At Device Power-Up

AC timing illustrated in Figure A-1 is recommended for the supply voltages and the control signals at device power-up. If the timing in the figure is ignored, the device may not operate correctly.

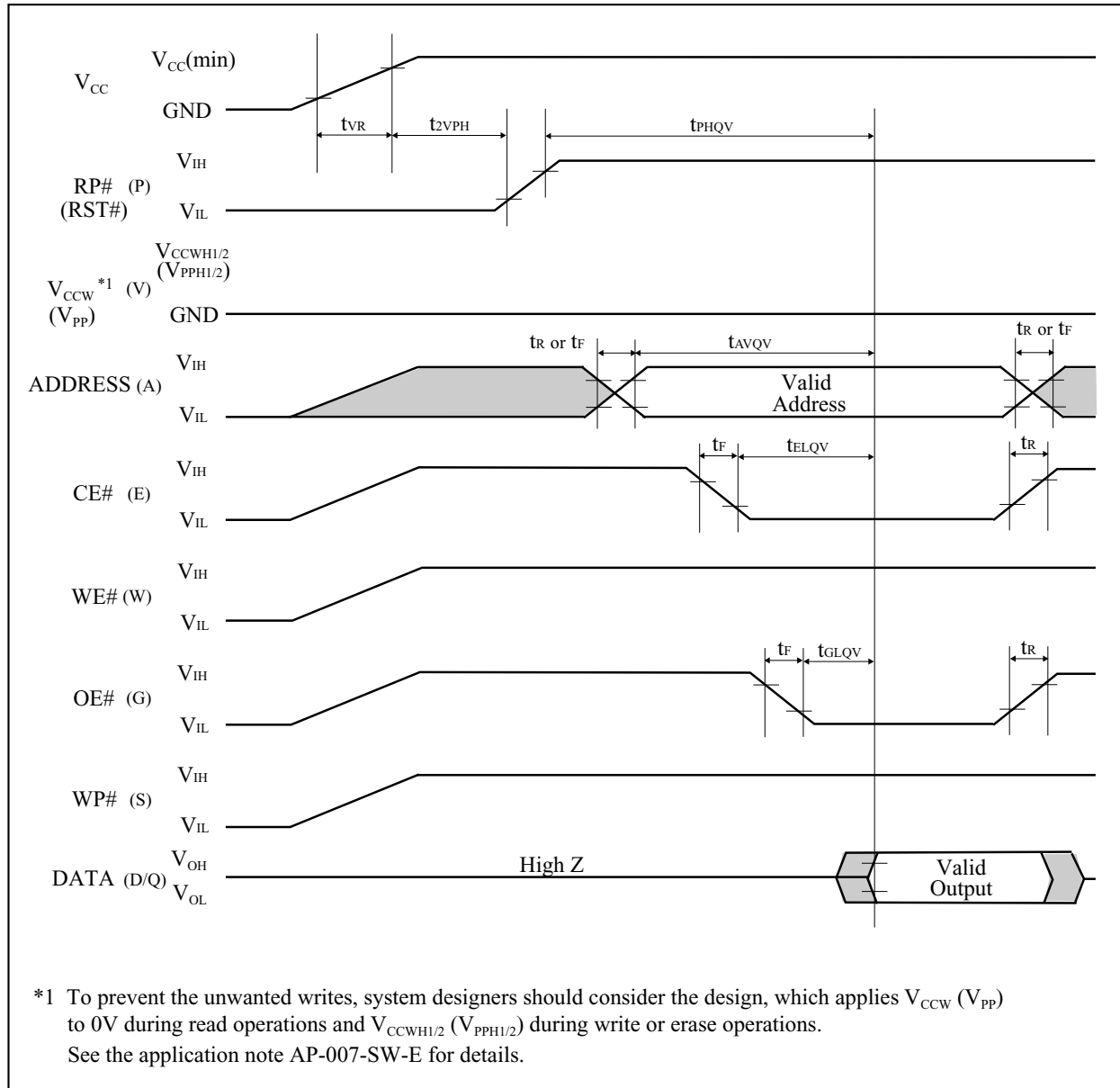

Figure A-1. AC Timing at Device Power-Up

For the AC specifications t_{VR} , t_r , t_f in the figure, refer to the next page. See the “ELECTRICAL SPECIFICATIONS” described in specifications for the supply voltage range, the operating temperature and the AC specifications not shown in the next page.

A-1.1.1 Rise and Fall Time

Symbol	Parameter	Notes	Min.	Max.	Unit
t_{VR}	V_{CC} Rise Time	1	0.5	30000	$\mu\text{s}/\text{V}$
t_R	Input Signal Rise Time	1, 2		1	$\mu\text{s}/\text{V}$
t_F	Input Signal Fall Time	1, 2		1	$\mu\text{s}/\text{V}$

NOTES:

1. Sampled, not 100% tested.
2. This specification is applied for not only the device power-up but also the normal operations.

A-1.2 Glitch Noises

Do not input the glitch noises which are below V_{IH} (Min.) or above V_{IL} (Max.) on address, data, reset, and control signals, as shown in Figure A-2 (b). The acceptable glitch noises are illustrated in Figure A-2 (a).

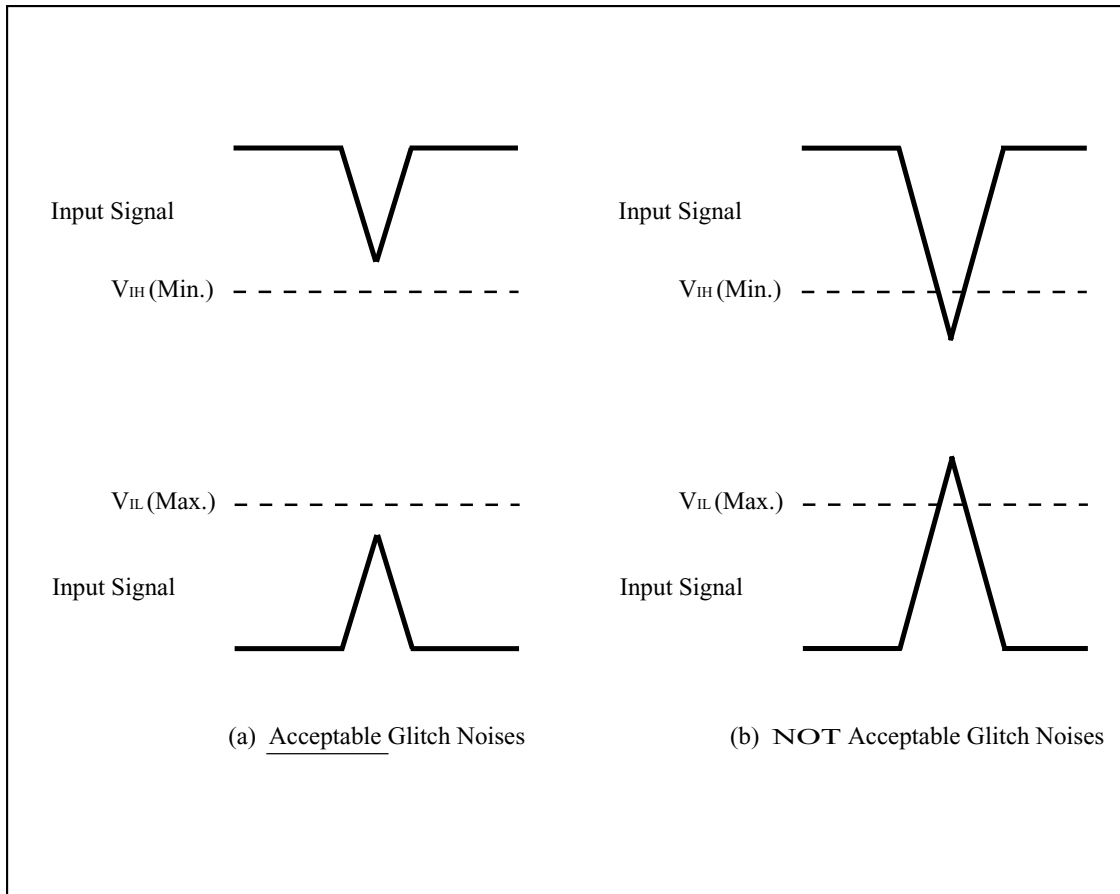

Figure A-2. Waveform for Glitch Noises

See the “DC CHARACTERISTICS” described in specifications for V_{IH} (Min.) and V_{IL} (Max.).

A-2 RELATED DOCUMENT INFORMATION⁽¹⁾

Document No.	Document Name
AP-001-SD-E	Flash Memory Family Software Drivers
AP-006-PT-E	Data Protection Method of SHARP Flash Memory
AP-007-SW-E	RP#, V _{pp} Electric Potential Switching Circuit

NOTE:

1. International customers should contact their local SHARP or distribution sales office.

SPECIFICATIONS ARE SUBJECT TO CHANGE WITHOUT NOTICE.

Suggested applications (if any) are for standard use; See Important Restrictions for limitations on special applications. See Limited Warranty for SHARP's product warranty. The Limited Warranty is in lieu, and exclusive of, all other warranties, express or implied. ALL EXPRESS AND IMPLIED WARRANTIES, INCLUDING THE WARRANTIES OF MERCHANTABILITY, FITNESS FOR USE AND FITNESS FOR A PARTICULAR PURPOSE, ARE SPECIFICALLY EXCLUDED. In no event will SHARP be liable, or in any way responsible, for any incidental or consequential economic or property damage.

SHARP®**NORTH AMERICA**

SHARP Microelectronics of the Americas
5700 NW Pacific Rim Blvd.
Camas, WA 98607, U.S.A.
Phone: (1) 360-834-2500
Fax: (1) 360-834-8903
Fast Info: (1) 800-833-9437
www.sharpsma.com

EUROPE

SHARP Microelectronics Europe
Division of Sharp Electronics (Europe) GmbH
Sonninstrasse 3
20097 Hamburg, Germany
Phone: (49) 40-2376-2286
Fax: (49) 40-2376-2232
www.sharpsme.com

JAPAN

SHARP Corporation
Electronic Components & Devices
22-22 Nagaike-cho, Abeno-Ku
Osaka 545-8522, Japan
Phone: (81) 6-6621-1221
Fax: (81) 6117-725300/6117-725301
www.sharp-world.com

TAIWAN

SHARP Electronic Components
(Taiwan) Corporation
8F-A, No. 16, Sec. 4, Nanking E. Rd.
Taipei, Taiwan, Republic of China
Phone: (886) 2-2577-7341
Fax: (886) 2-2577-7326/2-2577-7328

SINGAPORE

SHARP Electronics (Singapore) PTE., Ltd.
438A, Alexandra Road, #05-01/02
Alexandra Technopark,
Singapore 119967
Phone: (65) 271-3566
Fax: (65) 271-3855

KOREA

SHARP Electronic Components
(Korea) Corporation
RM 501 Geosung B/D, 541
Dohwa-dong, Mapo-ku
Seoul 121-701, Korea
Phone: (82) 2-711-5813 ~ 8
Fax: (82) 2-711-5819

CHINA

SHARP Microelectronics of China
(Shanghai) Co., Ltd.
28 Xin Jin Qiao Road King Tower 16F
Pudong Shanghai, 201206 P.R. China
Phone: (86) 21-5854-7710/21-5834-6056
Fax: (86) 21-5854-4340/21-5834-6057

Head Office:

No. 360, Bashen Road,
Xin Development Bldg. 22
Waigaoqiao Free Trade Zone Shanghai
200131 P.R. China
Email: smc@china.global.sharp.co.jp

HONG KONG

SHARP-ROXY (Hong Kong) Ltd.
3rd Business Division,
17/F, Admiralty Centre, Tower 1
18 Harcourt Road, Hong Kong
Phone: (852) 28229311
Fax: (852) 28660779
www.sharp.com.hk

Shenzhen Representative Office:

Room 13B1, Tower C,
Electronics Science & Technology Building
Shen Nan Zhong Road
Shenzhen, P.R. China
Phone: (86) 755-3273731
Fax: (86) 755-3273735