

Based on the demand from rail roads and transit authorities, Dialight now offers a collection of products specifically designed to accommodate the needs of the railroad industry. All of these products utilize the latest LED technology, are highly durable, and are direct replacements for incandescent lighting.



### LED Track Signals

LED Track Signaling was developed by Dialight specifically for retrofit applications where replacement of existing incandescent light bulbs is desired. Installation is nearly as simple as replacement of the incandescent bulb.

### 891 Series LED 5 1/4 WAYSIDE SIGNAL LAMP MODULE

The 891 Series LED Wayside Signal Lamp Modules were developed by Dialight specifically for use in new and retrofit applications for transit railroad 5 1/4 signals. Installation is nearly as simple as replacement of the incandescent bulb. Dialight lamp modules have been fully qualified for the Rail environment and incorporate power factor correction and total harmonic distortion reduction circuitry.

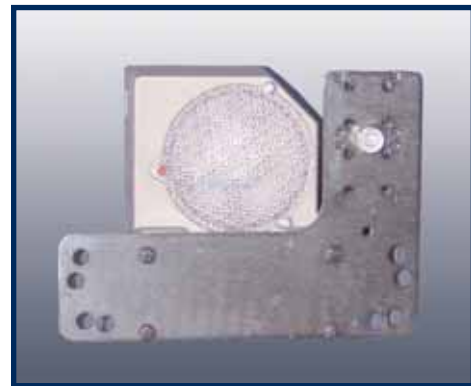

### 15MM RIGHT ANGLE BASED LED

Single and double sided LED based solutions are available to easily replace incandescent fixtures with LED in gate arms and other rail signaling housings.



### Dialight Corporation

1501 Route 34 South • Farmingdale, NJ 07727 USA

Tel: (1) 732.919.3119 • Fax: (1) 732.751.5778 • [www.dialight.com](http://www.dialight.com)



## High Intensity LED Panel Mount Indicators 556 Series for 1" Mounting Hole Watertight



### FEATURES / BENEFITS

- ▲ InGaN and AlInGaP technology
- ▲ Long life, lasting 100,000 hours
- ▲ Wide viewing angle feature of domed lens
- ▲ Low profile flat lens
- ▲ Multi LED construction
- ▲ Uniform illumination
- ▲ Daylight viewable
- ▲ High durability
- ▲ Tamperproof

PART NUMBER	COLOR	LENS STYLE	VOLTAGE	CURRENT (mA)	TYPICAL INTENSITY (fL)
556-3508-304	Red	Dome	37.5 DC	20	1000
556-3608-304	Green	Dome	37.5 DC	16	1800
556-3708-304	Yellow	Dome	37.5 DC	20	1000
556-1508-304	Red	Flat	37.5 DC	20	2600
556-1608-304	Green	Flat	37.5 DC	16	4000
556-1708-304	Yellow	Flat	37.5 DC	20	2600
556-3506-304	Red	Dome	74 DC	10	700
556-3606-304	Green	Dome	74 DC	10	1000
556-3706-304	Yellow	Dome	74 DC	10	700
556-3507-304	Red	Dome	125 DC	10	700
556-3607-304	Green	Dome	125 DC	10	1000
556-3707-304	Yellow	Dome	125 DC	10	700

### PRODUCT SPECIFICATIONS

- ▲ Housing material: nickel plated brass
- ▲ Lens material: polycarbonate 94-VO
- ▲ Storage temperature: -40°C to +100°C
- ▲ Operating temperature: -30°C to +85°C
- ▲ Front mounting in 1" clearance hole
- ▲ Watertight seal from front of panel meets NEMA 4X IP 66

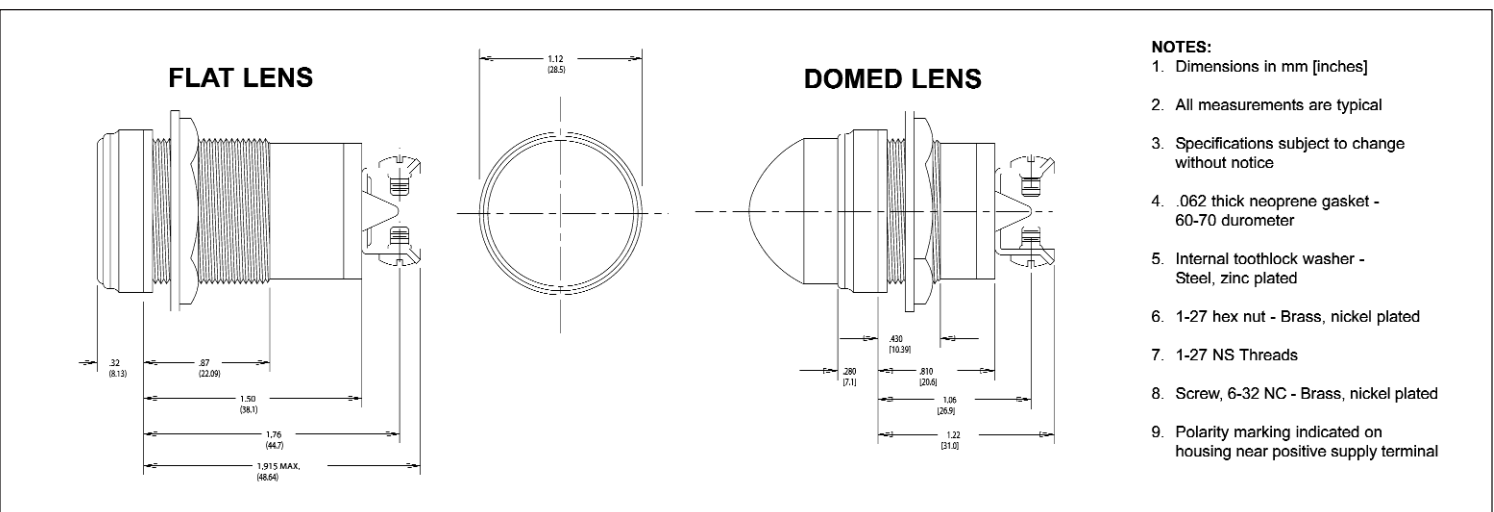

IMPROVED  
LOW WATTAGE  
DESIGN

## 433 SERIES LED RAIL CROSSING SIGNAL MODULE

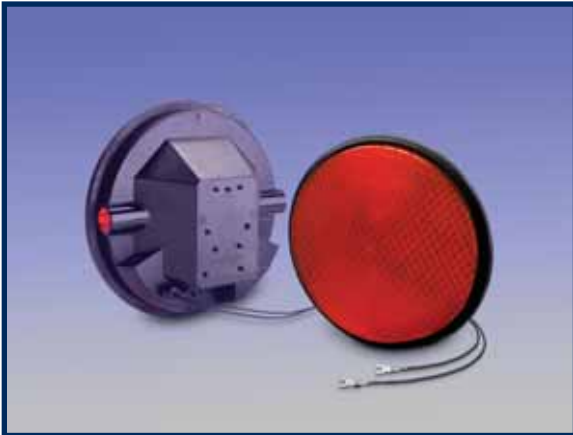

The state-of-the-art 433 Series is unique from other LED crossing lights in several ways: (1) Diffused lens and uniform appearance are similar to incandescent, (2) the lamp maintains the specified light output down to 9 volts, but operates down as low as 5 volts, and (3) safety is increased by side lights that monitor the main light beam by reflecting light via patented light pipe technology to ensure train engineers that the light aspect facing the street is actually flashing, providing two less failure points compared to any other competitor product!

## 892 SERIES LED 8<sup>3</sup>/<sub>8</sub> WAYSIDE SIGNAL LAMP MODULE

The 892 Series LED Wayside Signal Lamp Modules were developed by Dialight specifically for use in Class 1 Railroad, 8<sup>3</sup>/<sub>8</sub>" signals in retrofit applications where replacement of existing incandescent light bulbs is desired. This installation approach provides all the benefits of LEDs without the complex retrofit of the entire lens and housing assemblies.



## P46 SERIES 5 1/2" Round Rail Car LED Marker Lamp



**Certification:**  
Federal Railroad Administration (FRA) - Part 221

### FEATURES / BENEFITS

- ▲ High vibration resistance
- ▲ Longer life-25k hours
- ▲ Reduced current draw
- ▲ Transient voltage protected
- ▲ Durable hard coated polycarbonate lens
- ▲ Rugged cast aluminum housing
- ▲ 24 to 90 VDC operating range
- ▲ CO1 comes with screw terminals on rear of lamp
- ▲ CO3 comes with fast-on connections
- ▲ Rubber grommet included for enclosure seal

### SPECIFICATIONS

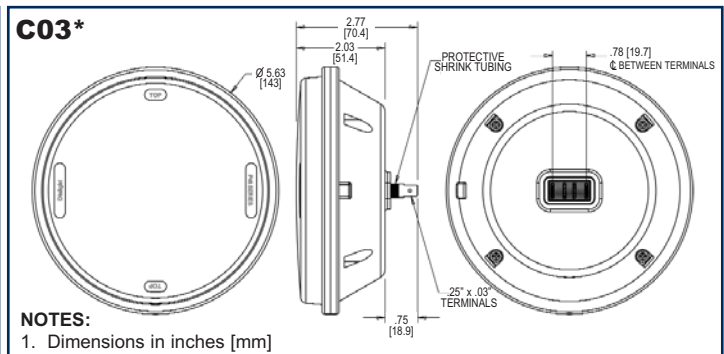
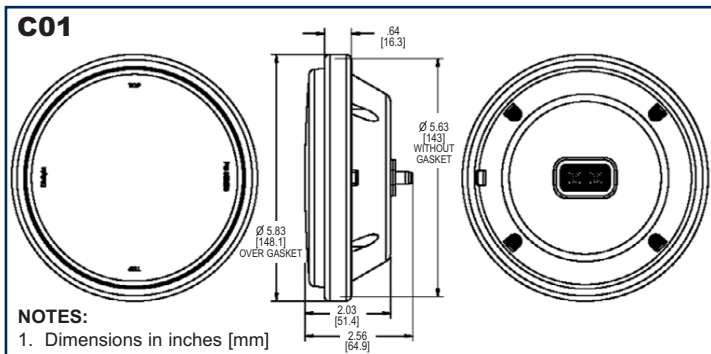

Part Number	Description	Typical Current	Color
P46-1R05-C01	24 – 90 Volts DC	500 mAmps@ 36 VDC	RED
P46-1R05-C03*	24 – 90 Volts DC	500 mAmps@ 36 VDC	RED

\* fast-on connections

**Other products are available.  
Please contact your Dialight Sales Representative  
for more information.**



**Dialight Corporation**

1501 Route 34 South • Farmingdale, NJ 07727 USA

Tel: (1) 732.919.3119 • Fax: (1) 732.751.5778 • www.dialight.com



MBELCARX001\_C