

512 bit Read/Write Contactless Identification Device

General Description

EM4469 and EM4569 are CMOS RFID integrated circuits intended for use in electronic Read/Write RF transponders.

The RFID IC is powered by picking the energy from a continuous 125 kHz magnetic field via an external coil, which together with the integrated capacitor form a resonant circuit. The IC read out data from its internal EEPROM and sends it out by switching on and off a resistive load in parallel to the coil. Commands and EEPROM data updates can be executed by 100% AM modulation of the 125 kHz magnetic field.

There are several data rate and data encoding options available. Options are stored in EEPROM Configuration word. Read and write access to EEPROM can be protected by 32-bit password. All EEPROM words can be write protected by setting lock bits which transform them in read-only.

It contains factory programmed and locked 32 bit UID number, chip type and customer code.

EM4569 is completely compatible with EM4469. However, EM4569 has bumped enlarged pads intended for direct connection of coil to big bumps. EM4569 also has an extended reading range which makes it particularly suitable for animal tracking applications.

Features

- Extended reading range (EM4569)
- 512 bit EEPROM organised in 16 words of 32 bits
- 32 bit Password read and write protection
- 32 bit unique identification number (UID)
- 10 bit Customer code
- ISO 11784 / 11785 Standard Compliant
- Bumped enlarged pads (EM4569 only)
- Lock feature convert EEPROM words in read only
- Multi-purpose encoding (Manchester, Biphase, Miller, PSK, FSK)
- Multi-purpose data rate from 1 up to 32k baud
- 100 to 150 kHz frequency range
- On-chip rectifier and voltage limiter
- No external supply buffer capacitor needed
- 40 to +85°C temperature range
- Very low Power consumption
- Resonant capacitor integrated on chip (330pF, 250pF or 75pF mask option)

Applications

- Access Control
- Animal Identification according to ISO FDX-B (EM4569)
- Material Logistics

Typical Operating Configuration

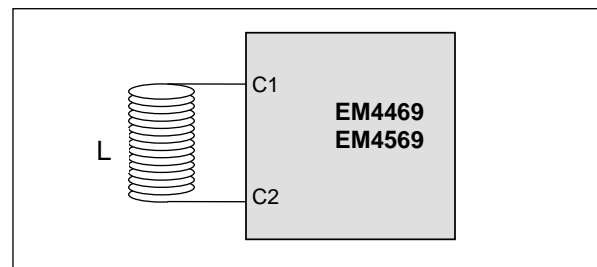

Fig. 1

Block Diagram

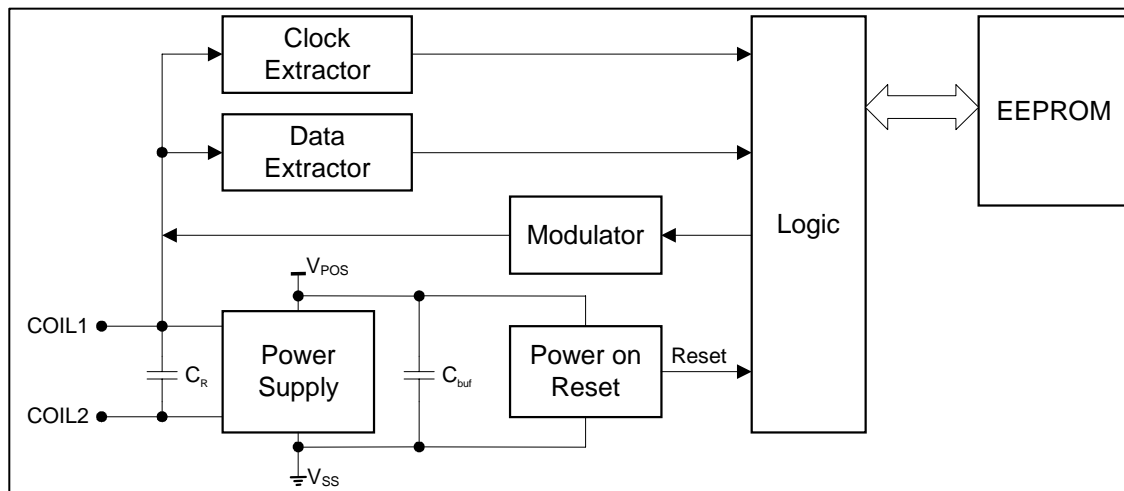

Fig. 2