

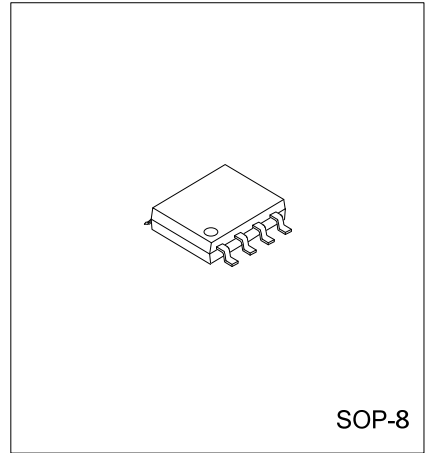

P3586

LINEAR INTEGRATED CIRCUIT

PWM CONTROL 3A STEP-DOWN CONVERTER



DESCRIPTION

The UTC **P3586** is a fixed 1.2MHz frequency, voltage mode, PWM controller with an internal power MOSFET. It supplies 3A continuous output current over a wide input supply range with excellent load and line regulation.

An internal reference voltage source provides low output voltage down to 0.8V for further applications. A PWM control circuit can provide 0~100% duty ratio.

The reliability of UTC **P3586** achieved by such protection circuits. An UVLO (Under voltage lock output) circuit monitors the VCC supply voltage to prevent wrong logic controls. The controller's OCP (Over current protection) circuit monitors the output current by using the voltage drop across the power MOSFET's R_{DS} saving the use of a current sensing resistor. Over current protection circuit also monitors the voltage on FB pin under short-circuit conditions.

The UTC **P3586** is generally applied in portable devices. For maximum flexibility in determining loop dynamic, this device is equipped with compensation pin. In addition, it is requiring less external components for operation due to its configuration.

FEATURES

- * 3A Output Current
- * 1.2MHz Frequency
- * Input Voltage Range: 3.6V to 23V
- * 10 μ A Shutdown Supply Current
- * Output Voltage Varies from 0.8V to VCC
- * Frequency fold back at Short Circuit
- * Protection Circuits:
UVLO, Thermal Shutdown, OCP
- * Low ESR Output Capacitor (Multi-Layer Chip Capacitor (MLCC)) Application.
- * Halogen Free

ORDERING INFORMATION

Ordering Number	Package	Packing
P3586G-S08-R	SOP-8	Tape Reel

<p>P3586G-S08-R</p> <ul style="list-style-type: none"> (1) Packing Type (2) Package Type (3) Halogen Free 	<ul style="list-style-type: none"> (1) R: Tape Reel (2) S08: SOP-8 (3) G: Halogen Free
--	---

■ PIN CONFIGURATION

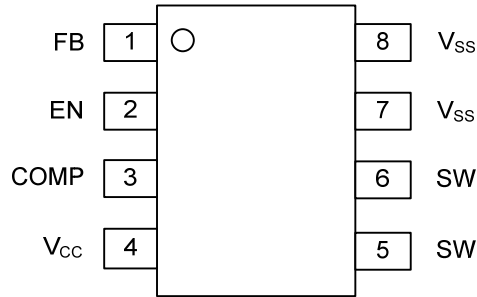

■ PIN DESCRIPTION

PIN NO.	PIN NAME	DESCRIPTION
1	FB	Feedback pin-An external resistor divider from the output to GND, tapped to the FB pin sets the output voltage.
2	EN	Regulator On/Off Control pin. A high input at EN turns on the converter, and a low input turns it off.
3	COMP	Compensation pin- This node is the output of the error amplifier and the input to PWM comparator.
4	V _{CC}	Input Supply Pin.
5, 6	SW	Power Switch Output pin
7, 8	V _{SS}	GND pin

■ BLOCK DIAGRAM

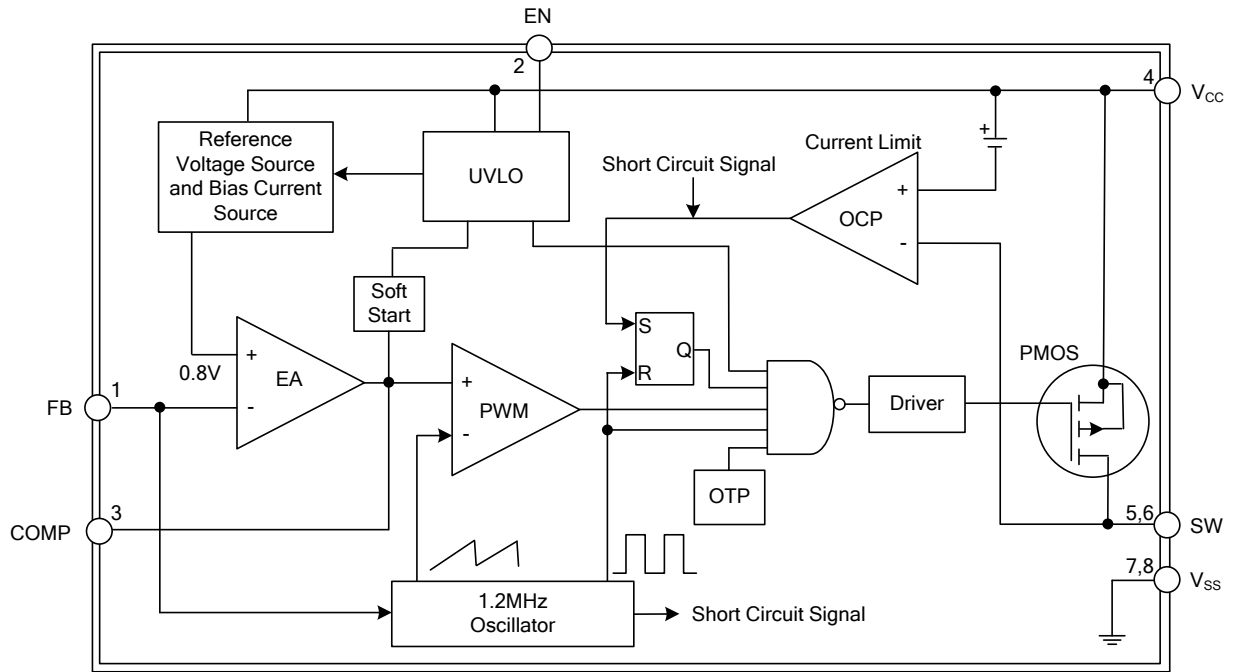

■ ABSOLUTE MAXIMUM RATING (Ta=25°C, unless otherwise specified)

PARAMETER	SYMBOL	RATINGS	UNIT
V _{CC} Pin Voltage	V _{CC}	-0.3 ~ +23	V
Feedback Pin Voltage	V _{FB}	-0.3 ~ +6	V
ON/OFF Pin Voltage	V _{EN}	- 0.3 ~ V _{CC} +0.3	V
Switch Pin Voltage	V _{SW}	- 0.3 ~ V _{CC} + 0.3	V
Operating Supply Voltage	V _{OP}	+3.6 ~ +20	V
Power Dissipation	P _D	Internally limited	mW
Operating Junction Temperature	T _J	-20 ~ +125	°C
Storage Temperature	T _{STG}	-40 ~ +150	°C

Note: Absolute maximum ratings are those values beyond which the device could be permanently damaged. Absolute maximum ratings are stress ratings only and functional device operation is not implied.

■ THERMAL DATA

PARAMETER	SYMBOL	RATINGS	UNIT
Junction to Ambient	θ_{JA}	70	°C/W
Junction to Case	θ_{JC}	25	°C/W

Notes: θ_{JA} is measured with the PCB copper area(need connect to SW pins) of approximately 1 in²(Multi-layer)

■ ELECTRICAL CHARACTERISTICS (V_{IN} = 12V, Ta= 25°C, unless otherwise specified.)

PARAMETER	SYMBOL	TEST CONDITIONS	MIN	TYP	MAX	UNIT
Feedback Voltage	V _{FB}	I _{OUT} =0.1A	0.784	0.80	0.816	V
Feedback Bias Current	I _{FB(BIAS)}	I _{OUT} =0.1A		0.1	0.5	μA
Switch Current	I _{SW}	Pear current, No outside circuit V _{FB} =0.7V Force driver on	3.2	4.5		A
Standby Current	I _{STN-BY}	V _{EN} =0V No outside circuit V _{FB} =0V Force driver on			10	μA
Quiescent Current	I _Q	V _{FB} =1.2V Force driver off		3	5	mA
Oscillation Frequency	f _{OSC}	Measure waveform at SW Pin	1.0	1.2	1.4	MHz
Frequency of Current Limit or Short Circuit Protect	f _{OSC1}	Measure waveform at SW Pin	70	90	120	KHz
Line Regulation	$\frac{\Delta V_{OUT}}{V_{OUT}}$	V _{CC} =5V-20V, I _{OUT} =0.2A		1	2	%
Load Regulation	$\frac{\Delta V_{OUT}}{V_{OUT}}$	I _{OUT} =0.2A-3A		0.2	0.5	%
EN Pin Input Current	I _{SH}	V _{EN} =2.5V(ON)			30	μA
	I _{SL}	V _{EN} =0.3V(OFF)		0	1	μA
Internal MOSFET R _{DS(ON)}	R _{DS(ON)}	V _{CC} =5V, V _{FB} =0V		110	150	mΩ
		V _{CC} =12V, V _{FB} =0V		70	100	mΩ
EN Pin Logic input threshold voltage	V _{SH}	High(regulator ON)	2.0			V
	V _{SL}	Low(regulator OFF)			0.8	V
Thermal Shutdown Temp	TSD			160		°C
Efficiency	EFFI.	V _{IN} = 12V, V _{OUT} = 5V, I _{OUT} = 3A		88		%
Soft Start Time	T _{SS}		0.3	2	5	mS

■ TYPICAL APPLICATION CIRCUIT

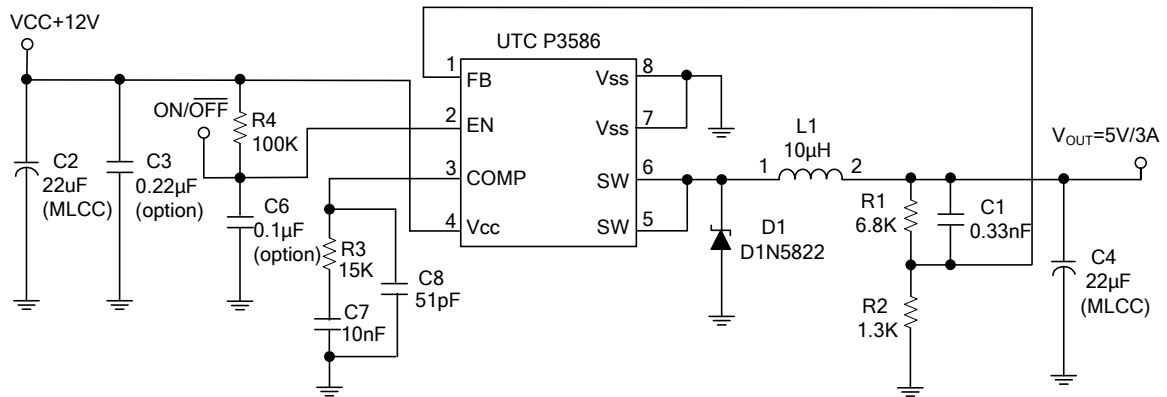

Notes: $V_{OUT} = V_{FB} \times \left(\frac{R1 + R2}{R2} \right)$

(C2 can choose 220µF Low ESR AL Cap Or 22µF MLCC Cap)

■ TYPICAL CHARACTERISTICS

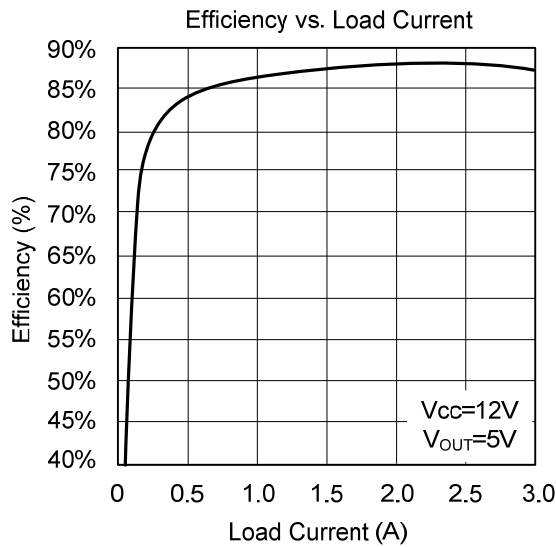
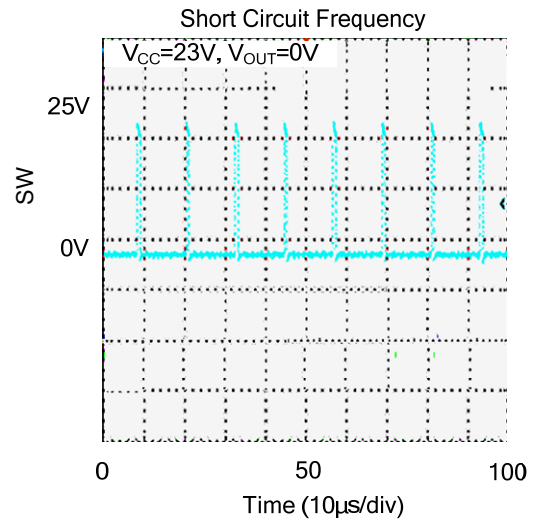
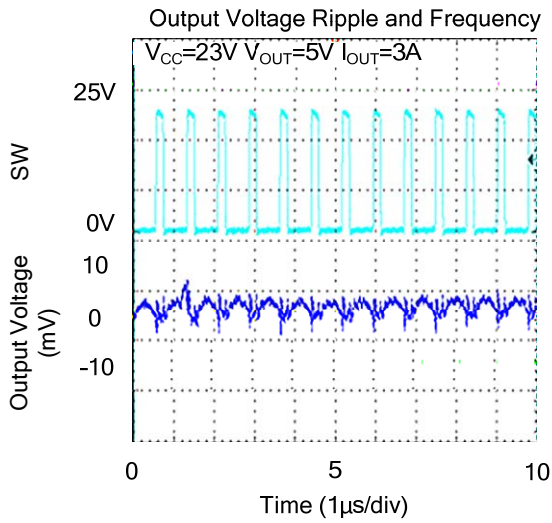

UTC assumes no responsibility for equipment failures that result from using products at values that exceed, even momentarily, rated values (such as maximum ratings, operating condition ranges, or other parameters) listed in products specifications of any and all UTC products described or contained herein. UTC products are not designed for use in life support appliances, devices or systems where malfunction of these products can be reasonably expected to result in personal injury. Reproduction in whole or in part is prohibited without the prior written consent of the copyright owner. The information presented in this document does not form part of any quotation or contract, is believed to be accurate and reliable and may be changed without notice.