

# Trimmer Potentiometers



## SMD Open Type 3mm Size PVZ3/PVS3/PVA3 Series

### PVZ3 Series

#### ■ Features

1. Excellent solderability characteristics are achieved via special plating techniques on each termination.
2. Specially designed substrate prevents wicking of flux onto the top of the part body.
3. Funnel shaped adjustment slot allows for in-process automatic adjustment.
4. High-heat resistance type is available (PVZ3A\_C01/PVZ3K\_E01/PVZ3R\_E01).
5. Enlarged bottom termination enhance soldering strength while reducing the necessary land area required promoting high-density PCB mounting.
6. Flat surface is provided for smooth pick and place (PVZ3K only).
7. The standard position of driver plate is adjusted at the center normally, but another position is also available.
8. This product meets Pb-free.

#### ■ Applications

1. Optical pick up
2. Cordless telephones
3. CD players
4. FDD
5. Motor
6. CD-ROMs
7. Car stereos
8. TFT-LCD TV sets
9. Headphone stereos



PVZ3A

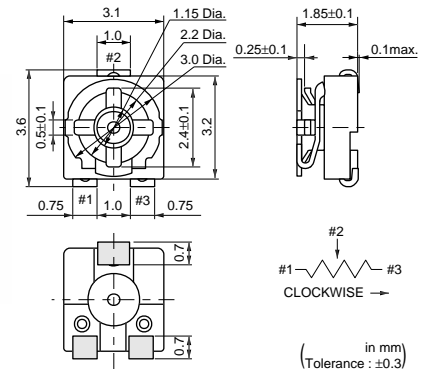

PVZ3K

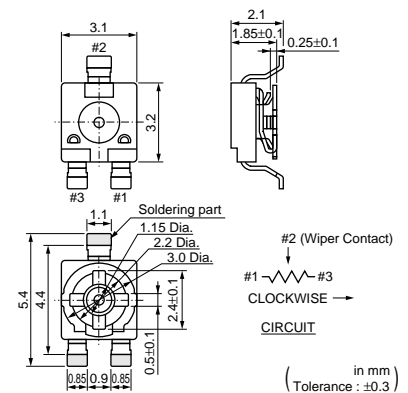

PVZ3R

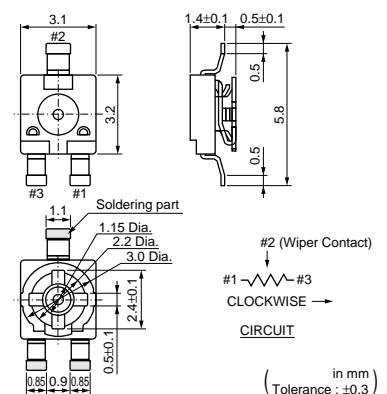

Part Number	Power Rating	Soldering Method	Number of Turns (Effective Rotation Angle)	Total Resistance Value	TCR
PVZ3A201□	0.1W(50°C)	Reflow/Soldering Iron	1(230°±10°)	200ohm ±30%	±500ppm/°C
PVZ3A301□	0.1W(50°C)	Reflow/Soldering Iron	1(230°±10°)	300ohm ±30%	±500ppm/°C
PVZ3A501□	0.1W(50°C)	Reflow/Soldering Iron	1(230°±10°)	500ohm ±30%	±500ppm/°C
PVZ3A102□	0.1W(50°C)	Reflow/Soldering Iron	1(230°±10°)	1k ohm ±30%	±500ppm/°C
PVZ3A202□	0.1W(50°C)	Reflow/Soldering Iron	1(230°±10°)	2k ohm ±30%	±500ppm/°C
PVZ3A302□	0.1W(50°C)	Reflow/Soldering Iron	1(230°±10°)	3k ohm ±30%	±500ppm/°C
PVZ3A502□	0.1W(50°C)	Reflow/Soldering Iron	1(230°±10°)	5k ohm ±30%	±500ppm/°C
PVZ3A103□	0.1W(50°C)	Reflow/Soldering Iron	1(230°±10°)	10k ohm ±30%	±500ppm/°C
PVZ3A203□	0.1W(50°C)	Reflow/Soldering Iron	1(230°±10°)	20k ohm ±30%	±500ppm/°C
PVZ3A303□	0.1W(50°C)	Reflow/Soldering Iron	1(230°±10°)	30k ohm ±30%	±500ppm/°C

Continued on the following page.

Continued from the preceding page.

Part Number	Power Rating	Soldering Method	Number of Turns (Effective Rotation Angle)	Total Resistance Value	TCR
PVZ3A503□	0.1W(50°C)	Reflow/Soldering Iron	1(230°±10°)	50k ohm ±30%	±500ppm/°C
PVZ3A104□	0.1W(50°C)	Reflow/Soldering Iron	1(230°±10°)	100k ohm ±30%	±500ppm/°C
PVZ3A204□	0.1W(50°C)	Reflow/Soldering Iron	1(230°±10°)	200k ohm ±30%	±500ppm/°C
PVZ3A304□	0.1W(50°C)	Reflow/Soldering Iron	1(230°±10°)	300k ohm ±30%	±500ppm/°C
PVZ3A504□	0.1W(50°C)	Reflow/Soldering Iron	1(230°±10°)	500k ohm ±30%	±500ppm/°C
PVZ3A105□	0.1W(50°C)	Reflow/Soldering Iron	1(230°±10°)	1M ohm ±30%	±500ppm/°C
PVZ3A205□	0.1W(50°C)	Reflow/Soldering Iron	1(230°±10°)	2M ohm ±30%	±500ppm/°C
PVZ3K201E01	0.1W(50°C)	Reflow/Soldering Iron	1(230°±10°)	200ohm ±30%	±500ppm/°C
PVZ3K301E01	0.1W(50°C)	Reflow/Soldering Iron	1(230°±10°)	300ohm ±30%	±500ppm/°C
PVZ3K501E01	0.1W(50°C)	Reflow/Soldering Iron	1(230°±10°)	500ohm ±30%	±500ppm/°C
PVZ3K102E01	0.1W(50°C)	Reflow/Soldering Iron	1(230°±10°)	1k ohm ±30%	±500ppm/°C
PVZ3K202E01	0.1W(50°C)	Reflow/Soldering Iron	1(230°±10°)	2k ohm ±30%	±500ppm/°C
PVZ3K302E01	0.1W(50°C)	Reflow/Soldering Iron	1(230°±10°)	3k ohm ±30%	±500ppm/°C
PVZ3K502E01	0.1W(50°C)	Reflow/Soldering Iron	1(230°±10°)	5k ohm ±30%	±500ppm/°C
PVZ3K103E01	0.1W(50°C)	Reflow/Soldering Iron	1(230°±10°)	10k ohm ±30%	±500ppm/°C
PVZ3K203E01	0.1W(50°C)	Reflow/Soldering Iron	1(230°±10°)	20k ohm ±30%	±500ppm/°C
PVZ3K303E01	0.1W(50°C)	Reflow/Soldering Iron	1(230°±10°)	30k ohm ±30%	±500ppm/°C
PVZ3K503E01	0.1W(50°C)	Reflow/Soldering Iron	1(230°±10°)	50k ohm ±30%	±500ppm/°C
PVZ3K104E01	0.1W(50°C)	Reflow/Soldering Iron	1(230°±10°)	100k ohm ±30%	±500ppm/°C
PVZ3K204E01	0.1W(50°C)	Reflow/Soldering Iron	1(230°±10°)	200k ohm ±30%	±500ppm/°C
PVZ3K304E01	0.1W(50°C)	Reflow/Soldering Iron	1(230°±10°)	300k ohm ±30%	±500ppm/°C
PVZ3K504E01	0.1W(50°C)	Reflow/Soldering Iron	1(230°±10°)	500k ohm ±30%	±500ppm/°C
PVZ3K105E01	0.1W(50°C)	Reflow/Soldering Iron	1(230°±10°)	1M ohm ±30%	±500ppm/°C
PVZ3K205E01	0.1W(50°C)	Reflow/Soldering Iron	1(230°±10°)	2M ohm ±30%	±500ppm/°C
PVZ3R201E01	0.1W(50°C)	Reflow/Soldering Iron	1(230°±10°)	200ohm ±30%	±500ppm/°C
PVZ3R301E01	0.1W(50°C)	Reflow/Soldering Iron	1(230°±10°)	300ohm ±30%	±500ppm/°C
PVZ3R501E01	0.1W(50°C)	Reflow/Soldering Iron	1(230°±10°)	500ohm ±30%	±500ppm/°C
PVZ3R102E01	0.1W(50°C)	Reflow/Soldering Iron	1(230°±10°)	1k ohm ±30%	±500ppm/°C
PVZ3R202E01	0.1W(50°C)	Reflow/Soldering Iron	1(230°±10°)	2k ohm ±30%	±500ppm/°C
PVZ3R302E01	0.1W(50°C)	Reflow/Soldering Iron	1(230°±10°)	3k ohm ±30%	±500ppm/°C
PVZ3R502E01	0.1W(50°C)	Reflow/Soldering Iron	1(230°±10°)	5k ohm ±30%	±500ppm/°C
PVZ3R103E01	0.1W(50°C)	Reflow/Soldering Iron	1(230°±10°)	10k ohm ±30%	±500ppm/°C
PVZ3R203E01	0.1W(50°C)	Reflow/Soldering Iron	1(230°±10°)	20k ohm ±30%	±500ppm/°C
PVZ3R303E01	0.1W(50°C)	Reflow/Soldering Iron	1(230°±10°)	30k ohm ±30%	±500ppm/°C
PVZ3R503E01	0.1W(50°C)	Reflow/Soldering Iron	1(230°±10°)	50k ohm ±30%	±500ppm/°C
PVZ3R104E01	0.1W(50°C)	Reflow/Soldering Iron	1(230°±10°)	100k ohm ±30%	±500ppm/°C
PVZ3R204E01	0.1W(50°C)	Reflow/Soldering Iron	1(230°±10°)	200k ohm ±30%	±500ppm/°C
PVZ3R304E01	0.1W(50°C)	Reflow/Soldering Iron	1(230°±10°)	300k ohm ±30%	±500ppm/°C
PVZ3R504E01	0.1W(50°C)	Reflow/Soldering Iron	1(230°±10°)	500k ohm ±30%	±500ppm/°C
PVZ3R105E01	0.1W(50°C)	Reflow/Soldering Iron	1(230°±10°)	1M ohm ±30%	±500ppm/°C
PVZ3R205E01	0.1W(50°C)	Reflow/Soldering Iron	1(230°±10°)	2M ohm ±30%	±500ppm/°C

The blank column is filled with the code of individual specification A01 (standard type) and C01 (high-heat resistance type).

■ Construction

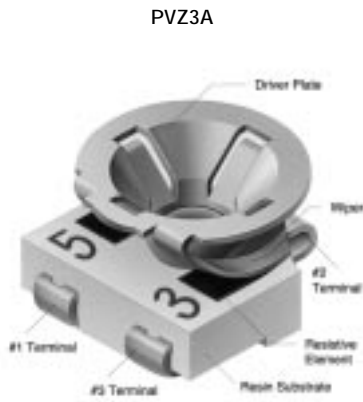

■ Standard Land Pattern

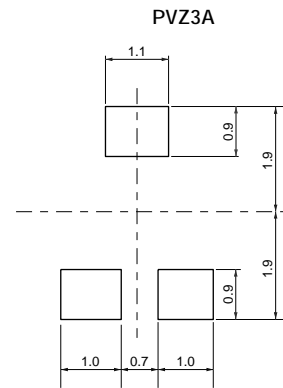

(in mm)  
(Tolerance : ±0.1)

■ Construction

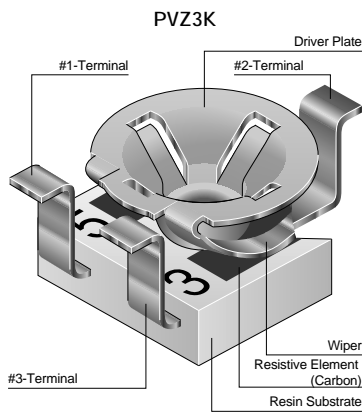

■ Standard Land Pattern

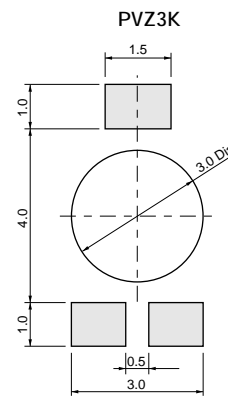

(in mm)  
(Tolerance : ±0.1)

■ Construction

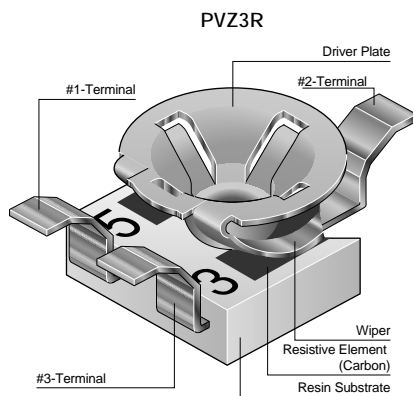

■ Standard Land Pattern

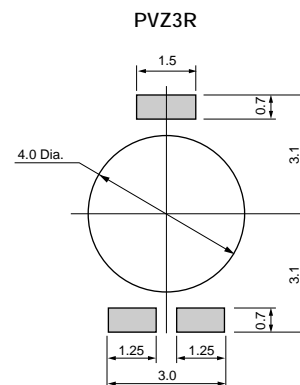

(in mm)  
(Tolerance : ±0.1)

■ Characteristics

Humidity Exposure	Res. Change : +10, -2%
High Temperature Exposure	Res. Change : $R \leq 100\text{kohm} \dots +2, -10\%$ $100\text{kohm} < R \dots +2, -15\%$
Humidity Load Life	Res. Change : ±10%
Load Life	Res. Change : $R \leq 100\text{kohm} \dots +2, -10\%$ $100\text{kohm} < R \dots +2, -15\%$
Temperature Cycle	Res. Change : ±5%
Temperature Coefficient of Resistance	±500ppm/°C
Rotational Life	Res. Change : ±10% (10 cycles)

## PVS3 Series

### ■ Features

1. Funnel shaped slot allows for in-process automatic adjustment and it provides superior adjustability.
2. Easy insertion and operation of adjustment screwdriver
3. Low profile of 1.5mm height with stopper
4. Plated termination achieves high resistance to solder leaching.
5. Screwdrivers for adjustment are available on the market.

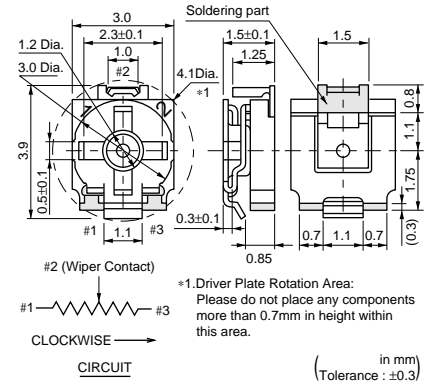

### ■ Applications

1. Camcorders
2. Video disk players
3. TFT-LCD TV sets
4. Headphone stereos
5. Cordless telephones
6. Micro-motors
7. Optical cameras

Part Number	Power Rating	Soldering Method	Number of Turns (Effective Rotation Angle)	Total Resistance Value	TCR
PVS3A101A01	0.1W(70°C)	Reflow/Soldering Iron	1(270°±10°)	100ohm ±25%	±250ppm/°C
PVS3A201A01	0.1W(70°C)	Reflow/Soldering Iron	1(270°±10°)	200ohm ±25%	±250ppm/°C
PVS3A301A01	0.1W(70°C)	Reflow/Soldering Iron	1(270°±10°)	300ohm ±25%	±250ppm/°C
PVS3A501A01	0.1W(70°C)	Reflow/Soldering Iron	1(270°±10°)	500ohm ±25%	±250ppm/°C
PVS3A102A01	0.1W(70°C)	Reflow/Soldering Iron	1(270°±10°)	1k ohm ±25%	±250ppm/°C
PVS3A202A01	0.1W(70°C)	Reflow/Soldering Iron	1(270°±10°)	2k ohm ±25%	±250ppm/°C
PVS3A302A01	0.1W(70°C)	Reflow/Soldering Iron	1(270°±10°)	3k ohm ±25%	±250ppm/°C
PVS3A502A01	0.1W(70°C)	Reflow/Soldering Iron	1(270°±10°)	5k ohm ±25%	±250ppm/°C
PVS3A103A01	0.1W(70°C)	Reflow/Soldering Iron	1(270°±10°)	10k ohm ±25%	±250ppm/°C
PVS3A203A01	0.1W(70°C)	Reflow/Soldering Iron	1(270°±10°)	20k ohm ±25%	±250ppm/°C
PVS3A303A01	0.1W(70°C)	Reflow/Soldering Iron	1(270°±10°)	30k ohm ±25%	±250ppm/°C
PVS3A503A01	0.1W(70°C)	Reflow/Soldering Iron	1(270°±10°)	50k ohm ±25%	±250ppm/°C
PVS3A104A01	0.1W(70°C)	Reflow/Soldering Iron	1(270°±10°)	100k ohm ±25%	±250ppm/°C
PVS3A204A01	0.1W(70°C)	Reflow/Soldering Iron	1(270°±10°)	200k ohm ±25%	±250ppm/°C
PVS3A304A01	0.1W(70°C)	Reflow/Soldering Iron	1(270°±10°)	300k ohm ±25%	±250ppm/°C
PVS3A504A01	0.1W(70°C)	Reflow/Soldering Iron	1(270°±10°)	500k ohm ±25%	±250ppm/°C
PVS3A105A01	0.1W(70°C)	Reflow/Soldering Iron	1(270°±10°)	1M ohm ±25%	±250ppm/°C
PVS3A205A01	0.1W(70°C)	Reflow/Soldering Iron	1(270°±10°)	2M ohm ±25%	±250ppm/°C

### ■ Construction

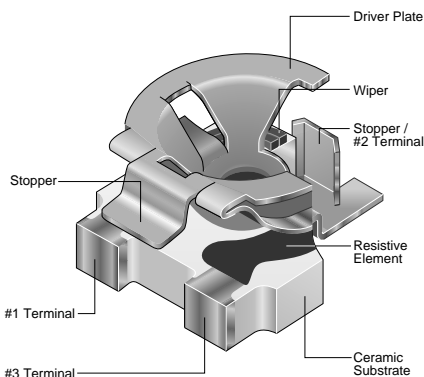

### ■ Standard Land Pattern

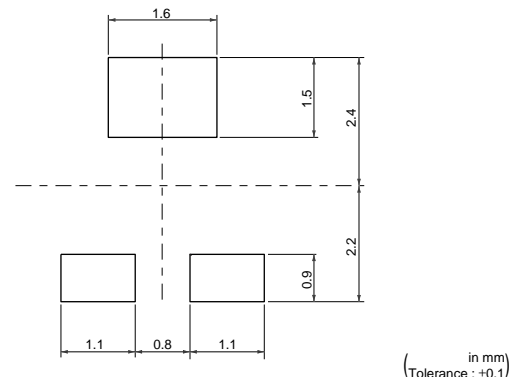

Continued on the following page. ↗

↳ Continued from the preceding page.

### ■ Characteristics

Humidity Exposure	Res. Change : $\pm 3\%$
High Temperature Exposure	Res. Change : $\pm 3\%$
Humidity Load Life	Res. Change : $\pm 3\%$
Load Life	Res. Change : $\pm 3\%$
Temperature Cycle	Res. Change : $\pm 3\%$
Temperature Coefficient of Resistance	$\pm 250\text{ppm}/^\circ\text{C}$
Rotational Life	Res. Change : $\pm 10\%$ (10 cycles)

## PVA3 Series

### ■ Features

1. Funnel shaped slot allows for in-process automatic adjustment and it provides superior adjustability.
2. Easy insertion and operation of adjustment screwdriver
3. Plated termination achieves high resistance to solder leaching.
4. Screwdrivers for adjustment are available on the market.
5. Recommended for both reflow and flow soldering method. (Need cleaning for flow soldering method)

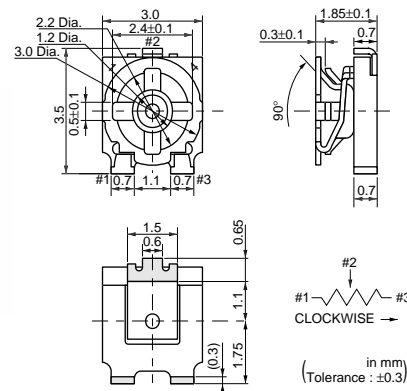

### ■ Applications

1. Camcorders
2. Video disk players
3. TFT-LCD TV sets
4. Headphone stereos
5. Cordless telephones
6. Micro-motors
7. Optical cameras

Part Number	Power Rating	Soldering Method	Number of Turns (Effective Rotation Angle)	Total Resistance Value	TCR
PVA3A101A01	0.1W(70°C)	Flow/Reflow/Soldering Iron	1(270°±10°)	100ohm ±25%	±250ppm/°C
PVA3A201A01	0.1W(70°C)	Flow/Reflow/Soldering Iron	1(270°±10°)	200ohm ±25%	±250ppm/°C
PVA3A301A01	0.1W(70°C)	Flow/Reflow/Soldering Iron	1(270°±10°)	300ohm ±25%	±250ppm/°C
PVA3A501A01	0.1W(70°C)	Flow/Reflow/Soldering Iron	1(270°±10°)	500ohm ±25%	±250ppm/°C
PVA3A102A01	0.1W(70°C)	Flow/Reflow/Soldering Iron	1(270°±10°)	1k ohm ±25%	±250ppm/°C
PVA3A202A01	0.1W(70°C)	Flow/Reflow/Soldering Iron	1(270°±10°)	2k ohm ±25%	±250ppm/°C
PVA3A302A01	0.1W(70°C)	Flow/Reflow/Soldering Iron	1(270°±10°)	3k ohm ±25%	±250ppm/°C
PVA3A502A01	0.1W(70°C)	Flow/Reflow/Soldering Iron	1(270°±10°)	5k ohm ±25%	±250ppm/°C
PVA3A103A01	0.1W(70°C)	Flow/Reflow/Soldering Iron	1(270°±10°)	10k ohm ±25%	±250ppm/°C
PVA3A203A01	0.1W(70°C)	Flow/Reflow/Soldering Iron	1(270°±10°)	20k ohm ±25%	±250ppm/°C
PVA3A303A01	0.1W(70°C)	Flow/Reflow/Soldering Iron	1(270°±10°)	30k ohm ±25%	±250ppm/°C
PVA3A503A01	0.1W(70°C)	Flow/Reflow/Soldering Iron	1(270°±10°)	50k ohm ±25%	±250ppm/°C
PVA3A104A01	0.1W(70°C)	Flow/Reflow/Soldering Iron	1(270°±10°)	100k ohm ±25%	±250ppm/°C
PVA3A204A01	0.1W(70°C)	Flow/Reflow/Soldering Iron	1(270°±10°)	200k ohm ±25%	±250ppm/°C
PVA3A304A01	0.1W(70°C)	Flow/Reflow/Soldering Iron	1(270°±10°)	300k ohm ±25%	±250ppm/°C
PVA3A504A01	0.1W(70°C)	Flow/Reflow/Soldering Iron	1(270°±10°)	500k ohm ±25%	±250ppm/°C
PVA3A105A01	0.1W(70°C)	Flow/Reflow/Soldering Iron	1(270°±10°)	1M ohm ±25%	±250ppm/°C
PVA3A205A01	0.1W(70°C)	Flow/Reflow/Soldering Iron	1(270°±10°)	2M ohm ±25%	±250ppm/°C

### ■ Construction

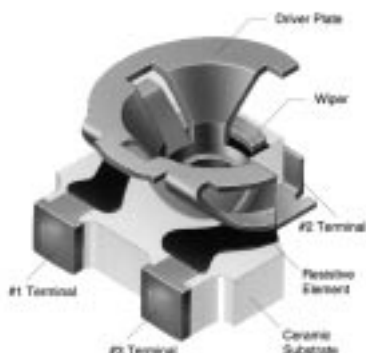

### ■ Standard Land Pattern

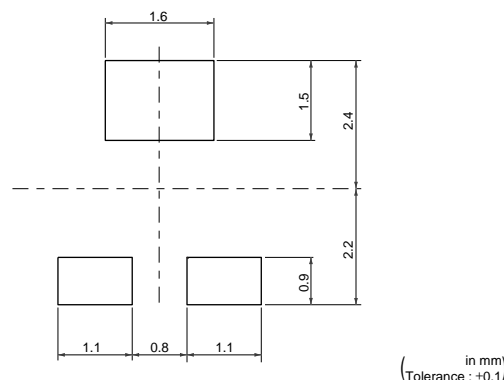

Continued on the following page.

↳ Continued from the preceding page.

### ■ Characteristics

Humidity Exposure	Res. Change : $\pm 3\%$
High Temperature Exposure	Res. Change : $\pm 3\%$
Humidity Load Life	Res. Change : $\pm 3\%$
Load Life	Res. Change : $\pm 3\%$
Temperature Cycle	Res. Change : $\pm 3\%$
Temperature Coefficient of Resistance	$\pm 250\text{ppm}/^\circ\text{C}$
Rotational Life	Res. Change : $\pm 10\%$ (10 cycles)

## PVZ3/PVS3/PVA3 Series Notice

2

### ■ Notice (Operating and Storage Conditions)

1. Store in temperatures of -10 to +40 deg. C and relative humidity of 30-85%RH.
2. Do not store in or near corrosive gases.
3. Use within six months after delivery.
4. Open the package just before using.
5. Do not store under direct sunlight.
6. If you use the trimmer potentiometer in an environment other than listed below, please consult with a Murata factory representative prior to using.  
The trimmer potentiometer should not be used under

- the following environmental conditions:
- (1) Corrosive gaseous atmosphere  
(Ex. Chlorine gas, Hydrogen sulfide gas, Ammonia gas, Sulfuric acid gas, Nitric oxide gas, etc.)
  - (2) In liquid  
(Ex. Oil, Medical liquid, Organic solvent, etc.)
  - (3) Dusty / dirty atmosphere
  - (4) Direct sunlight
  - (5) Static voltage nor electric/magnetic fields
  - (6) Direct sea breeze
  - (7) Other variations of the above

### ■ Notice (Rating)

1. When using with partial load (rheostat), minimize the power depending on the resistance value.
2. The maximum input voltage to a trimmer potentiometer should not exceed  $(P.R)^{1/2}$  or the maximum operating voltage, whichever is smaller.
3. The maximum input current to a trimmer potentiometer should not exceed  $(P/R)^{1/2}$  or the allowable wiper current, whichever is smaller.
4. If the trimmer potentiometer is used in DC and high humidity conditions, please connect wiper (#2) for plus and resistive element (#1 or #3) for minus.  
(PVZ3 Series only)

### ■ Notice (Soldering and Mounting)

1. Soldering
  - (1) Standard soldering condition
    - (a) Reflow soldering :  
Refer to the standard temperature profile.
    - (b) Soldering iron:  
\*PVZ3A\_A01 series  
>Temperature of tip 260 deg. C max.  
>Soldering time 3 sec. max.  
>Diameter 2mm max.  
>Wattage of iron 30W max.  
\*PVZ3A\_C01, PVZ3K\_E01, PVZ3R\_E01 series  
\*PVS3, PVA3 series  
>Temperature of tip 360 deg. C max.  
>Soldering time 3 sec. max.  
>Diameter 2mm max.  
>Wattage of iron 30W max.Before using other soldering conditions than those listed above, please consult with Murata factory representative prior to using. If the soldering conditions are not suitable, e.g., excessive time and/or excessive temperature, the trimmer potentiometer may deviate from the specified characteristics.
  - (2) Flow soldering is available for PVA3 series.  
For PVZ3 and PVS3, do not use flow soldering method (dipping).

- If you use the flow soldering method, the trimmer potentiometer may not function.
- (3) The soldering iron should not come in contact with the case of the trimmer potentiometer. If such contact does occur, the trimmer potentiometer may be damaged.
  - (4) Apply the appropriate amount of solder paste.  
The thickness of solder paste should be printed from 150 micro m to 200 micro m (PVZ3 series should be printed from 100 micro m to 150 micro m) and the dimension of land pattern used should be Murata's standard land pattern at reflow soldering. Insufficient amounts of solder can lead to insufficient soldering strength on PCB. Excessive amounts of solder may cause bridging between the terminals.
2. Mounting
    - (1) Use our standard land dimension. Excessive land area causes displacement due to the effect of the surface tension of the solder. Insufficient land area leads to insufficient soldering strength of the chip.
    - (2) Do not apply excessive force (preferably 4.9N (Ref.; 500gf) max.), when the trimmer potentiometer is mounted to the PCB.
    - (3) Do not warp and/or bend PC board to prevent

Continued on the following page. 



## PVZ3/PVS3/PVA3 Series Notice

Continued from the preceding page.

trimmer potentiometer from breakage.

- (4) In chip placers, the recommended size of the cylindrical pick-up nozzle should be outer dimension 2.5-2.8mm dia. and inner dimension 2mm dia.

### 3. Cleaning

- (1) In case there is flux on the resistive element,

clean sufficiently with cleaning solvents and completely remove all residual flux.

- (2) Isopropyl-alcohol and Ethyl-alcohol are applicable solvents for cleaning. If you use any other types of solvents, please evaluate performance by your product.

2

### Flow Soldering Standard Profile

PVA3 Series Only

For flow soldering

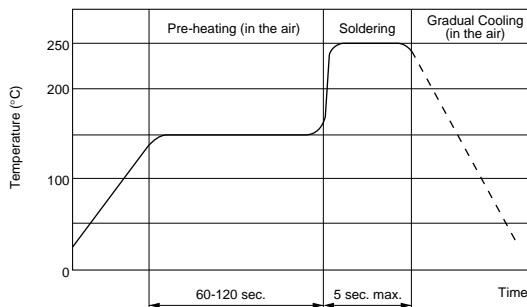

### Reflow Soldering Standard Profile

PVA3/PVS3/PVZ3\_A01 Series

For reflow soldering

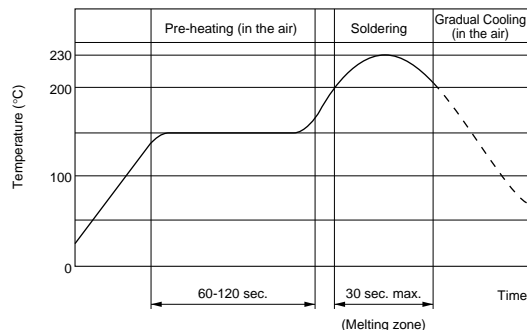

PVZ3\_C01/E01 Series

For reflow soldering

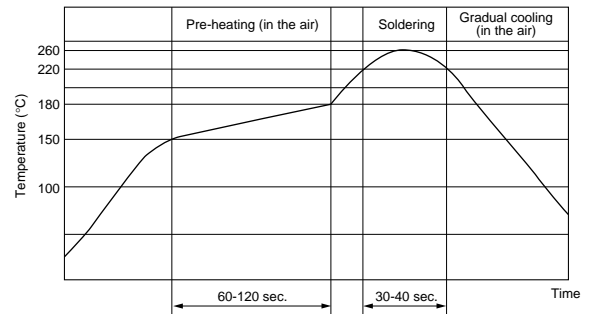

### Notice (Handling)

- Use suitable screwdrivers that fit comfortably in driver slot. We recommend the screwdrivers below.
  - \* Recommended screwdriver for manual adjustment <PVZ3/PVA3 series>  
VESSEL MFG. : NO.9000+1.7x30  
(Murata P/N : KMDR080)
  - <PVZ3/PVA3/PVS3 series>  
TORAY MFG. : SA-2225  
(Murata P/N : KMDR070)
  - \* Recommended screwdriver for automatic adjustment  
TORAY MFG. : JB-2225  
(Murata P/N : KMBT070)
- Don't apply more than 4.9N (Ref.; 500gf) of twist

and stress after mounting onto PCB to prevent contact intermittence. If excessive force is applied, the trimmer potentiometer may not function.

- For PVZ3 and PVA3 series, please use within the effective rotational angle.  
The potentiometer does not have a mechanical stop for over rotation. In cases out of effective rotational angle, the trimmer potentiometer may not function.
- When using a lock paint to fix slot position, please consult with a Murata factory representative prior to using to prevent corrosion and contact intermittence.

## PVZ3/PVS3/PVA3 Series Notice

### ■ Notice (Other)

1. Please make sure that your product has been evaluated and confirmed against your specifications when our product is mounted to your product.
2. Murata cannot guarantee trimmer potentiometer integrity when used under conditions other than those specified in this document.

2

## SMD Open Type and SMD Sealed Type PVM4A\_C01 Series Specifications and Test Methods

The tests and measurements should be conducted under the condition of 15 to 35°C of temperature, 25 to 75% of relative humidity and 86 to 106 kpa of atmospheric pressure unless otherwise specified. If questionable results occur that have been measured in accordance with the above mentioned conditions, the tests and measurements should be conducted under the condition of 25±2°C of temperature and, 45 to 55% of relative humidity and 86 to 106 kpa of atmospheric pressure.

No.	Item	Test Methods																														
1	Total Resistance	<p>Measure total resistance between the resistance element and terminals (terminals #1 and #3) with the contact arm positioned against a stop. The positioning of the contact arm and terminal should be the same for subsequent total resistance measurements on the same device.</p> <p>Use the test voltage specified in Table-1 for total resistance measurements. This voltage should be used whenever a subsequent total resistance measurement is made.</p> <table border="1" style="margin-left: auto; margin-right: auto;"> <thead> <tr> <th>Total Resistance, Nominal (ohm)</th> <th>Maximum Test Voltage (V)</th> </tr> </thead> <tbody> <tr> <td>10≤R≤100</td> <td>1.0</td> </tr> <tr> <td>100&lt;R≤1k</td> <td>3.0</td> </tr> <tr> <td>1k&lt;R≤10k</td> <td>10.0</td> </tr> <tr> <td>10k&lt;R≤100k</td> <td>30.0</td> </tr> <tr> <td>100k&lt;R</td> <td>100.0</td> </tr> </tbody> </table> <p style="text-align: center;">Table 1: Total resistance test voltage</p>	Total Resistance, Nominal (ohm)	Maximum Test Voltage (V)	10≤R≤100	1.0	100<R≤1k	3.0	1k<R≤10k	10.0	10k<R≤100k	30.0	100k<R	100.0																		
Total Resistance, Nominal (ohm)	Maximum Test Voltage (V)																															
10≤R≤100	1.0																															
100<R≤1k	3.0																															
1k<R≤10k	10.0																															
10k<R≤100k	30.0																															
100k<R	100.0																															
2	Residual Resistance	<p>Position the contact arm at the extreme counterclockwise limit of mechanical travel and measure the resistance between the contact arm and the corresponding end terminal. Then, position the contact arm at the extreme clockwise limit of mechanical travel and measure the resistance between the contact arm and the corresponding end terminal. During this test, take suitable precautions to ensure that the rated current of the resistance element is not exceeded.</p>																														
3	Contact Resistance	<p>Contact resistance variation should be measured with the measuring circuit shown below, or its equivalent. The operating wiper should be rotated in both directions through 90% of the actual effective-electrical travel for a total of 6 cycles.</p> <p>The rate of rotation of the operating wiper should be such that the wiper completes 1 count in determining whether or not a contact resistance variation is observed at least twice in the same location. The test current should follow the value given in Table-2 unless otherwise limited by the power rating.</p> <table border="1" style="margin-left: auto; margin-right: auto;"> <thead> <tr> <th>Standard Total Resistance R (ohm)</th> <th>Test Current</th> </tr> </thead> <tbody> <tr> <td>100≤R&lt;10k</td> <td>10mA max.</td> </tr> <tr> <td>10k≤R&lt;100k</td> <td>1mA max.</td> </tr> <tr> <td>100k≤R</td> <td>100μA max.</td> </tr> </tbody> </table> <p style="text-align: center;">Table 2: Test current for CRV</p> <div style="text-align: center;"> <p style="font-size: small;">Rx : Trimmer Potentiometer Oscilloscope bandwidth :100Hz to 50KHz</p> <p>Figure 1: CRV measuring circuit</p> </div>	Standard Total Resistance R (ohm)	Test Current	100≤R<10k	10mA max.	10k≤R<100k	1mA max.	100k≤R	100μA max.																						
Standard Total Resistance R (ohm)	Test Current																															
100≤R<10k	10mA max.																															
10k≤R<100k	1mA max.																															
100k≤R	100μA max.																															
4	Humidity Exposure	<p>The wiper contact point should be preset at about 50% position of effective rotational angle. After that, the potentiometer should be placed in a chamber at 40±2°C and 90 - 95% without loading for 500±12 hours. The resistance value should be measured after keeping the potentiometer in a room for 5±1/6 hours.</p>																														
5	High Temperature Exposure	<p>The wiper contact point should be preset at about 50% position of effective rotational angle. After that, the potentiometer should be placed in a chamber at 70±2°C without loading for 500±12 hours. The resistance value should be measured after keeping the potentiometer in a room for 1.5±1/6 hours.</p>																														
6	Humidity Load Life	<p>The wiper contact point should be preset at about 50% position of effective rotational angle. After that, the potentiometer should be placed in a chamber at 40±2°C and 90 - 95% with loading the 1/2 rated voltage between #1 and #2 terminals, intermittently 1.5 hours ON and 0.5 hours OFF for 1000±12hours. The resistance value should be measured after keeping the potentiometer in a room for 5±1/6 hours.</p>																														
7	Load Life	<p>The wiper contact point should be preset at about 50% position of effective rotational angle. After that, the potentiometer should be placed in a chamber at 70±2°C (50±2°C for PVZ) with loading the 1/2 rated voltage between #1 and #2 terminals, intermittently 1.5 hours ON and 0.5 hours OFF for 1000±12 hours. The resistance value should be measured after keeping the potentiometer in a room for 1.5±1/6 hours.</p>																														
8	Temperature Cycle	<p>The wiper contact point should be preset at about 50% position of effective rotational angle. After that, the potentiometer should be subjected to Table 3, Table 4 temperature for 5 cycles. The resistance value should be measured after keeping the potentiometer in a room for 1.5±10 minutes.</p> <table border="1" style="margin-left: auto; margin-right: auto;"> <thead> <tr> <th>Sequence</th> <th>1</th> <th>2</th> <th>3</th> <th>4</th> </tr> </thead> <tbody> <tr> <td>Temp. (°C)</td> <td>-25±3</td> <td>+25±2</td> <td>+85±3</td> <td>+25±2</td> </tr> <tr> <td>Time (min.)</td> <td>30±3</td> <td>10max.</td> <td>30±3</td> <td>10max.</td> </tr> </tbody> </table> <p style="text-align: center;">Table 3: PVZ</p> <table border="1" style="margin-left: auto; margin-right: auto;"> <thead> <tr> <th>Sequence</th> <th>1</th> <th>2</th> <th>3</th> <th>4</th> </tr> </thead> <tbody> <tr> <td>Temp. (°C)</td> <td>-55±3</td> <td>+25±2</td> <td>+125±3</td> <td>+25±2</td> </tr> <tr> <td>Time (min.)</td> <td>30±3</td> <td>10max.</td> <td>30±3</td> <td>10max.</td> </tr> </tbody> </table> <p style="text-align: center;">Table 4: PVA3/PVS3/PVM4A□□□C01</p>	Sequence	1	2	3	4	Temp. (°C)	-25±3	+25±2	+85±3	+25±2	Time (min.)	30±3	10max.	30±3	10max.	Sequence	1	2	3	4	Temp. (°C)	-55±3	+25±2	+125±3	+25±2	Time (min.)	30±3	10max.	30±3	10max.
Sequence	1	2	3	4																												
Temp. (°C)	-25±3	+25±2	+85±3	+25±2																												
Time (min.)	30±3	10max.	30±3	10max.																												
Sequence	1	2	3	4																												
Temp. (°C)	-55±3	+25±2	+125±3	+25±2																												
Time (min.)	30±3	10max.	30±3	10max.																												

Continued on the following page.

## SMD Open Type and SMD Sealed Type PVM4A\_C01 Series Specifications and Test Methods

Continued from the preceding page.

No.	Item	Test Methods																				
9	Temperature Coefficient of Resistance	<p>The trimmer potentiometer should be subjected to each of the following temperatures (see Table 5, Table 6) for 30 to 45 minutes. The resistance value should be measured in the chamber.</p> $TCR = \frac{R_2 - R_1}{R_1 (T_2 - T_1)} \times 10^6 \text{ (ppm/}^\circ\text{C)}$ <p>                     T<sub>1</sub> : Reference temperature in degrees celsius                      T<sub>2</sub> : Test temperature in degrees celsius                      R<sub>1</sub> : Resistance at reference temperature in ohm                      R<sub>2</sub> : Resistance at test temperature in ohm                 </p> <table border="1" style="display: inline-table; margin-right: 20px;"> <thead> <tr> <th>Sequence</th> <th>1*</th> <th>2</th> <th>3*</th> <th>4</th> </tr> </thead> <tbody> <tr> <td>Temp. (°C)</td> <td>+25±2</td> <td>-25±3</td> <td>+25±2</td> <td>+85±3</td> </tr> </tbody> </table> <p>Note*: Norm temp.</p> <p style="text-align: center;">Table 5: PVZ</p> <table border="1" style="display: inline-table;"> <thead> <tr> <th>Sequence</th> <th>1</th> <th>2</th> <th>3*</th> <th>4</th> </tr> </thead> <tbody> <tr> <td>Temp. (°C)</td> <td>+25±2</td> <td>-55±3</td> <td>+25±2</td> <td>+125±3</td> </tr> </tbody> </table> <p style="text-align: center;">Table 6: PVA3/PVS3/PVM4A□□□C01</p>	Sequence	1*	2	3*	4	Temp. (°C)	+25±2	-25±3	+25±2	+85±3	Sequence	1	2	3*	4	Temp. (°C)	+25±2	-55±3	+25±2	+125±3
Sequence	1*	2	3*	4																		
Temp. (°C)	+25±2	-25±3	+25±2	+85±3																		
Sequence	1	2	3*	4																		
Temp. (°C)	+25±2	-55±3	+25±2	+125±3																		
10	Rotational Life	<p>The wiper should be rotated over 90% of the effective rotational angle without loading at a speed of 10 cycles per minute, for 10 cycles continuously. The resistance value should be measured after keeping the potentiometer in a room for 10±5 minutes.</p>																				