

# MODEL 72

## 3/8" Square

## Single Turn

## Cermet Trimming

## Potentiometer

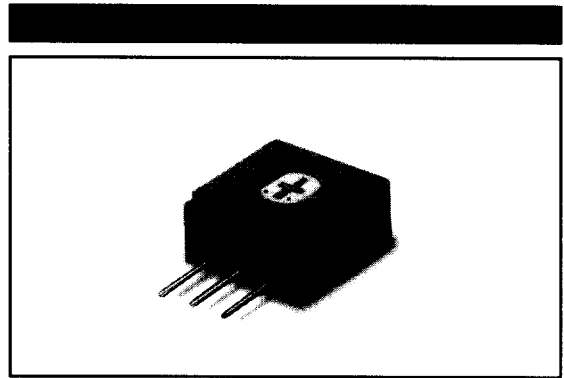

1

### ELECTRICAL

Standard Resistance Range, Ohms	10 to 2Meg
Standard Resistance Tolerance	±10% (<100 Ohms = ±20%)
Input Voltage, Maximum	200 Vdc or rms not to exceed power rating
Slider Current, Maximum	100mA or within rated power, whichever is less
Power Rating, Watts	0.5 at 85°C derating to 0 at 125°C
End Resistance, Maximum	2 Ohms
Actual Electrical Travel, Nominal	244°
Dielectric Strength	900 Vrms
Insulation Resistance, Minimum	1,000 Megohms
Resolution	Essentially infinite
Contact Resistance Variation, Maximum	1% or 1 Ohm, whichever is greater

### ENVIRONMENTAL

Seal	85°C Fluorinert® (No Leaks)
Temperature Coefficient, Maximum	±100ppm/°C
Operating Temperature Range	-55°C to +125°C
Thermal Shock	5 cycles, -55°C to +125°C (1% ΔRT, 1% ΔVR)
Moisture Resistance	Ten 24 hour cycles (1% ΔRT, IR 100 Megohms Min.)
Shock, 6ms Sawtooth	100G's (1% ΔRT, 1% ΔVR)
Vibration	20G's, 10 to 2,000 Hz (1% ΔRT, 1% ΔVR)
High Temperature Exposure	250 hours at 125°C (2% ΔRT, 2% ΔVR)
Rotational Life	200 cycles (3% ΔRT)
Load Life at 0.5 Watts	1,000 hours at 70°C (2% ΔRT)
Resistance to Solder Heat	260°C for 10 sec. (1% ΔRT)

### MECHANICAL

Mechanical Stops	Solid
Torque, Starting Maximum	3 oz.-in. (0.021 N-m)
Weight, Nominal	.025 oz. (0.70 grams)

Fluorinert® is a registered trademark of 3M Company.  
Specifications subject to change without notice.

**TOP ADJUSTMENT (Inch/mm)**

**Model 72P**

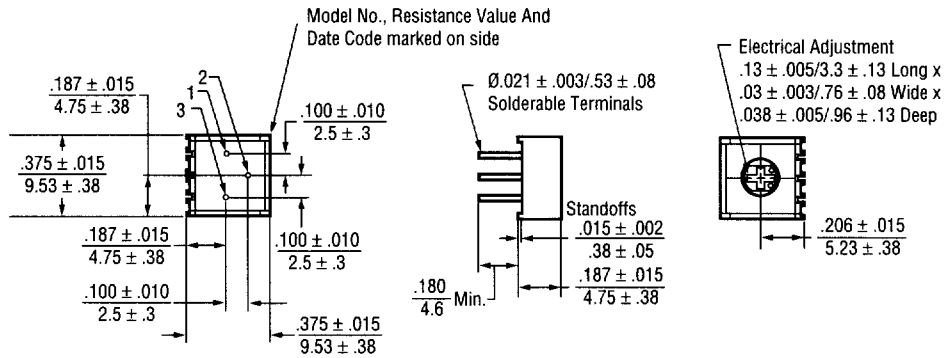

Note: Model 72P dimensions applicable to all other models except as noted.

**Model 72PL**

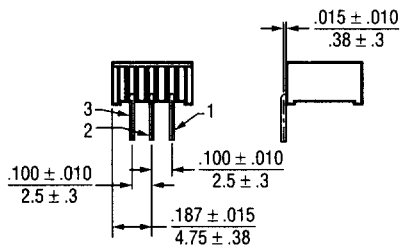

**Model 72PM**

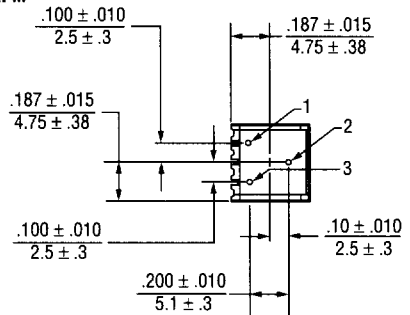

**Model 72PX, 72RPX**

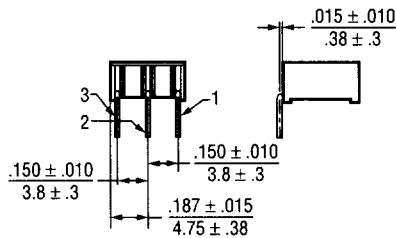

Model 72RPX - Terminals 1 and 3 are reversed

**Model 72RP**

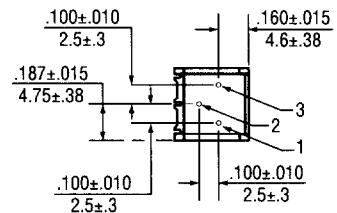

**SIDE ADJUSTMENT (Inch/mm)**

**Model 72X, 72RX**

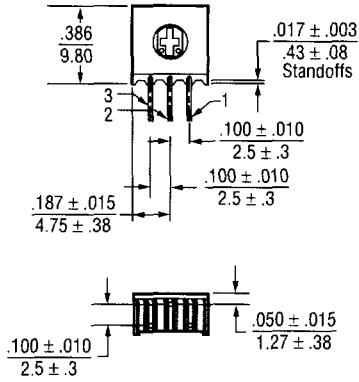

Model 72RX - Terminals 1 and 3 are reversed

**Model 72XL, 72RXL, 72RW**

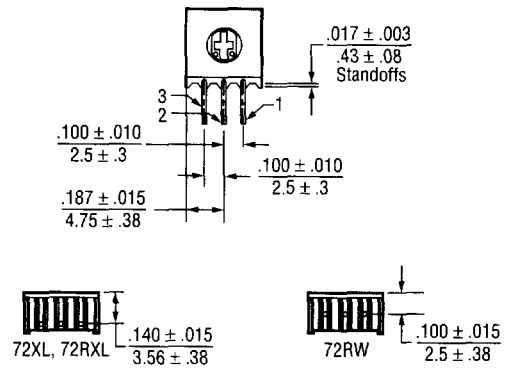

Model 72RXL And 72RW - Terminals 1 and 3 are reversed

**Model 72XW, 72RXW**

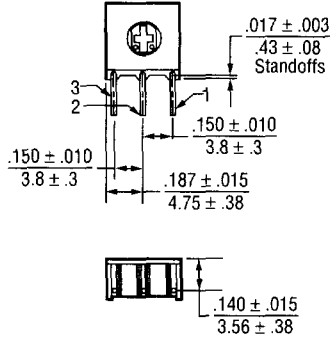

Model 72RXW - Terminals 1 and 3 are reversed

**EXTENDED ROTOR OPTION (Inch/mm)**

Available for all Model 72 pin styles:

72PE, 72PLE, 72PME, 72PXE, 72RPXE, 72XE, 72RXE,  
72XLE, 72RXLE, 72RWE, 72XWE, 72RXWE

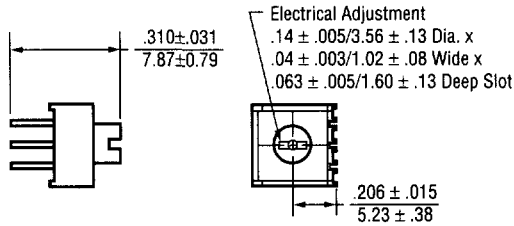

**ADJUSTMENT KNOB OPTION (Inch/mm)**

Available options:

72XT- Side Adjustment (See 72X for Pin Configuration)

72PT- Top Adjustment (See 72P for Pin Configuration)

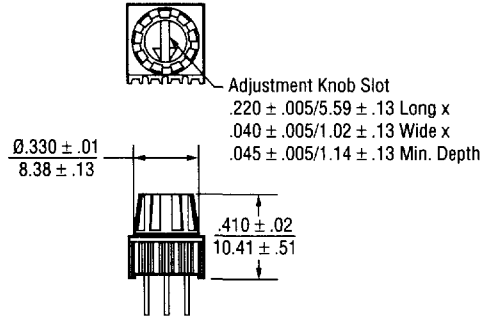

72PT Shown - Dimensions applicable to 72XT

**STANDARD RESISTANCE VALUES, OHMS**

10	100	1K	10K	50K	250K	2Meg
20	200	2K	20K	100K	500K	
50	500	5K	25K	200K	1Meg	

**PACKAGING**

**Standard:** Boxes  
Capacity = 100 Units

**Option:** Tubes  
All units oriented with #1 pin to same side.

	<b>Pin Style</b>	<b>P, PM</b>	<b>X, XL, XW, RW</b>
Magazine	Width	= 0.47"	0.29"
	Height	= 0.54"	0.76"
	Length	= 20.5"	20.1"
	Capacity	= 50 Units	50 Units

**Option:** Tape & Reel, Ammo Pack (Available only for 72RW only)  
All units oriented with #1 pin to the right of the direction of feed.

	Seat Plane to Centerline of Sprocket Hole	= .71" (18.03 mm)	
Tape	Width	= 18 mm	
	Sprocket	= Single Hole .50" spacing	
	Capacity	= 1,000 Units	
Reel	Diameter	= 14" (356mm)	
Ammo	Tape Fold	= 12" (305mm)	
	Box	= 1.8" x 13" x 10" (46mm x 330mm x 254mm)	

## ORDERING INFORMATION

### Standard:

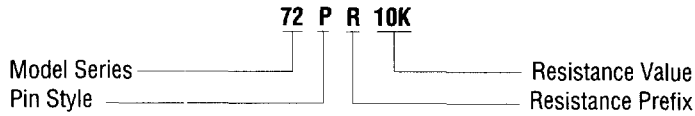

### Option:

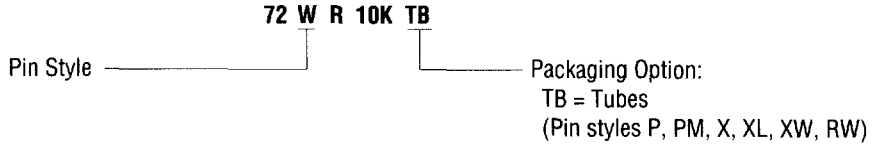

### Option:

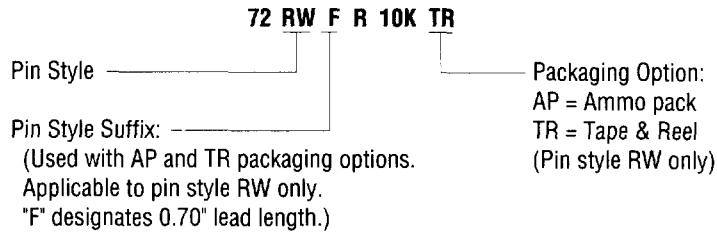

### Option:

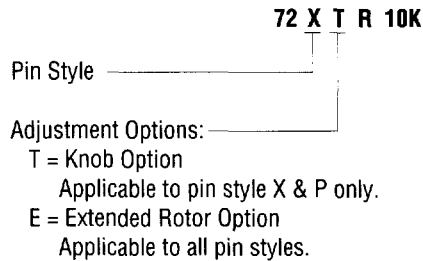

## CIRCUIT DIAGRAM

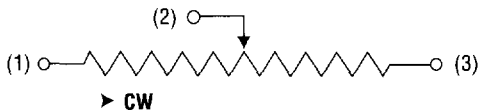

## NOTES

Metric equivalents, based on 1 inch = 25.4mm are rounded to the same number of significant figures as in the original English units and are provided for general information only.

Tolerances unless otherwise specified:  
Linear = ± .01 inches (.25mm)  
Angular = ± 2 degrees

