

DATA SHEET

PCF26100 Bluetooth Adapter IC

Preliminary specification
File under Integrated Circuits, IC17

2001 Jun 19

Bluetooth Adapter IC**PCF26100****CONTENTS**

1	FEATURES
2	GENERAL DESCRIPTION
3	ORDERING INFORMATION
4	BLOCK DIAGRAM
5	PINNING INFORMATION
5.1	Pinning
5.2	Pin description
6	FUNCTIONAL DESCRIPTION
6.1	PCF26100 overview
6.2	BlueRF pin mapping
6.3	Timing
6.4	Serial interface
6.5	Registers
7	REFERENCE DOCUMENTS
8	LIMITING VALUES
9	DC CHARACTERISTICS
10	AC CHARACTERISTICS
11	APPLICATIONS
12	PACKAGE OUTLINE
13	SOLDERING
13.1	Introduction to soldering surface mount packages
13.2	Reflow soldering
13.3	Wave soldering
13.4	Manual soldering
13.5	Suitability of surface mount IC packages for wave and reflow soldering methods
14	DATA SHEET STATUS
15	DEFINITIONS
16	DISCLAIMERS

Bluetooth Adapter IC

PCF26100

1 FEATURES

The PCF26100 performs the following functions:

- Power-on reset (reset)
- System clock generation for baseband controller
- Reference clock generation for the UAA3558
- Low-power clock generation for baseband controller
- Transmit clock generation for baseband controller (1 MHz)
- Serial interface conversion between JTAG and 3-wire S-bus
- Timing control generation for the UAA3558
- Transmit data conversion from digital-to-analog gaussian shaped
- RSSI conversion from analog-to-digital and access through serial JTAG interface
- Transmit PA control information from JTAG interface digital-to-analog conversion

- Provides radio ID through the serial JTAG interface
- System clock oscillator trimming.

2 GENERAL DESCRIPTION

The PCF26100 is a mixed signal based adapter device for wireless Bluetooth systems. The device adapts the baseband interface of the Philips UAA3558 radio to the Philips PCF26002 and PCF26003 baseband controller devices and also to the BlueRF JTAG Unidirectional RxMode 2.

The adapter is provided as a low risk solution to a working Bluetooth system based on existing components. The adapter ASIC implementation incorporates, as much as possible, features to come to a complete Bluetooth system, meeting the Bluetooth RF requirements.

From the Bluetooth system point of view the PCF26100 is a transparent adaptation device between the baseband controller and the UAA3558 radio.

3 ORDERING INFORMATION

TYPE NUMBER	PACKAGE		
	NAME	DESCRIPTION	VERSION
PCF26100ET	TFBGA48	plastic thin fine-pitch ball grid array package; 48 balls; 5 × 5 × 0.8 mm	SOT641-1

Bluetooth Adapter IC

PCF26100

4 BLOCK DIAGRAM

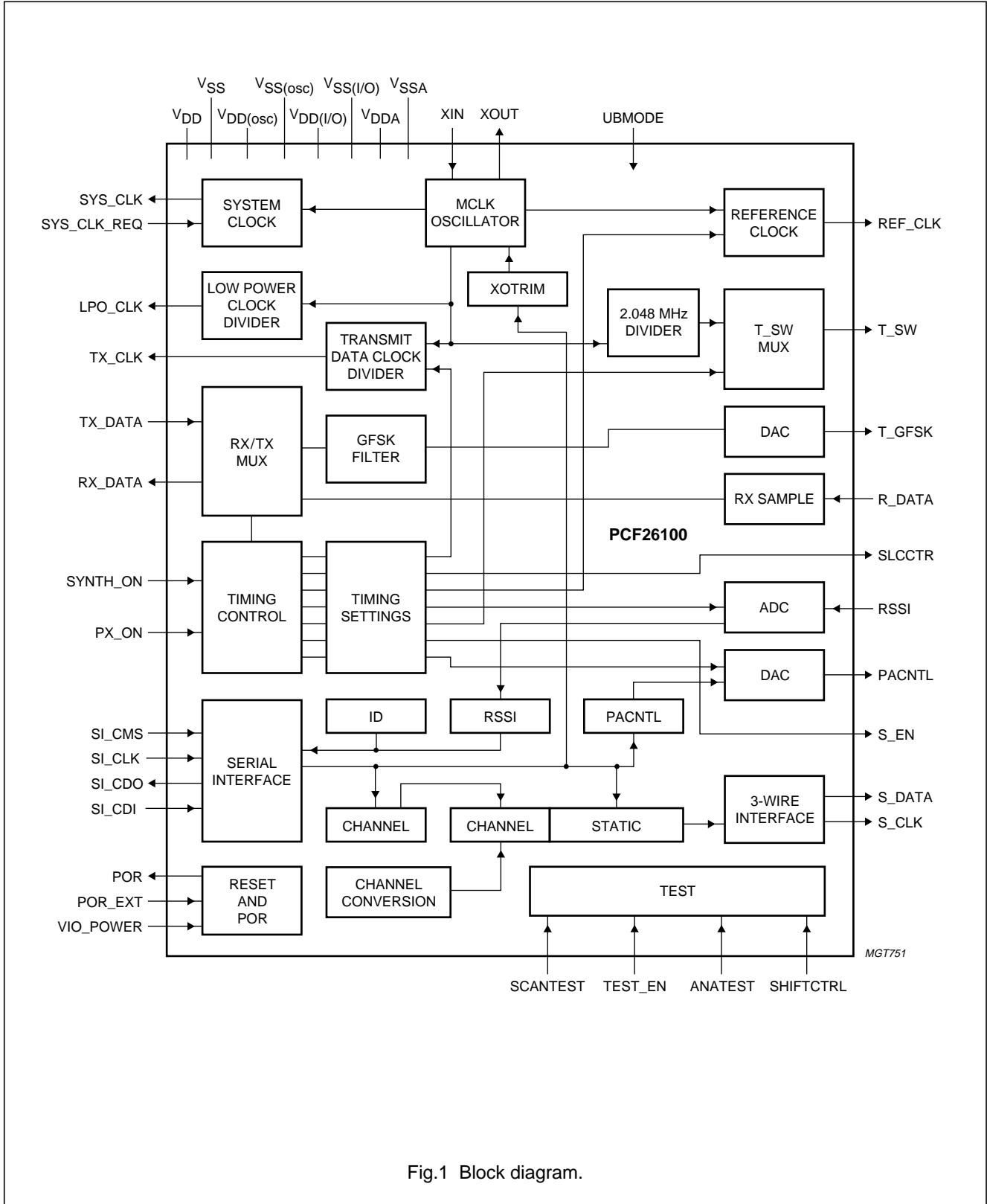

Fig.1 Block diagram.

Bluetooth Adapter IC

PCF26100

5 PINNING INFORMATION

5.1 Pinning

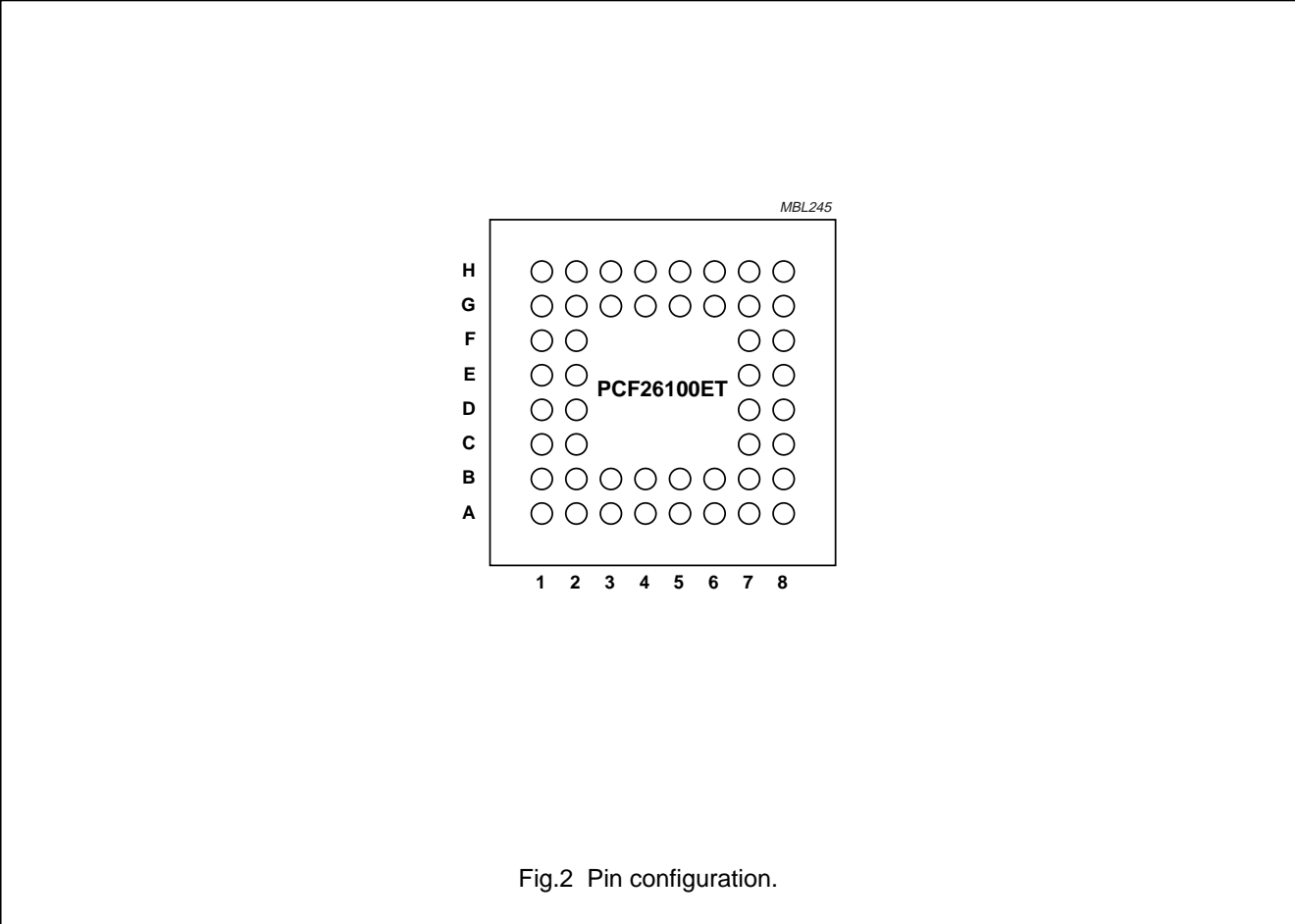

Fig.2 Pin configuration.

Bluetooth Adapter IC

PCF26100

5.2 Pin description

Table 1 Pin description for the TFABGA48 package

SYMBOL	BALL	DESCRIPTION	I/O	SIGNAL TYPE	SOURCE
POR	A1	reset output to baseband controller	O	1 × CMOS output	BB
SHIFTCTRL	C2	test mode	I	non-inverting CMOS input with pull-down	test
VIO_POWER	B1	power-on reset reference	I	Schmitt-trigger input	
V _{DD}	C1	core supply voltage	P	core power	
LPO_CLK	D1	3.2 kHz low-power clock to baseband controller	O	1 × CMOS output	BB
PX_ON	E1	receive packet synchronization correlation achieved	I	non-inverting CMOS input	BB
V _{SS(I/O)}	E2	I/O ground supply	P	I/O ground	
SYS_CLK_REQ	F1	system clock control input from baseband controller	I	non-inverting CMOS input	BB
SYS_CLK	G1	controlled system clock output to baseband controller	O	3 × CMOS output	BB
TX_CLK	F2	transmit data clock output to baseband controller	O	1 × CMOS output	BB
V _{SS}	G2	core ground supply	P	core ground	
RX_DATA	H1	receive data output to baseband controller	O	1 × CMOS output	BB
ANATEST	G3	test mode	I	non-inverting CMOS input with pull-down	test
V _{SS(osc)}	H2	oscillator ground supply	P	oscillator ground	
XOUT	H3	oscillator output	O	oscillator output	misc
XIN	H4	oscillator input	I	oscillator input	misc
V _{DD(osc)}	H5	oscillator supply voltage	P	oscillator power	
V _{DD(I/O)}	G5	I/O supply voltage	P	I/O power	
POR_EXT	H6	reset and POR on control input	I	non-inverting CMOS input	host
TEST_EN	H7	test mode	I	non-inverting CMOS input with pull-down	test
SLCCTR	G6	DC offset control to UAA3558	O	1 × CMOS output	
V _{SS(I/O)}	G7	I/O ground supply	P	I/O ground	
S_EN	H8	serial interface and timing control output to UAA3558	O	1 × CMOS output	UAA
S_CLK	F7	serial interface clock output to UAA3558	O	1 × CMOS output	UAA
S_DATA	G8	serial interface data output to UAA3558	O	1 × CMOS output	UAA
REF_CLK	F8	reference clock output to UAA3558	O	3 × CMOS output	UAA
V _{SSA}	E8, D8	analog ground supply	P	analog ground	
RSSI	D7	RSSI analog input from UAA3558	I	analog input	UAA
T_GFSK	C8	analog transmit data output to UAA3558	O	analog output	UAA

Bluetooth Adapter IC

PCFF26100

SYMBOL	BALL	DESCRIPTION	I/O	SIGNAL TYPE	SOURCE
PACNTL	B8	analog PA control output to external PA	O	analog output	misc
V _{DDA}	C7	analog supply voltage	P	analog power	
R_DATA	B7	receive data input from UAA3558 (UAA3558 output = 0 to 2.2 V)	I	non-inverting CMOS input	UAA
T_SW	A8	transmit switch timing control to UAA3558 multiplexed with 2.048 MHz clock output	O	3 × CMOS output	UAA
SCANTEST	B6	test mode	I	non-inverting CMOS input with pull-down	test
TX_DATA	A7	transmit data	I	non-inverting CMOS input	BB
V _{SS(I/O)}	A6	I/O ground supply	P	I/O ground	
SYNTH_ON	A5	timing control input from baseband controller	I	non-inverting CMOS input	BB
UBMODE	A4	unidirectional/bidirectional mode selection	I	non-inverting CMOS input	misc
V _{DD(I/O)}	B4	I/O supply voltage	P	I/O power	
SI_CLK	A3	serial interface clock input from baseband controller	I	non-inverting CMOS input	BB
SI_CMS	A2	serial interface mode select input from baseband controller	I	non-inverting CMOS input	BB
SI_CDI	B3	serial interface data input from baseband controller	I	non-inverting CMOS input	BB
SI_CDO	B2	serial interface data output to baseband controller	O	1 × CMOS output	BB

Bluetooth Adapter IC

PCF26100

6 FUNCTIONAL DESCRIPTION

6.1 PCF26100 overview

The adapter features a Power-on reset which is used to reset the adapter logic. There is also a POR_EXT signal which is used for controlling the reset of the PCF26100 within the application.

The system clock for the application is generated by the PCF26100. The system clock is then provided to the baseband SYS_CLK and the radio REF_CLK. Both the SYS_CLK and REF_CLK clocks are controlled within the PCF26100.

From the system clock a low-power 3.2 kHz clock LPO_CLK is generated.

From the PCF26100 a 1 MHz TX_CLK is generated to be used in the baseband controller to clock out the transmit data on TX_DATA.

The serial interface to the baseband controller is a JTAG interface. This interface is used to initialize and control the PCF26100 and subsequently the radio. The channel information received from the JTAG interface is converted and forwarded to the radio 3-wire S-bus interface.

The timing control signals to the UAA3558 radio are generated in the PCF26100. For this a minimum number of reference timing signals from the baseband controller are used. The exact timing of the control signals is programmable in the PCF26100.

The PCF26100 converts the digital transmit data from the baseband controller to analog gaussian shaped transmit data to the radio.

The analog RSSI from the radio is converted to digital and made available to the baseband controller via the JTAG interface.

The digital power amplifier control information communicated from the baseband controller to the PCF26100 is converted to an analog control voltage for the radio.

The PCF26100 provides an identification number, which can be read by the baseband controller through the JTAG interface.

For frequency compensation and tuning, the PCF26100 provides a tuning capability on the system oscillator.

6.2 BlueRF pin mapping

Table 2 Adapter and BlueRF unidirectional pin mapping.

ADAPTER TO BASEBAND PIN NAME	BLUERF PIN NAME JTAG UNIDIRECTIONAL RXMODE 2
POR_EXT	BnPWR
POR	not applicable
LPO_CLK	not applicable
SYS_CLK	not applicable
SYS_CLK_REQ	BXTLEN
TX_CLK	BRCLK
TX_DATA	BTXD/BDATA1
RX_DATA	BRXD
SYNTH_ON	BSEN
PX_ON	BPKTCTL/BDATA2
SI_CMS	BnDEN
SI_CLK	BDCLK
SI_CDI	BMOSI/BDDATA
SI_CDO	BMISO
VIO_POWER	not applicable

Bluetooth Adapter IC

PCF26100

6.3 Timing

The timing for the radio is generated in the PCF26100 using a minimal number of baseband signals. The channel programming is received from the JTAG serial interface. The SYNTH_ON signal is used to determine the start and end of the packet. The radio SLCCTR signals is also controlled with PX_ON.

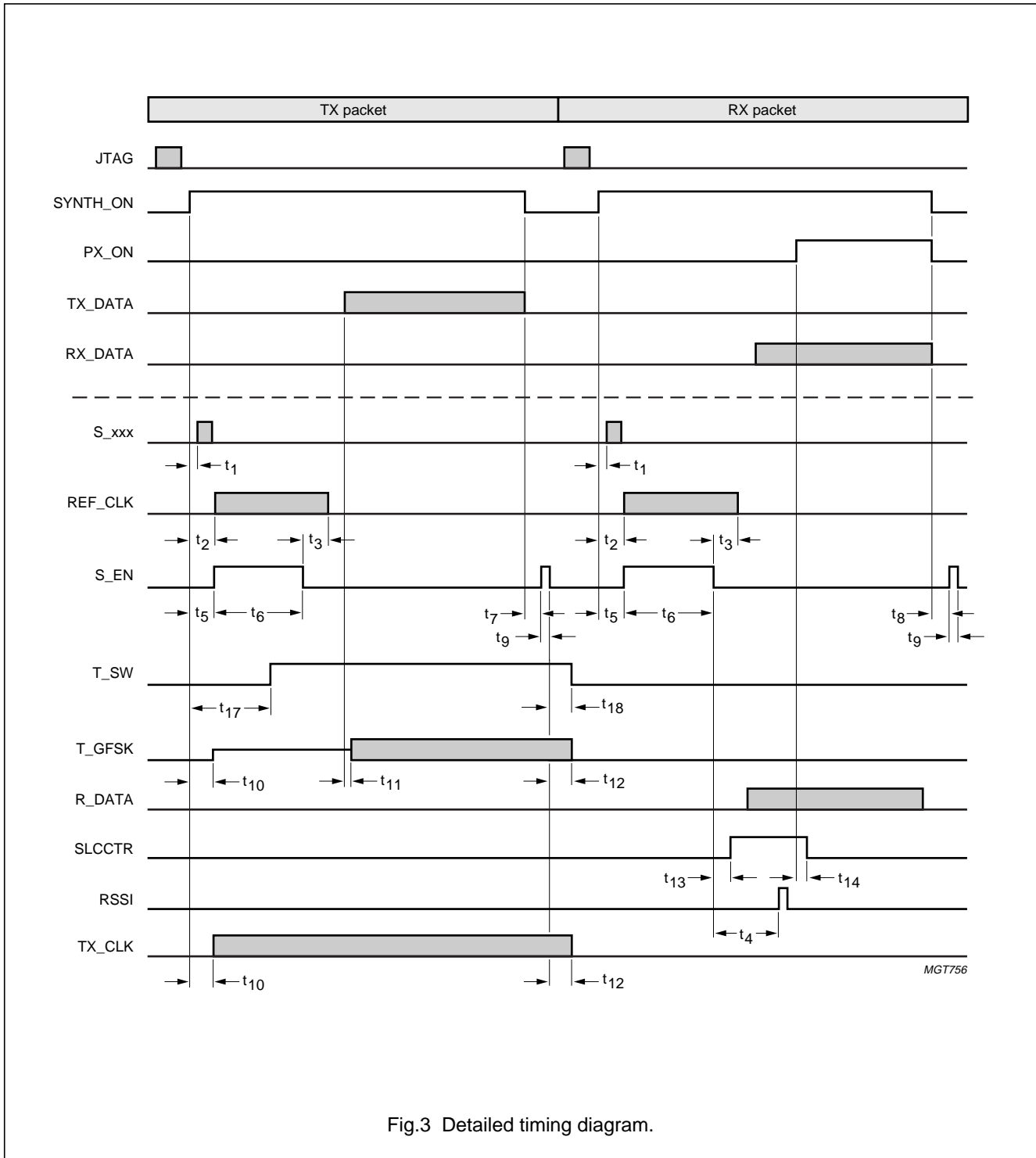

Fig.3 Detailed timing diagram.

Bluetooth Adapter IC

PCF26100

Table 3 Adapter timing parameters

PARAMETER	DESCRIPTION	VALUE	UNIT
t ₁	SYNTH_ON rising edge to 3-wire serial data	0.35	µs
t ₂	SYNTH_ON rising edge to REFCLK start	S_EN start	µs
t ₃	S_EN falling edge to REFCLK stop delay	2	µs
t ₄	S_EN falling edge to RSSI measurement	RSSI_start	µs
t ₅	SYNTH_ON rising edge to S_EN rising edge	S_EN start	µs
t ₆	S_EN width	S_EN width	µs
t ₇	SYNTH_ON falling edge to S_EN pulse rising edge	S_EN pulse start	µs
t ₈	SYNTH_ON falling edge to S_EN pulse rising edge	S_EN pulse start	µs
t ₉	S_EN pulse width	2	µs
t ₁₀	SYNTH_ON rising edge to T_GFSK DC bias and TXCLK enable	GFSK_DC_bias start	µs
t ₁₁	TX_DATA digital in to T_GFSK analog out delay	14	13 MHz cycles
t ₁₂	S_EN pulse falling edge to T_GFSK LOW and TXCLK disable	0	µs
t ₁₃	S_EN falling edge to SLCCTR rising edge	SLCCTR start	µs
t ₁₄	PX_ON rising edge to SLCCTR falling edge	0	µs
t ₁₇	SYNTH_ON rising edge to T_SW rising edge	T_SW start	µs
t ₁₈	S_EN pulse falling edge to T_SW falling edge	0	µs

6.3.1 T_GFSK

The T_GFSK data output has 3 phases:

1. Idle phase
2. DCbias phase
3. Txdata phase.

The Idle phase is used outside transmit packets. In this phase the T_GFSK output state is defined by the 'gfsk float' bit in the Enable Register. If the 'gfsk float' bit is set to a logic 0, the T_GFSK output is pulled to ground; if set to a logic 1 the T_GFSK output is floating.

The DCbias phase is used during the transmit slot as start-up phase before the transmit data. The DCbias phase is active GFSK_DC_BIAS_Start delay following the S_EN rising edge until the first transmit data bit on TX_DATA.

During this phase a DC bias is generated by the GFSK filter, which is achieved by selecting the GFSK table mid-value as the output of the GFSK filter.

The Txdata phase is used when TXDATA is present.

In this phase the TX_DATA is fed into the GFSK filter. The presence of TXDATA is determined by detecting the first TXDATA edge. The end of the TXDATA is detected by the end of packet from the baseband controller. To not lose TXDATA information in the T_GFSK output, due to the data detection, the data from the GFSK input is delayed with 1-bit.

The T_GFSK output requires an external low-pass filter. The reference voltage for the T_GFSK comes directly from the V_{D_{DA}} power supply. Any variation on V_{D_{DA}} has a direct relation to a variation in the T_GFSK levels. The V_{D_{DA}} power supply should be provided from a voltage reference.

The TX_CLK output is activated during the DC_BIAS phase and the Txdata phase.

Bluetooth Adapter IC

PCF26100

6.3.2 RESET

The PCF26100 is reset with a Power-on reset using the VIO_POWER signal. This will reset all registers and put the device into a known state. The POR_EXT reset signal will also reset the device and put it in the same state as the Power-on reset. However, POR_EXT is intended to be used for a reset from a host.

Following the Power-on reset or a reset by POR_EXT, the system oscillator is started and the SYS_CLK output is activated (enabled). The SYS_CLK output can be controlled by the SYS_CLK_REQ signal but only if the 'rdy' bit in the Control Register has been set to logic 1.

The function of SYS_CLK_REQ has 2 phases:

1. After reset, SYS_CLK_REQ is not taken into account for the generation of SYS_CLK. After reset the 13 MHz system clock is enabled on SYS_CLK.
2. Once the 'rdy' bit is set to logic 1, the 13 MHz clock on the SYS_CLK is controlled with SYS_CLK_REQ.

The SYS_CLK_REQ signal will not control or disable the oscillator.

The LPO_CLK output is only controlled by the POR_EXT signal which also controls the POR output. The POR is activated 4 SYS_CLK cycles after POR_EXT.

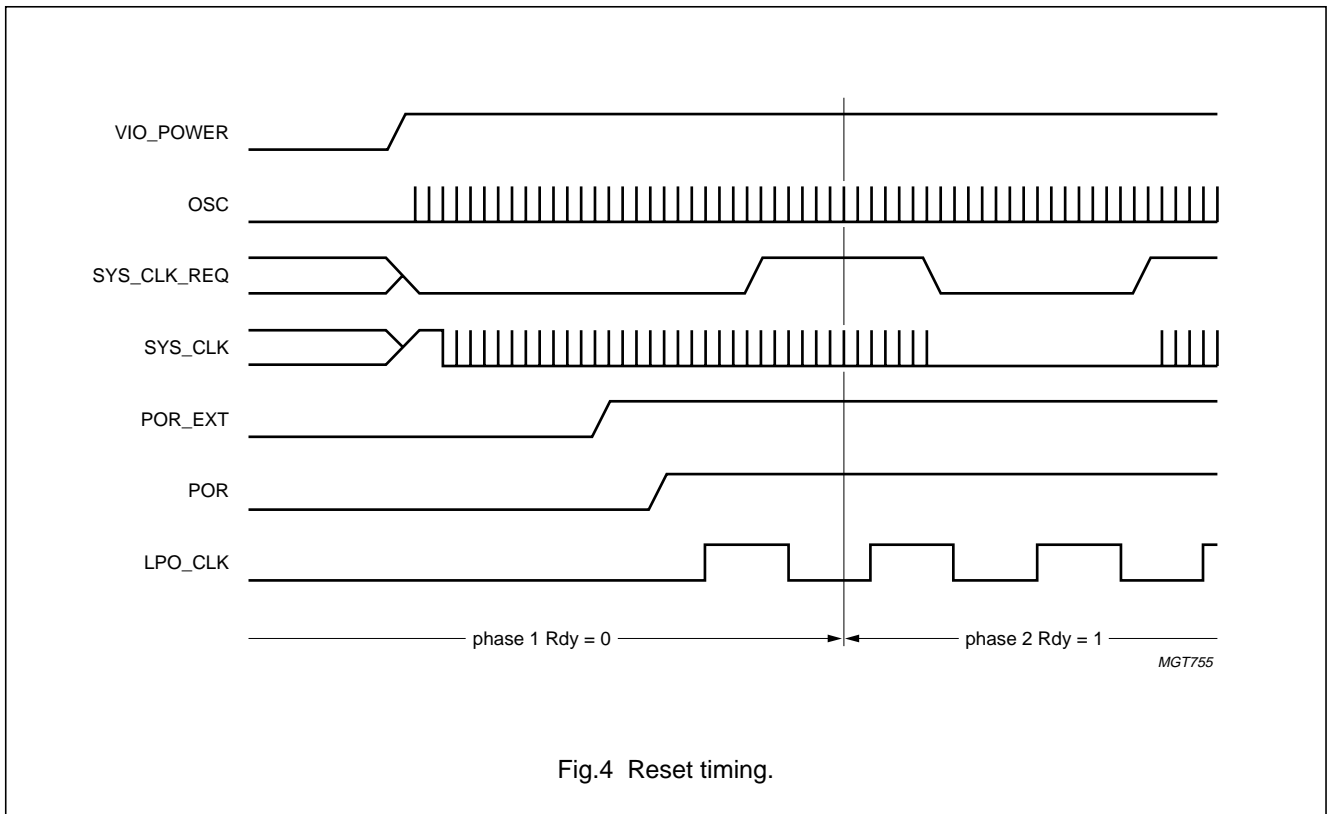

Fig.4 Reset timing.

Bluetooth Adapter IC

PCF26100

6.4 Serial interface**6.4.1 3-WIRE S-BUS**

The 3-wire S-bus at the radio side is a 32-bit serial interface which is used for control, TX/RX and channel information. The 32-bit definition is given in Tables 4 and 5.

Bits 31 to 9 are static values and will not change dynamically, the value for these bits come from the static registers. Only the *trx* and *main divider* fields will control the UAA3558 on a slot-by-slot basis. The *trx* and *main divider* information comes from the baseband controller serial interface channel word; see Section 6.5.1. However, the baseband controller channel information needs a conversion to get the correct *main divider* information for the UAA3558.

Table 4 UAA3558 3-wire programming word

31	30	29	28	27	26	25	24	23	22	21	20	19	18	17	16
test				dpo	BW adjust			strc	sdsn	sdco	ssqs	ssth	dmo	tin	

Table 5 UAA3558 3-wire programming word (continued)

15	14	13	12	11	10	9	8	7	6	5	4	3	2	1	0
tsw	tamp	ref1	ref0	txp1	txp0	pll	trx	main divider (n)							

6.4.2 JTAG

The JTAG serial interface is used to control the PCF26100 and subsequently the radio. The PCF26100 must be the only slave on the JTAG bus as the PCF26100 does not allow for multi-slave operation. The JTAG interface protocol used is fully compliant with the standard set out in "IEEE Std 1149.1-1990". The following features are supported:

- 5-bit register address
- 8-bit data
- Set instruction register
- Read/write data register (note: some addresses have a separate read and write data register).

The JTAG interface allows for 2 ways of accessing a register. One is the communicate address and data, and the second one is for successive accesses to the same registers where only the data is communicated. This can, for example, be used for updating the channel information before every packet.

Bluetooth Adapter IC

PCF26100

6.5 Registers

The registers that are controlled via the serial interface are shown in Table 6.

Table 6 Register map

REGISTER	TYPE	ADDRESS (DECIMAL)	RESET (HEX)	DESCRIPTION
S_EN_start	R/W	8	0C	S_EN start delay
S_EN_width	R/W	9	C8	S_EN width
T_SW_start	R/W	10	64	T_SW start delay
SLCCTR_start	R/W	11	0A	SLCCTR start delay
S_EN_PULSE_start	R/W	12	02	S_EN pulse start delay
RSSI_start	R/W	13	64	RSSI measurement position
STATIC_B15_9	R/W	14	24	UAA3558 serial word static values
STATIC_B23_16	R/W	15	12	UAA3558 serial word static values
STATIC_B31_24	R/W	16	00	UAA3558 serial word static values
CHANNEL	W	18	00	frequency channel number and TX/RX information
RSSI	R	18	00	RSSI
XO-trim	W	19	80	trim value for the system clock oscillator
ID	R	19	A1	device identification
CONTROL	R/W	22	00	system clock control
PACONTROL	R/W	24	00	for external PA power control
ENABLE	R/W	25	00	adapter control
GFSK_DC_BIAS_start	R/W	26	64	GFSK DC bias start delay
GFSK_TABLE	R/W	28	00	GFSK look-up table values
RXFREQ	W	30	61	RX channel conversion number
TXFREQ	W	31	60	TX channel conversion number

6.5.1 CHANNEL PROGRAMMING

The serial interface channel programming word is forwarded to the UAA3558 3-wire interface. The channel information cannot normally be used directly and needs a conversion to get the right number for the UAA3558.

Table 7 Channel programming word

ADDRESS	7	6	5	4	3	2	1	0
18 (decimal)	trx	channel number (m)						

Table 8 Description of Channel programming word bits

BIT	DESCRIPTION
7	If trx = 0, then device in Transmit mode. If trx = 1, then device in Receive mode.
6 to 0	These 7 bits determine the channel number (m).

Bluetooth Adapter IC

PCF26100

6.5.2 FREQUENCY CHANNEL CONVERSION

The conversion number is programmable for TX and RX. The function implemented is:

TX frequency = 2304 + m + TXFREQ; where m is the BT channel number and TXFREQ is programmable between 0 and 255

RX frequency = 2304 + m + RXFREQ; where m is the BT channel number and RXFREQ is programmable between 0 and 255.

Table 9 Frequency conversion word RXFREQ

ADDRESS	7	6	5	4	3	2	1	0
30 (decimal)	RXFREQ							

Table 10 Frequency conversion word TXFREQ

ADDRESS	7	6	5	4	3	2	1	0
31 (decimal)	TXFREQ							

6.5.3 STATIC VALUES

The UAA3558 bits 31 to 9 are static values and will not change dynamically. These values are programmed into the adapter via the serial interface. The static words are: STATIC_B15_9, STATIC_B23_16 and STATIC_B31_24.

Table 11 Static word STATIC_B15_9

ADDRESS	7	6	5	4	3	2	1	0
14 (decimal)	static value bits 15 to 9							not used

Table 12 Static word STATIC_B23_16

ADDRESS	7	6	5	4	3	2	1	0
15 (decimal)	static value bits 23 to 16							

Table 13 Static word STATIC_B31_24

ADDRESS	7	6	5	4	3	2	1	0
16 (decimal)	static value bits 31 to 24							

Bluetooth Adapter IC

PCF26100

6.5.4 TIMING VALUES

The UAA3558 needs some timing signals which do not have a corresponding signal at the BlueRF interface. These signals are generated internally in the adapter. The timing values for these will not change dynamically. These values are programmed into the adapter via the serial interface. The timing words are: S_EN_start, S_EN_width, T_SW_start, SLCCTR_start, S_EN_PULSE_start, RSSI_start, and GFSK_DC_bias.

Table 14 Timing control word S_EN_start

ADDRESS	7	6	5	4	3	2	1	0
8 (decimal)	programmed timing value (resolution of 1-bit = 1 μ s)							

Table 15 Timing control word S_EN_width

ADDRESS	7	6	5	4	3	2	1	0
9 (decimal)	programmed timing value (resolution of 1-bit = 1 μ s)							

Table 16 Timing control word T_SW_start

ADDRESS	7	6	5	4	3	2	1	0
10 (decimal)	programmed timing value (resolution of 1-bit = 1 μ s)							

Table 17 Timing control word SLCCTR_start

ADDRESS	7	6	5	4	3	2	1	0
11 (decimal)	programmed timing value (resolution of 1-bit = 1 μ s)							

Table 18 Timing control word S_EN_PULSE_start

ADDRESS	7	6	5	4	3	2	1	0
12 (decimal)	programmed timing value (resolution of 1-bit = 1 μ s)							

Table 19 Timing control word RSSI_start

ADDRESS	7	6	5	4	3	2	1	0
13 (decimal)	programmed timing value (resolution of 1-bit = 1 μ s)							

Table 20 Timing control word GFSK_DC_bias

ADDRESS	7	6	5	4	3	2	1	0
26 (decimal)	programmed timing value (resolution of 1-bit = 1 μ s)							

Bluetooth Adapter IC

PCF26100

Table 21 Register values range and actual timings

REGISTER	RANGE	TIMING	ACTUAL VALUE	UNIT
S_EN_START	0 < x < 256	t ₂ and t ₅	S_EN_START + (0 to 1)	μs
S_EN_WIDTH	0 < x < 256	t ₆	S_EN_WIDTH	μs
T_SW_START	S_EN_START < x < 256	t ₁₇	T_SW_START + (0 to 1)	μs
SLCCTR_START	0 < x < 256	t ₁₃	SLCCTR_START + 1	μs
S_EN_PULSE_DEL	0 < x < 256	t ₇ and t ₈	S_EN_PULSE_DEL + (0 to 1)	μs
RSSI_START	0 < x < 256	t ₄	RSSI_START	μs
GFSK_DC_BIAS	0 < x < 256	t ₁₀	GFSK_DC_BIAS + (0 to 1)	μs

6.5.5 RSSI

The RSSI is read via the serial interface. The UAA3558 provides an analog RSSI output. The interface logic converts the analog RSSI value and stores the result in a serial interface register. The timing for converting the RSSI is programmed using the RSSI_start register. The RSSI can only be measured starting 10 μs after the S_EN falling edge. The RSSI value can only be read from the serial interface register after the measurement has been completed, this is at the end of the packet. RSSI measurements are only done in receive packets.

Table 22 RSSI control word

ADDRESS	7	6	5	4	3	2	1	0
18 (decimal)	RSSI							

6.5.6 TRANSMIT POWER CONTROL

The transmit power can be controlled from a serial interface register. The 8-bit transmit power control word is used to control the PA DAC. Writing to the PA DAC register will directly change the PA DAC output. The PA control register should be written when the transmitter is not active.

Table 23 Unidirectional JTAG PA control word

ADDRESS	7	6	5	4	3	2	1	0
24 (decimal)	PA power control							

6.5.7 GFSK TABLE

The values for the GFSK filter are stored in a 13-byte GFSK table. The GFSK table is accessed through a single control word which is used to store the data in the GFSK table on subsequent writes. To align the writing to the GFSK table a table address reset bit is available in the Enable register. When the reset bit 'grst' in the Enable register is set to a logic 1 the GFSK table address will be reset and the next GFSK control word is written at location 0 in the GFSK table. Every subsequent write to the GFSK control word will be stored at the next address in the GFSK table. If the last address is reached, subsequent writes will continue to effect the last address.

The values for the GFSK table depend on the reference voltage on V_{DDA}. The T_GFSK signal should have a DC_Bias of 1.2 V with a peak-to-peak swing of 1 V (amplitude = 0.5 V). For this the values for the GFSK table are calculated as shown in Table 26.

Table 24 Unidirectional JTAG GFSK control word

GFSK_TABLE	7	6	5	4	3	2	1	0
28 (decimal)	GFSK table value							

Bluetooth Adapter IC

PCF26100

Table 25 GFSK table reset values

TABLE ADDRESS (DECIMAL)	RESET VALUE (HEX)
12	91
11	90
10	8E
9	89
8	81
7	74
6	64
5	54
4	47
3	3E
2	3A
1	38
0	37

Table 26 GFSK value calculation

TABLE ADDRESS (DECIMAL)	CALCULATION ⁽¹⁾	VALUE AT 3 V	
		DECIMAL	HEX
0	$[\text{DCBias} + (A \times -96)] \times B$	59	3B
1	$[\text{DCBias} + (A \times -94)] \times B$	60	3C
2	$[\text{DCBias} + (A \times -90)] \times B$	62	3E
3	$[\text{DCBias} + (A \times -80)] \times B$	66	42
4	$[\text{DCBias} + (A \times -62)] \times B$	74	4A
5	$[\text{DCBias} + (A \times -34)] \times B$	87	57
6	$[\text{DCBias} + (A \times 0)] \times B$	102	66
7	$[\text{DCBias} + (A \times 34)] \times B$	117	75
8	$[\text{DCBias} + (A \times 62)] \times B$	130	82
9	$[\text{DCBias} + (A \times 80)] \times B$	138	8A
10	$[\text{DCBias} + (A \times 90)] \times B$	142	8E
11	$[\text{DCBias} + (A \times 94)] \times B$	144	90
12	$[\text{DCBias} + (A \times 96)] \times B$	145	91

Note

1. Where $A = \frac{\text{Amp}}{96}$ and $B = \frac{255}{V_{\text{DDA}}}$

Bluetooth Adapter IC

PCF26100

6.5.8 CONTROL REGISTER (CONTROL)

The Control Register is used to control SYS_CLK in the adapter.

Table 27 Control Register

ADDRESS	7	6	5	4	3	2	1	0
22 (decimal)	–	–	–	–	–	rdy	–	–

Table 28 Description of CONTROL bits

BIT	SYMBOL	DESCRIPTION
7 to 3	–	These 5 bits are reserved and are not to be used.
2	rdy	Baseband ready. This bit is used to control the function of SYS_CLK_REQ.
1	–	These 2 bits are reserved and are not to be used.
0	–	

6.5.9 ENABLE REGISTER (ENABLE)

The Enable Register is used to control functions in the adapter.

Table 29 Enable Register

ADDRESS	7	6	5	4	3	2	1	0
25 (decimal)	gfsk float	grst	pa float	clk en	test.2	test.1	test.0	–

Table 30 Description of ENABLE bits

BIT	SYMBOL	DESCRIPTION
7	gfsk float	Controls the T_GFSK output outside TX packet. If gfsk = 0, then output tied to ground. If gfsk = 1, then output floats.
6	grst	GFSK table address reset. Writing a logic 1 will reset the GFSK table addressing.
5	pa float	Controls the PA output outside TX packet. If pa float = 0, then output tied to ground. If pa float = 1, then output floats.
4	clk en	Enables the 2.048 MHz clock on T_SW. If clk en = 0, then pin T_SW = T_SW. If clk en = 1, then pin T_SW = 2.048 MHz.
3	test.2	These 3 bits are used for test purposes.
2	test.1	
1	test.0	
0	–	This bit is reserved and should not be used.

Bluetooth Adapter IC

PCF26100

6.5.10 OSCILLATOR TRIM REGISTER (XO_TRIM)

The Oscillator Trim Register is used to control the frequency of the 13 MHz oscillator. This is achieved by controlling the capacitive load on the XIN and XOUT pins.

Table 31 Oscillator Trim Register

ADDRESS	7	6	5	4	3	2	1	0
19 (decimal)	–	XO_trim. 6	XO_trim. 5	XO_trim. 4	XO_trim. 3	XO_trim. 2	XO_trim. 1	XO_trim. 0

Table 32 Description of XO_trim bits

BIT	SYMBOL	DESCRIPTION
7	–	This bit is reserved and should not be used.
6	XO_trim.6	add 6 pF to XIN and XOUT
5	XO_trim.5	add 3 pF to XIN and XOUT
4	XO_trim.4	add 1.5 pF to XIN and XOUT
3	XO_trim.3	add 0.75 pF to XIN and XOUT
2	XO_trim.2	add 0.375 pF to XIN and XOUT
1	XO_trim.1	add 0.1875 pF to XIN and XOUT
0	XO_trim.0	add 0.09375 pF to XIN and XOUT

6.5.11 IDENTIFICATION REGISTER (ID)

The Identification Register is used to identify the radio chip set from the baseband controller. This is a read only register.

Table 33 Identification Register

ADDRESS	7	6	5	4	3	2	1	0
19 (decimal)	ID.7	ID.6	ID.5	ID.4	ID.3	ID.2	ID.1	ID.0

Table 34 Description of ID bits

BIT	SYMBOL	DESCRIPTION
7 to 0	ID.[7:0]	These 8 bits determine the radio chip set identification (value = A1H).

7 REFERENCE DOCUMENTS

1. UAA3558 Bluetooth RF Transceiver (Philips data sheet).
2. PCF26002 Bluetooth baseband controller (Philips data sheet).
3. BlueRF specification (ARM Ltd).

Bluetooth Adapter IC

PCF26100

8 LIMITING VALUES

In accordance with the Absolute Maximum Rating System (IEC 60134).

SYMBOL	DESCRIPTION	MIN.	MAX.	UNIT
V_{DD}	core supply voltage	$V_{SS} - 0.5$	$V_{SS} + 3.6$	V
V_{DDA}	analog supply voltage	$V_{SS} - 0.5$	$V_{SS} + 3.6$	V
$V_{DD(I/O)}$	I/O supply voltage	$V_{SS} - 0.5$	$V_{SS} + 3.6$	V
$V_{DD(osc)}$	oscillator supply voltage	$V_{SS} - 0.5$	$V_{SS} + 3.6$	V
V_{in}	input voltage	$V_{SS} - 0.5$	$V_{DD} + 0.3$	V
T_{stg}	storage temperature	-50	+150	°C
T_{oper}	operating temperature	0	+70	°C

9 DC CHARACTERISTICS

SYMBOL	DESCRIPTION	MIN.	TYP.	MAX.	UNIT
V_{DD}	core supply voltage	2.7	3.0 to 3.3	3.6	V
V_{DDA}	analog supply voltage for ADC and DAC; note 1	2.7	3.0 to 3.3	3.6	V
$V_{DD(I/O)}$	I/O supply voltage	2.7	3.0 to 3.3	3.6	V
$V_{DD(osc)}$	oscillator supply voltage	2.7	3.0 to 3.3	3.6	V
P_{tx}	transmit power consumption	-	22	-	mW
P_{rx}	receive power consumption	-	14	-	mW
P_{stb}	standby power consumption; note 2	-	3	-	mW
V_{IL}	LOW-level input voltage	-0.5	-	$+0.3V_{DD(I/O)}$	V
V_{IH}	HIGH-level input voltage	$0.7V_{DD(I/O)}$	-	$V_{DD} + 0.3$	V
V_{OL}	LOW-level output voltage	-	-	0.5	V
V_{OH}	HIGH-level output voltage	2.4	-	-	V
I_{LI}	input leakage current	-10	-	+10	μA

Notes

- V_{DDA} should be supplied from a stable source.
- Standby power consumption is measured when $SYS_CLK_REQ = 0$.

Bluetooth Adapter IC

PCF26100

10 AC CHARACTERISTICS

SYMBOL	DESCRIPTION	MIN.	TYP.	MAX.	UNIT
Frequency					
f_{sys}	system clock frequency	–	13	–	MHz
$f_{\text{clk(LP)}}$	low power clock frequency	–	3.2	–	MHz
$f_{\text{s-bus}}$	3-wire S-bus frequency	–	6.5	–	MHz
f_{JTAG}	JTAG clock frequency	1	–	5	MHz
f_{clock}	2.048 MHz clock output	–	2.048	–	MHz
D_{clock}	duty cycle 2.048 MHz clock output	–	40/60	–	%
RSSI ADC					
$RES_{\text{(ADC)}}$	RSSI ADC resolution	–	8	–	bit
$LE_{\text{(ADC)}}$	RSSI ADC linearity error	–0.5	0	+0.5	LSB
$E_{\text{offset(ADC)}}$	RSSI ADC offset error	–50	0	+50	mV
$E_{\text{FS(ADC)}}$	RSSI ADC full-scale error	–50	0	+50	mV
$V_{\text{i(ADC)}}$	RSSI ADC signal input voltage range	0	–	V_{DDA}	V
$Z_{\text{i(ADC)}}$	RSSI ADC input impedance	–	10	–	$M\Omega$
GFSK DAC					
$RES_{\text{(DAC)}}$	DAC resolution	–	8	–	bit
$LE_{\text{DAC(i)}}$	DAC integral linearity error	–1.0	–	+1.0	LSB
$LE_{\text{DAC(diff)}}$	DAC differential linearity error	–0.5	–	+0.5	LSB
$E_{\text{offset(DAC)}}$	DAC offset error	–50	–	+50	mV
$E_{\text{FS(DAC)}}$	DAC full-scale error	–50	–	+50	mV
$V_{\text{o(DAC)}}$	DAC signal output voltage range	0	–	V_{DDA}	V
$R_{\text{L(DAC)}}$	DAC load resistance	600	–	–	LSB
$C_{\text{L(DAC)}}$	DAC load capacitance	–	–	20	pF

Bluetooth Adapter IC

PCF26100

11 APPLICATIONS

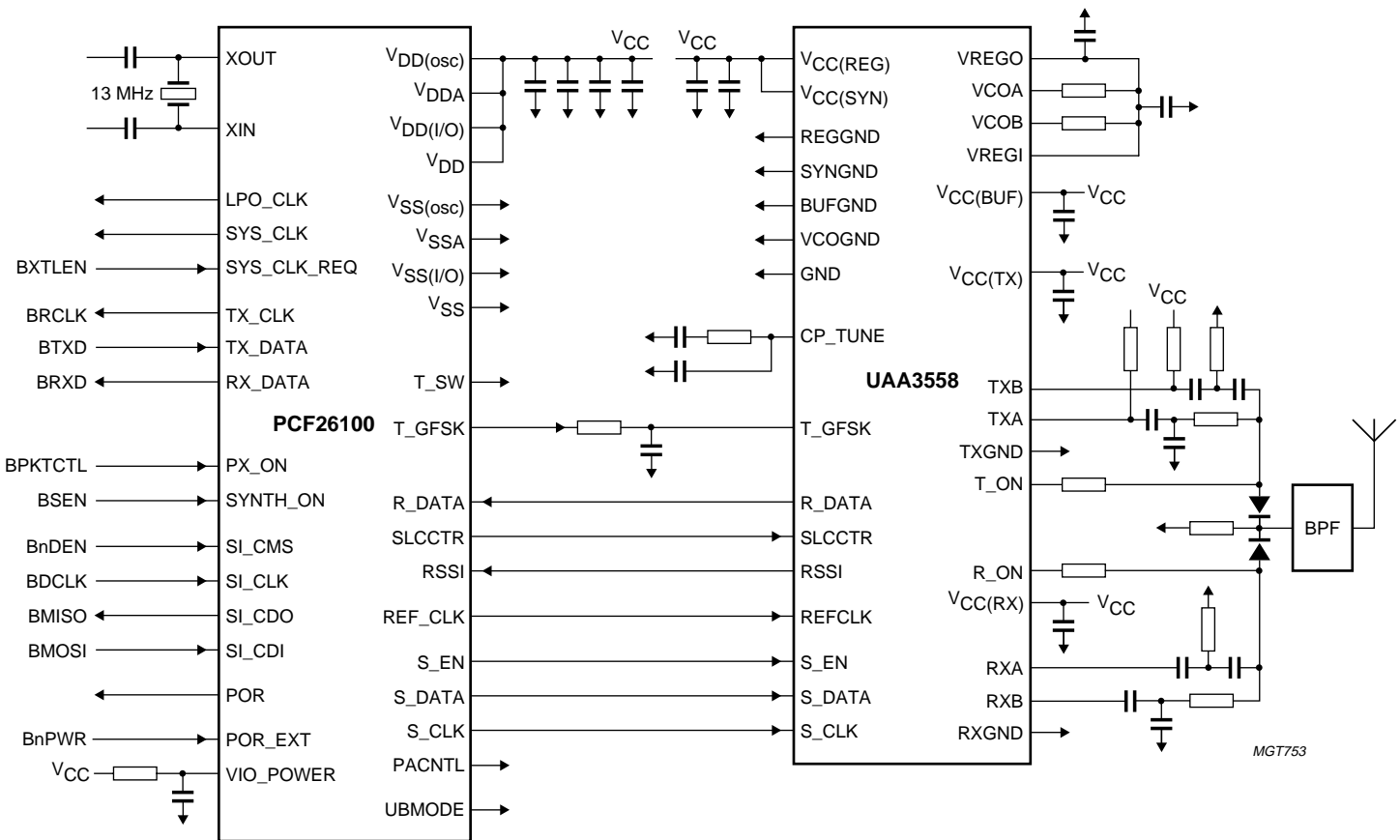

Fig.5 Application diagram BlueRF JTAG Unidirectional RxMode 2.

Bluetooth Adapter IC

PCF26100

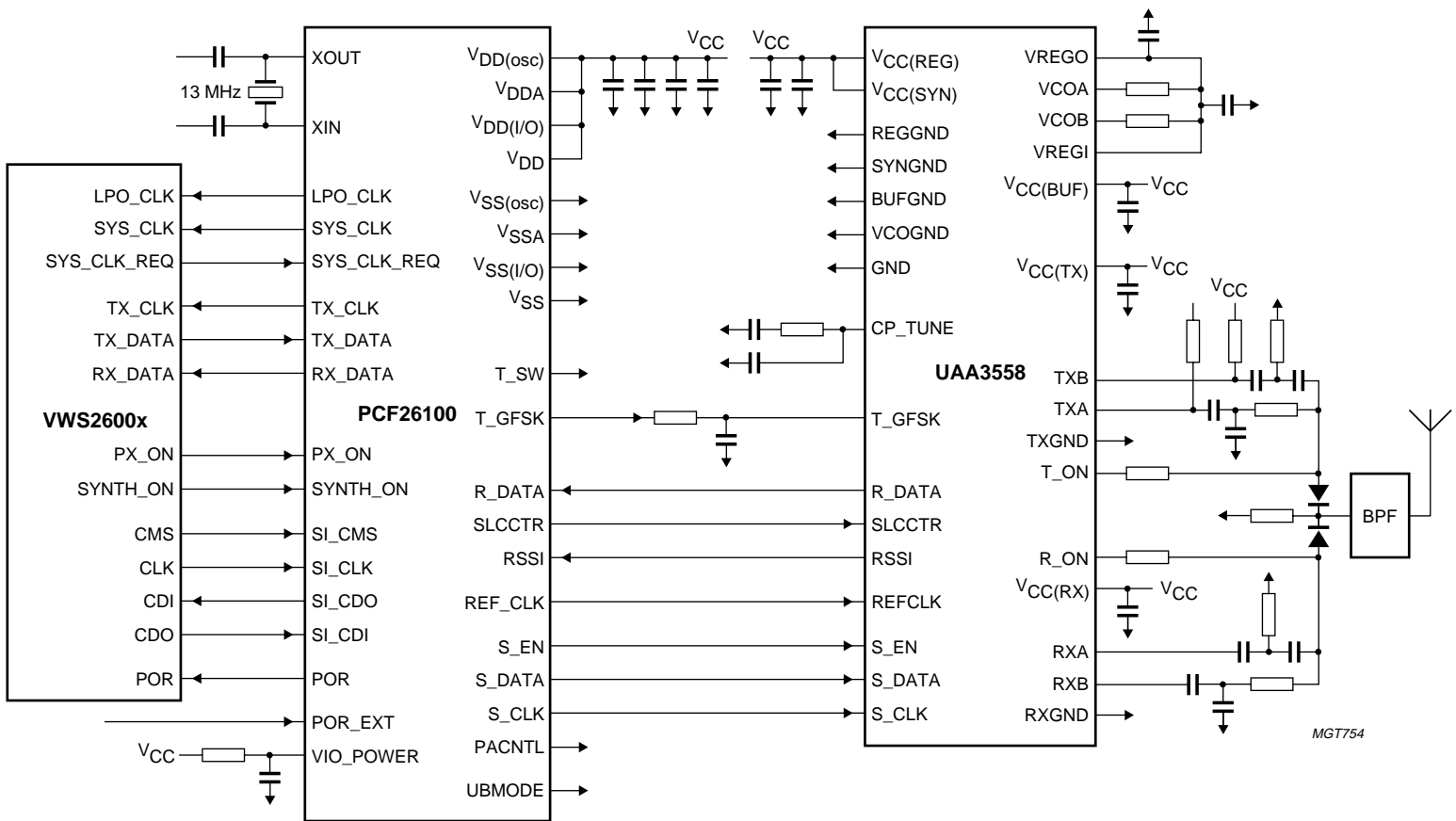

Fig.6 Application diagram VWS2600x.

Bluetooth Adapter IC

PCF26100

12 PACKAGE OUTLINE

TFBGA48: plastic thin fine-pitch ball grid array package; 48 balls; body 5 x 5 x 0.8 mm

SOT641-1

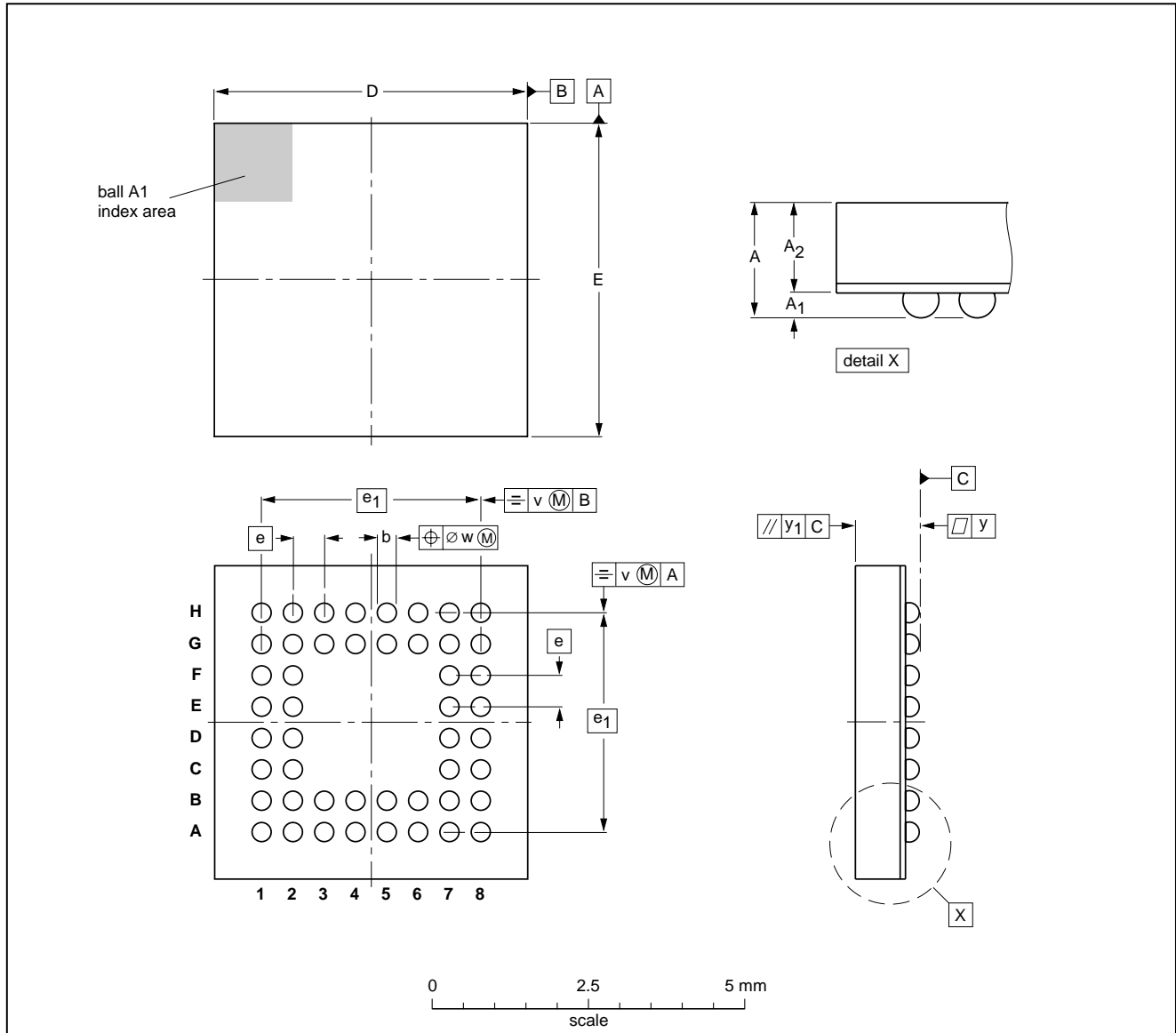

DIMENSIONS (mm are the original dimensions)

UNIT	A max.	A ₁	A ₂	b	D	E	e	e ₁	v	w	y	y ₁
mm	1.12	0.28 0.16	0.84 0.76	0.37 0.27	5.1 4.9	5.1 4.9	0.5	3.5	0.15	0.1	0.12	0.1

OUTLINE VERSION	REFERENCES				EUROPEAN PROJECTION	ISSUE DATE
	IEC	JEDEC	EIAJ			
SOT641-1		MO-211				00-10-10

Bluetooth Adapter IC

PCF26100

13 SOLDERING

13.1 Introduction to soldering surface mount packages

This text gives a very brief insight to a complex technology. A more in-depth account of soldering ICs can be found in our *“Data Handbook IC26; Integrated Circuit Packages”* (document order number 9398 652 90011).

There is no soldering method that is ideal for all surface mount IC packages. Wave soldering can still be used for certain surface mount ICs, but it is not suitable for fine pitch SMDs. In these situations reflow soldering is recommended.

13.2 Reflow soldering

Reflow soldering requires solder paste (a suspension of fine solder particles, flux and binding agent) to be applied to the printed-circuit board by screen printing, stencilling or pressure-syringe dispensing before package placement.

Several methods exist for reflowing; for example, convection or convection/infrared heating in a conveyor type oven. Throughput times (preheating, soldering and cooling) vary between 100 and 200 seconds depending on heating method.

Typical reflow peak temperatures range from 215 to 250 °C. The top-surface temperature of the packages should preferably be kept below 220 °C for thick/large packages, and below 235 °C for small/thin packages.

13.3 Wave soldering

Conventional single wave soldering is not recommended for surface mount devices (SMDs) or printed-circuit boards with a high component density, as solder bridging and non-wetting can present major problems.

To overcome these problems the double-wave soldering method was specifically developed.

If wave soldering is used the following conditions must be observed for optimal results:

- Use a double-wave soldering method comprising a turbulent wave with high upward pressure followed by a smooth laminar wave.
- For packages with leads on two sides and a pitch (e):
 - larger than or equal to 1.27 mm, the footprint longitudinal axis is **preferred** to be parallel to the transport direction of the printed-circuit board;
 - smaller than 1.27 mm, the footprint longitudinal axis **must** be parallel to the transport direction of the printed-circuit board.

The footprint must incorporate solder thieves at the downstream end.

- For packages with leads on four sides, the footprint must be placed at a 45° angle to the transport direction of the printed-circuit board. The footprint must incorporate solder thieves downstream and at the side corners.

During placement and before soldering, the package must be fixed with a droplet of adhesive. The adhesive can be applied by screen printing, pin transfer or syringe dispensing. The package can be soldered after the adhesive is cured.

Typical dwell time is 4 seconds at 250 °C.

A mildly-activated flux will eliminate the need for removal of corrosive residues in most applications.

13.4 Manual soldering

Fix the component by first soldering two diagonally-opposite end leads. Use a low voltage (24 V or less) soldering iron applied to the flat part of the lead. Contact time must be limited to 10 seconds at up to 300 °C.

When using a dedicated tool, all other leads can be soldered in one operation within 2 to 5 seconds between 270 and 320 °C.

Bluetooth Adapter IC

PCF26100

13.5 Suitability of surface mount IC packages for wave and reflow soldering methods

PACKAGE	SOLDERING METHOD	
	WAVE	REFLOW ⁽¹⁾
BGA, LFBGA, SQFP, TFBGA	not suitable	suitable
HBCC, HLQFP, HSQFP, HSOP, HTQFP, HTSSOP, SMS	not suitable ⁽²⁾	suitable
PLCC ⁽³⁾ , SO, SOJ	suitable	suitable
LQFP, QFP, TQFP	not recommended ⁽³⁾⁽⁴⁾	suitable
SSOP, TSSOP, VSO	not recommended ⁽⁵⁾	suitable

Notes

1. All surface mount (SMD) packages are moisture sensitive. Depending upon the moisture content, the maximum temperature (with respect to time) and body size of the package, there is a risk that internal or external package cracks may occur due to vaporization of the moisture in them (the so called popcorn effect). For details, refer to the Drypack information in the *“Data Handbook IC26; Integrated Circuit Packages; Section: Packing Methods”*.
2. These packages are not suitable for wave soldering as a solder joint between the printed-circuit board and heatsink (at bottom version) can not be achieved, and as solder may stick to the heatsink (on top version).
3. If wave soldering is considered, then the package must be placed at a 45° angle to the solder wave direction. The package footprint must incorporate solder thieves downstream and at the side corners.
4. Wave soldering is only suitable for LQFP, TQFP and QFP packages with a pitch (e) equal to or larger than 0.8 mm; it is definitely not suitable for packages with a pitch (e) equal to or smaller than 0.65 mm.
5. Wave soldering is only suitable for SSOP and TSSOP packages with a pitch (e) equal to or larger than 0.65 mm; it is definitely not suitable for packages with a pitch (e) equal to or smaller than 0.5 mm.

Bluetooth Adapter IC

PCF26100

14 DATA SHEET STATUS

DATA SHEET STATUS ⁽¹⁾	PRODUCT STATUS ⁽²⁾	DEFINITIONS
Objective data	Development	This data sheet contains data from the objective specification for product development. Philips Semiconductors reserves the right to change the specification in any manner without notice.
Preliminary data	Qualification	This data sheet contains data from the preliminary specification. Supplementary data will be published at a later date. Philips Semiconductors reserves the right to change the specification without notice, in order to improve the design and supply the best possible product.
Product data	Production	This data sheet contains data from the product specification. Philips Semiconductors reserves the right to make changes at any time in order to improve the design, manufacturing and supply. Changes will be communicated according to the Customer Product/Process Change Notification (CPCN) procedure SNW-SQ-650A.

Notes

1. Please consult the most recently issued data sheet before initiating or completing a design.
2. The product status of the device(s) described in this data sheet may have changed since this data sheet was published. The latest information is available on the Internet at URL <http://www.semiconductors.philips.com>.

15 DEFINITIONS

Short-form specification — The data in a short-form specification is extracted from a full data sheet with the same type number and title. For detailed information see the relevant data sheet or data handbook.

Limiting values definition — Limiting values given are in accordance with the Absolute Maximum Rating System (IEC 60134). Stress above one or more of the limiting values may cause permanent damage to the device. These are stress ratings only and operation of the device at these or at any other conditions above those given in the Characteristics sections of the specification is not implied. Exposure to limiting values for extended periods may affect device reliability.

Application information — Applications that are described herein for any of these products are for illustrative purposes only. Philips Semiconductors make no representation or warranty that such applications will be suitable for the specified use without further testing or modification.

16 DISCLAIMERS

Life support applications — These products are not designed for use in life support appliances, devices, or systems where malfunction of these products can reasonably be expected to result in personal injury. Philips Semiconductors customers using or selling these products for use in such applications do so at their own risk and agree to fully indemnify Philips Semiconductors for any damages resulting from such application.

Right to make changes — Philips Semiconductors reserves the right to make changes, without notice, in the products, including circuits, standard cells, and/or software, described or contained herein in order to improve design and/or performance. Philips Semiconductors assumes no responsibility or liability for the use of any of these products, conveys no licence or title under any patent, copyright, or mask work right to these products, and makes no representations or warranties that these products are free from patent, copyright, or mask work right infringement, unless otherwise specified.

Philips Semiconductors – a worldwide company

Argentina: see South America

Australia: 3 Figtree Drive, HOMEBUSH, NSW 2140,
Tel. +61 2 9704 8141, Fax. +61 2 9704 8139

Austria: Computerstr. 6, A-1101 WIEN, P.O. Box 213,
Tel. +43 1 60 101 1248, Fax. +43 1 60 101 1210

Belarus: Hotel Minsk Business Center, Bld. 3, r. 1211, Volodarski Str. 6,
220050 MINSK, Tel. +375 172 20 0733, Fax. +375 172 20 0773

Belgium: see The Netherlands

Brazil: see South America

Bulgaria: Philips Bulgaria Ltd., Energoproject, 15th floor,
51 James Bourchier Blvd., 1407 SOFIA,
Tel. +359 2 68 9211, Fax. +359 2 68 9102

Canada: PHILIPS SEMICONDUCTORS/COMPONENTS,
Tel. +1 800 234 7381, Fax. +1 800 943 0087

China/Hong Kong: 501 Hong Kong Industrial Technology Centre,
72 Tat Chee Avenue, Kowloon Tong, HONG KONG,
Tel. +852 2319 7888, Fax. +852 2319 7700

Colombia: see South America

Czech Republic: see Austria

Denmark: Sydhavnsgade 23, 1780 COPENHAGEN V,
Tel. +45 33 29 3333, Fax. +45 33 29 3905

Finland: Sinikalliontie 3, FIN-02630 ESPOO,
Tel. +358 9 615 800, Fax. +358 9 6158 0920

France: 7 - 9 Rue du Mont Valérien, BP317, 92156 SURESNES Cedex,
Tel. +33 1 4728 6600, Fax. +33 1 4728 6638

Germany: Hammerbrookstraße 69, D-20097 HAMBURG,
Tel. +49 40 2353 60, Fax. +49 40 2353 6300

Hungary: Philips Hungary Ltd., H-1119 Budapest, Fehervari ut 84/A,
Tel: +36 1 382 1700, Fax: +36 1 382 1800

India: Philips INDIA Ltd, Band Box Building, 2nd floor,
254-D, Dr. Annie Besant Road, Worli, MUMBAI 400 025,
Tel. +91 22 493 8541, Fax. +91 22 493 0966

Indonesia: PT Philips Development Corporation, Semiconductors Division,
Gedung Philips, Jl. Buncit Raya Kav.99-100, JAKARTA 12510,
Tel. +62 21 794 0040 ext. 2501, Fax. +62 21 794 0080

Ireland: Newstead, Clonskeagh, DUBLIN 14,
Tel. +353 1 7640 000, Fax. +353 1 7640 200

Israel: RAPAC Electronics, 7 Kehilat Saloniki St, PO Box 18053,
TEL AVIV 61180, Tel. +972 3 645 0444, Fax. +972 3 649 1007

Italy: PHILIPS SEMICONDUCTORS, Via Casati, 23 - 20052 MONZA (MI),
Tel. +39 039 203 6838, Fax +39 039 203 6800

Japan: Philips Bldg 13-37, Kohnan 2-chome, Minato-ku,
TOKYO 108-8507, Tel. +81 3 3740 5130, Fax. +81 3 3740 5057

Korea: Philips House, 260-199 Itaewon-dong, Yongsan-ku, SEOUL,
Tel. +82 2 709 1412, Fax. +82 2 709 1415

Malaysia: No. 76 Jalan Universiti, 46200 PETALING JAYA, SELANGOR,
Tel. +60 3 750 5214, Fax. +60 3 757 4880

Mexico: 5900 Gateway East, Suite 200, EL PASO, TEXAS 79905,
Tel. +9-5 800 234 7381, Fax +9-5 800 943 0087

Middle East: see Italy

Netherlands: Postbus 90050, 5600 PB EINDHOVEN, Bldg. VB,
Tel. +31 40 27 82785, Fax. +31 40 27 88399

New Zealand: 2 Wagener Place, C.P.O. Box 1041, AUCKLAND,
Tel. +64 9 849 4160, Fax. +64 9 849 7811

Norway: Box 1, Manglerud 0612, OSLO,
Tel. +47 22 74 8000, Fax. +47 22 74 8341

Pakistan: see Singapore

Philippines: Philips Semiconductors Philippines Inc.,
106 Valero St. Salcedo Village, P.O. Box 2108 MCC, MAKATI,
Metro MANILA, Tel. +63 2 816 6380, Fax. +63 2 817 3474

Poland: Al.Jerozolimskie 195 B, 02-222 WARSAW,
Tel. +48 22 5710 000, Fax. +48 22 5710 001

Portugal: see Spain

Romania: see Italy

Russia: Philips Russia, Ul. Usatcheva 35A, 119048 MOSCOW,
Tel. +7 095 755 6918, Fax. +7 095 755 6919

Singapore: Lorong 1, Toa Payoh, SINGAPORE 319762,
Tel. +65 350 2538, Fax. +65 251 6500

Slovakia: see Austria

Slovenia: see Italy

South Africa: S.A. PHILIPS Pty Ltd., 195-215 Main Road Martindale,
2092 JOHANNESBURG, P.O. Box 58088 Newville 2114,
Tel. +27 11 471 5401, Fax. +27 11 471 5398

South America: Al. Vicente Pinzon, 173, 6th floor,
04547-130 SÃO PAULO, SP, Brazil,
Tel. +55 11 821 2333, Fax. +55 11 821 2382

Spain: Balmes 22, 08007 BARCELONA,
Tel. +34 93 301 6312, Fax. +34 93 301 4107

Sweden: Kottbygatan 7, Akalla, S-16485 STOCKHOLM,
Tel. +46 8 5985 2000, Fax. +46 8 5985 2745

Switzerland: Allmendstrasse 140, CH-8027 ZÜRICH,
Tel. +41 1 488 2741 Fax. +41 1 488 3263

Taiwan: Philips Semiconductors, 5F, No. 96, Chien Kuo N. Rd., Sec. 1,
TAIPEI, Taiwan Tel. +886 2 2134 2451, Fax. +886 2 2134 2874

Thailand: PHILIPS ELECTRONICS (THAILAND) Ltd.,
60/14 MOO 11, Bangna Trad Road KM. 3, Bagna, BANGKOK 10260,
Tel. +66 2 361 7910, Fax. +66 2 398 3447

Turkey: Yukari Dudullu, Org. San. Blg., 2.Cad. Nr. 28 81260 Umraniye,
ISTANBUL, Tel. +90 216 522 1500, Fax. +90 216 522 1813

Ukraine: PHILIPS UKRAINE, 4 Patrice Lumumba str., Building B, Floor 7,
252042 KIEV, Tel. +380 44 264 2776, Fax. +380 44 268 0461

United Kingdom: Philips Semiconductors Ltd., 276 Bath Road, Hayes,
MIDDLESEX UB3 5BX, Tel. +44 208 730 5000, Fax. +44 208 754 8421

United States: 811 East Arques Avenue, SUNNYVALE, CA 94088-3409,
Tel. +1 800 234 7381, Fax. +1 800 943 0087

Uruguay: see South America

Vietnam: see Singapore

Yugoslavia: PHILIPS, Trg N. Pasica 5/v, 11000 BEOGRAD,
Tel. +381 11 3341 299, Fax.+381 11 3342 553

For all other countries apply to: Philips Semiconductors,
Marketing Communications, Building BE-p, P.O. Box 218, 5600 MD EINDHOVEN,
The Netherlands, Fax. +31 40 27 24825

Internet: <http://www.semiconductors.philips.com>

© Philips Electronics N.V. 2001

SCA 72

All rights are reserved. Reproduction in whole or in part is prohibited without the prior written consent of the copyright owner.

The information presented in this document does not form part of any quotation or contract, is believed to be accurate and reliable and may be changed without notice. No liability will be accepted by the publisher for any consequence of its use. Publication thereof does not convey nor imply any license under patent- or other industrial or intellectual property rights.

Printed in The Netherlands

403506/01/pp28

Date of release: 2001 Jun 19

Document order number: 9397 750 08036

Let's make things better.

Philips
Semiconductors



PHILIPS