



# TIGER ELECTRONIC CO.,LTD

## TO-92 Plastic-Encapsulate Transistors

**2SC945** TRANSISTOR (NPN )

### FEATURE

- Excellent  $h_{FE}$  linearity
- Low noise
- Complementary to A733

### MAXIMUM RATINGS ( $T_a=25^\circ\text{C}$ unless otherwise noted)

Symbol	Parameter	Value	Unit
$V_{CB0}$	Collector-Base Voltage	60	V
$V_{CE0}$	Collector-Emitter Voltage	50	V
$V_{EB0}$	Emitter-Base Voltage	5	V
$I_C$	Collector Current -Continuous	150	mA
$P_C$	Collector Power Dissipation	400	mW
$T_J$	Junction Temperature	125	$^\circ\text{C}$
$T_{stg}$	Storage Temperature	-55-125	$^\circ\text{C}$

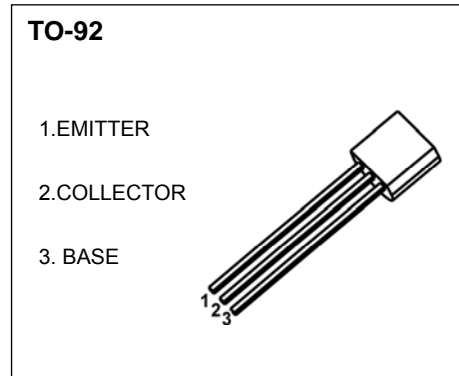

### ELECTRICAL CHARACTERISTICS ( $T_a=25^\circ\text{C}$ unless otherwise specified)

Parameter	Symbol	Test conditions	Min	Typ	Max	Unit
Collector-base breakdown voltage	$V_{(BR)CBO}$	$I_C=1\text{mA}, I_E=0$	60			V
Collector-emitter breakdown voltage	$V_{(BR)CEO}$	$I_C=100\mu\text{A}, I_B=0$	50			V
Emitter-base breakdown voltage	$V_{(BR)EBO}$	$I_E=100\mu\text{A}, I_C=0$	5			V
Collector cut-off current	$I_{CBO}$	$V_{CB}=60\text{V}, I_E=0$			0.1	$\mu\text{A}$
Collector cut-off current	$I_{CEO}$	$V_{CE}=45\text{V}, I_B=0$			0.1	$\mu\text{A}$
Emitter cut-off current	$I_{EBO}$	$V_{EB}=5\text{V}, I_C=0$			0.1	$\mu\text{A}$
DC current gain	$h_{FE(1)}$	$V_{CE}=6\text{V}, I_C=1\text{mA}$	70		700	
	$h_{FE(2)}$	$V_{CE}=6\text{V}, I_C=0.1\text{mA}$	40			
Collector-emitter saturation voltage	$V_{CE(sat)}$	$I_C=100\text{mA}, I_B=10\text{mA}$			0.3	V
Base-emitter saturation voltage	$V_{BE(sat)}$	$I_C=100\text{mA}, I_B=10\text{mA}$			1	V
Transition frequency	$f_T$	$V_{CE}=6\text{V}, I_C=10\text{mA}, f=30\text{MHz}$	200			MHz
Collector output capacitance	$C_{ob}$	$V_{CB}=10\text{V}, I_E=0, f=1\text{MHz}$			3.0	pF
Noise figure	NF	$V_{CE}=6\text{V}, I_C=0.1\text{mA}$ $R_G=10\text{k}\Omega, f=1\text{MHz}$			10	dB

### CLASSIFICATION OF $h_{FE(1)}$

Rank	O	Y	GR	BL
Range	70-140	120-240	200-400	350-700