

CCD image sensor S9037/S9038 series

High-speed operation, back-thinned FFT-CCD

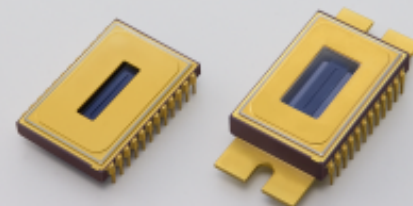

S9037/S9038 series FFT-CCD image sensors were developed for high-speed line scan cameras. Since an on-chip amplifier having a wide bandwidth is used to an image sensor, a pixel rate of 10 MHz can be obtained. S9037/S9038 series image sensors also deliver a high line scan rate equivalent to interline CCD sensors when used in line binning operation mode, because they have an active area pixel format where the number of vertical pixels is less than the number of horizontal pixels. This makes S9037/S9038 series ideal for line scan cameras. S9037/S9038 series image sensors have a pixel size of $24 \times 24 \mu\text{m}$ and are available in pixel formats of 512×4 pixels and 1024×4 pixels. S9038 series has a one-stage thermoelectric cooler assembled in the same package allowing stable operation at cooled temperatures. Both S9037/S9038 series image sensors use a quartz glass window equivalent to SUPRASIL glass that provides high transmittance even at 193 nm wavelength. These image sensors also have stable quantum efficiency in the UV region making them ideal for excimer laser monitors.

Features

- High-speed operation: 10 MHz
- Pixel size: $24 \times 24 \mu\text{m}$
- Line/pixel binning operation
- S9038 series: one-stage thermoelectric cooling
- High quantum efficiency: 90 % or more at peak
- MPP operation

Applications

- Excimer laser monitors
- High-speed line scan cameras

■ Selection guide

Type No.	Cooling	Number of total pixels	Number of active pixels	Active area [mm (H) × mm (V)]
S9037-0902	Non-cooled	520×6	512×4	12.288×0.096
S9037-1002		1044×8	1024×4	24.576×0.096
S9038-0902S	One-stage TE-cooled	520×6	512×4	12.288×0.096
S9038-1002S		1044×8	1024×4	24.576×0.096

■ Specifications

Parameter	S9037-0902	S9037-1002	S9038-0902S	S9038-1002S
Line rate	16 kHz	8 kHz	16 kHz	8 kHz
Data rate	10 MHz			
Vertical clock	2 phases			
Horizontal clock	2 phases			
Output circuit	Two-stage MOSFET source follower			
Package	24 pin metal package			
Window material *1	Quartz window equivalent to SUPRASIL		AR-coated sapphire	

*1: Window-less type is available as option.

CCD image sensor S9037/S9038 series

■ Absolute maximum ratings (Ta=25 °C)

Parameter	Symbol	Min.	Typ.	Max.	Unit
Operating temperature	Topr	-50	-	+70	°C
Storage temperature	Tstg	-50	-	+70	°C
OD voltage	VOD	-0.5	-	+25	V
RD voltage	VRD	-0.5	-	+18	V
ISH voltage	VISH	-0.5	-	+18	V
IGH voltage	VIG1H, VIG2H	-10	-	+15	V
SG voltage	VSG	-10	-	+15	V
OG voltage	VOG	-10	-	+15	V
RG voltage	VRG	-10	-	+15	V
TG voltage	VTG	-10	-	+15	V
Vertical clock voltage	VP1V, VP2V	-10	-	+15	V
Horizontal clock voltage	VP1H, VP2H	-10	-	+15	V

■ Operating conditions (MPP mode, Ta=25 °C)

Parameter	Symbol	Min.	Typ.	Max.	Unit	
Output transistor drain voltage	VOD	12	15	-	V	
Reset drain voltage	VRD	11.5	12	12.5	V	
Output gate voltage	VOG	1	3	5	V	
Substrate voltage	VSS	-	0	-	V	
Test point (horizontal input source)	VISH	-	VRD	-	V	
Test point (horizontal input gate)	VIG1H, VIG2H	-8	0	-	V	
Vertical shift register clock voltage	High	VP1VH, VP2VH	4	6	8	V
	Low	VP1VL, VP2VL	-9	-8	-7	
Horizontal shift register clock voltage	High	VP1HH, VP2HH	4	6	8	V
	Low	VP1HL, VP2HL	-9	-8	-7	
Summing gate voltage	High	VSGH	4	6	8	V
	Low	VSGL	-9	-8	-7	
Reset gate voltage	High	VRGH	4	6	8	V
	Low	VRGL	-9	-8	-7	
Transfer gate voltage	High	VTGH	4	6	8	V
	Low	VTGL	-9	-8	-7	

■ Electrical characteristics (Ta=25 °C)

Parameter	Symbol	Remark	Min.	Typ.	Max.	Unit
Signal output frequency	fc	-	-	-	10	MHz
Reset clock frequency	frg	-	-	-	10	MHz
Vertical shift register capacitance	-0902	CP1V, CP2V	-	300	-	pF
	-1002		-	500	-	pF
Horizontal shift register capacitance	-0902	CP1H, CP2H	-	200	-	pF
	-1002		-	300	-	pF
Summing gate capacitance	C _{SG}	-	-	7	-	pF
Reset gate capacitance	C _{RG}	-	-	7	-	pF
Transfer gate capacitance	C _{TG}	-	-	15	-	pF
Transfer efficiency	CTE	*2	-	0.99995	-	-
DC output level	V _{out}	-	-	7	-	V
Output impedance	Z _o	*3	-	500	-	Ω
Power dissipation	P	*3, *4	-	100	-	mW

*2: Charge transfer efficiency per pixel, measured at half of the full well capacity.

*3: This depends on the output transistor drain voltage.

*4: Power dissipation of the on-chip amplifier.

■ Electrical and optical characteristics (Ta=25 °C, unless otherwise noted)

Parameter	Symbol	Min.	Typ.	Max.	Unit
Saturation output voltage	Vsat		Fw × Sv		V
Full well capacity	Vertical	-	300	-	ke ⁻
	Horizontal (summing)	-	600	-	
CCD node sensitivity	Sv	-	1.2	-	μV/e ⁻
Dark current *5 (MPP mode)	25 °C	-	4,000	-	e ⁻ /pixel/s
	0 °C	-	200	-	
Readout noise *6	Nr	-	100	-	e ⁻ rms
Dynamic range (line binning)	DR	-	6000	-	-
Photo response non-uniformity *7	PRNU	-	-	±10	%
Spectral response range (without window)	λ	-	200 to 1100	-	nm

*5: Dark current nearly doubles for every 5 to 7 °C increase in temperature.

*6: -40 °C, operating frequency is 80 kHz.

*7: Condition: half of saturation output voltage.

■ Spectral response (without window) *8

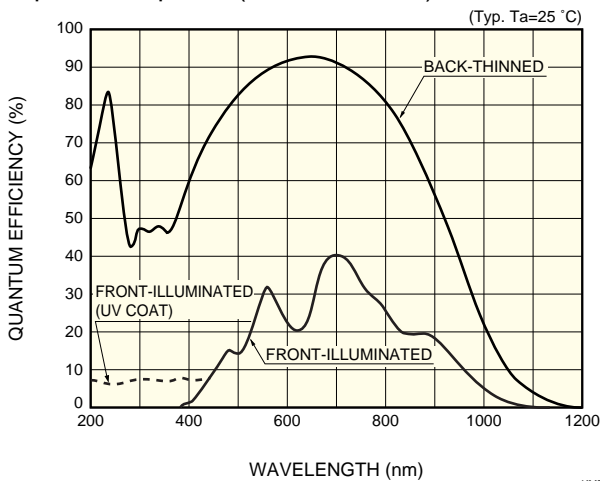

■ Spectral transmittance characteristics

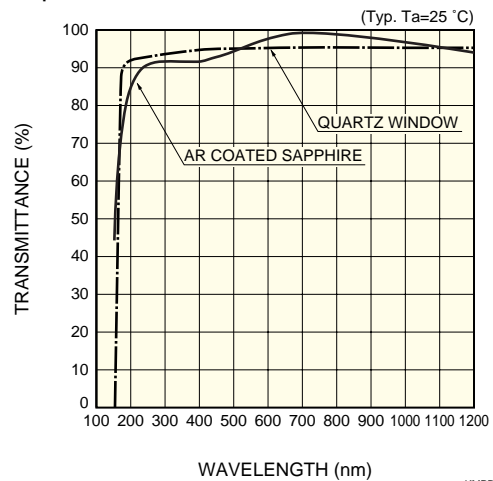

*8: Spectral response with quartz glass or AR-coated sapphire are decreased by the transmittance.

■ Spectral response of photosensitive surface (without cap)

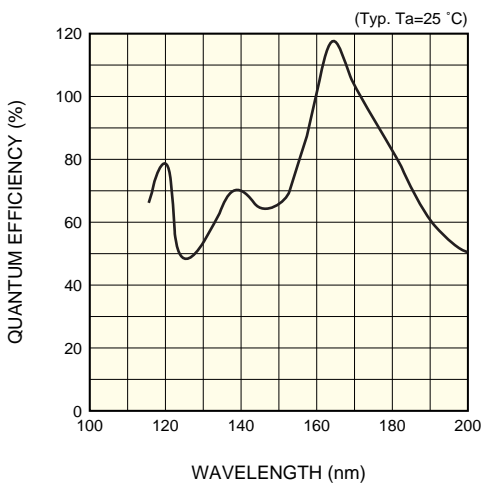

■ Dark current vs. temperature

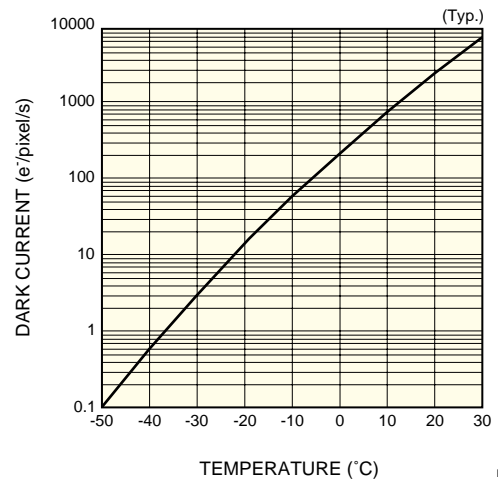

CCD image sensor S9037/S9038 series

■ Device structure

S9037-0902, S9038-0902S

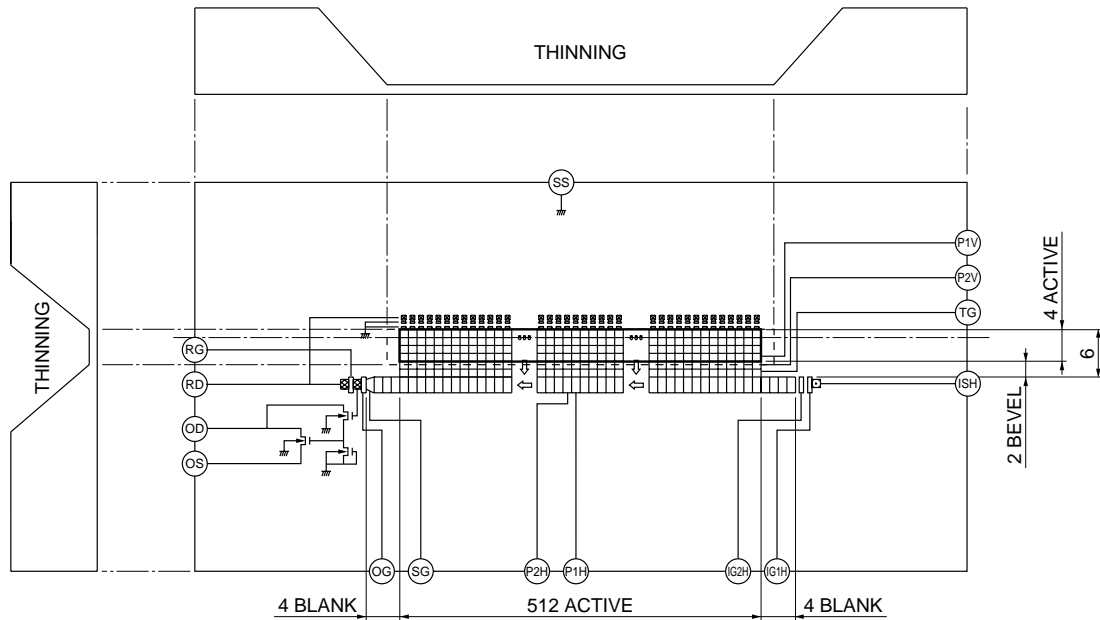

KMPDC0159EC

S9037-1002, S9038-1002S

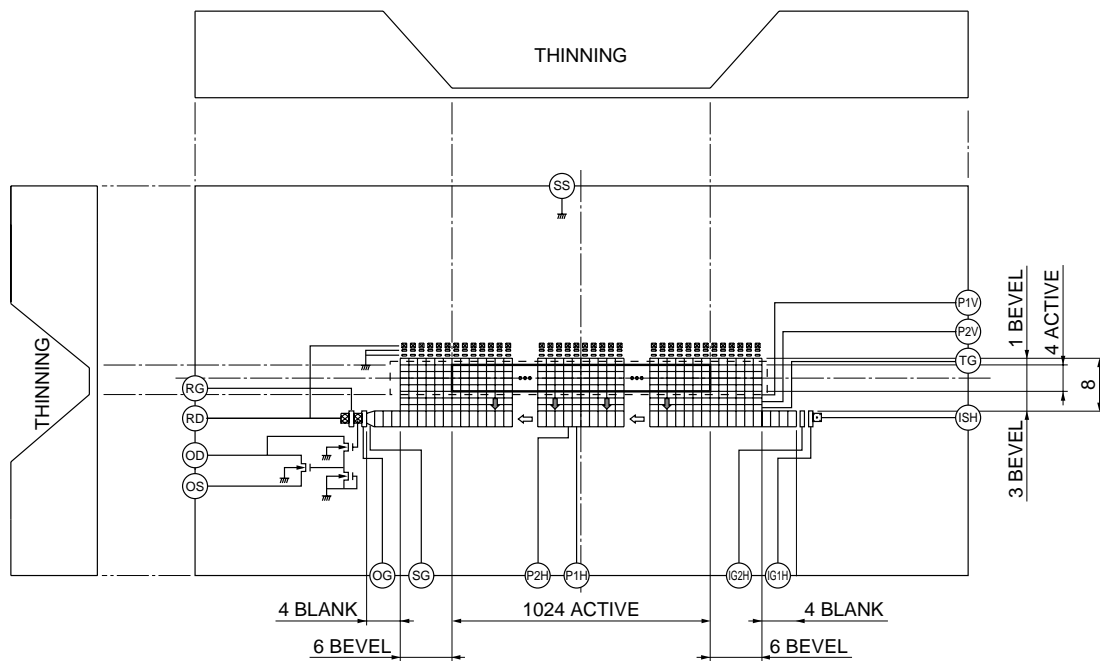

KMPDC0160EB

■ Timing chart (line binning)

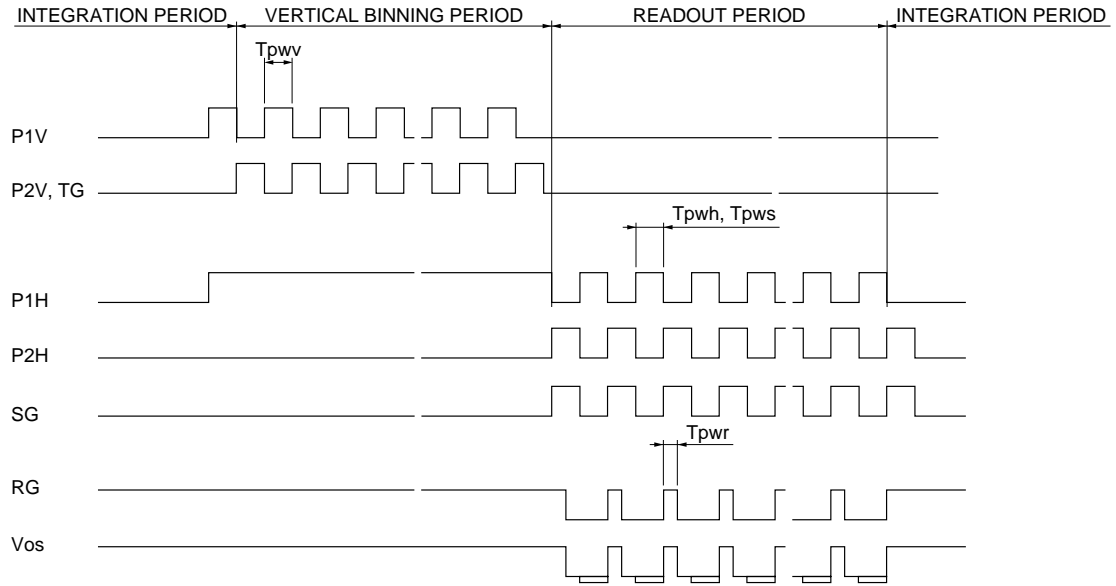

KMPDC0161EA

Parameter		Symbol	Min.	Typ.	Max.	Unit
P1V, P2V, TG	Pulse width	Tpwv	1	-	-	μs
	Rise and fall time	Tprv, Tpfv	-	20	-	ns
P1H, P2H	Pulse width	Tpwh	50	-	-	ns
	Rise and fall time	Tprh, Tpfh	-	10	-	ns
	Duty ratio	-	-	50	-	%
SG	Pulse width	Tpsr	50	-	-	ns
	Rise and fall time	Tprs, Tpfs	-	10	-	ns
	Duty ratio	-	-	50	-	%
RG	Pulse width	Tpr	-	15	-	ns
	Rise and fall time	Tpr, Tprf	5	-	-	ns
TG (P2V) - P1H	Overlap time	Tovr	3	-	-	μs

CCD image sensor S9037/S9038 series

Dimensional outlines (unit: mm)

S9037-0902

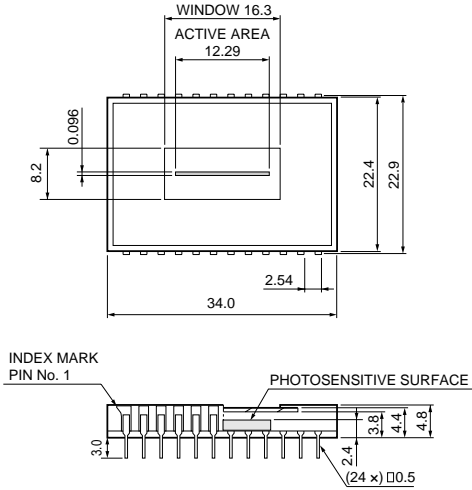

KMPDA0153EB

S9037-1002

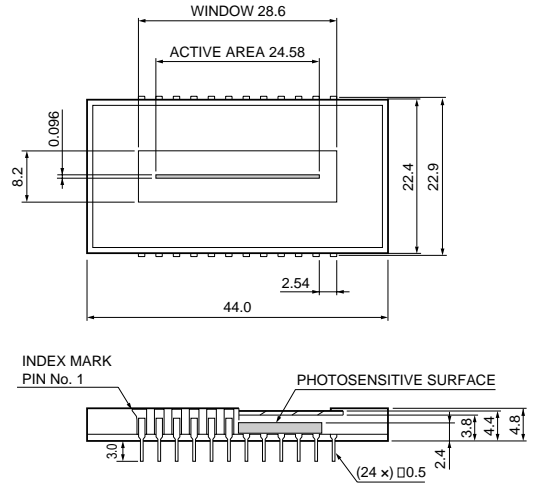

KMPDA0154EA

S9038-0902S

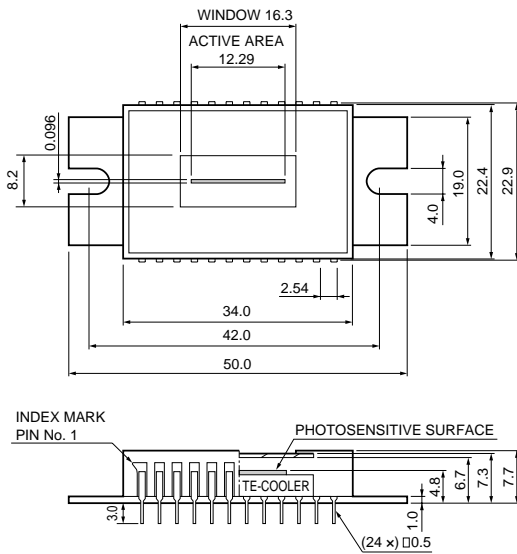

KMPDA0155EA

S9038-1002S

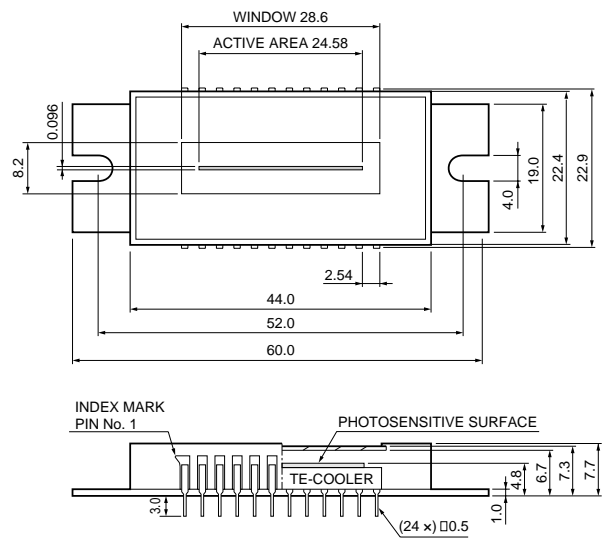

KMPDA0156EA

CCD image sensor S9037/S9038 series

Dimensional outlines of windowless types (unit: mm)

S9037-0902N

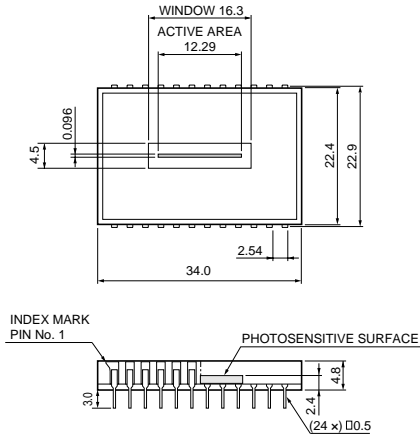

KMPDA0165EA

S9037-1002N

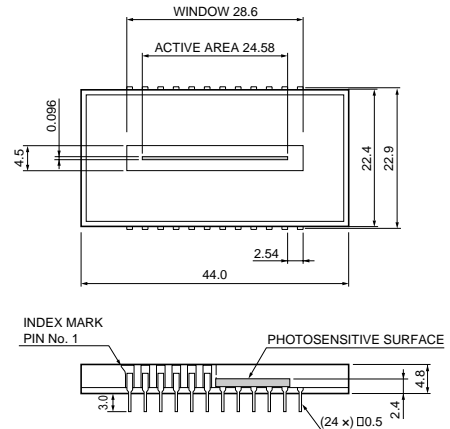

KMPDA0166EA

S9038-0902N

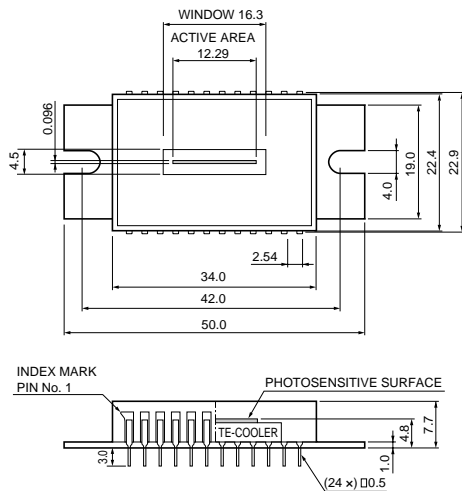

KMPDA0167EA

S9038-1002N

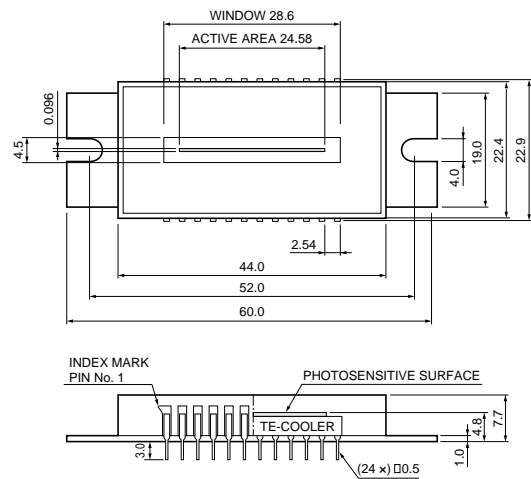

KMPDA0168EA

Pin connections

Pin No.	S9037 series			S9038 series		
	Sym bol	Description	Remark	Sym bol	Description	Remark
1	RD	Reset drain	+12 V	RD	Reset drain	+12 V
2	OS	Output transistor source	External R2=2.2 kΩ	OS	Output transistor source	External RL=2.2 kΩ
3	OD	Output transistor drain	+15 V	OD	Output transistor drain	+15 V
4	OG	Output gate	+3 V	OG	Output gate	+3 V
5	SG	Summing gate	Same timing as P2H	SG	Summing gate	Same timing as P2H
6	-			-		
7	-			-		
8	P2H	CCD horizontal register clock-2		P2H	CCD horizontal register clock-2	
9	P1H	CCD horizontal register clock-1		P1H	CCD horizontal register clock-1	
10	IG2H	Test point (horizontal input gate-2)	GND	IG2H	Test point (horizontal input gate-2)	GND
11	IG1H	Test point (horizontal input gate-1)	GND	IG1H	Test point (horizontal input gate-1)	GND
12	ISH	Test point (horizontal input source)	Shorted to RD	ISH	Test point (horizontal input source)	Shorted to RD
13	TG	Transfer gate	Same timing as P2V	TG	Transfer gate	Same timing as P2V
14	P2V	CCD vertical register clock-2		P2V	CCD vertical register clock-2	
15	P1V	CCD vertical register clock-1		P1V	CCD vertical register clock-1	
16	NC			Th1	Thermistor	
17	NC			Th2	Thermistor	
18	NC			P-	TE-cooler-	
19	NC			P+	TE-cooler+	
20	SS	Substrate (GND)	GND	SS	Substrate (GND)	
21	NC			NC		
22	NC			NC		
23	NC			NC		
24	RG	Reset gate		RG	Reset gate	

■ Specifications of built-in TE-cooler (Typ.)

Parameter	Symbol	Condition	S9038-0902	S9038-1002	Unit
Internal resistance	R _{int}	T _a =25 °C	2.5	1.2	Ω
Maximum current *8	I _{max}	T _c *9=Th *10=25 °C	1.5	3.0	A
Maximum voltage	V _{max}	T _c *9=Th *10=25 °C	3.8	3.6	V
Maximum heat absorption *11	Q _{max}		3.4	5.1	W
Maximum temperature of heat radiating side	-		70	70	°C

*8: Maximum current I_{max}:

If the current greater than this value flows into the thermoelectric cooler, the heat absorption begins to decrease due to the Joule heat. It should be noted that this value is not the damage threshold value. To protect the thermoelectric cooler and maintain stable operation, the supply current should be less than 60 % of this maximum current.

*9: Temperature of the cooling side of thermoelectric cooler.

*10: Temperature of the heat radiating side of thermoelectric cooler.

*11: Maximum heat absorption Q_{max}.

This is a theoretical heat absorption level that offsets the temperature difference in the thermoelectric cooler when the maximum current is supplied to the unit.

S9038-0902S

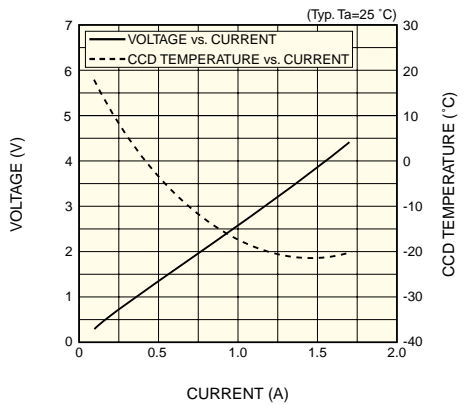

S9038-1002S

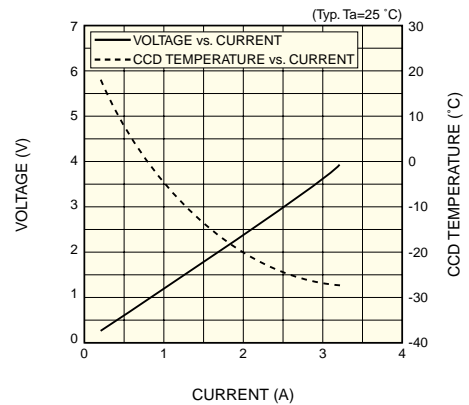

■ Specifications of built-in temperature sensor

A chip thermistor is built in the same package with a CCD chip, and the CCD chip temperature can be monitored with it. A relation between the thermistor resistance and absolute temperature is expressed by the following equation.

$$R_1 = R_2 \times \exp\left(\frac{B}{T_1} - \frac{B}{T_2}\right)$$

where R₁ is the resistance at absolute temperature T₁ (K)

R₂ is the resistance at absolute temperature T₂ (K)

B is so-called the B constant (K)

The characteristics of the thermistor used are as follows.

$$R(298K) = 10 \text{ k}\Omega$$

$$B(298K / 323K) = 3450 \text{ K}$$

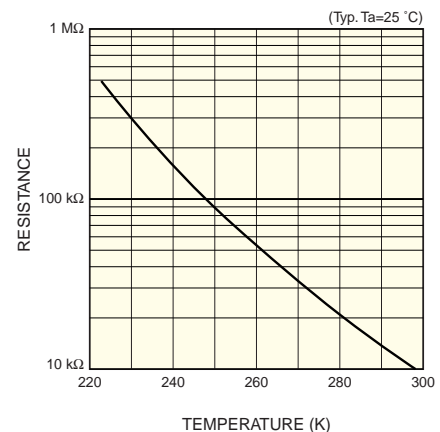

■ Precaution for use (Electrostatic countermeasures)

- Handle these sensors with bare hands or wearing cotton gloves. In addition, wear anti-static clothing and use a wrist band with an earth ring, in order to prevent electrostatic damage due to electrical charges from friction.
- Avoid directly placing these sensors on a work-desk or work-bench that may carry an electrostatic charge.
- Provide ground lines or ground connection with the work-floor, work-desk and work-bench to allow static electricity to discharge.
- Ground the tools used to handle these sensors, such as tweezers and soldering irons.

It is not always necessary to provide all the electrostatic measures stated above. Implement these measures according to the amount of damage that occurs.

■ Element cooling/heating temperature incline rate

Element cooling/heating temperature incline rate should be set at less than 5 K/min.