

Standard SCRs, 55A

Main Features

Symbol	Value	Unit
$I_{T(RMS)}$	55	A
V_{DRM}/V_{RRM}	600 to 1600	V
I_{GT}	80	mA

DESCRIPTION

The 55PT series of silicon controlled rectifiers are high performance glass passivated technology, and are suitable for general purpose applications, where power handling and power dissipation are critical, such as solid state relay, welding equipment and high power motor control.

Base on a clip assembly technology, they offer a superior performance in surge current capabilities.

Thanks to their internal ceramic pad, they provide high voltage insulation(2500V_{RMS}).

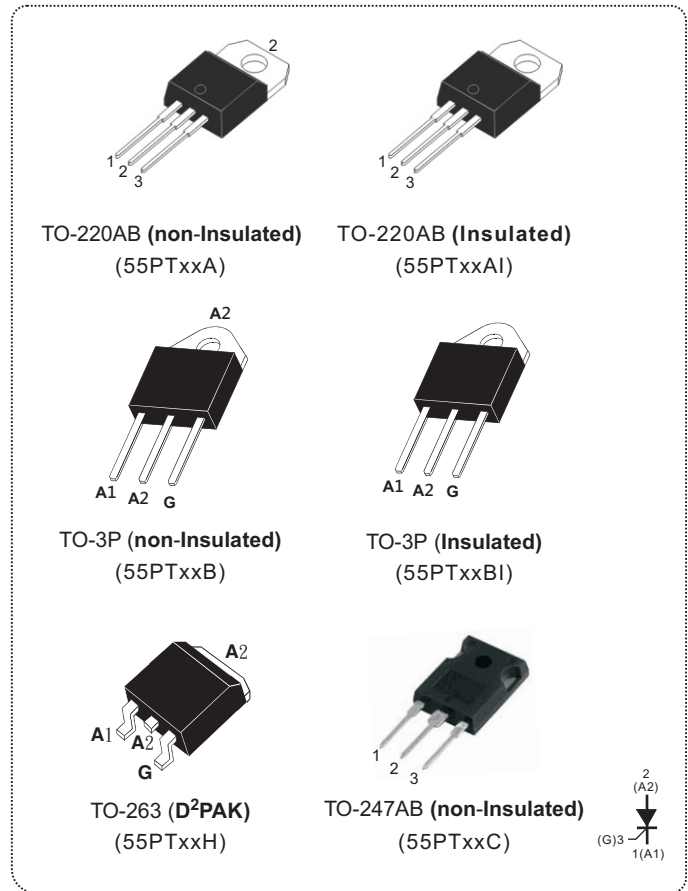

ABSOLUTE MAXIMUM RATINGS

PARAMETER	SYMBOL	TEST CONDITIONS		VALUE	UNIT
RMS on-state current full sine wave (180° conduction angle)	$I_{T(RMS)}$	TO-3P/TO-247AB	$T_c=85^\circ\text{C}$	55	A
		TO-220AB/TO-263	$T_c=80^\circ\text{C}$		
		TO-220AB insulated/TO-3P insulated	$T_c=70^\circ\text{C}$		
Average on-state current (180° conduction angle)	$I_{T(AV)}$	TO-3P/TO-247AB	$T_c=85^\circ\text{C}$	35	A
		TO-220AB/TO-263	$T_c=80^\circ\text{C}$		
		TO-220AB insulated/TO-3P insulated	$T_c=70^\circ\text{C}$		
Non repetitive surge peak on-state current (full cycle, T_j initial = 25°C)	I_{TSM}	F = 50 Hz	t = 20 ms	520	A
		F = 60 Hz	t = 16.7 ms	540	
I^2t Value for fusing	i^2t	$t_p = 10$ ms		1352	A ² s
Critical rate of rise of on-state current $V_D = 67\% V_{DRM}$, $t_p = 200\mu\text{s}$, $I_G = 0.3\text{A}$ $dI_G/dt = 0.3\text{A}/\mu\text{s}$	dI/dt	F = 60 Hz	$T_j = 125^\circ\text{C}$	150	A/ μs
Peak gate current	I_{GM}	$T_p = 20 \mu\text{s}$	$T_j = 125^\circ\text{C}$	5	A
Maximum gate power	P_{GM}	$T_p = 20\mu\text{s}$	$T_j = 125^\circ\text{C}$	10	W
Average gate power dissipation	$P_{G(AV)}$	$T_j = 125^\circ\text{C}$		2	W
Repetitive peak off-state voltage	V_{DRM}	$T_j = 125^\circ\text{C}$		600 to 1600	V
Repetitive peak reverse voltage	V_{RRM}				
Storage temperature range	T_{stg}			- 40 to + 150	°C
Operating junction temperature range	T_j			- 40 to + 125	
Maximum peak reverse gate voltage	V_{RGM}			5	V

ELECTRICAL SPECIFICATIONS (T _J = 25 °C unless otherwise specified)							
SYMBOL	TEST CONDITIONS		55PT06xx	55PT10xx	55PT16xx	Unit	
			55PT08xx	55PT12xx			
I _{GT}	V _D = 12V, R _L = 33Ω	Max.	30	40	80	mA	
V _{GT}		Max.	1.5			V	
V _{GD}	V _D = V _{DRM} , R _L = 3.3KΩ, R _{GK} = 220Ω	T _J = 125°C	Min.	0.2		V	
I _H	I _T = 500mA, Gate open		Max.	80	100	120	mA
I _L	I _G = 1.2×I _{GT}		Max.	100	130	150	mA
dV/dt	V _D = 67% V _{DRM} , Gate open	T _J = 125°C	Min.	700	1000	1000	V/μs
V _{TM}	I _T = 80A, t _p = 380μs	T _J = 25°C	Max.	1.6		V	
I _{DRM} I _{RPM}	V _D = V _{DRM} , V _R = V _{RPM} R _{GK} = 220Ω	T _J = 25°C	Max.	10		μA	
		T _J = 125°C	Max.	6		mA	
V _{to}	Threshold Voltage		T _J = 125°C	Max.	1.02		V
R _d	Dynamic Resistance		T _J = 125°C	Max.	85		mΩ

THERMAL RESISTANCE					
SYMBOL	Parameter			VALUE	UNIT
R _{th(j-c)}	Junction to case (DC)	D ² PAK/TO-220AB/TO-3P/TO-247AB		0.8	°C/W
		TO-220AB insulated/TO-3P insulated		0.9	
R _{th(j-a)}	Junction to ambient	S = 1 cm ²	TO-263(D ² PAK)	45	°C/W
			TO-220AB/TO-220AB insulated	60	
			TO-3P/TO-247AB/TO-3P insulated	50	

S=Copper surface under tab

PRODUCT SELECTOR							
PART NUMBER	VOLTAGE (xx)					SENSITIVITY	PACKAGE
	600 V	800 V	1000 V	1200 V	1600 V		
55PTxxA/55PTxxAI	V	V	V	V	V	80 mA	TO-220AB
55PTxxH	V	V	V	V	V	80 mA	D ² PAK
55PTxxB/55PTxxBI	V	V	V	V	V	80 mA	TO-3P
55PTxxC	V	V	V	V	V	80 mA	TO-247AB

ORDERING INFORMATION					
ORDERING TYPE	MARKING	PACKAGE	WEIGHT	BASE Q'TY	DELIVERY MODE
55PTxxA	55PTxxA	TO-220AB	2.0g	50	Tube
55PTxxAI	55PTxxAI	TO-220AB (insulated)	2.3g	50	Tube
55PTxxH	55PTxxH	TO-263(D ² PAK)	2.0g	50	Tube
55PTxxB	55PTxxB	TO-3P	4.3g	30	Tube
55PTxxBI	55PTxxBI	TO-3P insulated	4.8g	30	Tube
55PTxxC	55PTxxC	TO-247AB	5g	30	Tube

Note: xx = voltage

ORDERING INFORMATION SCHEME

55 PT 06 AI

Current

55 = 55A, $I_{T(RMS)}$

SCR series

Voltage Code

06 = 600V
 08 = 800V
 10 = 1000V
 12 = 1200V
 16 = 1600V

Package type

A = TO-220AB (non-insulated)
 AI = TO-220AB (insulated)
 B = TO-3P (non-insulated)
 BI = TO-3P (insulated)
 C = TO-247AB
 H = TO-263 (D²PAK)

Fig.1 Maximum power dissipation versus average on-state current (half cycle)

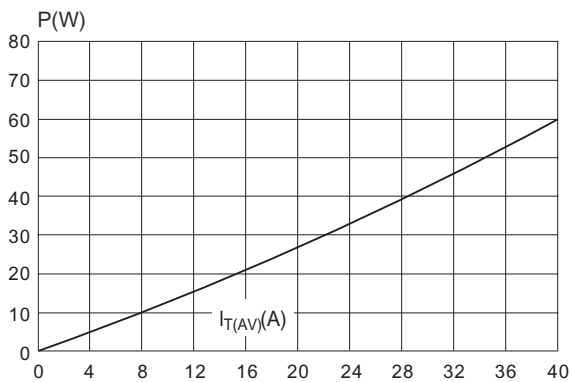

Fig.2 RMS on-state current versus case temperature (full cycle)

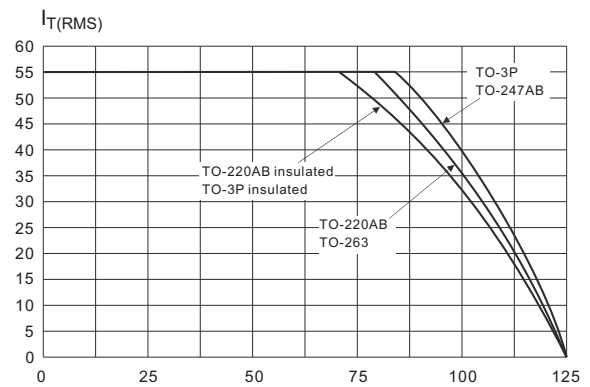

Fig.3 On-state characteristics (maximum values).

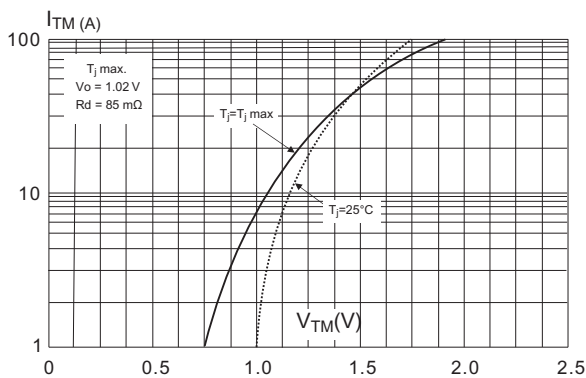

Fig.4 Surge peak on-state current versus number of cycles.

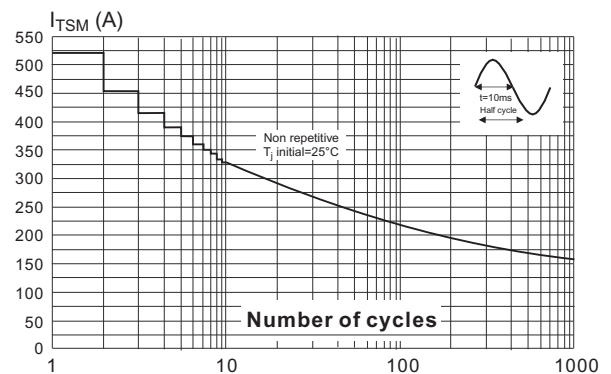

Fig.5 Non-repetitive surge peak on-state current for a sinusoidal pulse with width $t_p < 10$ ms, and corresponding value of I^2t .

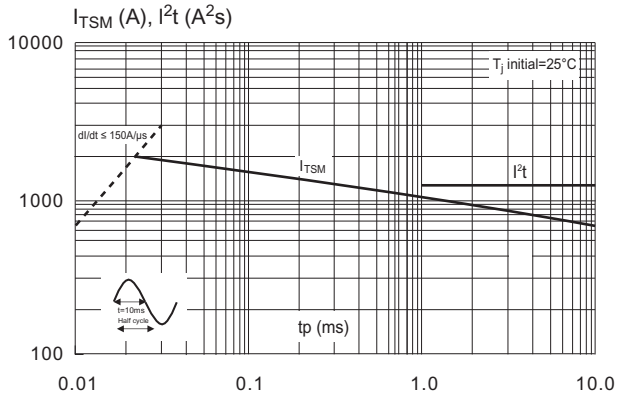
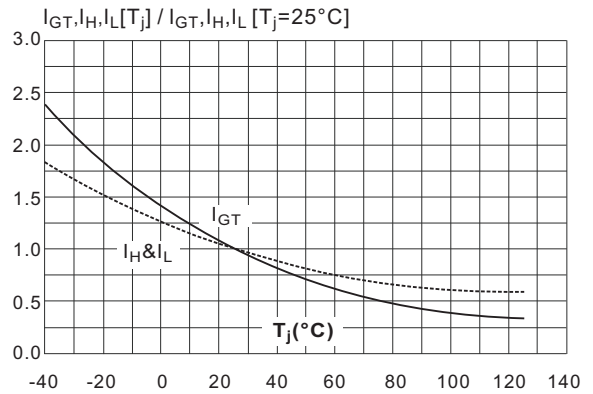
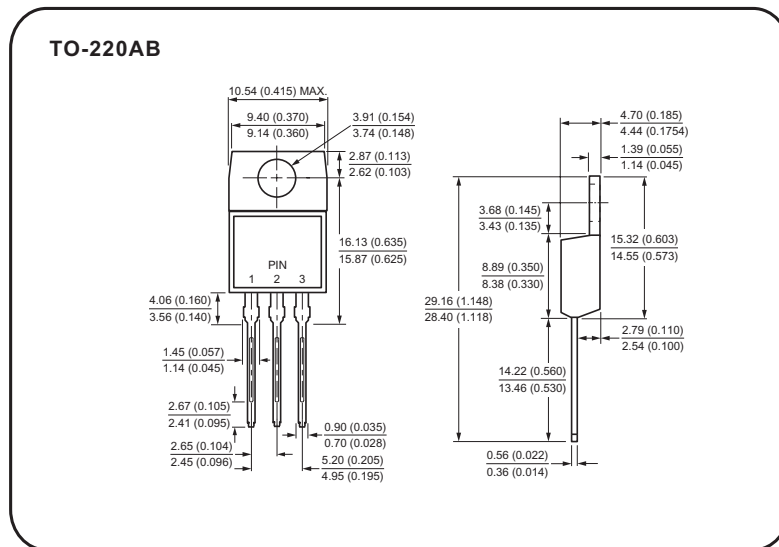

Fig.6 Relative variations of gate trigger current, holding current and latching current versus junction temperature (typical values)



Case Style



All dimensions in millimeters(inches)

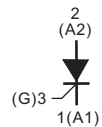

Case Style

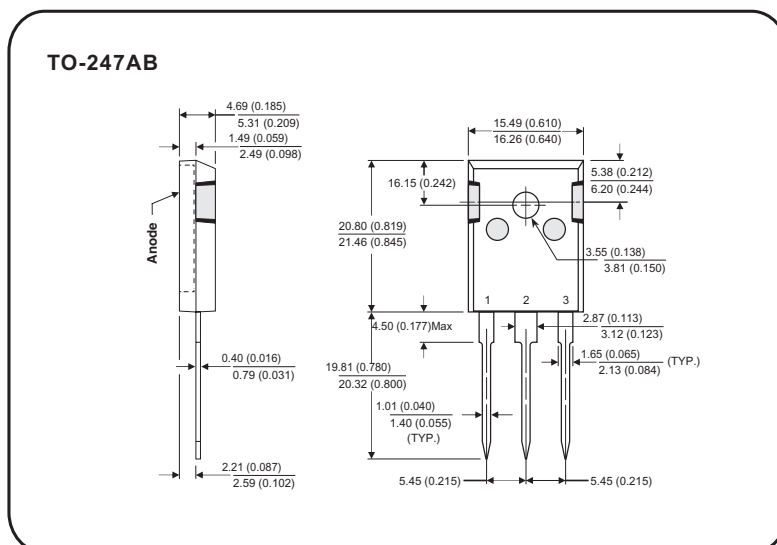
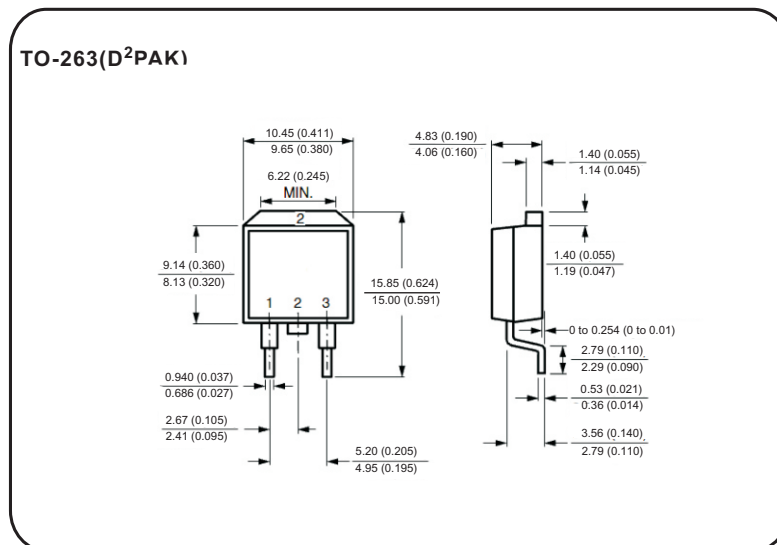
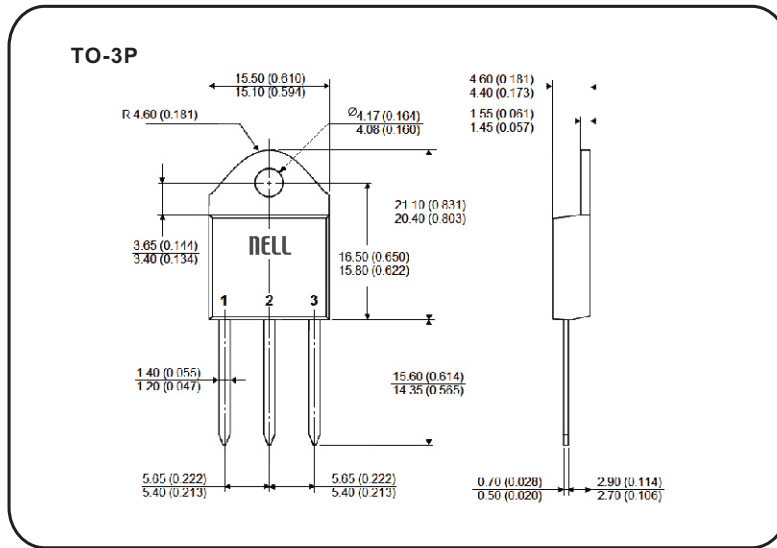

All dimensions in millimeters(inches)

