



Product Specification

AU OPTRONICS CORPORATION

() Preliminary Specifications

(V) Final Specifications

Module	17.3”(17.25”) FHD 16:9 Color TFT-LCD with LED Backlight design
Model Name	B173HW01 V0 (H/W:1A)
Note ()	<i>LED Backlight with driving circuit design</i>

Customer	Date
Checked & Approved by	Date
Note: This Specification is subject to change without notice.	

Approved by	Date
<u>Beyond Yang</u>	<u>07/09/2009</u>
Prepared by	
<u>YW LEE</u>	<u>07/09/2009</u>
NBBU Marketing Division AU Optronics corporation	



Contents

1. Handling Precautions 4

2. General Description..... 5

 2.1 General Specification 5

 2.2 Optical Characteristics..... 6

3. Functional Block Diagram..... 10

4. Absolute Maximum Ratings 11

 4.1 Absolute Ratings of TFT LCD Module..... 11

 4.2 Absolute Ratings of Environment 11

5. Electrical Characteristics 12

 5.1 TFT LCD Module 12

 5.2 Backlight Unit 14

6. Signal Interface Characteristic 15

 6.1 Pixel Format Image 15

 6.2 The Input Data Format..... 16

 6.3 Integration Interface Requirement 18

 6.4 Interface Timing 20

7. Panel Reliability Test..... 22

 7.1 Vibration Test..... 22

 7.2 Shock Test 22

 7.3 Reliability Test 22

8. Mechanical Characteristics 23

 8.1 LCM Outline Dimension 23

 8.2 Screw Hole Depth and Center Position..... 25

9. Shipping and Package 26

 9.1 Shipping Label Format 26

 9.2 Carton Package..... 27

 9.3 Shipping Package of Palletizing Sequence 27

10. Appendix: EDID Description 28



Product Specification

AU OPTRONICS CORPORATION

Record of Revision

Version and Date	Page	Old description	New Description	Remark
0.1 2009/02/24	All	First Edition for Customer		
0.2 2009/03/23	All	◆ New format ◆ EDID modify		
0.3 2009/04/14	6	Add R, G, B Color Coordinates		
1.0 2009/07/09	26, 28~31	Modify Label EDID		

1. Handling Precautions

- 1) Since front polarizer is easily damaged, pay attention not to scratch it.
- 2) Be sure to turn off power supply when inserting or disconnecting from input connector.
- 3) Wipe off water drop immediately. Long contact with water may cause discoloration or spots.
- 4) When the panel surface is soiled, wipe it with absorbent cotton or other soft cloth.
- 5) Since the panel is made of glass, it may break or crack if dropped or bumped on hard surface.
- 6) Since CMOS LSI is used in this module, take care of static electricity and insure human earth when handling.
- 7) Do not open nor modify the Module Assembly.
- 8) Do not press the reflector sheet at the back of the module to any directions.
- 9) At the insertion or removal of the Signal Interface Connector, be sure not to rotate nor tilt the Interface Connector of the TFT Module.
- 11) After installation of the TFT Module into an enclosure (Notebook PC Bezel, for example), do not twist nor bend the TFT Module even momentarily. At designing the enclosure, it should be taken into consideration that no bending/twisting forces are applied to the TFT Module from outside. – Otherwise the TFT Module may be damaged.
- 12) Small amount of materials having no flammability grade is used in the LCD module. The LCD module should be supplied by power complied with requirements of Limited Power Source (IEC60950 or UL1950), or be applied exemption.
- 13) Disconnecting power supply before handling LCD modules, it can prevent electric shock, DO NOT TOUCH the electrode parts, cables, connectors and LED circuit part of TFT module that a LED light bar build in as a light source of back light unit. It can prevent electrostatic breakdown.

2. General Description

B173HW01 V0 is a Color Active Matrix Liquid Crystal Display composed of a TFT LCD panel, a driver circuit, and LED backlight system. The screen format is intended to support the FHD 16:9 1920(H) x 1080(V) screen and 262k colors (RGB 6-bits data driver) with LED backlight driving circuit. All input signals are LVDS interface compatible.

B173HW01 V0 is designed for a display unit of notebook style personal computer and industrial machine.

2.1 General Specification

The following items are characteristics summary on the table at 25 °C condition:

Items	Unit	Specifications			
Screen Diagonal	[mm]	17.3W”(17.25)			
Active Area	[mm]	381.888 X 214.812			
Pixels H x V		1920x3(RGB) x1080			
Pixel Pitch	[mm]	0.1989X0.1989			
Pixel Format		R.G.B. Vertical Stripe			
Display Mode		Normally White			
White Luminance (I _{LED} =20mA) (Note: I _{LED} is LED current)	[cd/m ²]	300 typ. (5 points average) 270 min. (5 points average)			
Luminance Uniformity		1.25 max. (5 points)			
Contrast Ratio		500 typ			
Response Time	[ms]	8 typ / 16 Max			
Nominal Input Voltage VDD	[Volt]	+3.3 typ.			
Power Consumption	[Watt]	9.0 max. (Include Logic and Blu power)			
Weight	[Grams]	590 max.			
Physical Size Include bracket	[mm]		Min.	Typ.	Max.
		Length	397.6	398.1	398.6
		Width	232.3	232.8	233.3
		Thickness	---	---	6.0
Electrical Interface		2 channel LVDS			
Glass Thickness	[mm]	0.5			
Surface Treatment		Glare, Hardness 4H			
Support Color		262K colors (RGB 6-bit)			



Product Specification

AU OPTRONICS CORPORATION

Temperature Range Operating	[°C]	0 to +50
Storage (Non-Operating)	[°C]	-20 to +60
RoHS Compliance		RoHS Compliance

2.2 Optical Characteristics

The optical characteristics are measured under stable conditions at 25°C (Room Temperature) :

Item	Symbol	Conditions	Min.	Typ.	Max.	Unit	Note				
White Luminance I _{LED} =20mA		5 points average	270	300	---	cd/m ²	1, 4, 5.				
Viewing Angle	θ_R	Horizontal (Right) CR = 10 (Left)	60	70	---	degree	4, 9				
	θ_L		60	70	---						
	ϕ_H	Vertical (Upper) CR = 10 (Lower)	45	60	---						
	ϕ_L		50	60	---						
Luminance Uniformity	δ_{5P}	5 Points	---	---	1.25		1, 3, 4				
Contrast Ratio	CR		400	500	---			4, 6			
Cross talk	%		---	---	4			4, 7			
Response Time	T _{RT}	Rising + Falling	---	8	16	msec		4, 8			
Color / Chromaticity Coodinates	Red	Rx	CIE 1931	0.603	0.638	0.668		4			
		Ry		0.301	0.331	0.361					
	Green	Gx		0.272	0.302	0.332					
		Gy		0.581	0.611	0.641					
	Blue	Bx		0.118	0.148	0.178					
		By		0.027	0.057	0.087					
	White	Wx		0.283	0.313	0.343					
		Wy		0.299	0.329	0.359					
	NTSC	%			---	72			---		

Note 1: 5 points position (Ref: Active area)

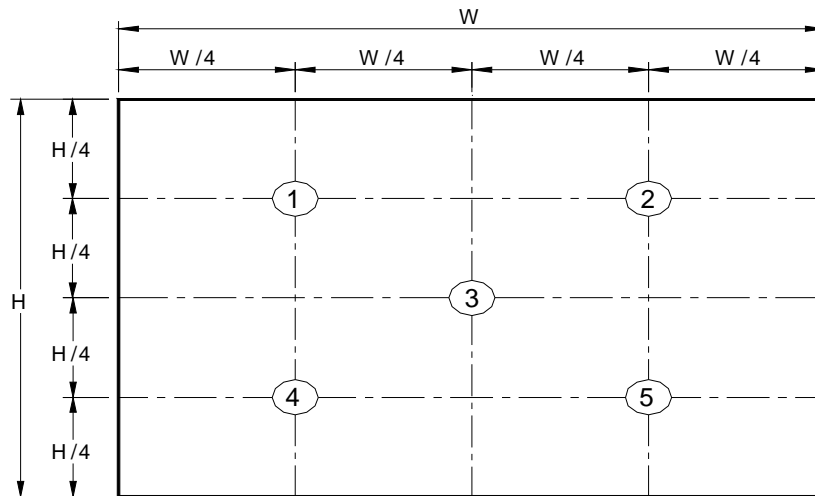

Note 2: The luminance uniformity of 5 points is defined by dividing the maximum luminance values by the minimum test point luminance

$$\delta_{w5} = \frac{\text{Maximum Brightness of five points}}{\text{Minimum Brightness of five points}}$$

Note 3: Measurement method

The LCD module should be stabilized at given temperature for 30 minutes to avoid abrupt temperature change during measuring. In order to stabilize the luminance, the measurement should be executed after lighting Backlight for 30 minutes in a stable, windless and dark room, and it should be measured in the center of screen.

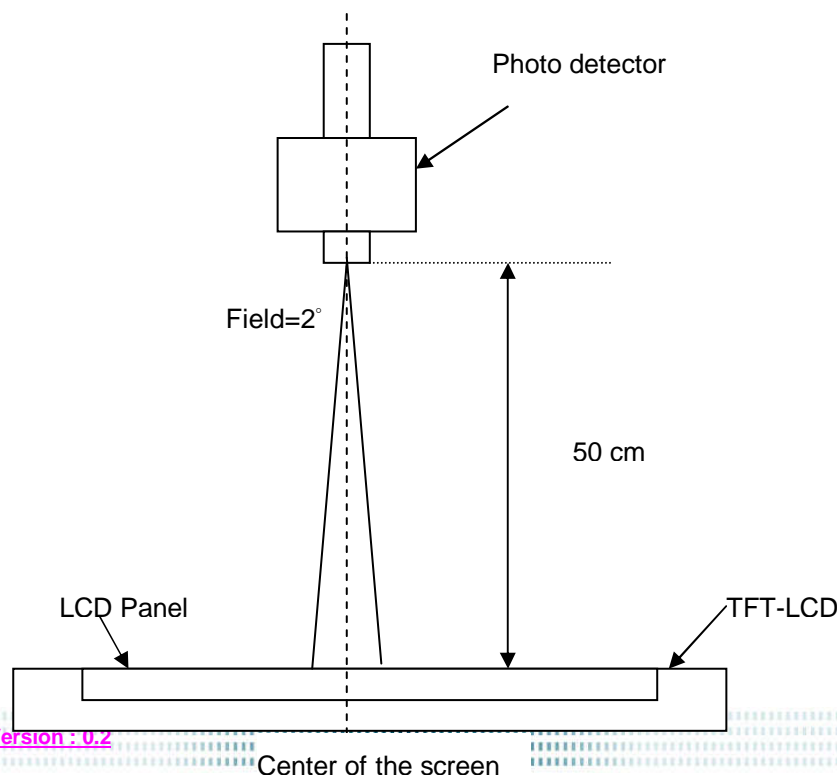

Note 4 : Definition of Average Luminance of White (Y_L):

Measure the luminance of gray level 63 at 5 points · $Y_L = [L(1) + L(2) + L(3) + L(4) + L(5)] / 5$

$L(x)$ is corresponding to the luminance of the point X at Figure in Note (1).

Note 5 : Definition of contrast ratio:

Contrast ratio is calculated with the following formula.

$$\text{Contrast ratio (CR)} = \frac{\text{Brightness on the "White" state}}{\text{Brightness on the "Black" state}}$$

Note 6 : Definition of Cross Talk (CT)

$$CT = |Y_B - Y_A| / Y_A \times 100 (\%)$$

Where

Y_A = Luminance of measured location without gray level 0 pattern (cd/m^2)

Y_B = Luminance of measured location with gray level 0 pattern (cd/m^2)

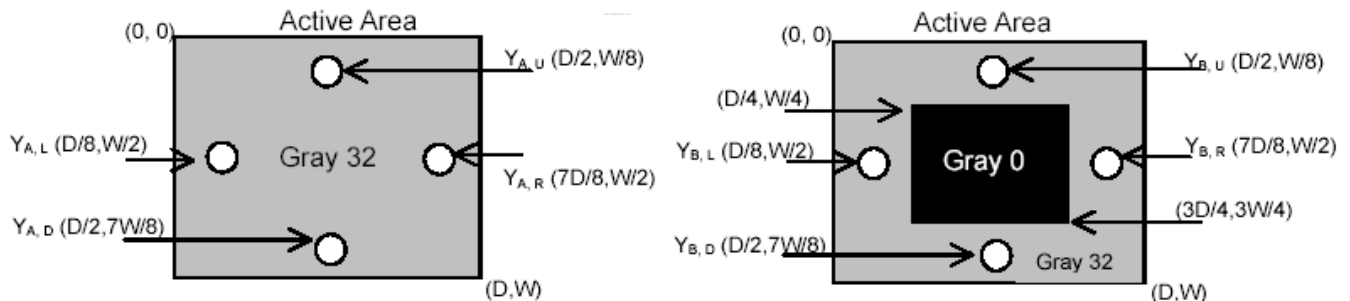

Note 7: Definition of response time:

The output signals of BM-7 or equivalent are measured when the input signals are changed from "Black" to "White" (falling time) and from "White" to "Black" (rising time), respectively. The response time interval between the 10% and 90% of amplitudes. Refer to figure as below.

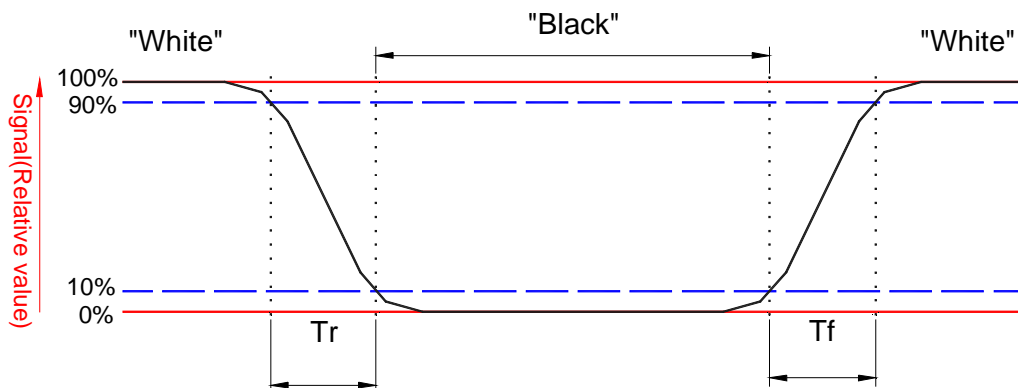

Note 8. Definition of viewing angle

Viewing angle is the measurement of contrast ratio ≥ 10 , at the screen center, over a 180° horizontal and 180° vertical range (off-normal viewing angles). The 180° viewing angle range is broken down as follows; 90° (θ) horizontal left and right and 90° (ϕ) vertical, high (up) and low (down). The measurement direction is typically perpendicular to the display surface with the screen rotated about its center to develop the desired measurement viewing angle.

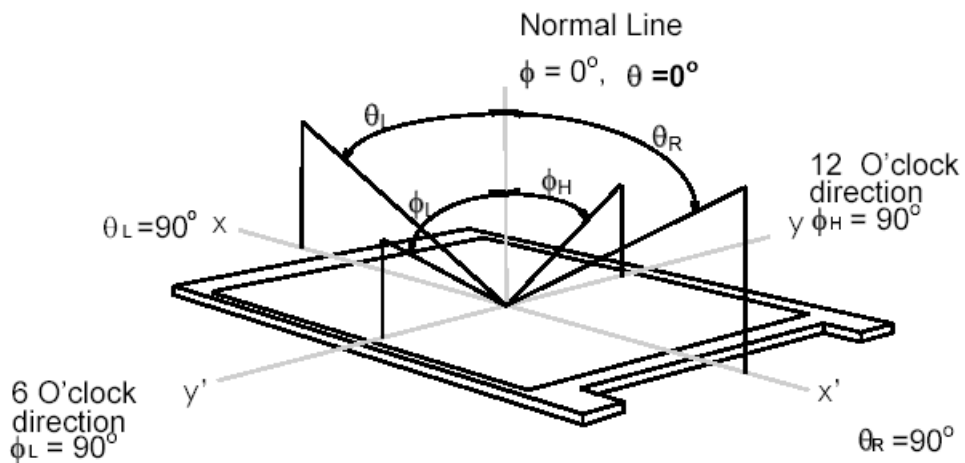

3. Functional Block Diagram

The following diagram shows the functional block of the 17.3 inches wide Color TFT/LCD 40 Pin one channel Module

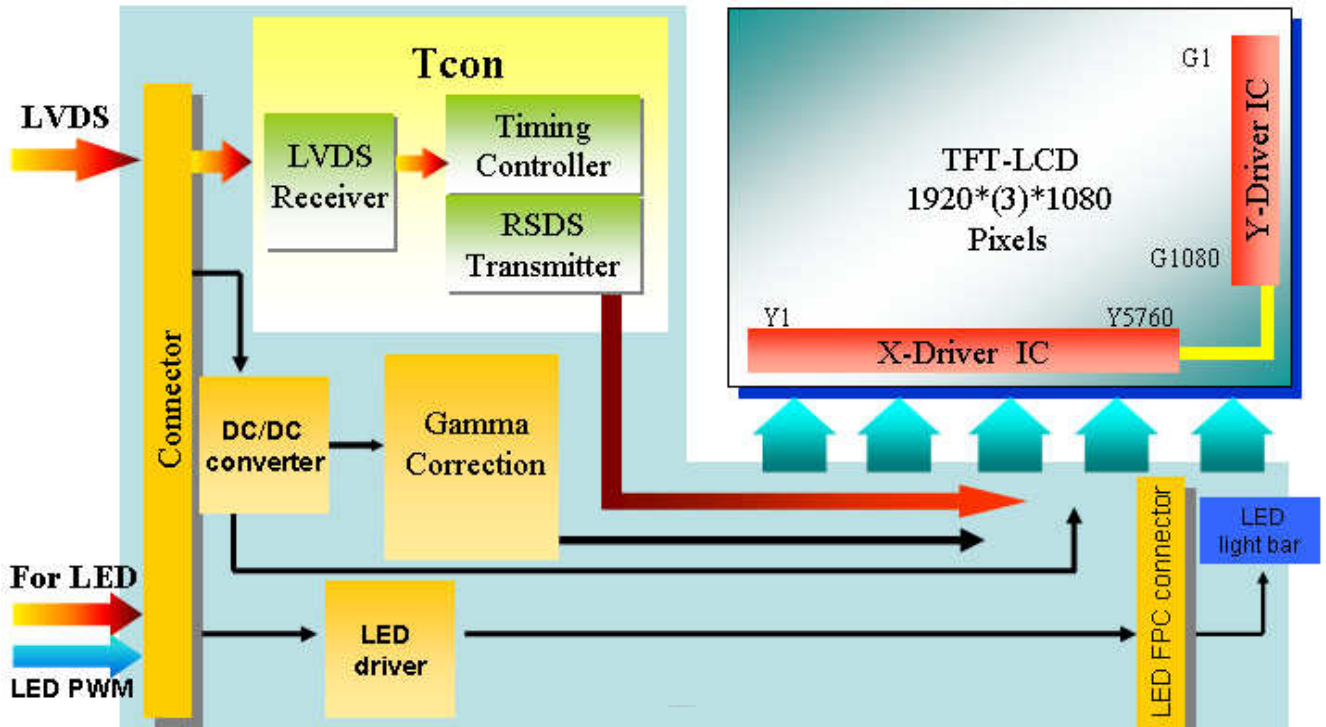

4. Absolute Maximum Ratings

An absolute maximum rating of the module is as following:

4.1 Absolute Ratings of TFT LCD Module

Item	Symbol	Min	Max	Unit	Conditions
Logic/LCD Drive	Vin	-0.3	+4.0	[Volt]	Note 1,2

4.2 Absolute Ratings of Environment

Item	Symbol	Min	Max	Unit	Conditions
Operating Temperature	TOP	0	+50	[°C]	Note 4
Operation Humidity	HOP	5	95	[%RH]	Note 4
Storage Temperature	TST	-20	+60	[°C]	Note 4
Storage Humidity	HST	5	95	[%RH]	Note 4

Note 1: At Ta (25°C)

Note 2: Permanent damage to the device may occur if exceed maximum values

Note 3: LED specification refer to section 5.2

Note 4: For quality performance, please refer to AUO IIS (Incoming Inspection Standard).

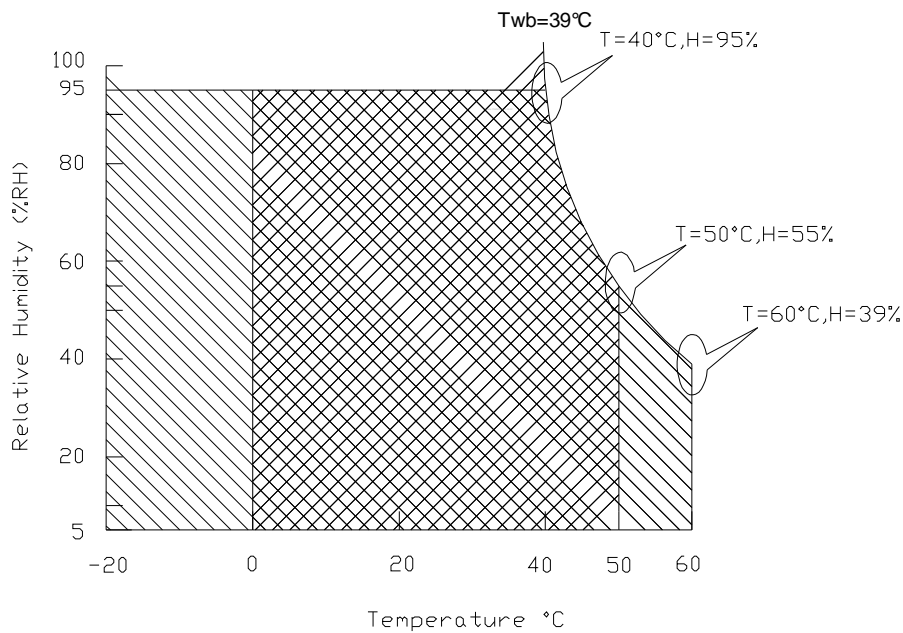

Operating Range

Storage Range

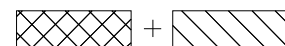

5. Electrical Characteristics

5.1 TFT LCD Module

5.1.1 Power Specification

Input power specifications are as follows;

The power specification are measured under 25°C and frame frequency under 60Hz

Symble	Parameter	Min	Typ	Max	Units	Note
VDD	Logic/LCD Drive Voltage	3.0	3.3	3.6	[Volt]	
PDD	VDD Power	-	-	2	[Watt]	Note 1
IDD	IDD Current	-	350	600	[mA]	Note 1
IRush	Inrush Current	-	-	2000	[mA]	Note 2
VDDrp	Allowable Logic/LCD Drive Ripple Voltage	-	-	100	[mV] p-p	

Note 1 : Maximum Measurement Condition : Black Pattern at 3.3V driving voltage. ($P_{max}=V_{3.3} \times I_{black}$)

Note 2 : Measure Condition

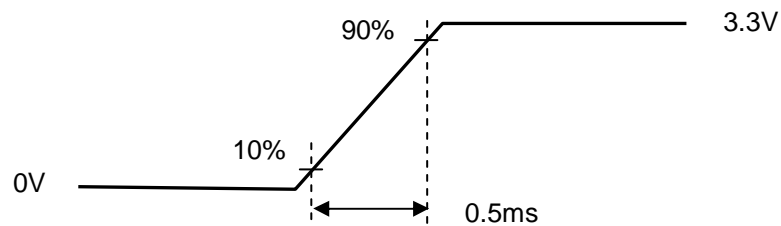
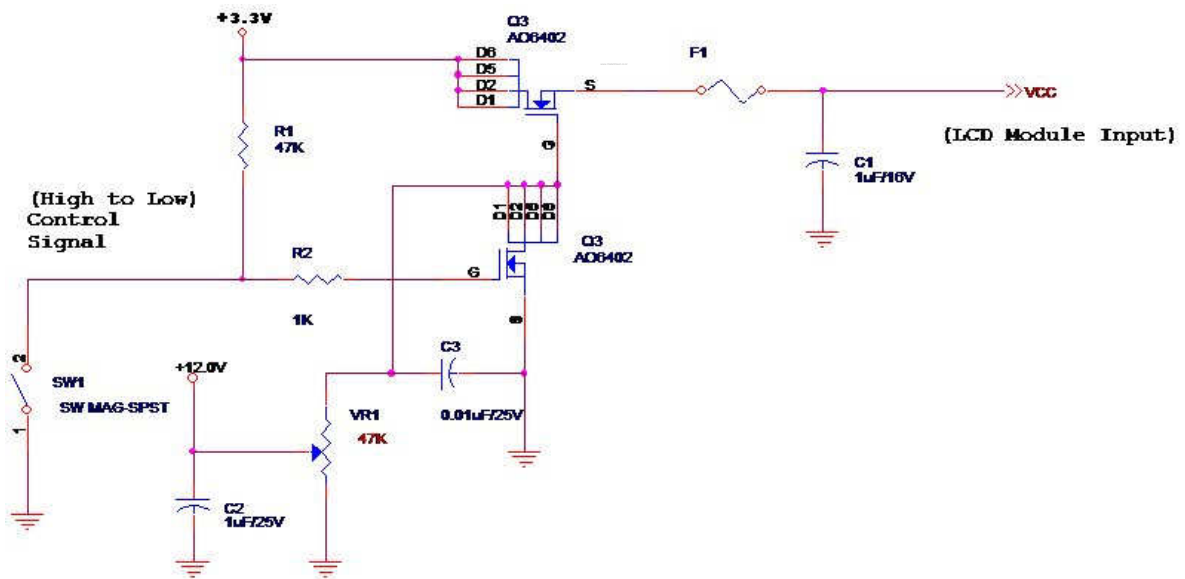

Vin rising time

5.1.2 Signal Electrical Characteristics

Input signals shall be low or High-impedance state when VDD is off.

Signal electrical characteristics are as follows;

Parameter	Condition	Min	Max	Unit
V_{th}	Differential Input High Threshold ($V_{cm}=+1.2V$)	---	100	[mV]
V_{tl}	Differential Input Low Threshold ($V_{cm}=+1.2V$)	-100	---	[mV]
V_{ID}	Differential Input Voltage	100	600	[mV]
V_{cm}	Differential Input Common Mode Voltage	1.125	1.375	[V]

Note: LVDS Signal Waveform

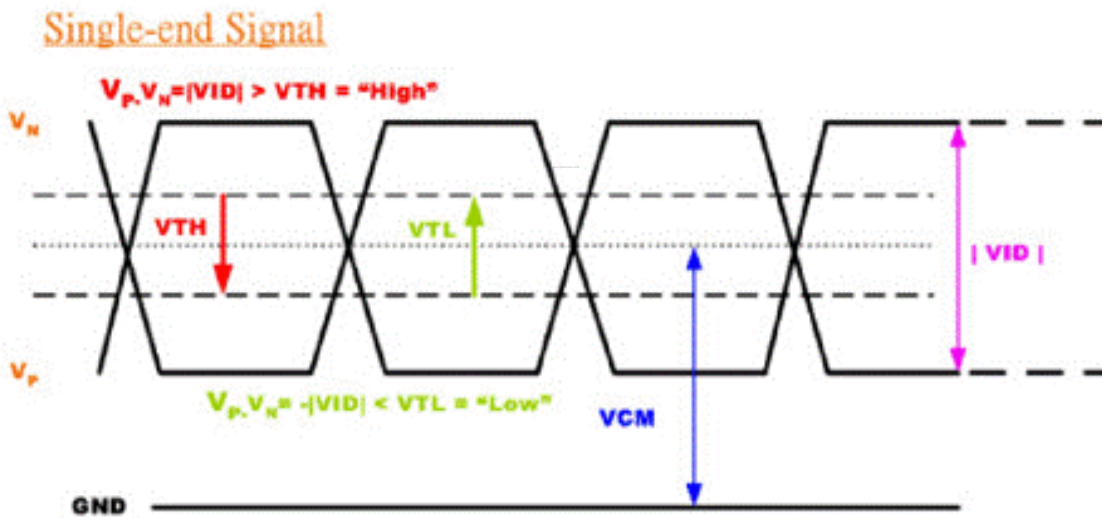



Product Specification

AU OPTRONICS CORPORATION

5.2 Backlight Unit

5.2.1 LED characteristics

Parameter	Symbol	Min	Typ	Max	Units	Condition
Backlight Power Consumption	PLED	-	-	7	[Watt]	(Ta=25°C), Note 1. Vin=12V
LED Life-Time	N/A	10,000	-	-	Hour	(Ta=25°C), Note 2 If=20 mA

Note 1: Calculator value for reference $P_{LED} = V_F$ (Normal Distribution) * I_F (Normal Distribution) / Efficiency

Note 2: The LED life-time define as the estimated time to 50% degradation of initial luminous.

5.2.2 Backlight input signal characteristics

Parameter	Symbol	Min	Typ	Max	Units	Remark
LED Power Supply	VLED	6.0	12.0	21.0	[Volt]	Define as Connector Interface (Ta=25°C)
LED Enable Input High Level	VLED_EN	2.5	-	5.5	[Volt]	
LED Enable Input Low Level		-	-	0.8	[Volt]	
PWM Logic Input High Level	VPWM_EN	2.5	-	5.5	[Volt]	
PWM Logic Input Low Level		-	-	0.8	[Volt]	
PWM Input Frequency	FPWM	100	200	20K	Hz	
PWM Duty Ratio	Duty	5	--	100	%	

6. Signal Interface Characteristic

6.1 Pixel Format Image

Following figure shows the relationship of the input signals and LCD pixel format.

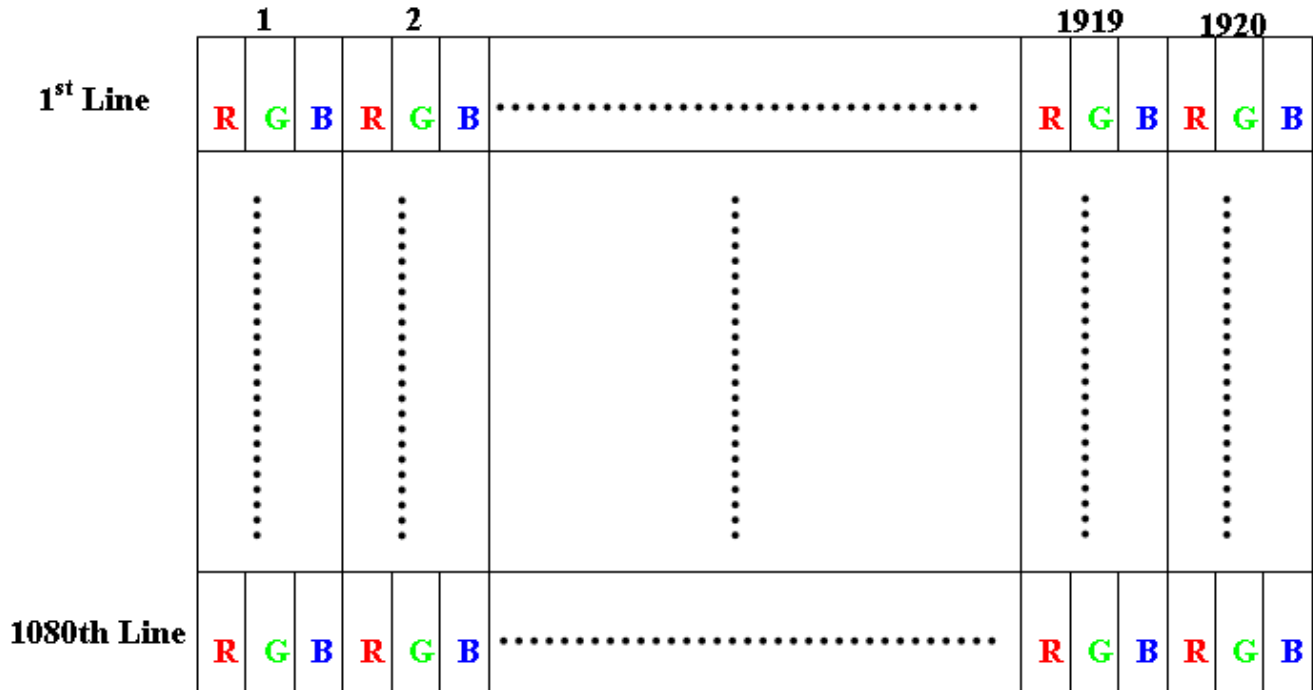

6.2 The Input Data Format

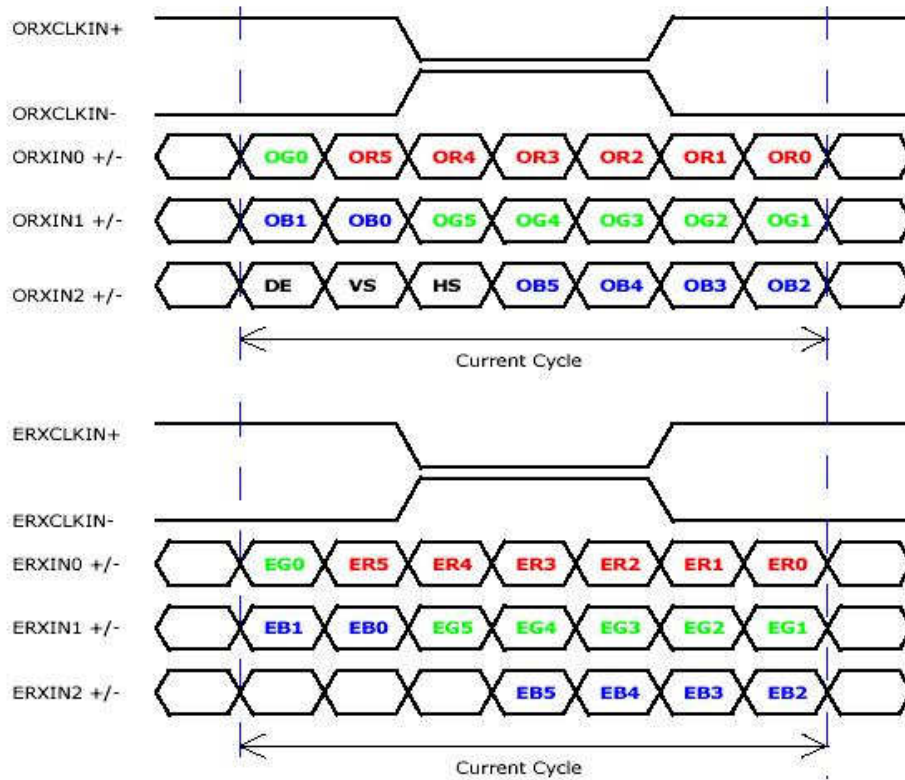

Signal Name	Description	
R5 R4 R3 R2 R1 R0	Red Data 5 (MSB) Red Data 4 Red Data 3 Red Data 2 Red Data 1 Red Data 0 (LSB)	Red-pixel Data Each red pixel's brightness data consists of these 6 bits pixel data.
G5 G4 G3 G2 G1 G0	Green Data 5 (MSB) Green Data 4 Green Data 3 Green Data 2 Green Data 1 Green Data 0 (LSB)	Green-pixel Data Each green pixel's brightness data consists of these 6 bits pixel data.
B5 B4 B3 B2 B1 B0	Blue Data 5 (MSB) Blue Data 4 Blue Data 3 Blue Data 2 Blue Data 1 Blue Data 0 (LSB)	Blue-pixel Data Each blue pixel's brightness data consists of these 6 bits pixel data.
RxCLKIN	Data Clock	The signal is used to strobe the pixel data and



Product Specification

AU OPTRONICS CORPORATION

		DE signals. All pixel data shall be valid at the falling edge when the DE signal is high.
DE	Display Timing	This signal is strobed at the falling edge of RxCLKIN. When the signal is high, the pixel data shall be valid to be displayed.
VS	Vertical Sync	The signal is synchronized to RxCLKIN .
HS	Horizontal Sync	The signal is synchronized to RxCLKIN .

Note: Output signals from any system shall be low or High-impedance state when VDD is off.

6.3 Integration Interface Requirement

6.3.1 Connector Description

Physical interface is described as for the connector on module.

These connectors are capable of accommodating the following signals and will be following components.

Connector Name / Designation	For Signal Connector
Manufacturer	IPEX or Compatible
Type / Part Number	IPEX 20455-040E-12A or Compatible
Mating Housing/Part Number	IPEX 20453-040T-11 or Compatible

6.3.2 Pin Assignment

LVDS is a differential signal technology for LCD interface and high speed data transfer device.

PIN#	Signal Name	Description
1	DIAG_LOOP	NC
2	VDD	Power Supply, 3.3 V (typical)
3	VDD	Power Supply, 3.3 V (typical)
4	V EEDID	DDC 3.3V power
5	TEST	Panel Self Test
6	Clk EEDID	DDC Clock
7	DATA EEDID	DDC Data
8	Odd_Rin0-	- LVDS differential data input (R0-R5, G0) (odd pixels)
9	Odd_Rin0+	+ LVDS differential data input (R0-R5, G0) (odd pixels)
10	VSS	Ground – Shield
11	Odd_Rin1-	- LVDS differential data input (G1-G5, B0-B1) (odd pixels)
12	Odd_Rin1+	+ LVDS differential data input (G1-G5, B0-B1) (odd pixels)
13	VSS	Ground – Shield
14	Odd_Rin2-	- LVDS differential data input (B2-B5, HS, VS, DE) (odd pixels)
15	Odd_Rin2+	+ LVDS differential data input (B2-B5, HS, VS, DE) (odd pixels)
16	VSS	Ground – Shield
17	Odd_ClkIN-	- LVDS differential clock input (odd pixels)
18	Odd_ClkIN+	+ LVDS differential clock input (odd pixels)
19	VSS	Ground – Shield
20	Even_Rin0-	- LVDS differential data input (R0-R5, G0) (even pixels)
21	Even_Rin0+	+ LVDS differential data input (R0-R5, G0) (even pixels)
22	VSS	Ground – Shield

23	Even_Rin1-	- LVDS differential data input (G1-G5, B0-B1) (even pixels)
24	Even_Rin1+	+ LVDS differential data input (G1-G5, B0-B1) (even pixels)
25	VSS	Ground – Shield
26	Even_Rin2-	- LVDS differential data input (B2-B5, HS, VS, DE) (even pixels)
27	Even_Rin2+	+ LVDS differential data input (B2-B5, HS, VS, DE) (even pixels)
28	VSS	Ground – Shield
29	Even_CikIN-	- LVDS differential clock input (even pixels)
30	Even_CikIN+	+ LVDS differential clock input (even pixels)
31	VSSLED	Ground – LED
32	VSSLED	Ground – LED
33	VSSLED	Ground – LED
34	DIAG_LOOP	NC
35	PWM	System PWM Signal Input (+3.3V Swing)
36	LED_EN	LED enable pin (+3.3V Input)
37	NC	NC
38	VDDLED	6V – 21V LED power
39	VDDLED	6V – 21V LED power
40	VDDLED	6V – 21V LED power

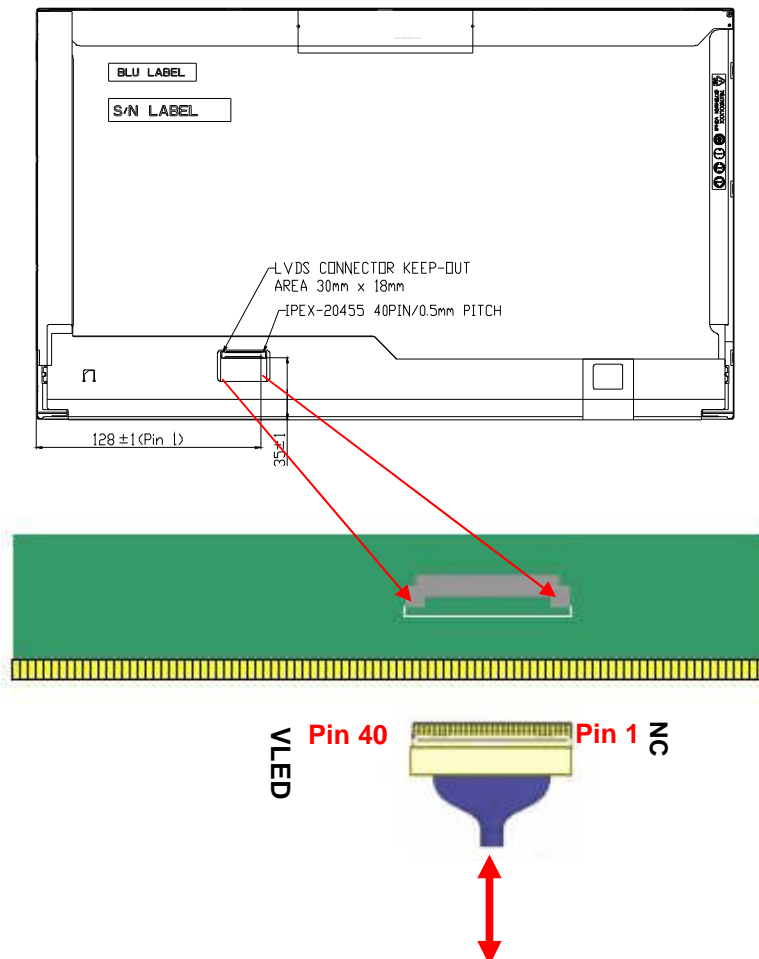

Note1: Input signals shall be low or High-impedance state when VDD is off.

6.4 Interface Timing

6.4.1 Timing Characteristics

Basically, interface timings should match the 1920X1080 / 60Hz manufacturing guide line timing.

Parameter	Symbol	Min.	Typ.	Max.	Unit	
Frame Rate	-	50	60	-	Hz	
Clock frequency	$1/T_{\text{Clock}}$	64.63	71.2	85	MHz	
Vertical Section	Period	T_V	1088	1130	-	T_{Line}
	Active	T_{VD}	1080			
	Blanking	T_{VB}	8	50	-	
Horizontal Section	Period	T_H	990	1050	-	T_{Clock}
	Active	T_{HD}	1920			
	Blanking	T_{HB}	30	90	-	

Note : DE mode only

6.4.2 Timing diagram

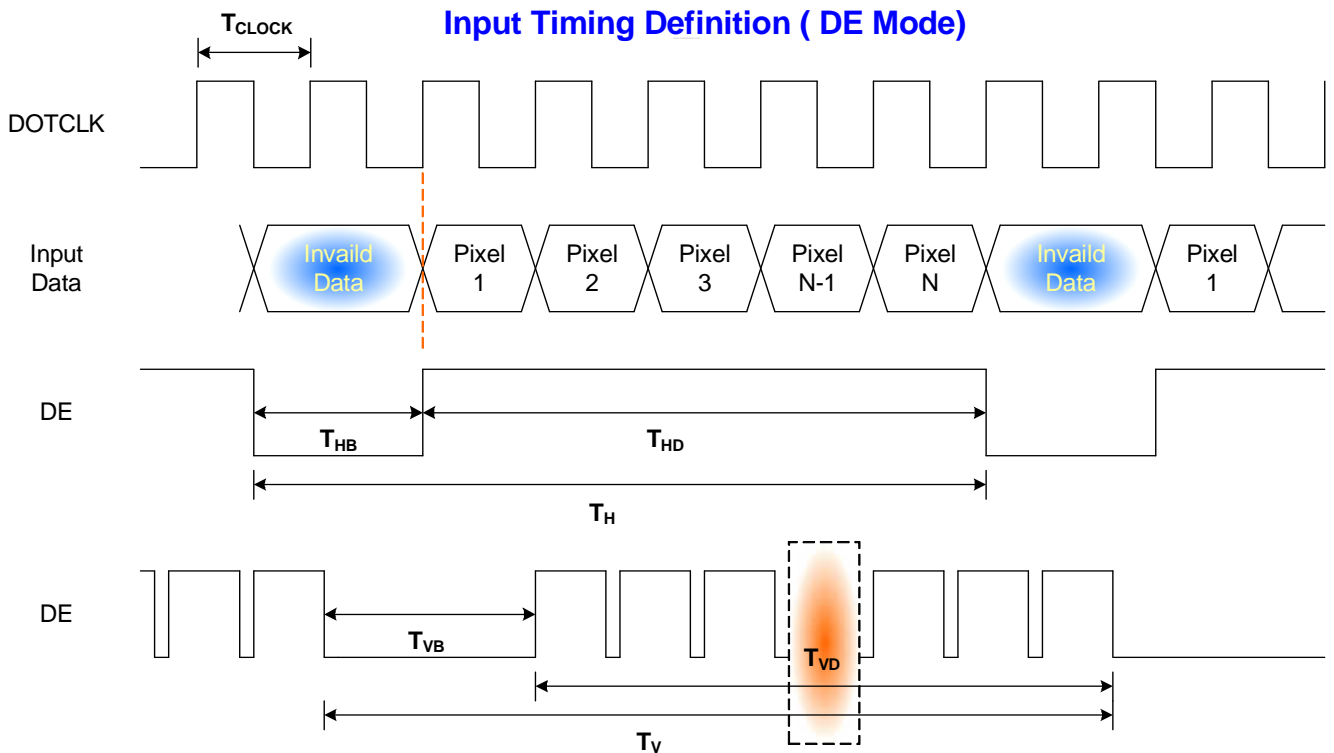

6.5 Power ON/OFF Sequence

Power on/off sequence is as follows. Interface signals and LED on/off sequence are also shown in the chart. Signals from any system shall be Hi-Z state or low level when VDD is off

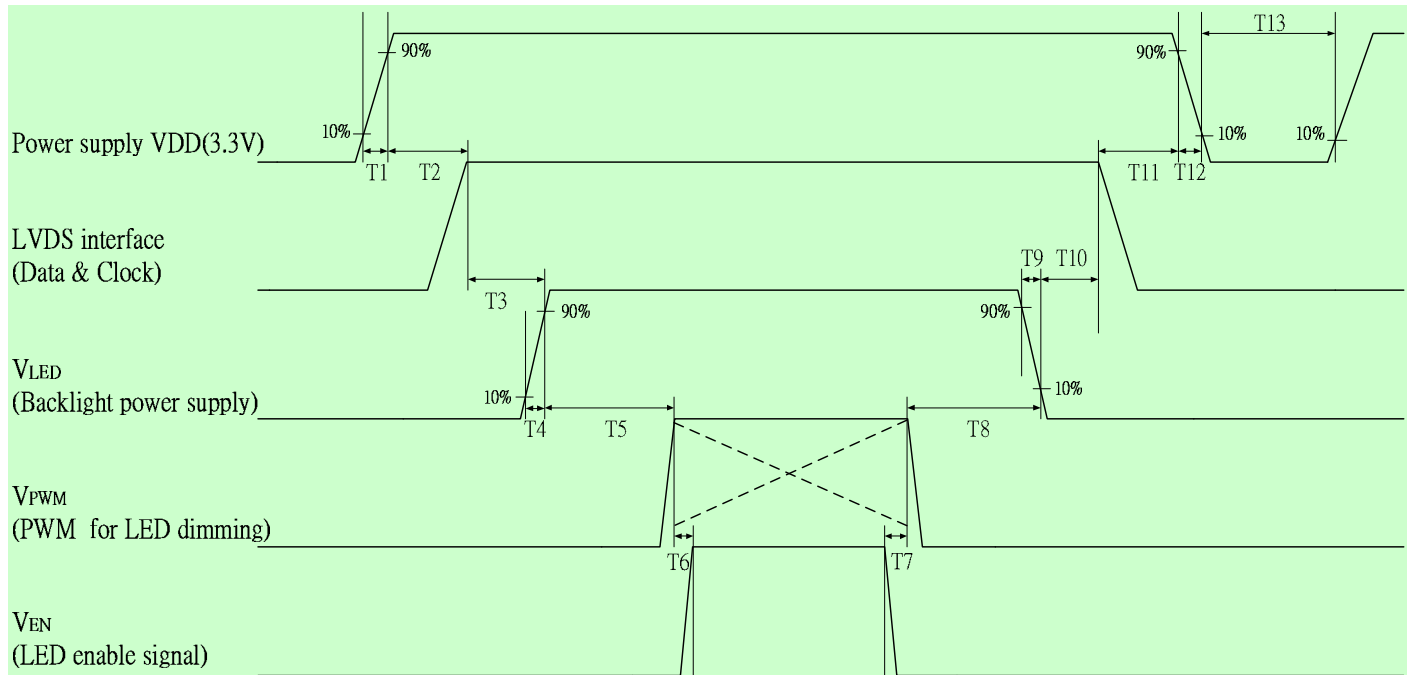

Power Sequence Timing				
Parameter	Value			Units
	Min.	Typ.	Max.	
T1	0.5	-	10	ms
T2	5	-	50	
T3	0.5	-	50	
T4	400	-	-	
T5	200	-	-	
T6	200	-	-	
T7	0.5	-	10	
T8	10	---	---	
T9	10	---	---	
T10	10	---	---	
T11	10	---	---	

Note: If T3, T5, T6 couldn't match above specifications, must request $T3+T5+T6 > 200\text{ms}$ at least

7. Panel Reliability Test

7.1 Vibration Test

Test Spec:

- Test method: Non-Operation
- Acceleration: 1.5 G
- Frequency: 10 - 500Hz Random
- Sweep: 30 Minutes each Axis (X, Y, Z)

7.2 Shock Test

Test Spec:

- Test method: Non-Operation
- Acceleration: 220 G , Half sine wave
- Active time: 2 ms
- Pulse: X,Y,Z .one time for each side

7.3 Reliability Test

Items	Required Condition	Note
Temperature Humidity Bias	Ta= 40°C, 90%RH, 300h	
High Temperature Operation	Ta= 50°C, Dry, 300h	
Low Temperature Operation	Ta= 0°C, 300h	
High Temperature Storage	Ta= 60°C, 35%RH, 300h	
Low Temperature Storage	Ta= -20°C, 50%RH, 250h	
Thermal Shock Test	Ta=-20°C to 60°C, Duration at 30 min, 100 cycles	
ESD	Contact : ±8 KV Air : ±15 KV	Note 1

Note1: According to EN 61000-4-2 , ESD class B: Some performance degradation allowed. No data lost
 . Self-recoverable. No hardware failures.

Remark: MTBF (Excluding the LED): 30,000 hours with a confidence level 90%

8. Mechanical Characteristics

8.1 LCM Outline Dimension

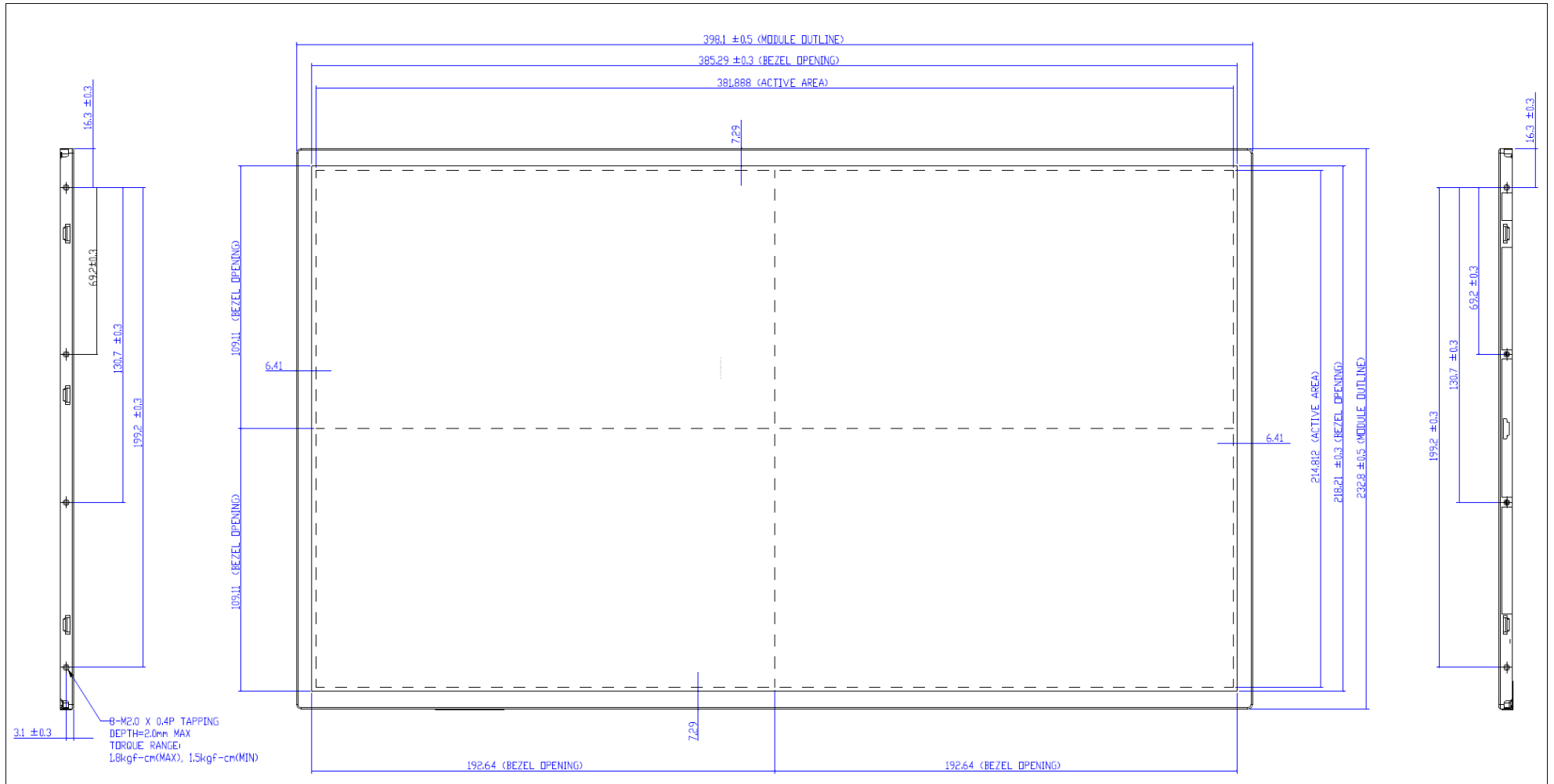

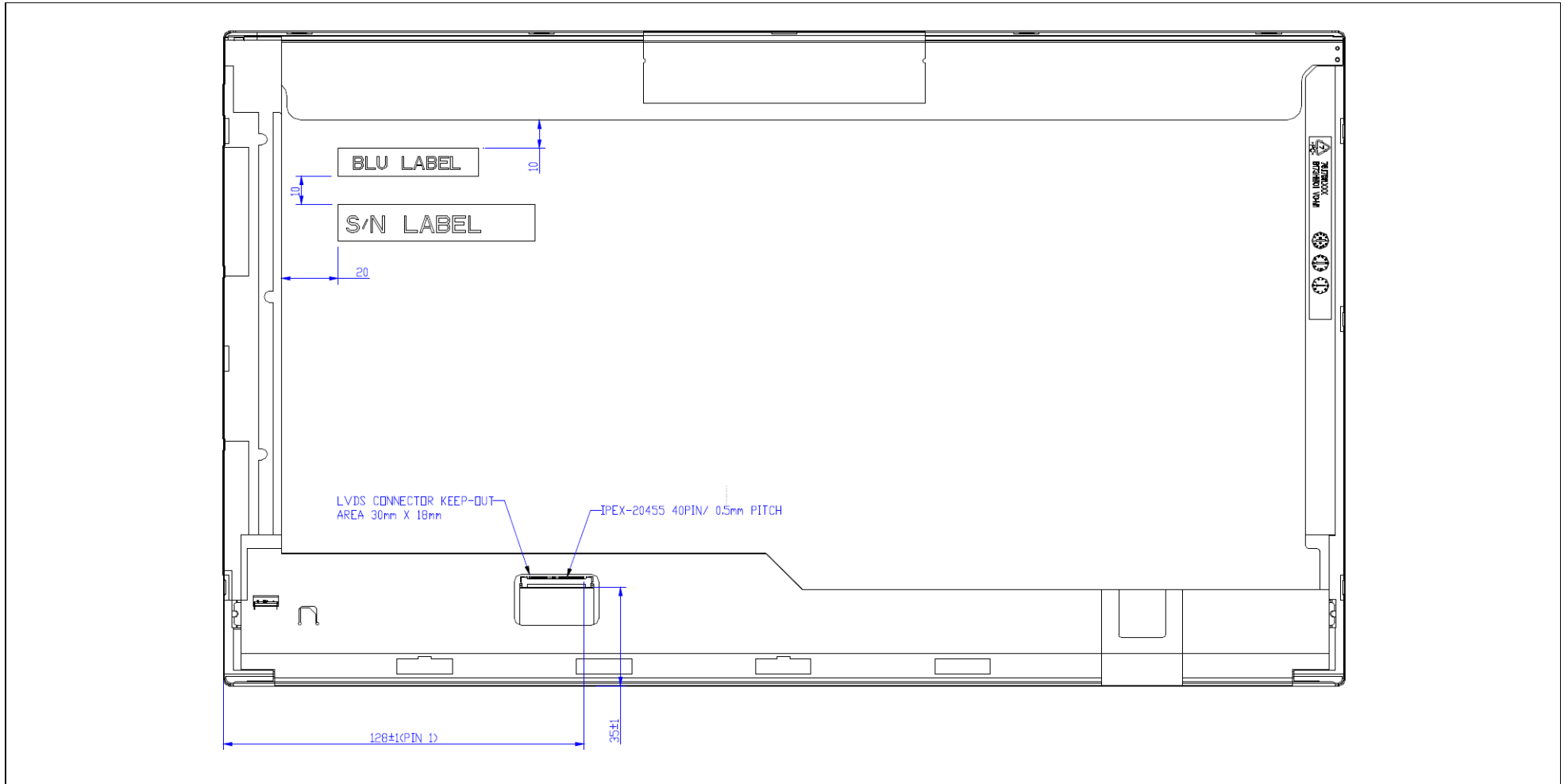

Note: Prevention IC damage, IC positions not allowed any overlap over these areas.

8.2 Screw Hole Depth and Center Position

Maximum Screw penetration from side surface is 2.3 mm

The center of screw hole center location is 3.1 ± 0.2 mm from front surface

Screw Torque: Maximum 2.5 kgf-cm

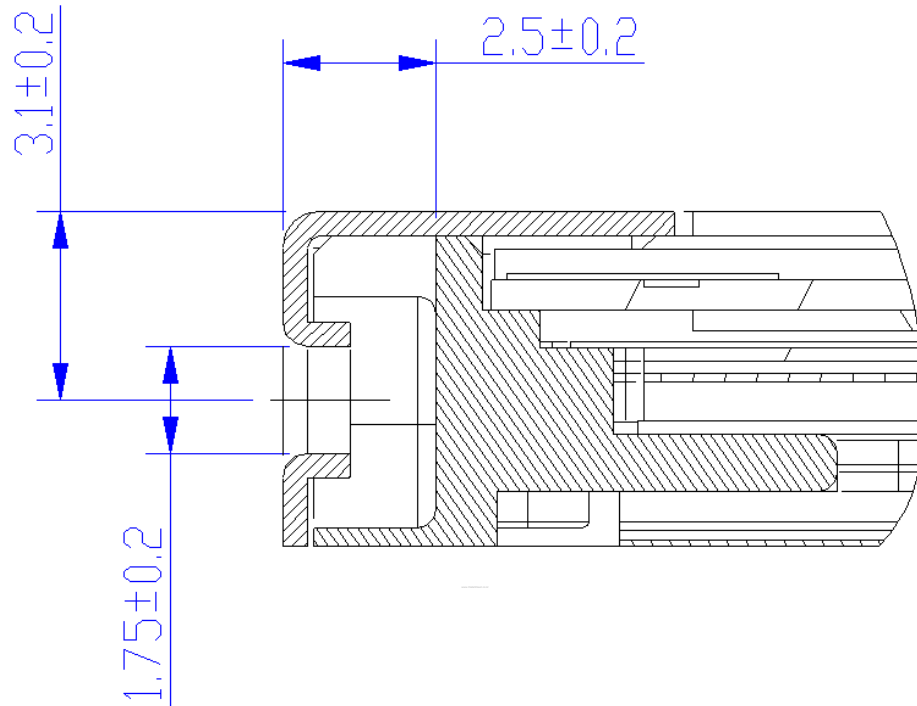



Product Specification

AU OPTRONICS CORPORATION

9. Shipping and Package

9.1 Shipping Label Format

	Manufactured MM/WW Model No: B173HW01 V0 AU Optronics MADE IN CHINA (S3)	
*XXXXXXXXXXXXX.XXXXXX	HW: 1A FW: 1	
		

9.2 Carton Package

The outside dimension of carton is 480 (L)mm x 373 (W)mm x 311 (H)mm

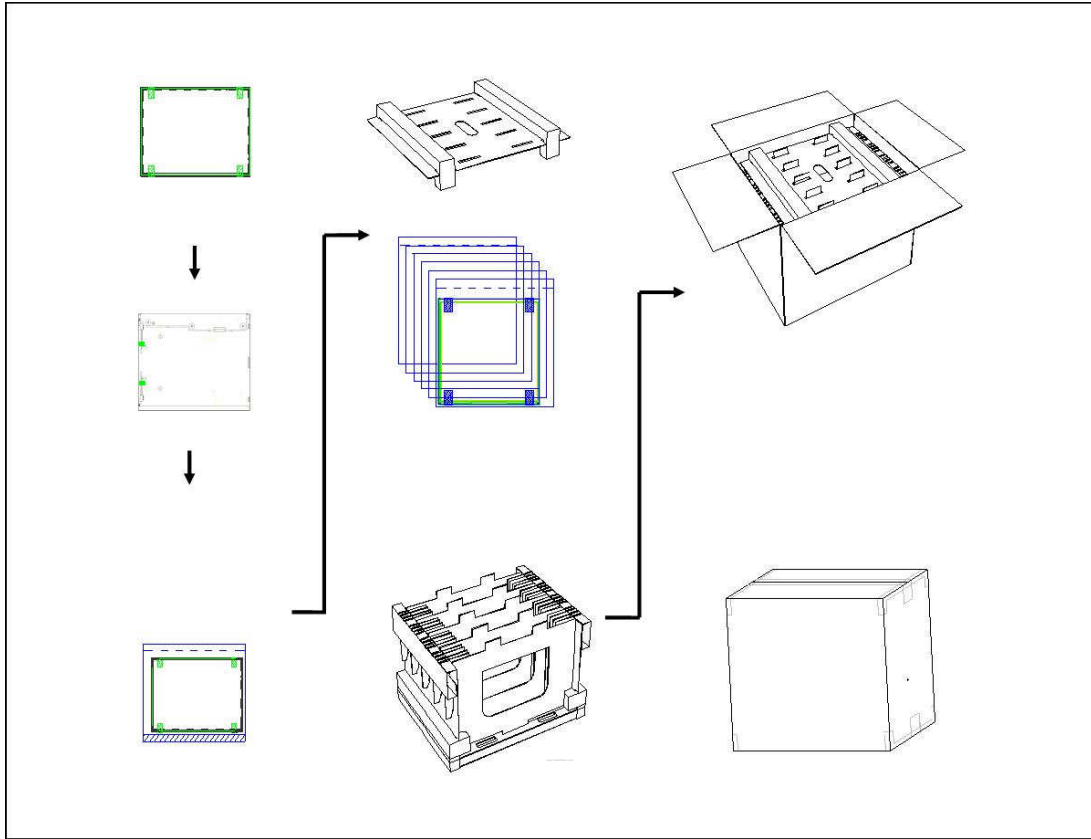

9.3 Shipping Package of Palletizing Sequence

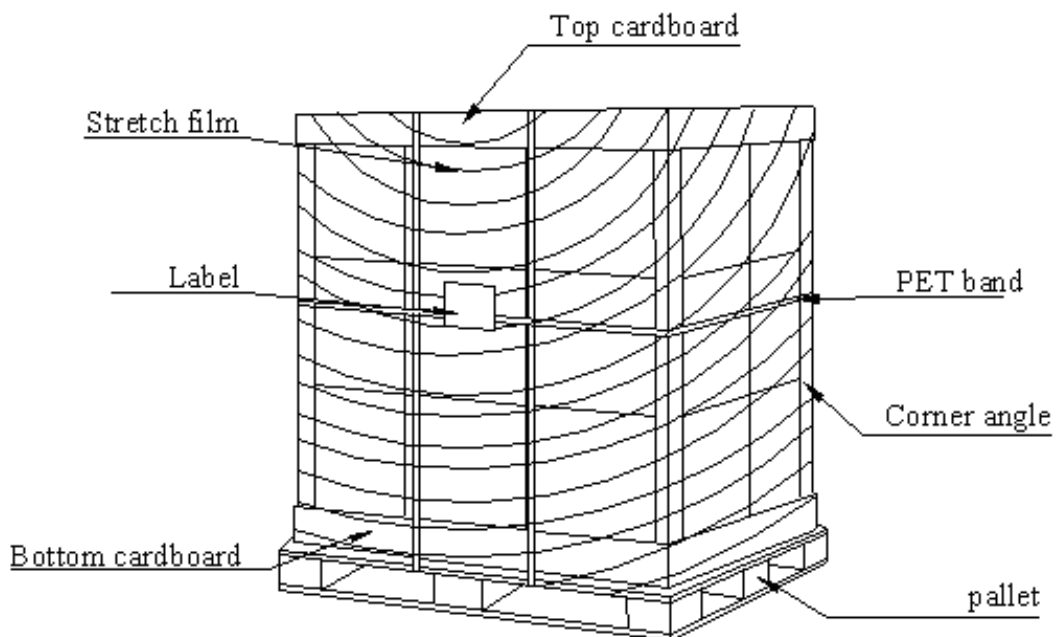



10. Appendix: EDID Description

Address	FUNCTION	Value	Value	Value	Note
HEX		HEX	BIN	DEC	
00	Header	00	00000000	0	
01		FF	11111111	255	
02		FF	11111111	255	
03		FF	11111111	255	
04		FF	11111111	255	
05		FF	11111111	255	
06		FF	11111111	255	
07		00	00000000	0	
08	EISA Manuf. Code LSB	06	00000110	6	
09	Compressed ASCII	AF	10101111	175	
0A	Product Code	9D	10011101	157	
0B	hex, LSB first	10	00010000	16	
0C	32-bit ser #	00	00000000	0	
0D		00	00000000	0	
0E		00	00000000	0	
0F		00	00000000	0	
10	Week of manufacture	01	00000001	1	
11	Year of manufacture	13	00010011	19	
12	EDID Structure Ver.	01	00000001	1	
13	EDID revision #	03	00000011	3	
14	Video input def. (digital I/P, non-TMDS, CRGB)	80	10000000	128	
15	Max H image size (rounded to cm)	26	00100110	38	
16	Max V image size (rounded to cm)	15	00010101	21	
17	Display Gamma (=gamma*100)-100	78	01111000	120	
18	Feature support (no DPMS, Active OFF, RGB, tmg Blk#1)	0A	00001010	10	
19	Red/green low bits (Lower 2:2:2:2 bits)	C8	11001000	200	
1A	Blue/white low bits (Lower 2:2:2:2 bits)	95	10010101	149	
1B	Red x (Upper 8 bits)	9E	10011110	158	
1C	Red y/ highER 8 bits	57	01010111	87	
1D	Green x	54	01010100	84	
1E	Green y	92	10010010	146	
1F	Blue x	26	00100110	38	
20	Blue y	0F	00001111	15	
21	White x	50	01010000	80	



Product Specification

AU OPTRONICS CORPORATION

22	White y	54	01010100	84	
23	Established timing 1	00	00000000	0	
24	Established timing 2	00	00000000	0	
25	Established timing 3	00	00000000	0	
26	Standard timing #1	01	00000001	1	
27		01	00000001	1	
28	Standard timing #2	01	00000001	1	
29		01	00000001	1	
2A	Standard timing #3	01	00000001	1	
2B		01	00000001	1	
2C	Standard timing #4	01	00000001	1	
2D		01	00000001	1	
2E	Standard timing #5	01	00000001	1	
2F		01	00000001	1	
30	Standard timing #6	01	00000001	1	
31		01	00000001	1	
32	Standard timing #7	01	00000001	1	
33		01	00000001	1	
34	Standard timing #8	01	00000001	1	
35		01	00000001	1	
36	Pixel Clock/10000 LSB	A0	10100000	160	
37	Pixel Clock/10000 USB	37	00110111	55	
38	Horz active Lower 8bits	80	10000000	128	
39	Horz blanking Lower 8bits	B4	10110100	180	
3A	HorzAct:HorzBlnk Upper 4:4 bits	70	01110000	112	
3B	Vertical Active Lower 8bits	38	00111000	56	
3C	Vertical Blanking Lower 8bits	32	00110010	50	
3D	Vert Act : Vertical Blanking (upper 4:4 bit)	40	01000000	64	
3E	HorzSync. Offset	6C	01101100	108	
3F	HorzSync.Width	30	00110000	48	
40	VertSync.Offset : VertSync.Width	AA	10101010	170	
41	Horz&Vert Sync Offset/Width Upper 2bits	00	00000000	0	
42	Horizontal Image Size Lower 8bits	7D	01111101	125	
43	Vertical Image Size Lower 8bits	D6	11010110	214	
44	Horizontal & Vertical Image Size (upper 4:4 bits)	10	00010000	16	
45	Horizontal Border (zero for internal LCD)	00	00000000	0	
46	Vertical Border (zero for internal LCD)	00	00000000	0	
47	Signal (non-intr, norm, no stereo, sep sync, neg pol)	18	00011000	24	



Product Specification

AU OPTRONICS CORPORATION

48	Detailed timing/monitor	00	00000000	0	
49	descriptor #2	00	00000000	0	
4A		00	00000000	0	
4B		0F	00001111	15	
4C		00	00000000	0	
4D		00	00000000	0	
4E		00	00000000	0	
4F		00	00000000	0	
50		00	00000000	0	
51		00	00000000	0	
52		00	00000000	0	
53		00	00000000	0	
54		00	00000000	0	
55		00	00000000	0	
56		00	00000000	0	
57		00	00000000	0	
58		00	00000000	0	
59		20	00100000	32	
5A	Detailed timing/monitor	00	00000000	0	
5B	descriptor #3	00	00000000	0	
5C		00	00000000	0	
5D		FE	11111110	254	
5E		00	00000000	0	
5F	Manufacture	41	01000001	65	A
60	Manufacture	55	01010101	85	U
61	Manufacture	4F	01001111	79	O
62		0A	00001010	10	
63		20	00100000	32	
64		20	00100000	32	
65		20	00100000	32	
66		20	00100000	32	
67		20	00100000	32	
68		20	00100000	32	
69		20	00100000	32	
6A		20	00100000	32	
6B		20	00100000	32	
6C	Detailed timing/monitor	00	00000000	0	
6D	descriptor #4	00	00000000	0	
6E		00	00000000	0	



Product Specification

AU OPTRONICS CORPORATION

6F		FE	11111110	254	
70		00	00000000	0	
71	Manufacture P/N	42	01000010	66	B
72	Manufacture P/N	31	00110001	49	1
73	Manufacture P/N	37	00110111	55	7
74	Manufacture P/N	33	00110011	51	3
75	Manufacture P/N	48	01001000	72	H
76	Manufacture P/N	57	01010111	87	W
77	Manufacture P/N	30	00110000	48	0
78	Manufacture P/N	31	00110001	49	1
79	Manufacture P/N	20	00100000	32	
7A	Manufacture P/N	56	01010110	86	V
7B	Manufacture P/N	30	00110000	48	0
7C		20	00100000	32	
7D		0A	00001010	10	
7E	Extension Flag	00	00000000	0	
7F	Checksum	61	01100001	97	