

1300 nm E-LED Transmitter and PIN/Preamp Receiver for Single-Mode Fiber

Technical Data

HFBR-0305 Series

Features

- Distances up to 14 km at Signal Rates of 20 MBd
- Performance Specified with Single-Mode Fiber Cables
- Wave Solder and Aqueous Wash Process Compatible
- Panel Mount ST Connectors
- Pinout Compatible with HFBR-0400 Series Parts

Applications

- Single-Mode Extensions to Ethernet (10Base-F) Links
- Proprietary Links Using Single-Mode Fiber

Description

The HFBR-0305 Series is designed to provide the most cost-effective single-mode solution, and is pin-compatible with HFBR-0400 and HFBR-0300 families of 820 and 1300 nm fiber optic links for multi-mode fiber. This allows designers to use a single circuit and board layout for 820 nm multimode fiber links, 1300 nm multimode fiber links, and 1300 nm single-mode fiber links. Upgrading a multimode solution to single-mode fiber is as simple as switching components on a board.

Transmitter

The HFBR-1315TM/1315M single-mode fiber-optic transmitter contains a 1300 nm edge-emitting LED (E-LED) capable of efficiently launching optical power into single-mode fiber. Because it is an LED, and not a laser, the drive circuit is simple and compatible with drive circuits for multimode LED transmitters.

Receiver

The HFBR-2315T/2315M receiver contains an InGaAs PIN photodiode and a low-noise transimpedance preamplifier operating in the 1300 nm wavelength region. The HFBR-2315T/2315M receives an optical signal and converts it to an analog voltage. The buffered output is an emitter-follower, with a frequency response from dc to typically 125 MHz.



Package

HFBR-0305 Series transmitters and receivers are housed in a dual-in-line package made of high strength, heat resistant, chemical resistant, and UL V-0 flame retardant plastic. The HFBR-1315TM/1315M is a stainless steel, threaded ST port (panel mountable); the HFBR-1315M is a stainless steel, unthreaded ST port. The HFBR-2315T is a black, non-conductive plastic threaded ST port (panel mountable); the HFBR-2315M is a stainless steel, unthreaded ST port.

Package Options

	Metal Port	Plastic Port
Transmitter:		
Threaded	HFBR-1315TM	N/A
Unthreaded	HFBR-1315M	N/A
Receiver:		
Threaded	N/A	HFBR-2315T
Unthreaded	HFBR-2315M	N/A

ESD Handling Precautions

The HFBR-0305 Series products are MIL-STD 883C Method 3015.4 Class 1 devices. Normal static precautions should be taken in handling and assembly of this component to prevent damage and/or degradation which may be induced by electrostatic discharge (ESD)

Solder Processing

The HFBR-0305 Series products are compatible with either hand or wave solder processes. When soldering, it is advisable to leave the protective cap on the port to keep the optics clean. Good system performance requires clean port optics and cable ferrules to avoid obstructing the optical path. Clean compressed air is often sufficient to remove particles of dirt; methanol on a cotton swab also works well.

Wash Processing - Chemical Resistance

The HFBR-0305 Series package is compatible with the following chemicals for cleaning and degreasing:

- Aqueous Wash
- Naptha
- Alcohol (methyl, isopropyl, isobutyl)
- Aliphatics (hexane, heptane)

The following chemicals are not recommended as they will damage the package: Partially halogenated hydrocarbons such as 1,1,1 Trichloroethane, Ketones such as MEK, Acetone, Chloroform, Ethyl Acetate, Methylene Dichloride and N-methylpyrrolidone.

Panel Mounting of Threaded ST Package Style

Any standard 3/8 - 32 UNEF-2B threaded nut and washer can be used to secure the threaded ST receptacle to the chassis wall, provided the overall thickness of the chassis wall, washer and nut are less than 5.1 mm (0.2 inch). Agilent supplies the HFBR-4411 kit which consists of 100 each, nuts and washers per the figure below.

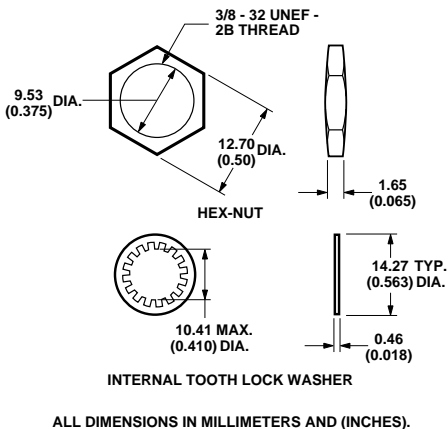

When preparing the chassis wall for panel mounting, use the mounting template in the figure below. When tightening the nut, torque should not exceed 0.8 N-m (8.0 in-lb). Note that the maximum nut dimension exceeds the width of the port package, so approximately 2 mm of space between device packages is required to allow nuts to be mounted on adjacent ports.

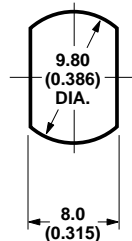

Flame Resistance

The HFBR-0305 Series package is made with UL V-0 flame retardant plastic material.

Electrostatic Discharge (ESD)

Static discharges can occur to the exterior of the equipment chassis containing the HFBR-0305 Series parts. To the extent that their connector receptacles are exposed to the outside of the equipment chassis, they may be subject to whatever ESD system level test criteria that the equipment is intended to meet.

Radiated Susceptibility

Equipment utilizing these products will be subject to EMI fields in some environments. These HFBR-0305 Series products are expected to withstand fields of up to 10 volts per meter, when tested on a circuit card in free space without an equipment chassis, with no measurable effect on their performance. A suggested test method is based on the equipment procedure specified in IEC 801-3.

Pinout Description HFBR-1315TM/1315M Transmitters

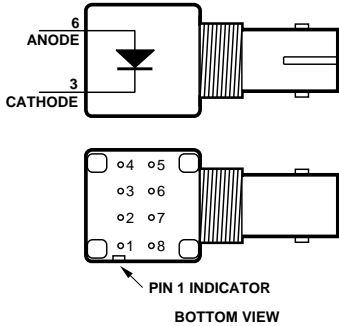

PIN	FUNCTION
1†	N.C.
2*	N.C.
3	CATHODE
4†	N.C.
5†	N.C.
6	ANODE
7	N.C.
8†	N.C.

* THERE IS NO PIN 2. I.E., IN THE NUMBER 2 PIN POSITION, THERE IS NO PHYSICAL PIN.

† PINS 1, 4, 5, AND 8 ARE ISOLATED FROM THE INTERNAL CIRCUITRY, BUT ARE ELECTRICALLY CONNECTED TO EACH OTHER AND TO THE METAL PORT.

HFBR-2315T/2315M Receivers

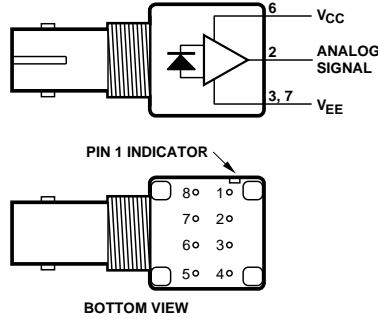

PIN	FUNCTION
1†	N.C.
2	SIGNAL
3*	VEE
4†	N.C.
5†	N.C.
6	VCC
7*	VEE
8†	N.C.

* PINS 3 AND 7 ARE ELECTRICALLY CONNECTED TO THE HEADER.

† PINS 1, 4, 5, AND 8 ARE ISOLATED FROM THE INTERNAL CIRCUITRY, BUT ARE ELECTRICALLY CONNECTED TO EACH OTHER (AND TO THE PORT IF METAL).

Mechanical Dimensions

All dimensions are in millimeters and (inches)

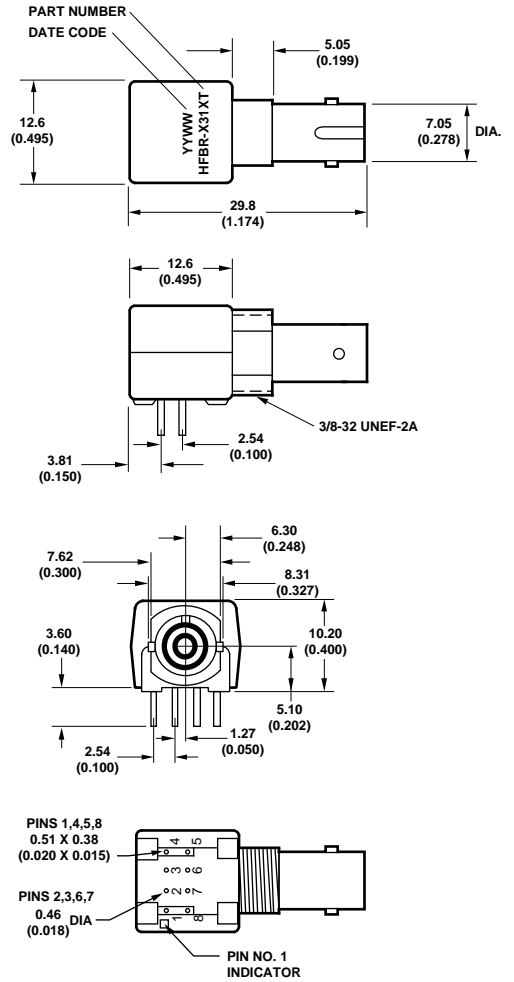

Recommended Operating Conditions for HFBR-0305 Series Products

Parameter	Symbol	Min.	Typ.	Max.	Unit	Reference
Operating Temperature - Ambient	T_A	0		70	°C	
Supply Voltage	V_{CC}	4.75		5.25	V	Note 1

Note:

- The HFBR-2315T/2315M signal output is referenced to V_{CC} , and does not reject noise from the V_{CC} power supply. Consequently, the V_{CC} power supply must be filtered.

Link Performance: At Data Rates 1-20 MBd

Parameter	Symbol	Min.	Typ.	Max.	Unit	Conditions	Reference
Optical Power Budget with Single-Mode Fiber Cables	OPB	9	18		dB	0 to 70°C	Note 1
Link Distance with Single-Mode Fiber Cables	ℓ	14			km	0 to 70°C	Note 2

Notes:

- Optical Power Budget applies to HFBR-1315TM/1315M and HFBR-2315T/2315M in the recommended application circuit (Figures 1 and 2). Worst case transmitter coupled power (P_T) is -27 dBm peak, -30 dBm average. Worst case receiver sensitivity is -36 dBm peak, -39 dBm average. Refer to Application Note 1082 for details.
- Link distance is based on fiber with 0.5 dB/km attenuation, and assumes 1 dB for loss of in-line splices or connectors, and 1 dB margin for LED aging: $(9 \text{ dB OPB} - 1 \text{ dB in-line splice loss} - 1 \text{ dB aging margin}) / (0.5 \text{ dB/km}) = 14 \text{ km}$.

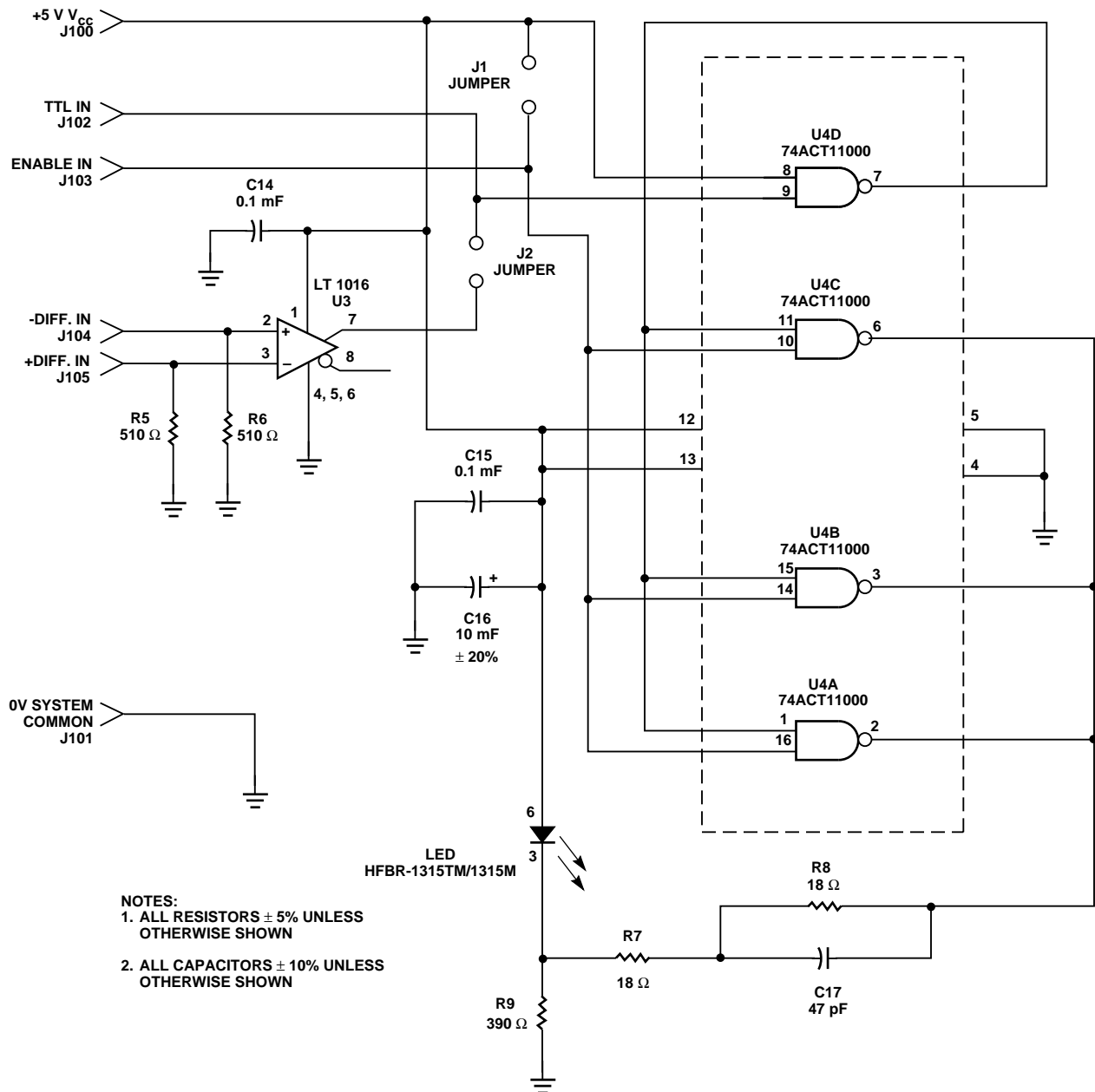

Figure 1. Recommended Transmitter Circuit.

HFBR-1315TM/1315M - Transmitter Absolute Maximum Ratings

Parameter	Symbol	Min.	Max.	Unit	Condition
Storage Temperature	T_S	-40	85	°C	
Operating Temperature	T_A	-40	85	°C	
Lead Soldering Cycle Temperature			260	°C	Note 1
Lead Soldering Cycle Time			10	sec	
Forward Input Current dc	I_{FDC}		100	mA	
Forward Input Current, Peak	I_{FPK}		175	mA	1 sec pulse
Reverse Input Voltage	V_R		2	V	

Notes:

- 2.0 mm from where leads enter case.

CAUTION: It is advised that normal static precautions be taken in handling or assembly of these components to prevent damage and/or degradation which may be induced by ESD.

HFBR-1315TM/1315M - Transmitter Electrical/Optical Characteristics

($T_A = 0^\circ\text{C}$ to 70°C , $I_F = 100$ mA unless otherwise specified)

Parameter	Symbol	Min.	Typ. ^[1]	Max.	Unit	Condition	Reference
Forward Voltage	V_F	1.1	1.5	1.9	V	$T_A = 25^\circ\text{C}$	Figure 3
		1.0		2.0			
Forward Voltage Temperature Coefficient	$\Delta V_F/\Delta T$		-3.4		mV/°C		
Center Emission Wavelength	λ_C	1265	1310	1380	nm		
Spectral Width - FWHM	$\Delta\lambda$		95	125	nm	$T_A = 25^\circ\text{C}$	
				140			
Optical Power Temperature Coefficient	$\Delta P_T/\Delta T$		-0.07		dB/°C		
Reverse Leakage Current	I_R			200	μA	$T_A = 25^\circ\text{C}$, $V_R = -2$ V	
Thermal Resistance	θ_{JA}		105		°C/W		Note 2

Notes:

- Typical data are at $T_A = 25^\circ\text{C}$.
- Thermal resistance is measured with the transmitter coupled to a connector assembly and mounted on a printed circuit board; $\theta_{JC} < \theta_{JA}$.

HFBR-1315TM/1315M - Transmitter Optical Output Power and Dynamic Characteristics

Parameter	Symbol	Min.	Typ. ^[1]	Max.	Unit	Conditions		Reference
						T _A	I _{F,peak}	
Peak Power Single-mode	P _T	-23	-21	-17	dBm	25°C	100 mA	Note 2 Figure 4
		-27		-15		0-70°C	100 mA	
Rise, Fall Time (10% to 90%)	t _r , t _f			4.5	ns	0-70°C	100 mA, No Pre-bias	Note 4 Figure 5
Rise, Fall Time (10% to 90%)	t _r , t _f		2.6 1.6		ns	0-70°C	100 mA, With Pre-bias	Note 4 Figure 1

Notes:

1. Typical data are at T_A = 25°C.
2. Optical power is measured with a large area detector at the end of 1 meter of single-mode cable, with an ST* precision ceramic ferrule (MIL-STD-83522/13), which approximates a standard test connector.
3. When changing from μW to dBm, the optical power is referenced to 1 mW (1000 μW). Optical power
P(dBm) = 10*log[P(μW)/1000μW].
4. Optical rise and fall times are measured from 10% to 90% with single-mode fiber. The “No Pre-bias” response time is measured in the recommended test circuit (50 ohm load, Figure 5) at 25 MHz, 50% duty cycle. The response time “With Pre-bias” is measured in the recommended application circuit (Figure 1).

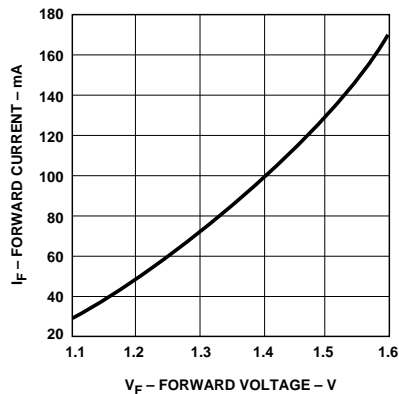

Figure 3. Typical Forward Voltage and Current Characteristics, 25°C.

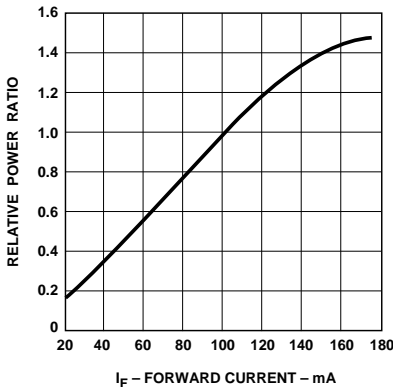

Figure 4. Normalized Transmitter Output Power vs. Forward Current, 25°C.

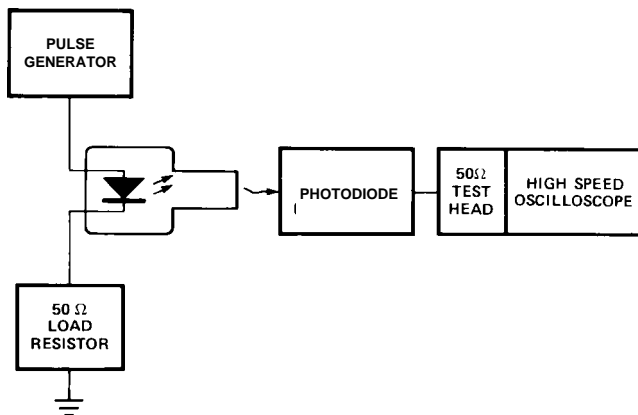

Figure 5. Test Circuit for Measuring t_r, t_f Without Pre-Bias.

HFBR-2315TM/2315M - Receiver Absolute Maximum Ratings

Parameter	Symbol	Min.	Max.	Unit	Condition
Storage Temperature	T_S	-55	85	°C	
Operating Temperature	T_A	-40	+85	°C	
Lead Soldering Cycle Temperature			260	°C	Note 1
Lead Soldering Cycle Time			10	sec	
Signal Pin Voltage	V_O	-0.5	V_{CC}	V	
Supply Voltage	$(V_{CC} - V_{EE})$	-0.5	6.0	V	Note 2
Output Current	I_O		25	mA	

CAUTION: It is advised that normal static precautions be taken in handling or assembly of these components to prevent damage and/or degradation which may be induced by ESD.

HFBR-2315T/2315M - Electrical/Optical and Dynamic Characteristics

($T_A = 0^\circ\text{C}$ to 70°C ; $4.75\text{ V} < (V_{CC} - V_{EE}) < 5.25\text{ V}$; power supply must be filtered per note 2)

Parameter	Symbol	Min.	Typ. ^[3]	Max.	Unit	Condition	Reference
Responsivity, Single-Mode Fiber	R_P	8.5	17	24	mV/ μW	$\lambda_p = 1300\text{ nm}$, 50 MHz	Note 4, Figures 6, 10
RMS Output Noise Voltage	V_{NO}		0.4	0.59	mV _{RMS}	@100 MHz, $P_R = 0\text{ mW}$	Note 5 Figure 7
				1.0	mV _{RMS}	Unfiltered Bandwidth $P_R = 0\text{ mW}$	
Equivalent Optical Noise Input Power (RMS)	$P_{N,RMS}$		-45	-41.5	dBm	@100 MHz, $P_R = 0\text{ mW}$	Note 5
			0.032	0.071	μW		
Peak Input Optical Power, Single-Mode	P_R			-14	dBm	50 MHz, 1 ns PWD	Note 6 Figure 8
				40	μW		
Output Impedance	Z_O		30		Ω	$f = 50\text{ MHz}$	
DC Output Voltage	$V_{O,DC}$	0.8	1.8	2.6	V	$V_{CC} = 5\text{ V}$, $V_{EE} = 0\text{ V}$ $P_R = 0\text{ mW}$	
Supply Current	I_{CC}		9	15	mA	$R_{LOAD} = \infty$	
Electrical Bandwidth	BW_E	75	125		MHz	-3 dB electrical	Note 7
Bandwidth * Rise Time			0.41		Hz * s		Note 8
Electrical Rise, Fall Times, 10-90%	$t_{r,f}$		3.3	5.3	ns	$P_R = -21\text{ dBm Peak}$, @ 50 MHz	Note 9 Figure 9
Pulse-Width Distortion	PWD		0.4	1.0	ns	$P_R = -14\text{ dBm, Peak}$, Single-Mode Fiber	Note 10 Figure 8
Overshoot			2		%	$P_R = -21\text{ dBm, Peak}$	Note 11

Notes:

- 2.0 mm from where leads enter case.
- The signal output is an emitter follower, which does not reject noise from V_{CC} . Consequently, the power supply must be filtered. The recommended supply is +5 V on V_{CC} for typical usage with +5 V ECL logic. A -5 V supply on V_{EE} is used for test purposes to minimize supply noise.
- Typical specifications are for operation at $T_A = 25^\circ\text{C}$, $V_{CC} = +5$ V, $V_{DC} = 0$ V, $V_{EE} = 0$ V.
- The test circuit layout should be in accordance with good high frequency circuit design techniques.
- Measured with a Mini-Circuits 9-pole "brick wall" low-pass filter, BLP-100, with -3 dB bandwidth of 100 MHz.
- 14 dBm is the maximum peak input optical power for which pulse-width distortion is less than 1 ns.
- Electrical bandwidth is the frequency where the responsivity is -3 dB (electrical) below the responsivity measured at 50 MHz.
- The bandwidth * risetime product is typically 0.41 because the HFBR-2315T/2315M has a second-order bandwidth limiting characteristic.
- The specified rise and fall times are referenced to a fast square wave

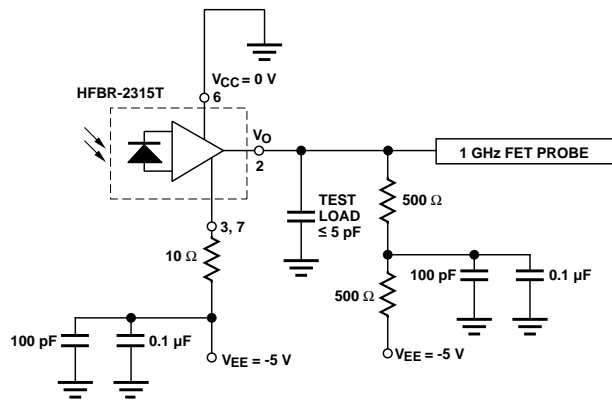

Figure 6. HFBR-2315T/2315M Receiver Test Circuit.

- optical source. Rise and fall times measured using an LED optical source with a 2.0 ns rise and fall time (such as the HFBR-1315TM/1315M) will be approximately 0.6 ns longer than the specified rise and fall times. E.g.: measured $t_{r,f} \cong [(\text{specified } t_{r,f})^2 + (\text{test source optical } t_{r,f})^2]^{1/2}$
- 10 ns pulse width, 50% duty cycle, at the 50% amplitude point of the waveform.
 - Percent overshoot is defined as: $((V_{PK} - V_{100\%})/V_{100\%}) \times 100\%$. The overshoot is typically 2% with an input optical rise time < 1.5 ns.

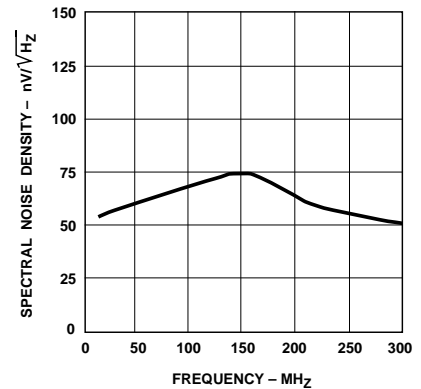

Figure 7. Typical Output Spectral Noise Density vs. Frequency.

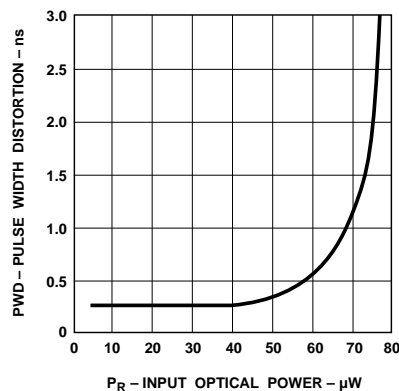

Figure 8. Typical Pulse Width Distortion vs. Peak Input Power.

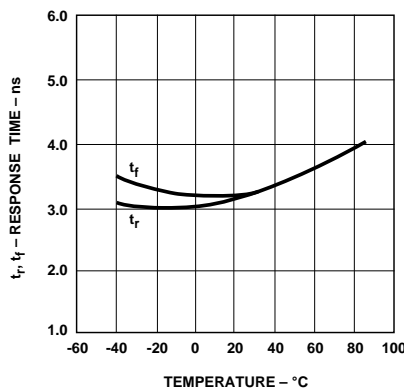

Figure 9. Typical Rise and Fall Times vs. Temperature.

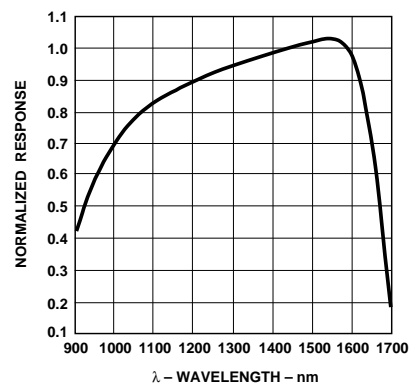

Figure 10. Normalized Receiver Spectral Response.

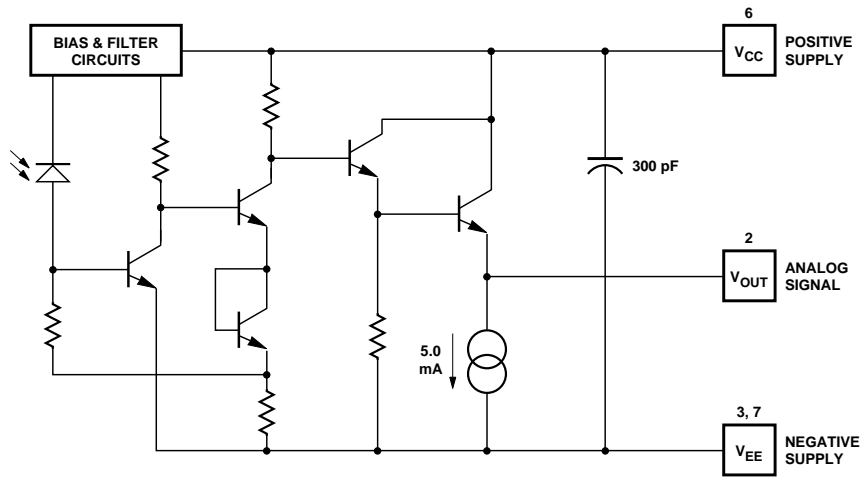
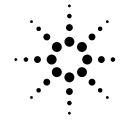

Figure 11. HFBR-2315T Simplified Schematic Diagram.



Agilent Technologies

Innovating the HP Way

www.semiconductor.agilent.com

Data subject to change.

Copyright © 1999 Agilent Technologies, Inc.

Obsoletes 5964-3544E (9/95)

5964-3544E (11/99)