



FLASH-ROM MODULE 2MByte (512K x32-Bit) –68-Pin JLCC
Part No. HMF51232J4V

GENERAL DESCRIPTION

The HMF51232J4V is a high-speed flash read only memory (FROM) module containing 524,288 words organized in a x32bit configuration. The module consists of four 512Kx 8 FROM mounted on a 68-pin, JLCC FR4-printed circuit board. Commands are written to the command register using standard microprocessor write timings. Register contents serve as input to an internal state-machine, which controls the erase and programming circuitry. Write cycles also internally latch addresses and data needed for the programming and erase operations. Reading data out of the device is similar to reading from 12.0V flash or EPROM devices. Four chip enable inputs, (/CE1, /CE2, /CE3, /CE4) are used to enable the module 's 4 bytes independently. Output enable (/OE) and write enable (/WE) can set the memory input and output. When FROM module is disable condition, the module is becoming power standby mode, system designer can get low -power design. All module components may be powered from a single +3.3V DC power supply and all inputs and outputs are LVTTTL-compatible.

FEATURES

- w Access time : 55,70, 90 and 120ns
- w High-density 2MByte design
- w High-reliability, low-power design
- w Single + 3V ± 0.3V power supply
- w Easy memory expansion
- w All inputs and outputs are TTL-compatible
- w FR4-PCB design
- w Low profile 68-pin JLCC
- w Minimum 1,000,000 write/erase cycle
- w Sector erases architecture
- w Sector group protection
- w Temporary sector group unprotection
- w The used device is Am29LV040B

OPTIONS

- w Timing
- 55ns access
- 70ns access
- 90ns access
- 120ns access

MARKING

- 55
- 70
- 90
- 120
- J

PIN ASSIGNMENT

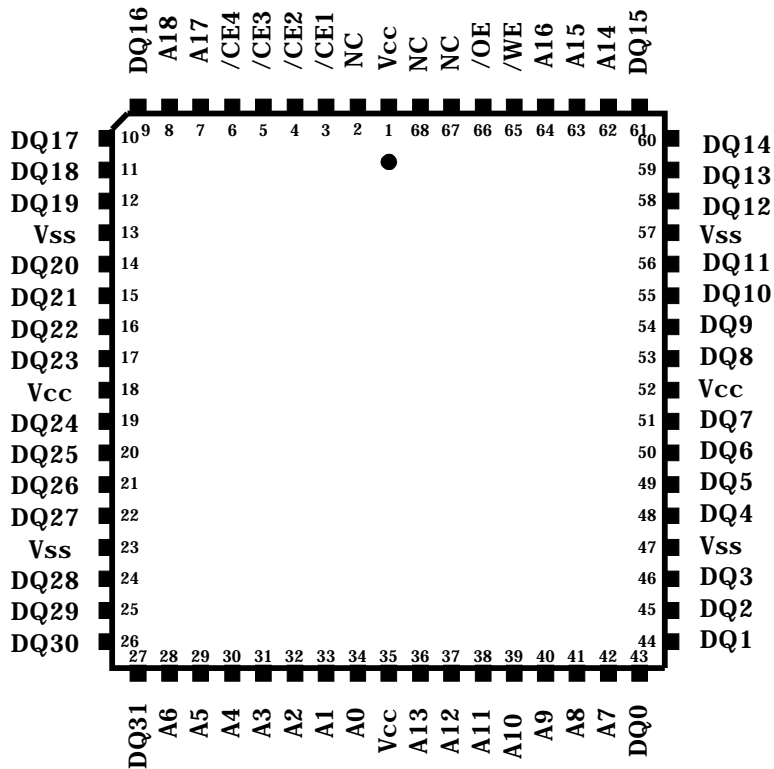

**68-pin JLCC
TOP VIEW**

FUNCTIONAL BLOCK DIAGRAM

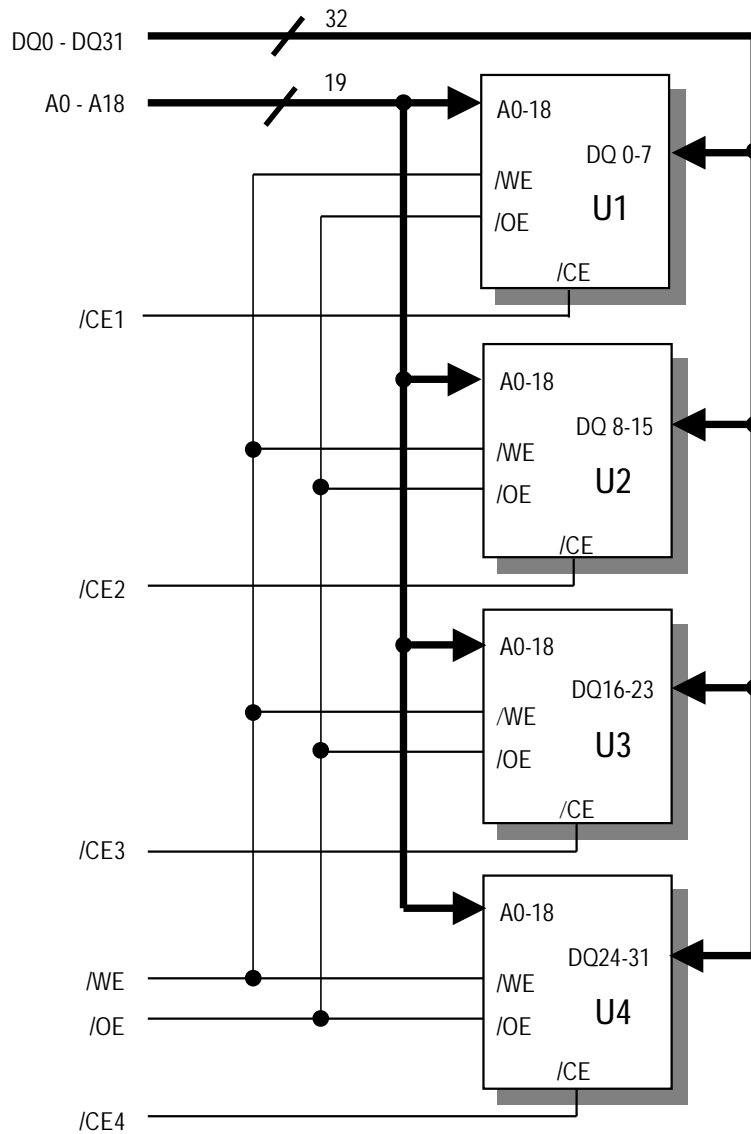

TRUTH TABLE

MODE	/CE	/OE	/WE	DQ	ADDRESSES
READ	L	L	H	DOUT	AIN
WRITE	L	H	L	DIN	AIN
STANDBY	V _{cc} ±0.3V	X	X	HIGH-Z	X
OUTPUT DISABLE	L	H	H	HIGH-Z	X
Reset	X	X	X	HIGH-Z	X
Sector Protect	L	H	L	DIN,DOUT	Sector Address, A6=L,A1=H,A0=L

Sector Unprotect	L	H	L	DIN,DOUT	Sector Address, A6=L,A1=H,A0=L
Temporary Sector Unprotect	X	X	X	DIN	AIN

Note : X means don't care

ABSOLUTE MAXIMUM RATINGS

PARAMETER	SYMBOL	RATING
Voltage with respect to ground all other pins	$V_{IN,OUT}$	-0.5V to $V_{CC} + 0.5V$
Voltage with respect to ground V_{CC}	V_{CC}	-0.5V to +4.0V
Storage Temperature	T_{STG}	-65°C to +150°C
Operating Temperature	T_A	-55°C to +125°C

w Stresses greater than those listed under " Absolute Maximum Ratings" may cause permanent damage to the device. This is a stress rating only and functional operation of the device at these or any other conditions above those indicated in the operating section of this specification is not implied. Exposure to absolute maximum rating conditions for extended periods may affect reliability.

RECOMMENDED DC OPERATING CONDITIONS

PARAMETER	SYMBOL	MIN	TYP.	MAX
V_{CC} for regulated voltage range	V_{CC}	3.0V		3.6V
V_{CC} for full voltage range	V_{CC}	2.7V		3.6V
Ground	V_{SS}	0	0	0

DC AND OPERATING CHARACTERISTICS ($0^{\circ}C \leq T_A \leq 70^{\circ}C$; $V_{CC} = 5V \pm 0.5V$)

PARAMETER	TEST CONDITIONS	SYMBOL	MIN	MAX	UNITS
Input Leakage Current	$V_{CC}=V_{CC} \text{ max}, V_{IN}= \text{GND to } V_{CC}$	I_{L1}		± 1.0	μA
Output Leakage Current	$V_{CC}=V_{CC} \text{ max}, V_{OUT}= \text{GND to } V_{CC}$	I_{L0}		± 1.0	μA
Output High Voltage	$I_{OH} = -2.0\text{mA}, V_{CC} = V_{CC} \text{ min}$	V_{OH}	0.85 V_{CC}		V
Output Low Voltage	$I_{OL} = 4.0\text{mA}, V_{CC} = V_{CC} \text{ min}$	V_{OL}		0.45	V
V_{CC} Active Current for Read(1)	$/CE = V_{IL}, /OE = V_{IH}, f = 5\text{MHz}$	I_{CC1}		12	mA
V_{CC} Active Current for Program or Erase(2)	$/CE = V_{IL}, /OE = V_{IH}$	I_{CC2}		30	mA
V_{CC} Standby Current	$/CE = V_{CC} \pm 0.3V$	I_{CC3}		5	mA
V_{CC} Reset Current		I_{CC4}		5	mA
Low V_{CC} Lock-Out Voltage		V_{LKO}	2.3	2.5	V

Notes:

1. The I_{CC} current listed is typically less than than 2mA/MHz, with $/OE$ at V_{IH} . Typical V_{CC} is 3.0V
2. I_{CC} active while embedded algorithm (program or erase) is in progress
3. Maximum I_{CC} current specifications are tested with $V_{CC}=V_{CC} \text{ max}$

ERASE AND PROGRAMMING PERFORMANCE

PARAMETER	LIMITS			UNIT	COMMENTS
	MIN.	TYP.	MAX.		
Sector Erase Time	-	1.7	15	sec	Excludes 00H programming prior to erasure
Byte Programming Time	-	9	300	us	Excludes system-level overhead
Chip Programming Time	-	4.5	13.5	sec	Excludes system-level overhead

CAPACITANCE

PARAMETER SYMBOL	PARAMETER DESCRIPTION	TEST SETUP	TYP.	MAX	UNIT
C _{IN}	Input Capacitance	V _{IN} = 0	6	7.5	pF
C _{OUT}	Output Capacitance	V _{OUT} = 0	8.5	12	pF
C _{IN2}	Control Pin Capacitance	V _{IN} = 0	7.5	9	pF

Notes : Test conditions T_A = 25°C, f=1.0 MHz.

AC CHARACTERISTICS**u Read Only Operations Characteristics**

PARAMETER SYMBOLS		DESCRIPTION	TEST SETUP		-55	-90	UNIT
JEDEC	STANDARD						
t _{AVAV}	t _{RC}	Read Cycle Time		Min	55	90	ns
t _{AVQV}	t _{ACC}	Address to Output Delay	/CE = V _{IL} /OE = V _{IL}	Max	55	90	ns
t _{ELQV}	t _{CE}	Chip Enable to Output Delay	/OE = V _{IL}	Max	55	90	ns
t _{GLQV}	t _{OE}	Chip Enable to Output Delay		Max	30	35	ns
t _{EHQZ}	t _{DF}	Chip Enable to Output High-Z		Max	25	30	ns
t _{GHQZ}	t _{DF}	Output Enable to Output High-Z		Max	25	30	ns
t _{AXQX}	t _{QH}	Output Hold Time From Addresses, /CE or /OE, Whichever Occurs First		Min	0	0	ns

Notes : Test Conditions : Output Load : 1TTL gate and 100 pF

Input rise and fall times : 5 ns

Input pulse levels : 0V to 3.0V

Timing measurement reference level

Input : 1.5V / Output : 1.5V

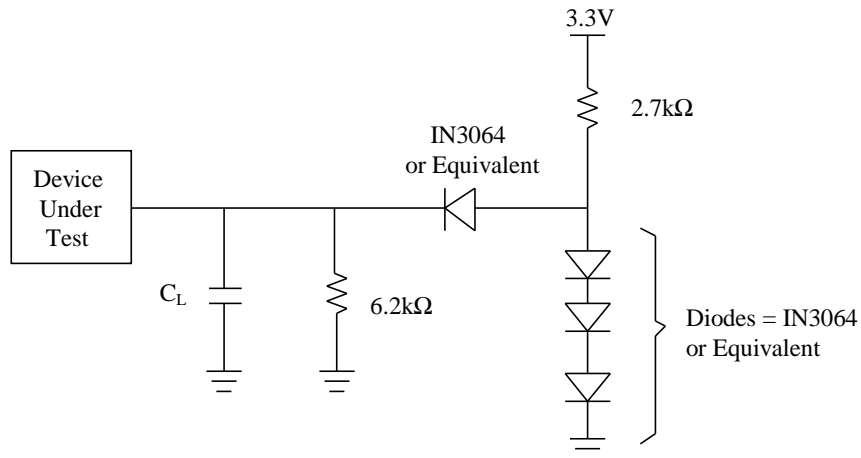

Note : $C_L = 100\text{pF}$ including jig capacitance

Write/Erase/Program Operations
Alternate /WE Controlled Writes

PARAMETER SYMBOLS		DESCRIPTION		-55	-90	UNIT
JEDEC	STANDARD					
t_{AVAV}	t_{WC}	Write Cycle Time	Min	55	90	ns
t_{AVWL}	t_{AS}	Address Setup Time	Min	0	0	ns
t_{WLAX}	t_{AH}	Address Hold Time	Min	45	45	ns
t_{DVWH}	t_{DS}	Data Setup Time	Min	35	45	ns
t_{WHDX}	t_{DH}	Data Hold Time	Min	0	0	ns
	t_{OES}	Output Enable Setup Time	Min	0	0	ns
t_{GHWL}	t_{GHWL}	Read Recover Time Before Write	Min	0	0	ns
t_{ELWL}	t_{CS}	/CE Setup Time	Min	0	0	ns
t_{WHEH}	t_{CH}	/CE Hold Time	Min	0	0	ns
t_{WLWH}	t_{WP}	Write Pulse Width	Min	35	35	ns
t_{WHWL}	t_{WPH}	Write Pulse Width High	Min	30	30	ns
t_{WHWH1}	t_{WHWH1}	Byte Programming Operation	Typ	9	9	μs
t_{WHWH2}	t_{WHWH2}	Sector Erase Operation (Note1)	Typ	0.7	0.7	sec
	t_{VCS}	Vcc Setup Time	Min	50	50	μs

Notes :

1. This does not include the preprogramming time
2. This timing is only for Sector Protect operations

Write/Erase/Program Operations

Alternate /CE Controlled Writes

PARAMETER SYMBOLS		DESCRIPTION		-55	-90	UNIT
JEDEC	STANDARD					
t _{AVAV}	t _{WC}	Write Cycle Time	Min	55	90	ns
t _{AVEL}	t _{AS}	Address Setup Time	Min	0	0	ns
t _{ELAX}	t _{AH}	Address Hold Time	Min	45	45	ns
t _{DVEH}	t _{DS}	Data Setup Time	Min	35	45	ns
t _{EHDx}	t _{DH}	Data Hold Time	Min	0	0	ns
	t _{OES}	Output Enable Setup Time	Min	0	0	ns
t _{GHEL}	t _{GHEL}	Read Recover Time Before Write	Min	0	0	ns
t _{WLEL}	t _{WS}	/WE Setup Time	Min	0	0	ns
t _{EHWH}	t _{WH}	/WE Hold Time	Min	0	0	ns
t _{ELEH}	t _{CP}	/CE Pulse Width	Min	35	35	ns
t _{EHEL}	t _{CPH}	/CE Pulse Width High	Min	30	30	ns
t _{WHWH1}	t _{WHWH1}	Byte Programming Operation	Typ	9	9	μs
t _{WHWH2}	t _{WHWH2}	Sector Erase Operation (Note)	Typ	0.7	0.7	sec

Notes : This does not include the preprogramming time.

u READ OPERATIONS TIMING

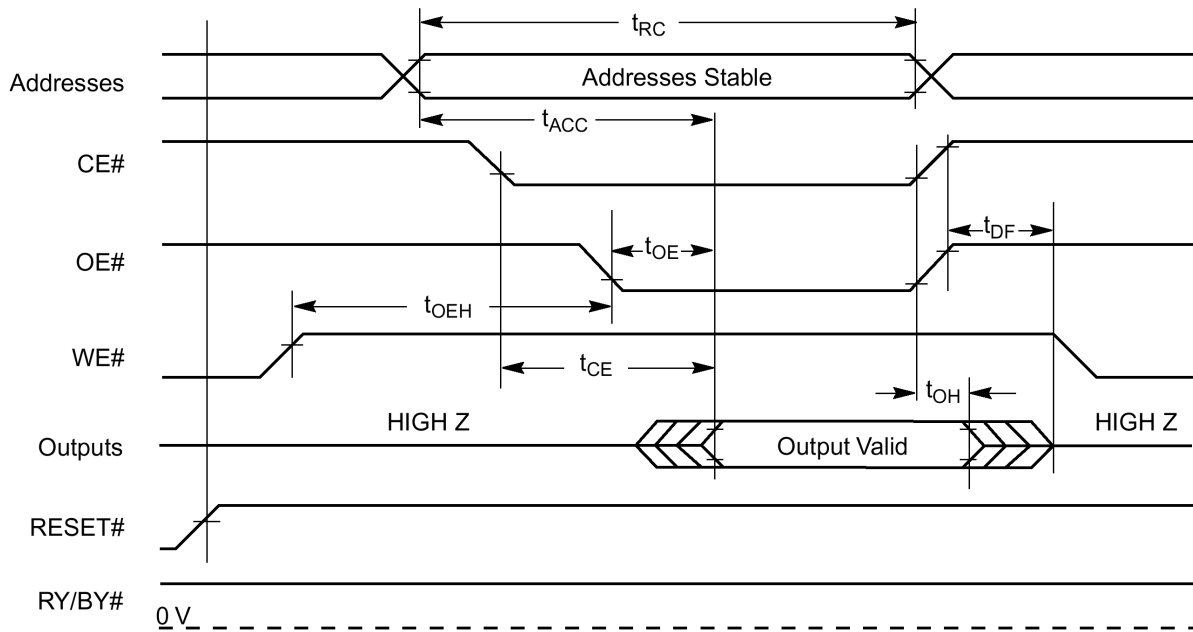

u RESET TIMING

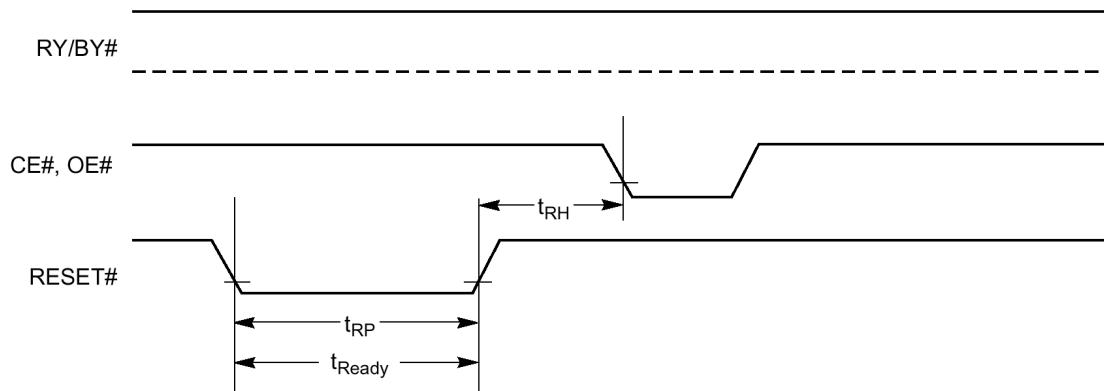

Reset Timings NOT during Embedded Algorithms

Reset Timings during Embedded Algorithms

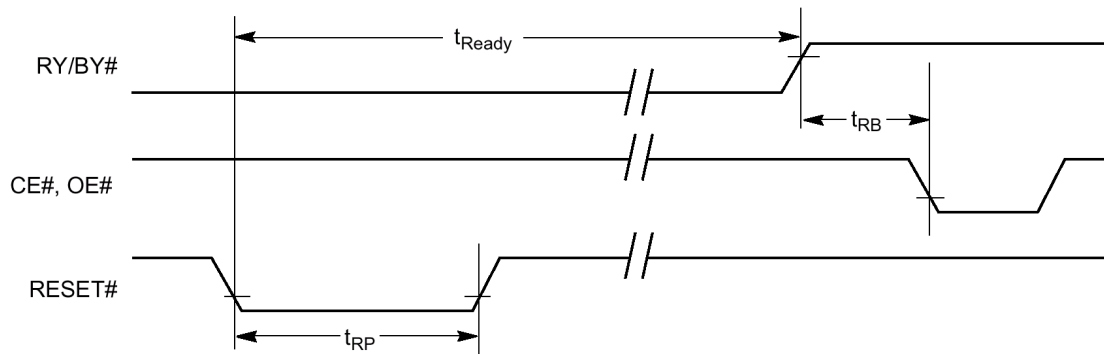

U PROGRAM OPERATIONS TIMING

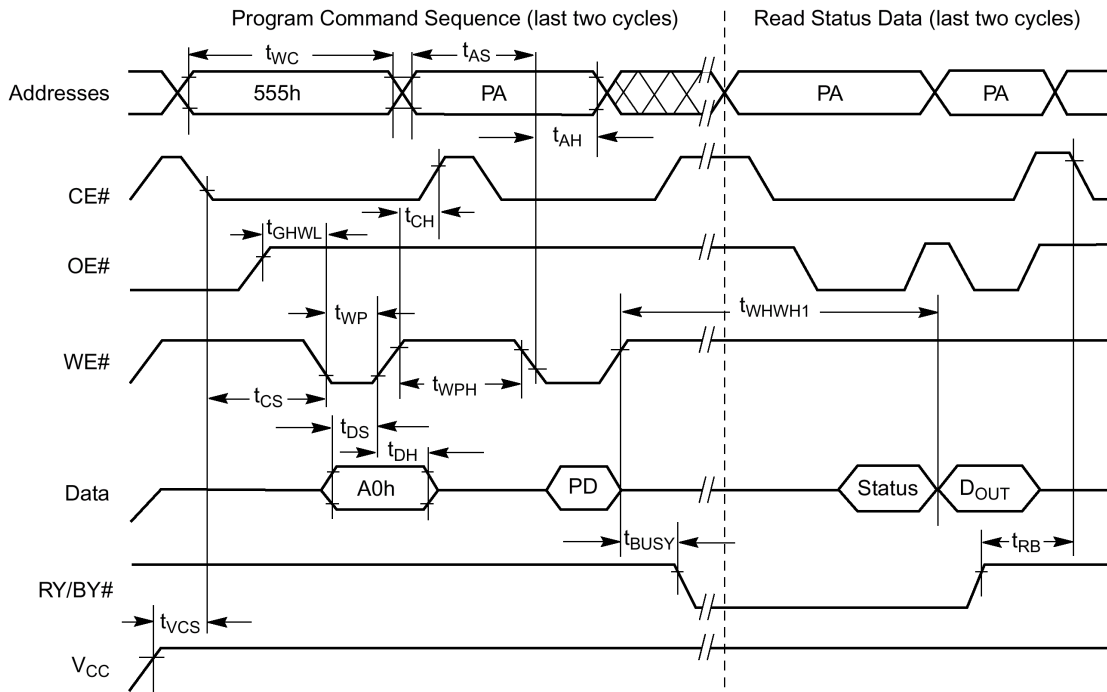

U CHIP/SECTOR ERASE OPERATION TIMINGS

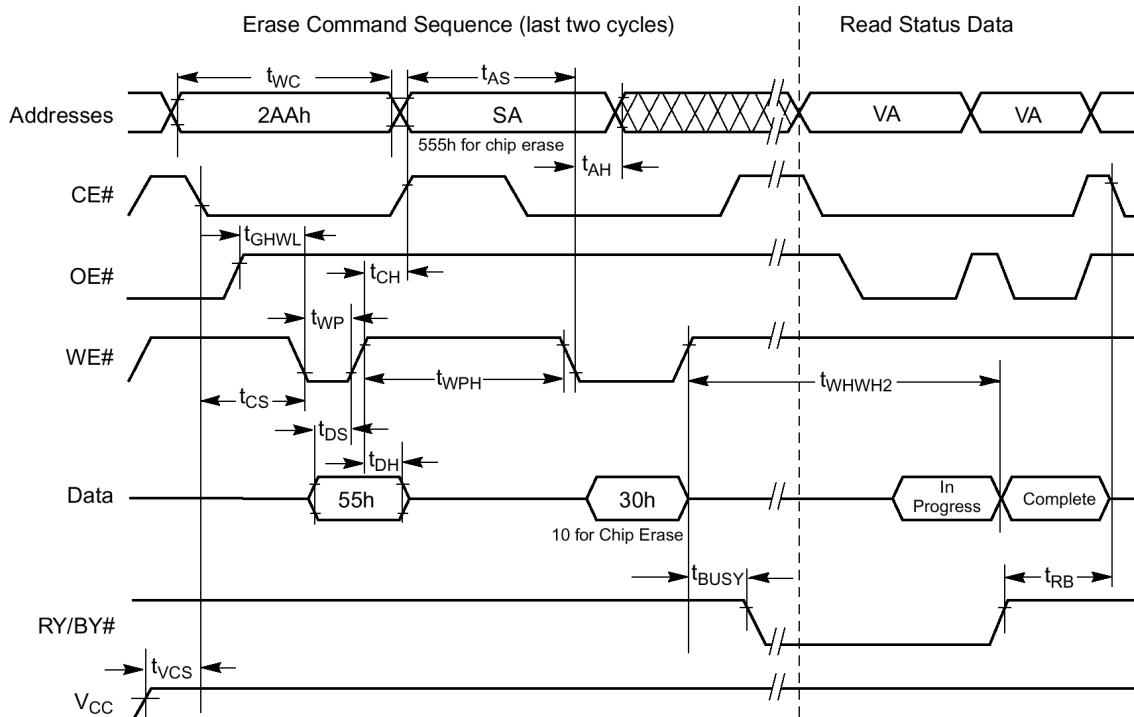

DATA# POLLING TIMES(DURING EMBEDDED ALGORITHMS)

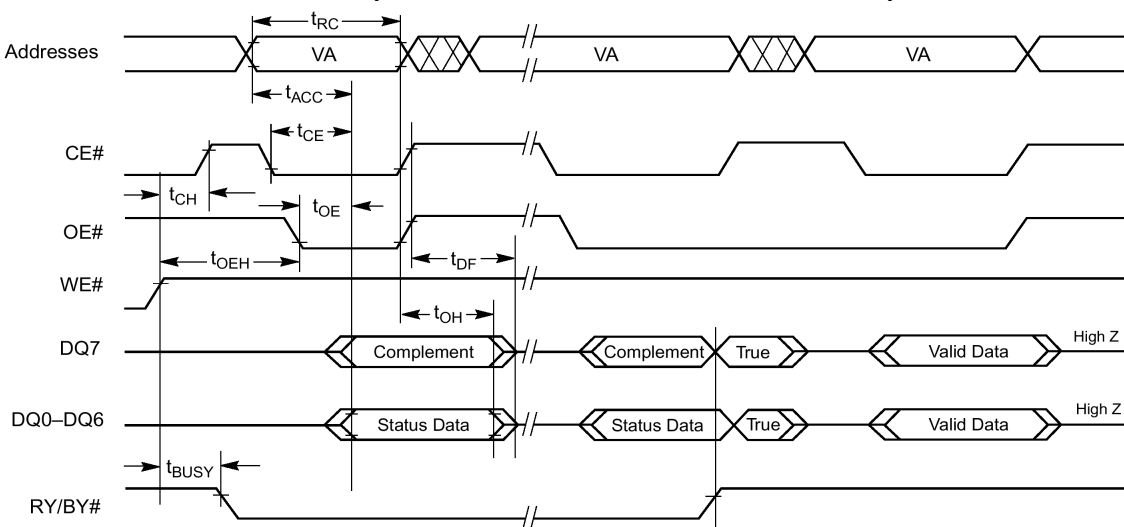

TOGGLE# BIT TIMINGS (DURING EMBEDDED ALGORITHMS)

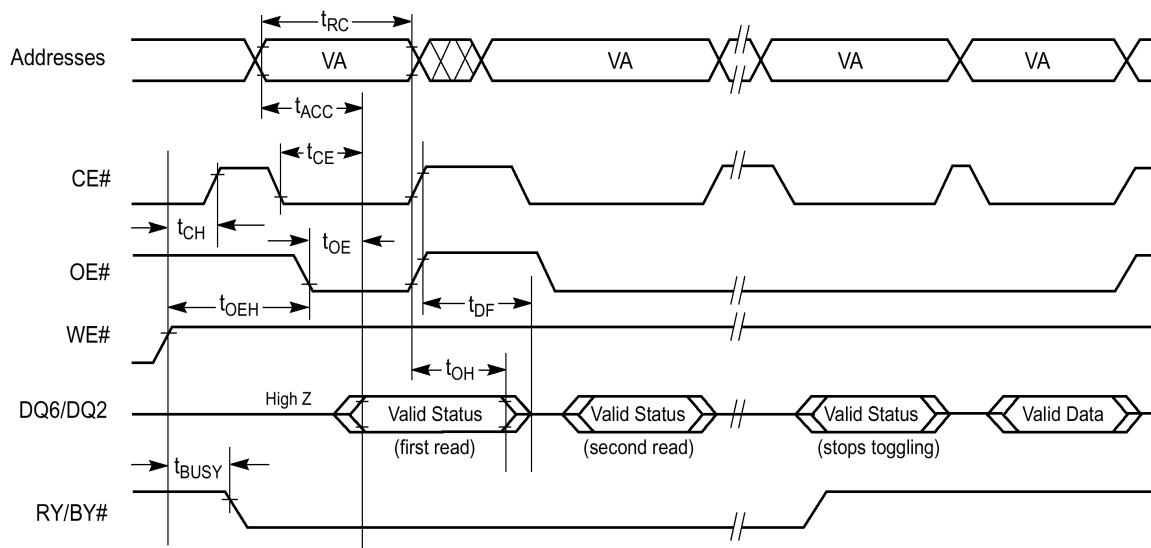

U SECTOR PROTECT UNPROTECT TIMEING DIAGRAM

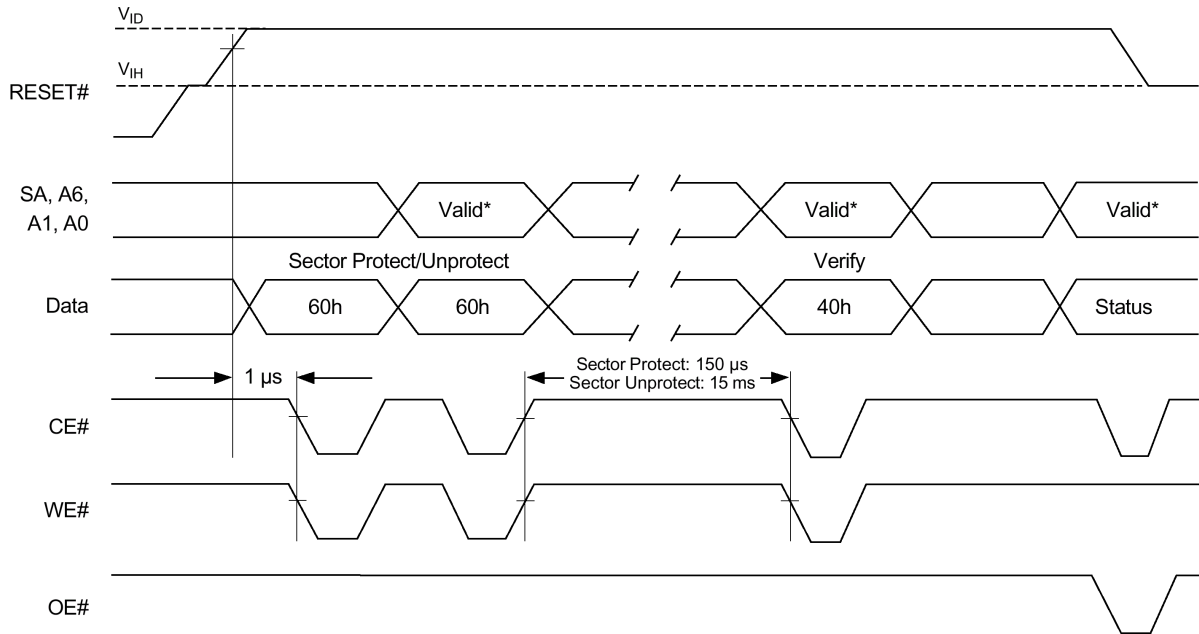

U ALTERNATE CE# CONTROLLED WRITE OPERATING TIMINGS

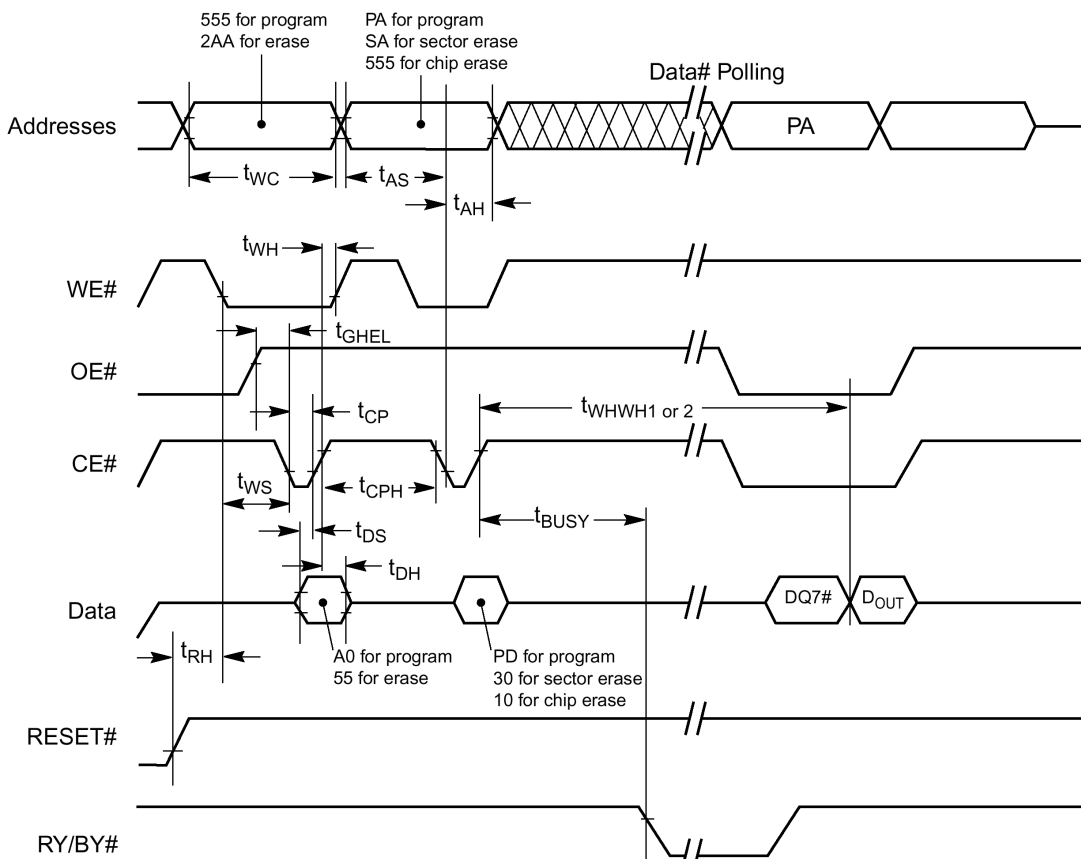

PACKAGE DIMENSIONS

68-Pin JLCC

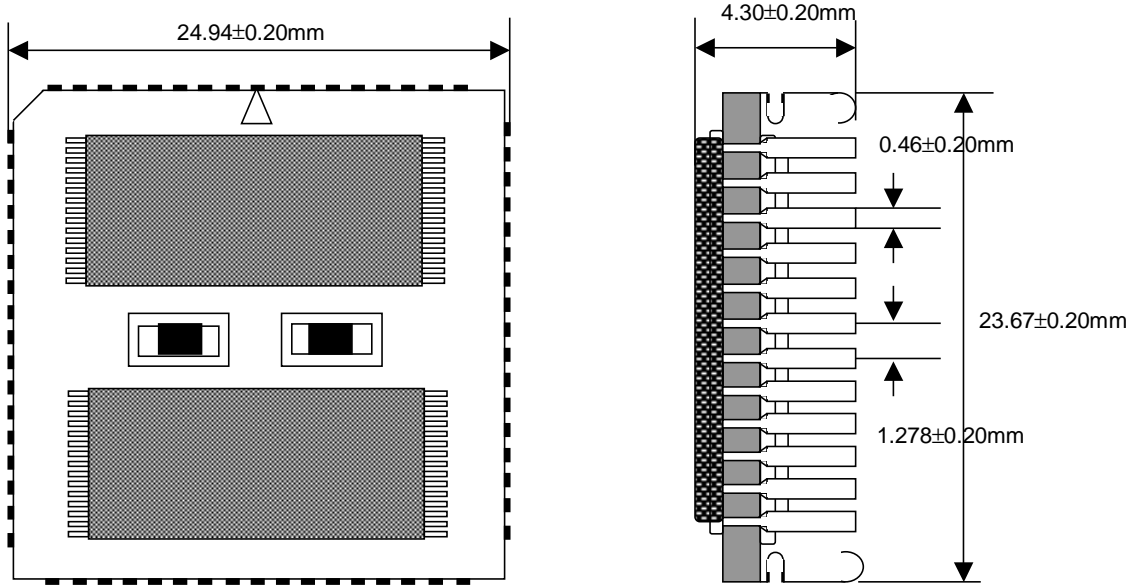

ORDERING INFORMATION

Part Number	Density	Org.	Package	Component Number	Vcc	SPEED
HMF51232J4V-55	2MByte	512k×32bit	68Pin-JLCC	4EA	3.3V	55ns
HMF51232J4V-70	2MByte	512k×32bit	68 Pin-JLCC	4EA	3.3V	70ns
HMF51232J4V-90	2MByte	512k×32bit	68 Pin-JLCC	4EA	3.3V	90ns
HMF51232J4V-120	2MByte	512k×32bit	68 Pin-JLCC	4EA	3.3V	120ns