



SANYO Semiconductors

DATA SHEET

LA1845NV — Monolithic Linear IC

Single-Chip Home Stereo IC

The LA1845NV is designed for use in mini systems and is a single-chip tuner IC that provides electronic tuning functions using SD/IF-count technique. It incorporates a pilot canceler and an adjustment-free MUX VCO circuit, thus allows additional parts to be reduced.

Functions

- AM : RF amplifier, mixer, oscillator, IF amplifier, detector, AGC, SD, oscillator buffer, IF buffer, stereo IF output, AGC time constant switch
- FM IF : IF amplifier, quadrature detector, S-meter, SD (signal detection), S-curve detection, IF buffer output
- MPX : PLL stereo decoder, stereo display, forced monaural, VCO stop, audio muting, adjacent channel interference rejection function, pilot canceler

Features

- Integrated MPX VCO (ceramic resonators are no longer required.)
- Built-in adjacent channel interference rejection function (114kHz, 190kHz)
- Supports both SD and IF-count techniques
- Both FM SD sensitivity and bandwidth can be set
- Pilot canceler built in.

Maximum Ratings at Ta = 25°C

Parameter	Symbol	Conditions	Ratings	Unit
Maximum Power Supply Voltage	V _{CC} max		6	V
Allowable Power Consumption	P _d max	Ta = 80°C with board 114.3mm×76.1mm×1.6mm material : Glass epoxy resin	360	mW
Operating Temperature	T _{opr}		-20 to +80	°C
Storage Temperature	T _{stg}		-40 to +125	°C

Operating Conditions at Ta = 25°C

Parameter	Symbol	Conditions	Ratings	Unit
Recommended Supply Voltage	V _{CC}		5	V
Operating Supply Voltage Range	V _{CC} op	Ta = 80°C	4.3 to 5.5	V

■ Any and all SANYO Semiconductor products described or contained herein do not have specifications that can handle applications that require extremely high levels of reliability, such as life-support systems, aircraft's control systems, or other applications whose failure can be reasonably expected to result in serious physical and/or material damage. Consult with your SANYO Semiconductor representative nearest you before using any SANYO Semiconductor products described or contained herein in such applications.

■ SANYO Semiconductor assumes no responsibility for equipment failures that result from using products at values that exceed, even momentarily, rated values (such as maximum ratings, operating condition ranges, or other parameters) listed in products specifications of any and all SANYO Semiconductor products described or contained herein.

SANYO Semiconductor Co., Ltd.

TOKYO OFFICE Tokyo Bldg., 1-10, 1 Chome, Ueno, Taito-ku, TOKYO, 110-8534 JAPAN

LA1845NV

Electrical Characteristics • Operating Characteristics at $V_{CC} = 8V$, in the specified test circuit.

FM Mono Characteristics at $f_c = 10.7MHz$, $V_i = 100dB\mu$, $f_m = 1kHz$, Modulation = 75kHz

Parameter	Conditions	Ratings			Unit
		min	typ	max	
Current Drain	With no input signal	20	30	40	mA
Demodulator Output	100dB μ , 100% modulation, $f_m = 1kHz$	230	360	460	mVrms
Total Harmonic Distortion	100dB μ , 100% modulation, $f_m = 1kHz$		0.35	1.5	%
Signal-to-Noise Ratio	100dB μ , 100% modulation, $f_m = 1kHz$	73	80		dB
AM Rejection Ratio	100dB μ , AM = 30% modulation, $f_m = 1kHz$	47	65		dB
3dB Sensitivity	100dB μ , 100% modulation, $f_m = 1kHz$ Output reference, -3dB input		32	40	dB μ
SD Sensitivity	0% modulation	38	47	56	dB μ
IF Counter Buffer Output	100dB μ	200	275	400	mVrms
Mute Attenuation	100dB μ , 100% modulation, $f_m = 1kHz$		76		dB

FM Stereo Characteristics at $f_c = 10.7MHz$, $V_i = 100dB\mu$, L+R = 90%, Pilot = 10%, $f_m = 1kHz$

Parameter	Conditions	Ratings			Unit
		min	typ	max	
Separation	L+R = 90%, Pilot = 10%, $f_m = 1kHz$	30	42		dB
Stereo On Level	Pilot input	1.5	3.5	5.5	%
Total Harmonic Distortion	Pilot input		0.45	1.5	%
Adjacent Channel Rejection Ratio 1	$f_s = 113kHz$, VS = 90%, Pilot = 10% ; The left-right modulation, demodulated output		36		dB
Adjacent Channel Rejection Ratio 2	$f_s = 189kHz$, VS = 90%, Pilot = 10% ; The left-right modulation, demodulated output		41		dB
Carrier Leak	L+R = 90%, Pilot = 10% reference, Pilot = 10% output	38	44		dB

AM Characteristics at $f_c = 1000kHz$, $V_i = 80dB\mu$, $f_m = 1kHz$, Modulation = 30%

Parameter	Conditions	Ratings			Unit
		min	typ	max	
Current Drain	With no input signal	13	27	39	mA
Detector Output 1	23dB μ , 30% modulation, $f_m = 1kHz$	40	80	160	mVrms
Detector Output 2	80dB μ , 30% modulation, $f_m = 1kHz$	90	160	230	mVrms
Signal-to-Noise Ratio 1	23dB μ , 30% modulation, $f_m = 1kHz$	17	23		dB
Signal-to-Noise Ratio 2	80dB μ , 30% modulation, $f_m = 1kHz$	46	52		dB
Total Harmonic Distortion 1	80dB μ , 30% modulation, $f_m = 1kHz$		0.4	1.1	%
Total Harmonic Distortion 2	107dB μ , 30% modulation, $f_m = 1kHz$		0.5	1.3	%
SD Sensitivity	0% modulation	11	20	29	dB μ
Local Oscillator Buffer Output	With no input signal	100	140	200	mVrms
IF Counter Buffer Output	23dB μ	140	285	400	mVrms

LA1845NV

Package Dimensions

unit : mm
3175B

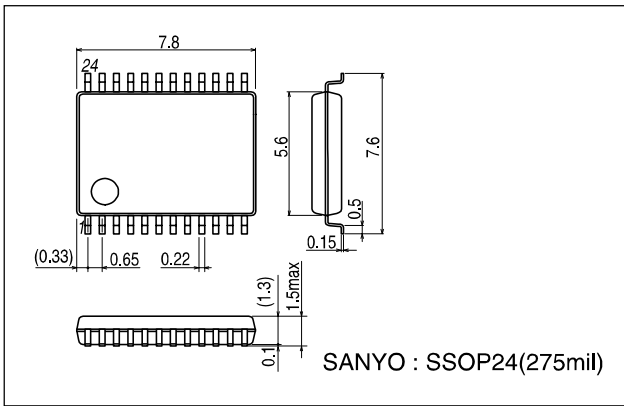

Pin Description

Pin No.	Pin function	Pin voltage	Equivalent circuit	Notes
1	FM IF input	Vreg		Input impedance $r_i = 330\Omega$
2	AM mixer output	V _{CC}		Connect the mixer coil between this pin and V _{CC}
3	REG	2.1		Vreg = 2.1V
4	AM IF input	Vreg		Input impedance $r_i = 2k\Omega$
5	GND	0V		
6	Tu-LED	V _{CC}		Active low Open collector
7	ST-LED/AF-IF output			
8	FM detector	V _{CC}		The 600BEAS-10471 (Toko Mfg. Co., Ltd.) is recommended for detector coil.
9	V _{CC}			

Continued on next page.

LA1845NV

Continued from preceding page.

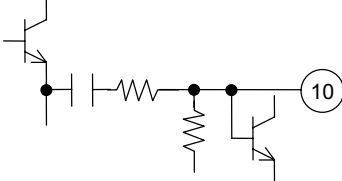
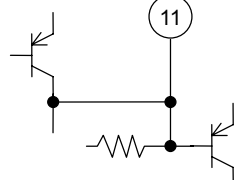
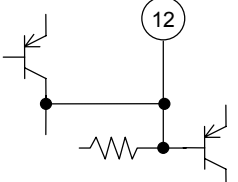
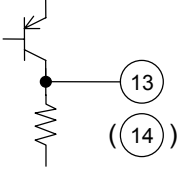
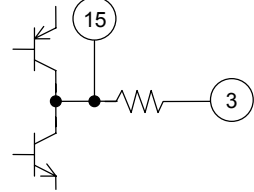
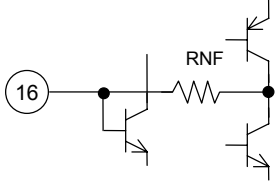
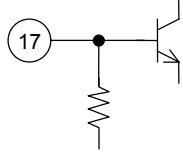
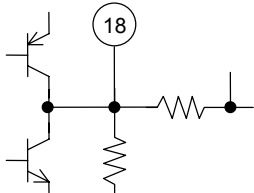
Pin No.	Pin function	Pin voltage	Equivalent circuit	Notes
10	AM/FM IF counter output, output control switch, mute switch	0V		$V_{10} \leq 0.5V$: Reception state $1.4V \leq V_{10} \leq 2.2V$: Muting on $V_{10} \geq 3.5V$: IF counter output and muting on
11	Phase comparator low-pass filter (AM/FM switching)	$V_{CC}-1.0$		The device operates in AM mode when a current of over $200\mu A$ flows from pin. 12.
12	Pilot detector low-pass filter (Forced mono) (VCO stop)	$V_{CC}-1.0$		The device is forced to monaural when a current of over $50\mu A$ flows from this pin. The VCO is stopped when a current of over $200\mu A$ flows from this pin. The limit values for the resistor are the same as those for pin 11.
13 14	L outputs R outputs	3.2V		Output impedance $r_o = 3.3k\Omega$
15	Pilot canceler output	Vreg		
16	Decoder input	Vreg		Inverting input pin $RNF = 20k\Omega$
17	PLL input	Vreg		Input impedance $r_i = 20k\Omega$
18	FM demodulator output	$V_{reg}+0.7$		Output impedance $r_o = 2.3k\Omega$ The channel separation can be adjusted with an external capacitor connected between this pin and ground.

Continued on next page.

LA1845NV

Continued from preceding page.

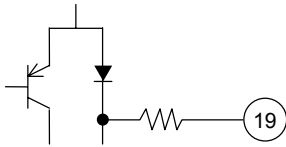
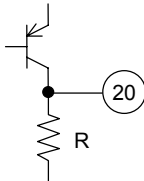
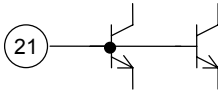
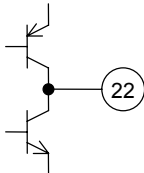
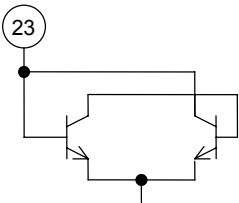
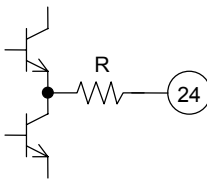
Pin No.	Pin function	Pin voltage	Equivalent circuit	Notes
19	AM detector output	0V (FM) 1.5V (AM)		Output impedance $r_o = 3.3k\Omega$
20	S meter, AM AGC	0.2V (FM) 0.9V (AM)		The resistance of the built-in resistor R is 13.9kΩ. The SD response during seek operation is determined with the external capacitor connected to this pin.
21	AM RF input	Vreg		Must be used at the same potential as pin 22.
22	AFC	Vreg		The FM SD bandwidth can be adjusted with the external resistor connected between this pin and pin 3 (Vreg).
23	OSC	V _{CC}		Connect the oscillator coil between this pin and pin 9 (V _{CC}). Note : Impedance of the secondary oscillator coil must be 5kΩ or higher.
24	Oscillator buffer output, FM SD sensitivity adjustment	V _{CC} -1.4		The FM SD sensitivity can be adjusted with an external resistor connected to this pin. Output impedance R = 200Ω Note : Resistance of the external resistor connected to the pin 24 must be 3.3kΩ or higher.

Equivalent Circuit Block Diagram

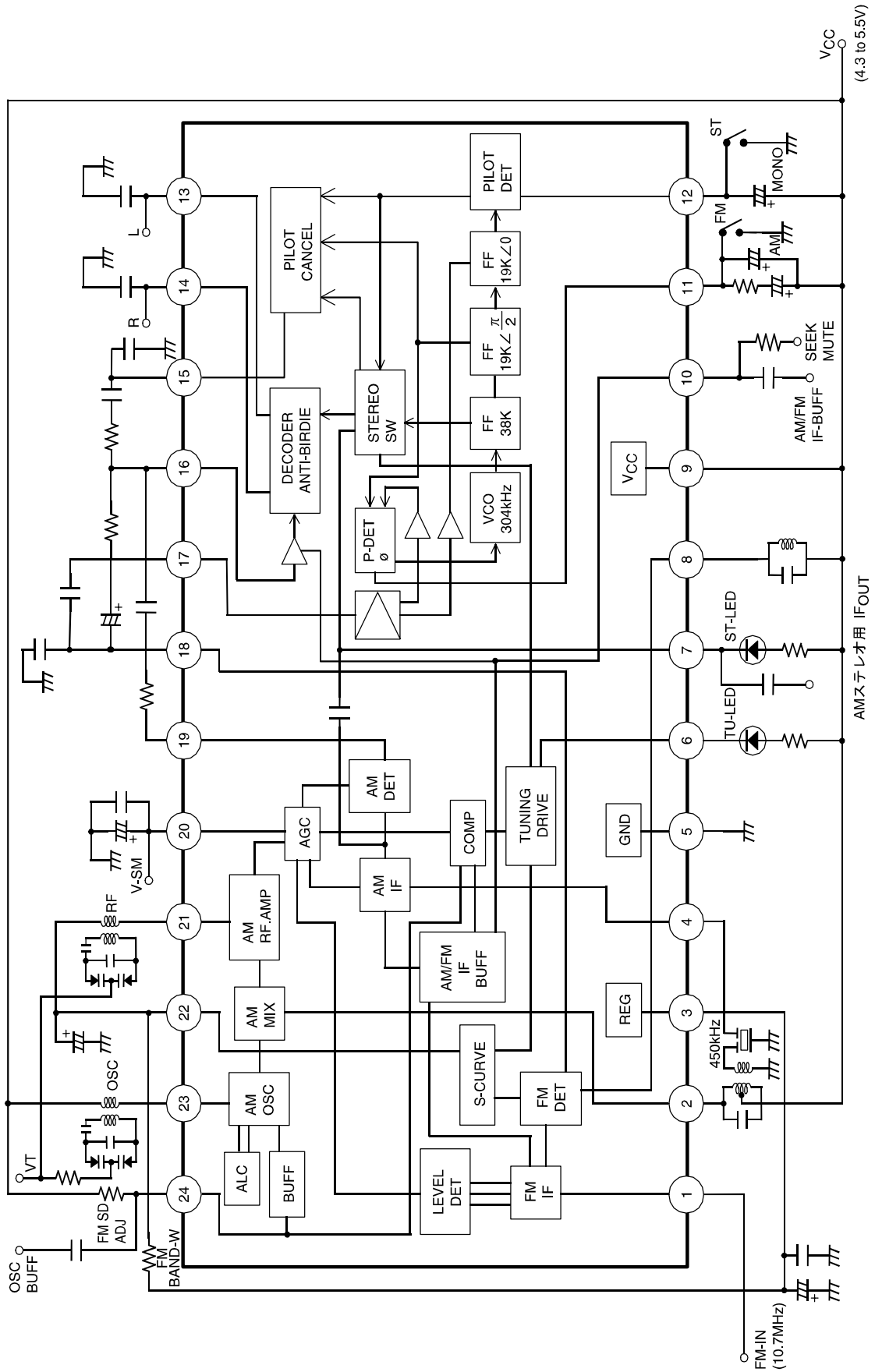

Top View

LA1845NV

Test Circuit

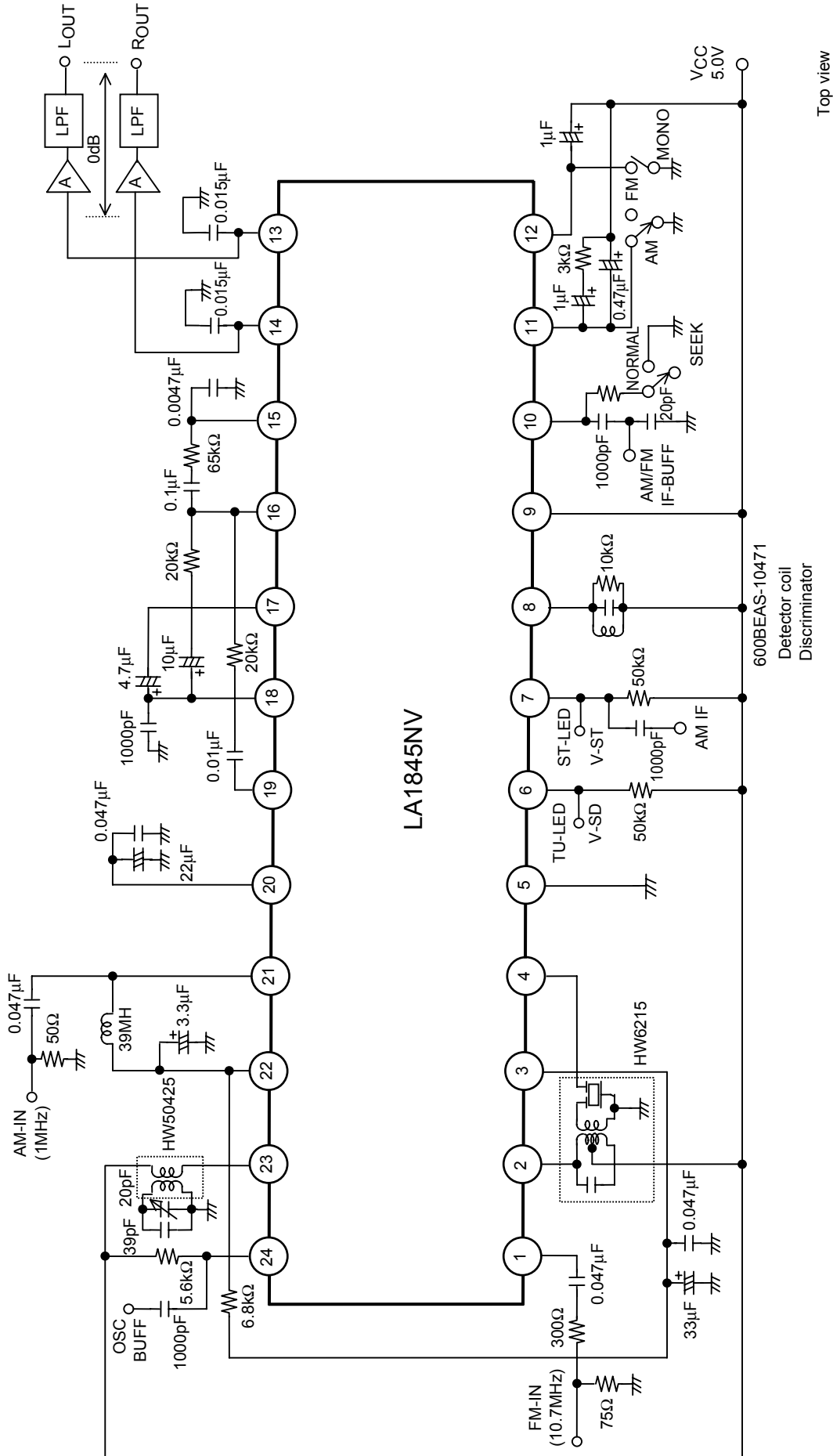

Top view

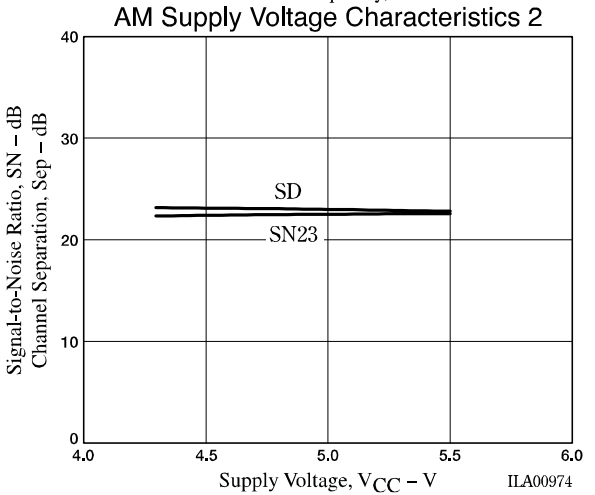
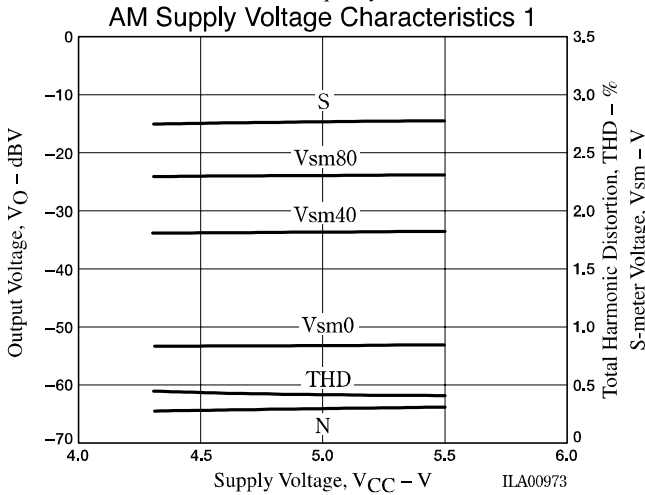
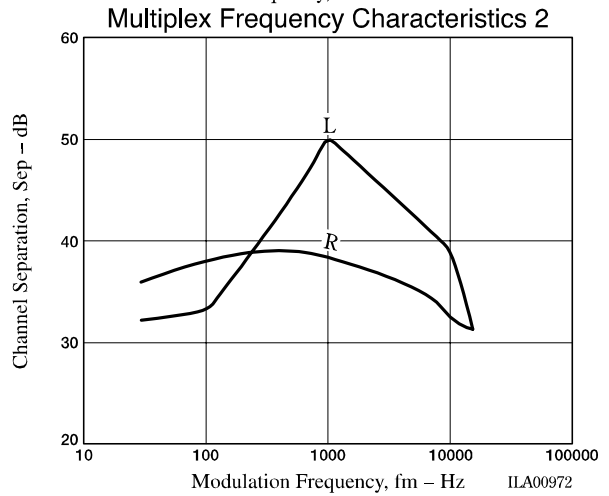
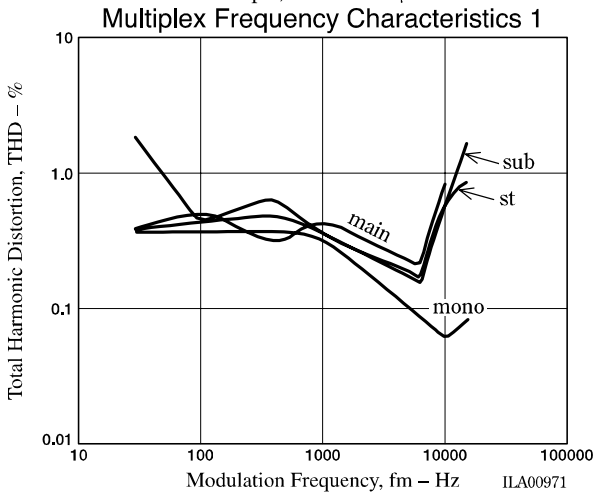
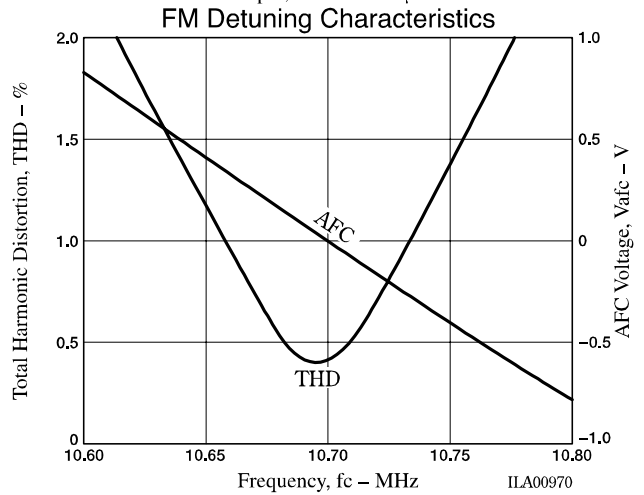
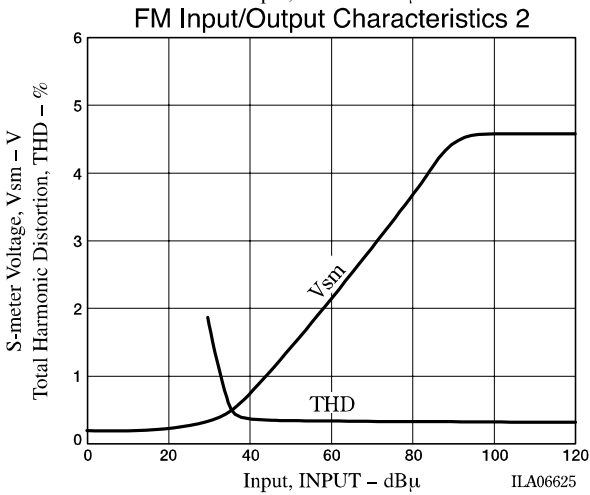
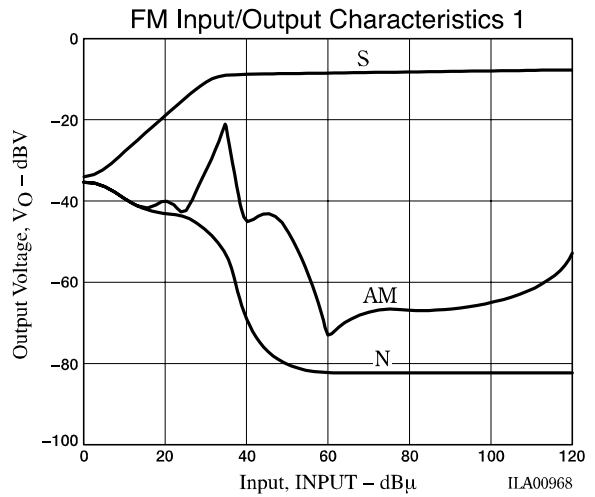
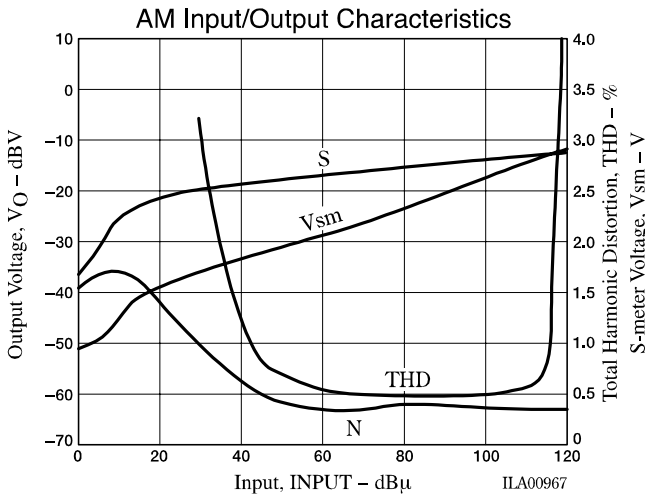

FM Supply Voltage Characteristics 1

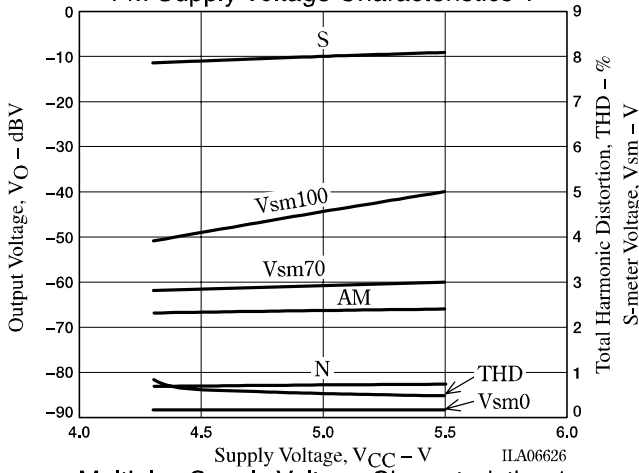

FM Supply Voltage Characteristics 2

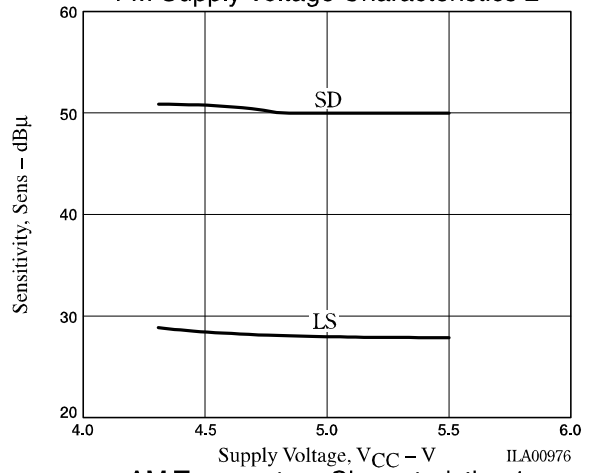

Multiplex Supply Voltage Characteristics 1

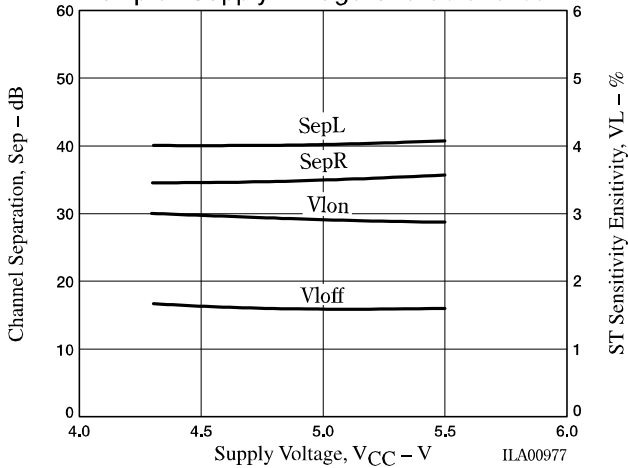

AM Temperature Characteristics 1

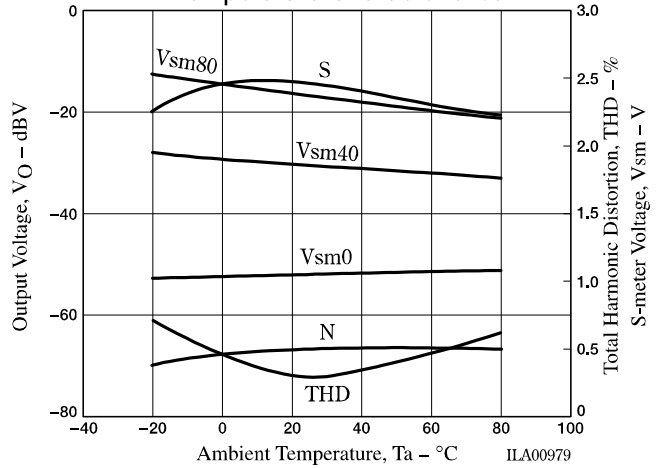

AM Temperature Characteristics 2

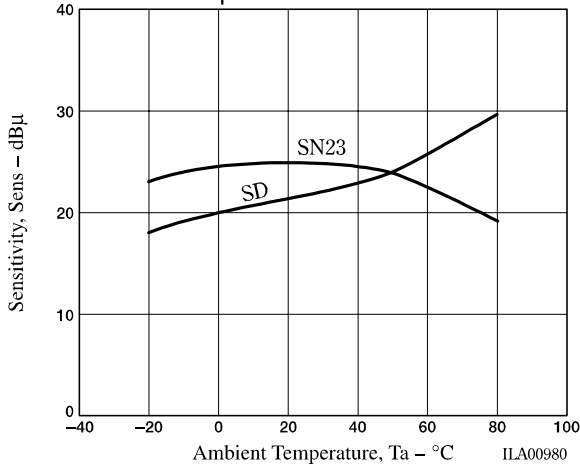

FM Temperature Characteristics 1

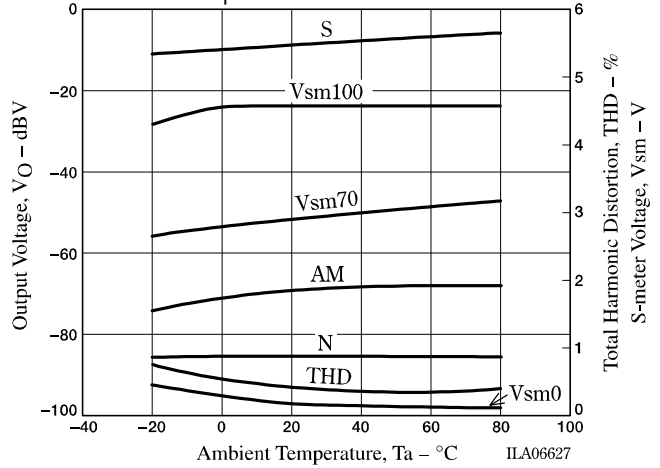

FM Temperature Characteristics 2

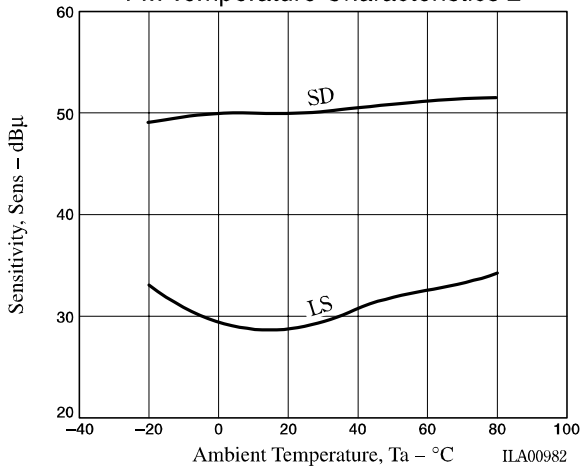

FM Temperature Characteristics 3

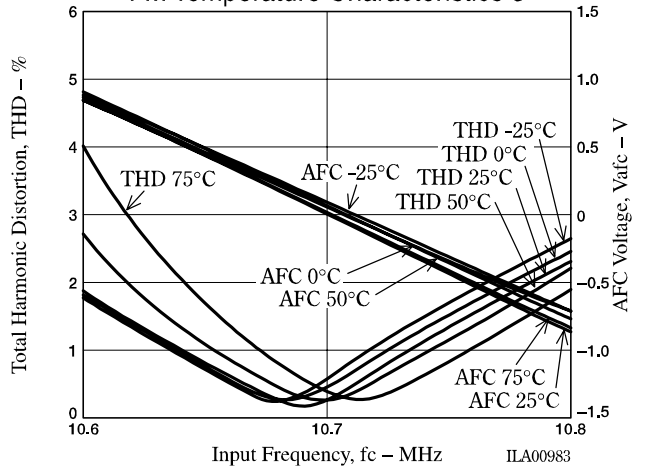

Multiplex Temperature Characteristics 1

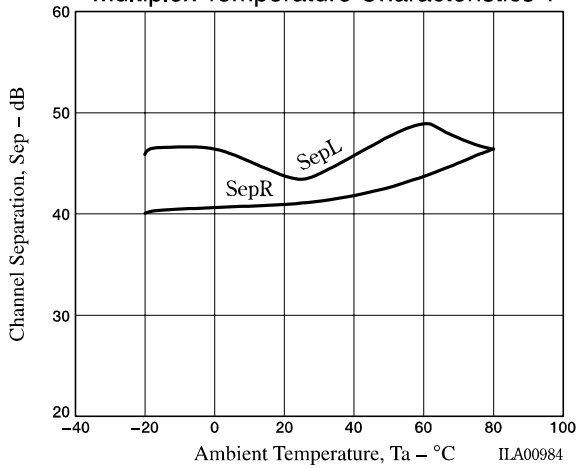

Multiplex Temperature Characteristics 2

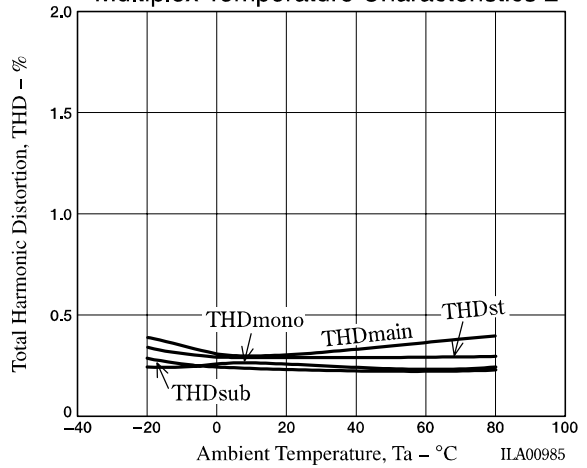

Multiplex Temperature Characteristics 3

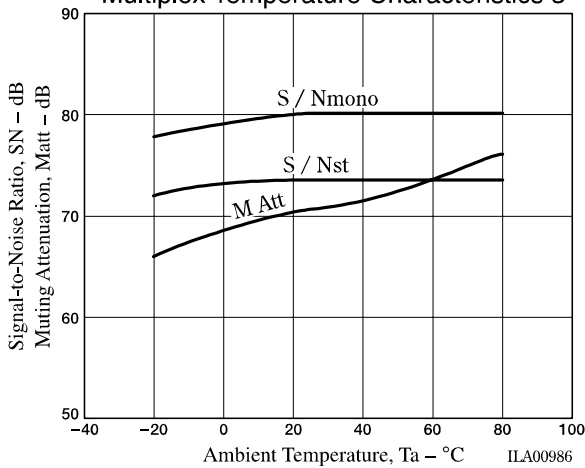

Multiplex Temperature Characteristics 4

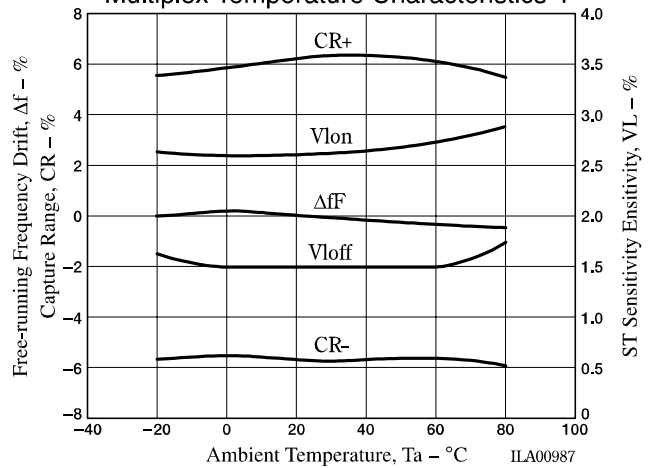

- Specifications of any and all SANYO Semiconductor products described or contained herein stipulate the performance, characteristics, and functions of the described products in the independent state, and are not guarantees of the performance, characteristics, and functions of the described products as mounted in the customer's products or equipment. To verify symptoms and states that cannot be evaluated in an independent device, the customer should always evaluate and test devices mounted in the customer's products or equipment.
- SANYO Semiconductor Co., Ltd. strives to supply high-quality high-reliability products. However, any and all semiconductor products fail with some probability. It is possible that these probabilistic failures could give rise to accidents or events that could endanger human lives, that could give rise to smoke or fire, or that could cause damage to other property. When designing equipment, adopt safety measures so that these kinds of accidents or events cannot occur. Such measures include but are not limited to protective circuits and error prevention circuits for safe design, redundant design, and structural design.
- In the event that any or all SANYO Semiconductor products (including technical data, services) described or contained herein are controlled under any of applicable local export control laws and regulations, such products must not be exported without obtaining the export license from the authorities concerned in accordance with the above law.
- No part of this publication may be reproduced or transmitted in any form or by any means, electronic or mechanical, including photocopying and recording, or any information storage or retrieval system, or otherwise, without the prior written permission of SANYO Semiconductor Co., Ltd.
- Any and all information described or contained herein are subject to change without notice due to product/technology improvement, etc. When designing equipment, refer to the "Delivery Specification" for the SANYO Semiconductor product that you intend to use.
- Information (including circuit diagrams and circuit parameters) herein is for example only; it is not guaranteed for volume production. SANYO Semiconductor believes information herein is accurate and reliable, but no guarantees are made or implied regarding its use or any infringements of intellectual property rights or other rights of third parties.

This catalog provides information as of September, 2004. Specifications and information herein are subject to change without notice.