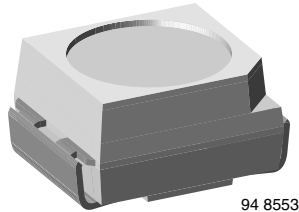


Infrared Emitting Diode, 950 nm, GaAs



94 8553

DESCRIPTION

VSMS3700 is an infrared, 950 nm emitting diode in GaAs technology, molded in a PLCC-2 package for surface mounting (SMD).

FEATURES

- Package type: surface mount
- Package form: PLCC-2
- Dimensions (L x W x H in mm): 3.5 x 2.8 x 1.75
- Peak wavelength: $\lambda_p = 950$ nm
- High reliability
- Angle of half intensity: $\varphi = \pm 60^\circ$
- Low forward voltage
- Suitable for high pulse current operation
- Good spectral matching with Si photodetectors
- Package matched with IR emitter series VEMT3700
- Floor life: 168 h, MSL 3, acc. J-STD-020
- Lead (Pb)-free reflow soldering
- AEC-Q101 qualified
- Compliant to RoHS directive 2002/95/EC and in accordance to WEEE 2002/96/EC
- Find out more about Vishay's Automotive Grade Product requirements at: www.vishay.com/applications

 AUTOMOTIVE
GRADE

RoHS
COMPLIANT

GREEN
[5-2008]**

APPLICATIONS

- Infrared source in tactile keyboards
- IR diode in low space applications
- PCB mounted infrared sensors
- Emitter in miniature photo-interrupters

PRODUCT SUMMARY

| COMPONENT | I_e (mW/sr) | φ (deg) | λ_p (nm) | t_r (ns) |
|-----------|---------------|-----------------|------------------|------------|
| VSMS3700 | 4.5 | ± 60 | 950 | 800 |

Note

Test conditions see table "Basic Characteristics"

ORDERING INFORMATION

| ORDERING CODE | PACKAGING | REMARKS | PACKAGE FORM |
|---------------|---------------|------------------------------|--------------|
| VSMS3700-GS08 | Tape and reel | MOQ: 7500 pcs, 1500 pcs/reel | PLCC-2 |
| VSMS3700-GS18 | Tape and reel | MOQ: 8000 pcs, 8000 pcs/reel | PLCC-2 |

Note

MOQ: minimum order quantity

** Please see document "Vishay Material Category Policy": www.vishay.com/doc?99902

| ABSOLUTE MAXIMUM RATINGS | | | | |
|-------------------------------------|-----------------------------------|------------|---------------|-------------|
| PARAMETER | TEST CONDITION | SYMBOL | VALUE | UNIT |
| Reverse voltage | | V_R | 5 | V |
| Forward current | | I_F | 100 | mA |
| Peak forward current | $t_p/T = 0.5$, $t_p = 100 \mu s$ | I_{FM} | 200 | mA |
| Surge forward current | $t_p = 100 \mu s$ | I_{FSM} | 1.5 | A |
| Power dissipation | | P_V | 170 | mW |
| Junction temperature | | T_j | 100 | $^{\circ}C$ |
| Operating temperature range | | T_{amb} | - 40 to + 85 | $^{\circ}C$ |
| Storage temperature range | | T_{stg} | - 40 to + 100 | $^{\circ}C$ |
| Soldering temperature | Acc. figure 11, J-STD-020 | T_{sd} | 260 | $^{\circ}C$ |
| Thermal resistance junction/ambient | J-STD-051, soldered on PCB | R_{thJA} | 250 | K/W |

Note

$T_{amb} = 25 \text{ }^{\circ}C$, unless otherwise specified

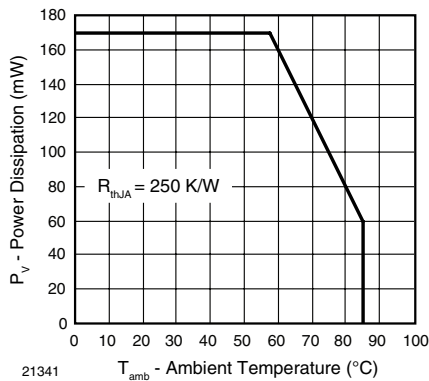


Fig. 1 - Power Dissipation Limit vs. Ambient Temperature

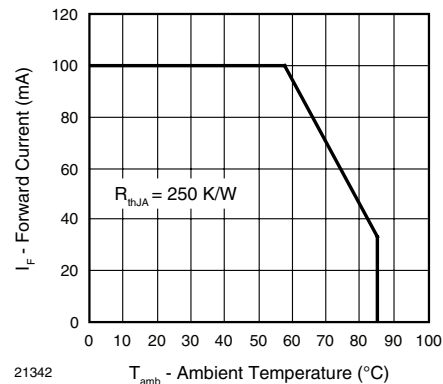


Fig. 2 - Forward Current Limit vs. Ambient Temperature

| BASIC CHARACTERISTICS | | | | | | |
|--|---|------------------|------|----------|------|---------|
| PARAMETER | TEST CONDITION | SYMBOL | MIN. | TYP. | MAX. | UNIT |
| Forward voltage | $I_F = 100 \text{ mA}$, $t_p = 20 \text{ ms}$ | V_F | | 1.3 | 1.7 | V |
| | $I_F = 1 \text{ A}$, $t_p = 100 \mu s$ | V_F | | 1.8 | | V |
| Temperature coefficient of V_F | $I_F = 100 \text{ mA}$ | TK_{V_F} | | - 1.3 | | mV/K |
| Reverse current | $V_R = 5 \text{ V}$ | I_R | | | 100 | μA |
| Junction capacitance | $V_R = 0 \text{ V}$, $f = 1 \text{ MHz}$, $E = 0$ | C_j | | 30 | | pF |
| Radiant intensity | $I_F = 100 \text{ mA}$, $t_p = 20 \text{ ms}$ | I_e | 1.6 | 4.5 | 8 | mW/sr |
| | $I_F = 1.5 \text{ A}$, $t_p = 100 \mu s$ | I_e | | 35 | | mW/sr |
| Radiant power | $I_F = 100 \text{ mA}$, $t_p = 20 \text{ ms}$ | ϕ_e | | 15 | | mW |
| Temperature coefficient of ϕ_e | $I_F = 100 \text{ mA}$ | TK_{ϕ_e} | | - 0.8 | | %/K |
| Angle of half intensity | | φ | | ± 60 | | deg |
| Peak wavelength | $I_F = 100 \text{ mA}$ | λ_p | | 950 | | nm |
| Spectral bandwidth | $I_F = 100 \text{ mA}$ | $\Delta\lambda$ | | 50 | | nm |
| Temperature coefficient of λ_p | $I_F = 100 \text{ mA}$ | TK_{λ_p} | | 0.2 | | nm/K |
| Rise time | $I_F = 20 \text{ mA}$ | t_r | | 800 | | ns |
| | $I_F = 1 \text{ A}$ | t_r | | 400 | | ns |
| Fall time | $I_F = 20 \text{ mA}$ | t_f | | 800 | | ns |
| | $I_F = 1 \text{ A}$ | t_f | | 400 | | ns |
| Virtual source diameter | EN 60825-1 | d | | 0.5 | | mm |

Note

$T_{amb} = 25 \text{ }^{\circ}C$, unless otherwise specified

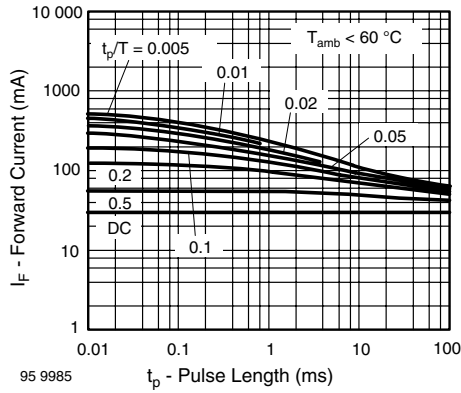
BASIC CHARACTERISTICS
 $T_{amb} = 25\text{ }^{\circ}\text{C}$, unless otherwise specified


Fig. 3 - Pulse Forward Current vs. Pulse Duration

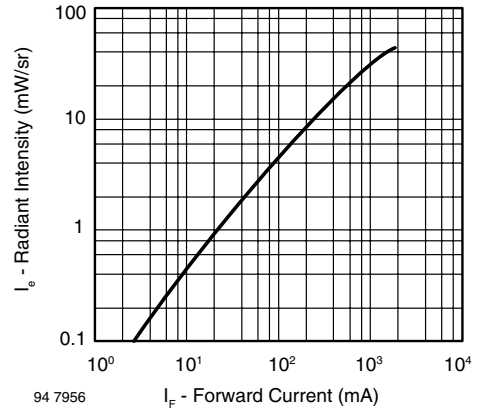


Fig. 6 - Radiant Intensity vs. Forward Current

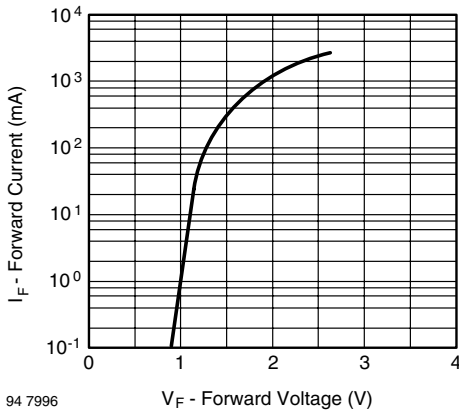


Fig. 4 - Forward Current vs. Forward Voltage

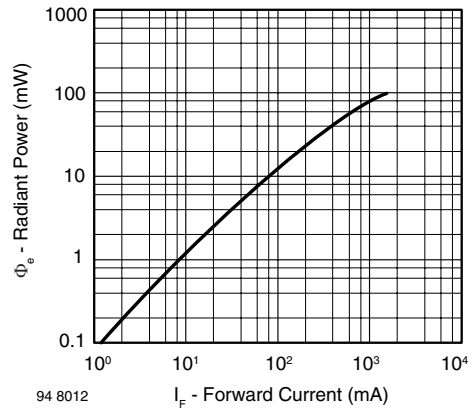


Fig. 7 - Radiant Power vs. Forward Current

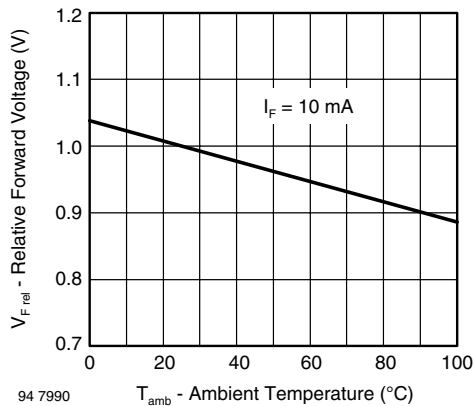


Fig. 5 - Relative Forward Voltage vs. Ambient Temperature

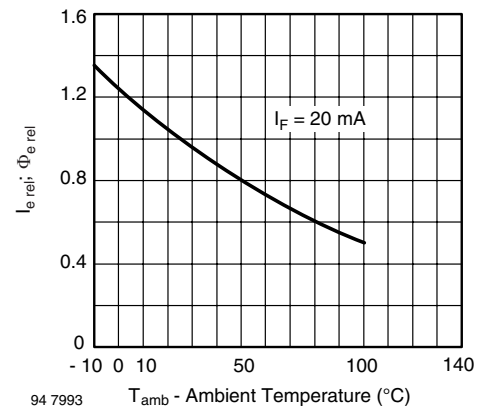


Fig. 8 - Relative Radiant Intensity/Power vs. Ambient Temperature

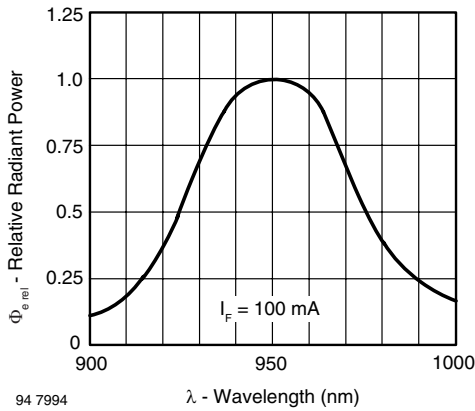


Fig. 9 - Relative Radiant Power vs. Wavelength

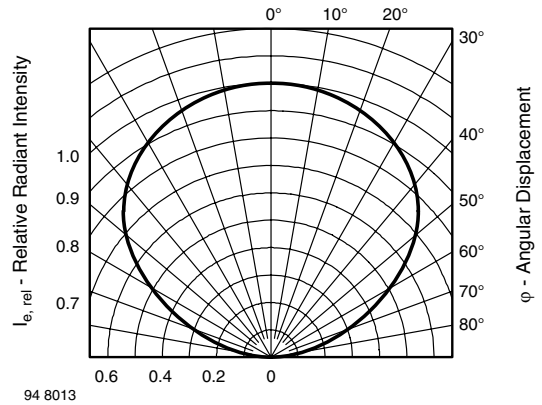
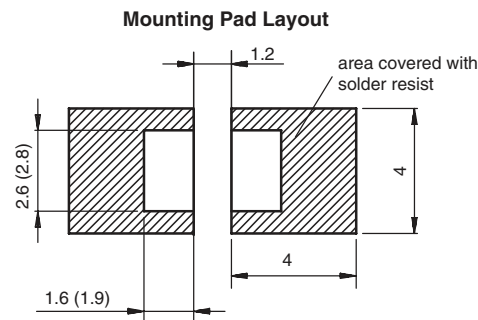
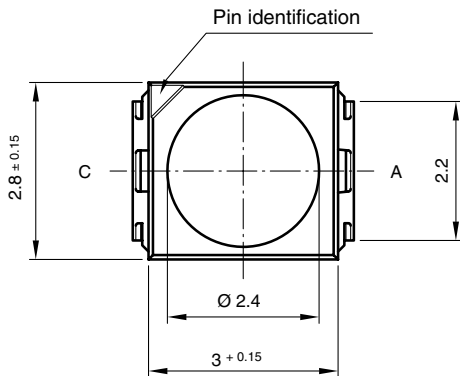
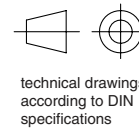
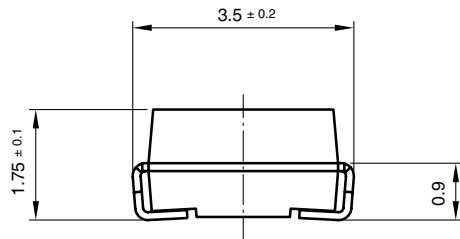


Fig. 10 - Relative Radiant Intensity vs. Angular Displacement

PACKAGE DIMENSIONS in millimeters



Drawing-No.: 6.541-5067.01-4
 Issue: 5; 04.11.08
 20541

Die Position (for reference only)

- X = +/- 0.2 mm central
- Y = +/- 0.2 mm central
- Z = 1.13 mm +/- 0.25 mm, from top of die bottom of component

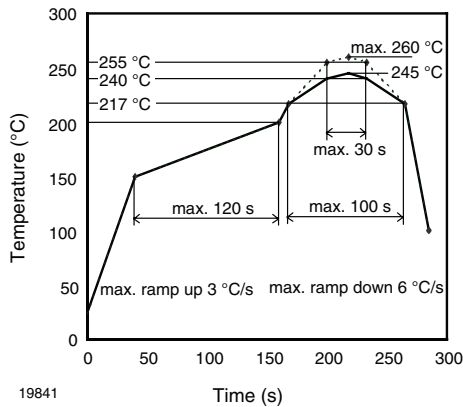
SOLDER PROFILE


Fig. 11 - Lead (Pb)-free Reflow Solder Profile acc. J-STD-020

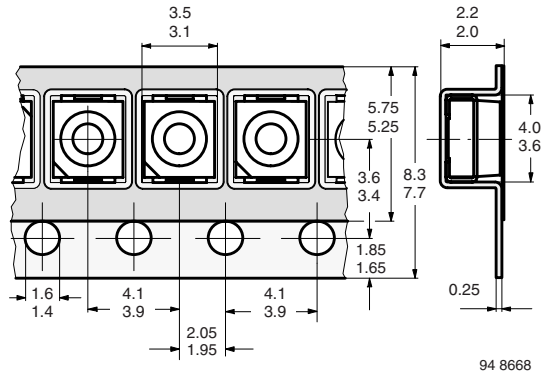


Fig. 13 - Tape Dimensions in mm for PLCC-2

DRYPACK

Devices are packed in moisture barrier bags (MBB) to prevent the products from moisture absorption during transportation and storage. Each bag contains a desiccant.

FLOOR LIFE

Floor life (time between soldering and removing from MBB) must not exceed the time indicated on MBB label:

Floor life: 168 h

Conditions: $T_{amb} < 30\text{ }^{\circ}\text{C}$, RH < 60 %

Moisture sensitivity level 3, acc. to J-STD-020.

DRYING

In case of moisture absorption devices should be baked before soldering. Conditions see J-STD-020 or label. Devices taped on reel dry using recommended conditions 192 h at 40 °C (+ 5 °C), RH < 5 %.

TAPE AND REEL

PLCC-2 components are packed in antistatic blister tape (DIN IEC (CO) 564) for automatic component insertion. Cavities of blister tape are covered with adhesive tape.

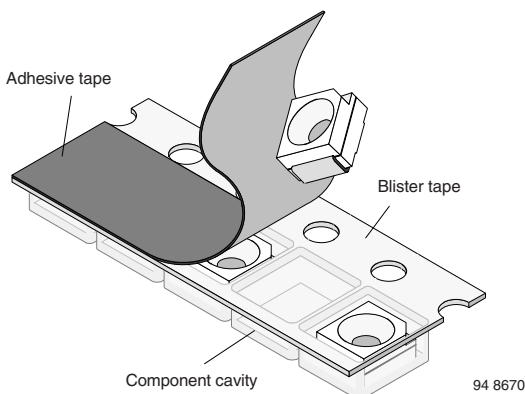


Fig. 12 - Blister Tape

MISSING DEVICES

A maximum of 0.5 % of the total number of components per reel may be missing, exclusively missing components at the beginning and at the end of the reel. A maximum of three consecutive components may be missing, provided this gap is followed by six consecutive components.

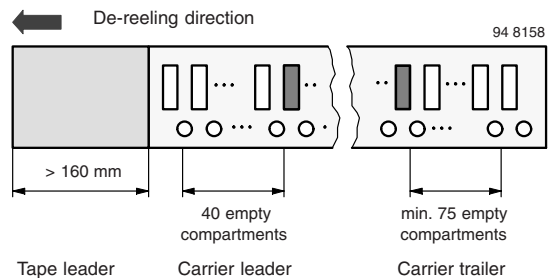


Fig. 14 - Beginning and End of Reel

The tape leader is at least 160 mm and is followed by a carrier tape leader with at least 40 empty compartments. The tape leader may include the carrier tape as long as the cover tape is not connected to the carrier tape. The least component is followed by a carrier tape trailer with a least 75 empty compartments and sealed with cover tape.

COVER TAPE REMOVAL FORCE

The removal force lies between 0.1 N and 1.0 N at a removal speed of 5 mm/s. In order to prevent components from popping out of the blisters, the cover tape must be pulled off at an angle of 180° with regard to the feed direction.

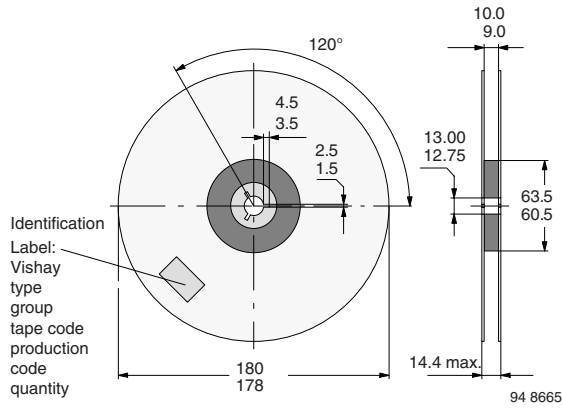


Fig. 15 - Dimensions of Reel-GS08

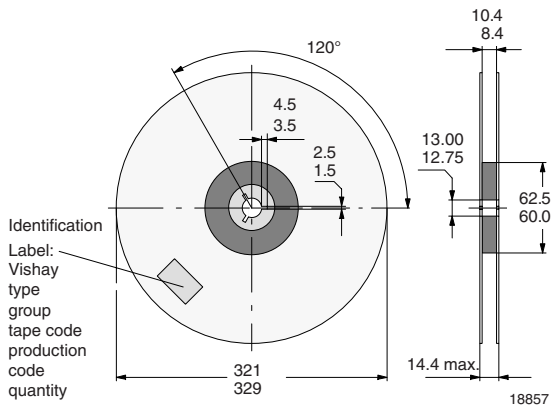


Fig. 16 - Dimensions of Reel-GS18



Disclaimer

ALL PRODUCT, PRODUCT SPECIFICATIONS AND DATA ARE SUBJECT TO CHANGE WITHOUT NOTICE TO IMPROVE RELIABILITY, FUNCTION OR DESIGN OR OTHERWISE.

Vishay Intertechnology, Inc., its affiliates, agents, and employees, and all persons acting on its or their behalf (collectively, "Vishay"), disclaim any and all liability for any errors, inaccuracies or incompleteness contained in any datasheet or in any other disclosure relating to any product.

Vishay makes no warranty, representation or guarantee regarding the suitability of the products for any particular purpose or the continuing production of any product. To the maximum extent permitted by applicable law, Vishay disclaims (i) any and all liability arising out of the application or use of any product, (ii) any and all liability, including without limitation special, consequential or incidental damages, and (iii) any and all implied warranties, including warranties of fitness for particular purpose, non-infringement and merchantability.

Statements regarding the suitability of products for certain types of applications are based on Vishay's knowledge of typical requirements that are often placed on Vishay products in generic applications. Such statements are not binding statements about the suitability of products for a particular application. It is the customer's responsibility to validate that a particular product with the properties described in the product specification is suitable for use in a particular application. Parameters provided in datasheets and/or specifications may vary in different applications and performance may vary over time. All operating parameters, including typical parameters, must be validated for each customer application by the customer's technical experts. Product specifications do not expand or otherwise modify Vishay's terms and conditions of purchase, including but not limited to the warranty expressed therein.

Except as expressly indicated in writing, Vishay products are not designed for use in medical, life-saving, or life-sustaining applications or for any other application in which the failure of the Vishay product could result in personal injury or death. Customers using or selling Vishay products not expressly indicated for use in such applications do so at their own risk and agree to fully indemnify and hold Vishay and its distributors harmless from and against any and all claims, liabilities, expenses and damages arising or resulting in connection with such use or sale, including attorneys fees, even if such claim alleges that Vishay or its distributor was negligent regarding the design or manufacture of the part. Please contact authorized Vishay personnel to obtain written terms and conditions regarding products designed for such applications.

No license, express or implied, by estoppel or otherwise, to any intellectual property rights is granted by this document or by any conduct of Vishay. Product names and markings noted herein may be trademarks of their respective owners.