

DESCRIPTION

The LX8940 is a 5V, low dropout, low quiescent current regulator rated for 1A of output current. It can regulate with as low as 0.4V headroom between the input and output voltages, thus minimizing power dissipation. In addition, it can be used in applications where worst

case supplies require a low input-output differential to maintain regulation. This feature makes it ideal for computer monitors that have to comply with energy-efficient / "Green PC" programs, where the input voltage drops to only a few tenths of a volt above the output when power supply enters sleep-mode operation.

IMPORTANT: For the most current data, consult MICROSEMI's website: <http://www.microsemi.com>

KEY FEATURES

- 2% Internally Trimmed Output
- Output Current In Excess Of 1A
- Input-Output Differential Less Than 0.4V At 1A
- Reverse Battery Protection
- 60V Load Dump Protection
- -50V Reverse Transient Protection
- Short Circuit Protection
- Internal Thermal Overload Protection
- Available In 3-Lead Plastic TO-220
- Drops In Most IM2940 Sockets

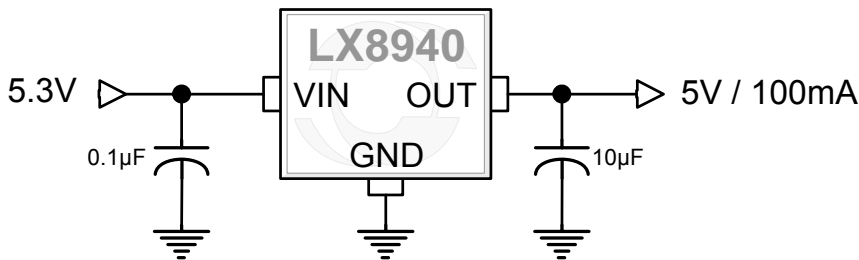
PRODUCT HIGHLIGHT

APPLICATIONS

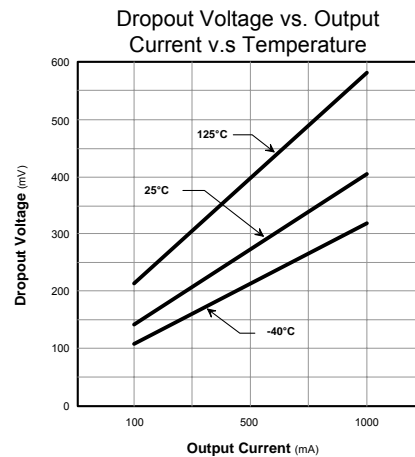
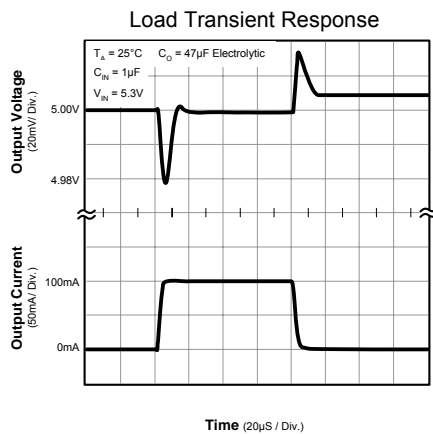
- Small Headroom Battery Applications
- High Efficiency Linear Regulators
- Post Regulators For Switching Power Supplies
- Green PC Monitor Applications

PACKAGE ORDER INFO

T_A (°C)	P	Plastic TO-220 3-Pin
		RoHS Compliant / Pb-free Transition DC: 0543
0 to 125		LX8940CP
-40 to 125		LX8940IP

Note: Available in Tape & Reel. Append the letters "TR" to the part number. (i.e. LX8940IP-TR)

ABSOLUTE MAXIMUM RATINGS

Input Voltage (VIN)..... -15V to 26V
 Maximum Operating Junction Temperature 150°C
 Storage Temperature Range.....-65°C to 150°C
 Peak Package Solder Reflow Temp. (40 seconds max. exposure) 260°C (+0,-5)

Note: Exceeding these ratings could cause damage to the device. All voltages are with respect to Ground. Currents are positive into, negative out of specified terminal. Pin numbers refer to DIL packages only

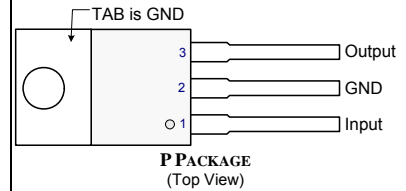
PACKAGE PIN OUT

RoHS / Pb-free 100% matte Tin Lead Finish

THERMAL DATA
P Plastic TO-220 3-Pin

THERMAL RESISTANCE-JUNCTION TO TAB, θ_{JT}	3.0°C/W
THERMAL RESISTANCE-JUNCTION TO AMBIENT, θ_{JA}	60°C/W

Junction Temperature Calculation: $T_J = T_A + (P_D \times \theta_{JA})$.

The θ_{JA} numbers are guidelines for the thermal performance of the device/pc-board system. All of the above assume no ambient airflow.

RECOMMENDED OPERATING CONDITIONS

Parameter	Symbol	LX8940			Units
		Min	Typ	Max	
Input Voltage	VIN	Note 2		26	V
Load Current (with adequate heatsinking)		5		1000	mA
Maximum Line Transient (Load Dump), $V_O \leq 5.5V$				60	V
Input Capacitor (VIN to GND)		0.1			μF
Output Capacitor with ESR of 10Ω max., (V_{OUT} to GND & V_{SB} to GND)		10			μF

Note 2: $V_{IN(MIN)} = 1.2\Delta V_{(MAX)}$ See Dropout Voltage Maximum Limit.

ELECTRICAL CHARACTERISTICS

Unless otherwise specified, the following specifications apply over the operating ambient temperature -40°C to $+125^{\circ}\text{C}$ for the LX8940IP and 0°C to $+125^{\circ}\text{C}$ for LX8940CP; $V_{\text{IN}} = 10\text{V}$, $I_{\text{O}} = 1\text{A}$, $C_{\text{OUT}} = 22\mu\text{F}$, and for DC characteristics only. Low duty cycle pulse testing techniques are used which maintains junction and case temperatures equal to the ambient temperature.)

Parameter	Symbol	Test Conditions	LX8940			Units
			Min	Typ	Max	
SECTION HEADER						
Output Voltage	V_{O}	$I_{\text{O}} = 0\text{A}$, $T_{\text{A}} = 25^{\circ}\text{C}$	4.85	5	5.15	V
Line Regulation	ΔV_{OI}	$7\text{V} \leq V_{\text{IN}} \leq 26$, $I_{\text{O}} = 5\text{mA}$		1	50	mV
Load Regulation	ΔV_{OL}	$50\text{mA} \leq I_{\text{O}} \leq 1\text{A}$		10	50	mV
Output Impedance (Note 3)	r_{O}	100mA_{DC} and 20mA_{RMS} , $f_{\text{O}} = 120\text{Hz}$		200		$\text{m}\Omega$
Quiescent Current	I_{Q}	$I_{\text{O}} \leq 5\text{mA}$, $7 \leq V_{\text{IN}} \leq 26\text{V}$		3	15	mA
		$I_{\text{O}} = 500\text{mA}$		30	50	mA
		$I_{\text{O}} = 1000\text{mA}$		115	180	mA
Output Noise Voltage (Note 3)	V_{ORMS}	$10\text{Hz} - 100\text{kHz}$, $I_{\text{O}} = 5\text{mA}$		150		μV_{RMS}
Long Term Stability (Note 3)				20		$\text{mV} / 1000\text{hr}$
Ripple Rejection (Note 3)	R_{R}	$f_{\text{O}} = 120\text{Hz}$, 1V_{RMS} , $I_{\text{O}} = 100\text{mA}$		66		dB
Dropout Voltage	ΔV	$I_{\text{O}} = 100\text{mA}$		150	300	mV
		$I_{\text{O}} = 500\text{mA}$		275	500	mV
		$I_{\text{O}} = 1\text{A}$		400	800	mV
Current Limit	I_{CL}	$V_{\text{IN}} = 26\text{V}$	1	1.2		A
Maximum Operational Input Voltage	$V_{\text{IN(MAX)}}$		26	31		V
Maximum Line Transient	$V_{\text{IN(TR)}}$	$R_{\text{O}} = 100\Omega$, $T < 100\text{mS}$		60		V

Note 3: These parameters, although guaranteed, are not tested in production.

SIMPLIFIED BLOCK DIAGRAM

Figure 1 – Simplified Block Diagram

APPLICATION NOTE

The advantages of using a low-dropout regulator such as the LX8940 is the need for less “headroom” for full regulation, and the inherent reverse polarity protection provided by the PNP output device. A typical NPN regulator design requires an input to output differential of approximately two volts minimum. This is due to the $2V_{be} + V_{cesat}$ of the NPN Darlington used in the output, coupled with the voltage drop across the current limit resistor. In contrast, the “PNP Regulator” uses a single series pass transistor with its single V_{cesat} , thus the lower input to output voltage differential or dropout voltage. In some applications the regulator output voltage is used not only as a power supply but also as a voltage reference for control systems. In such cases not just the temperature stability of the output is important but also the initial accuracy. LX8940 fills this need as the internal bandgap reference is trimmed allowing a typical output voltage tolerance of $\pm 1\%$.

EXTERNAL CAPACITORS

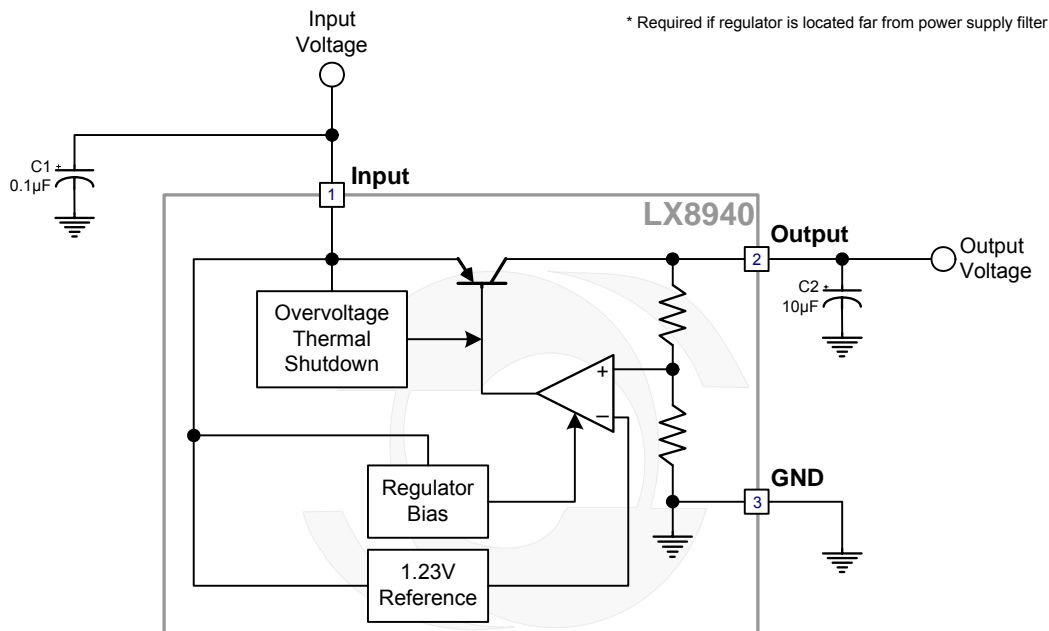
To stabilize the outputs and prevent oscillation (perhaps by many volts) external capacitors are required. The minimum recommended value for the output capacitors is $10\mu\text{F}$, although the actual size and type will likely vary according to the particular application, e.g., operating temperature range and load. Another consideration is the effective series resistance (ESR) of the

capacitor. Capacitor ESR will vary by manufacturer. Consequently, some evaluation may be required to determine the minimum value of the output capacitors. Generally worst case occurs at the maximum load and minimum ambient temperature. The size of the output capacitor can be increased to any value above the minimum. One possible advantage of this would be to maintain the output voltage during brief periods of negative input transients. The output capacitors chosen should be rated for the full range of ambient temperature over which the circuit will be exposed and expected to operate. For example, many aluminum type electrolytic capacitors change values at cold temperatures. The effective capacitance is reduced and regulator stability is affected. Tantalum capacitors are a good choice for these types of environments.

OUTPUT PROTECTION

The output features fault protection against over voltage as well as a thermal shutdown feature. If the input voltage rises above 33V (load dump), the output shuts down automatically. The internal circuitry is thus protected and the IC is able to survive higher voltage transients than might otherwise be expected. The thermal shutdown output effectively guards against overheating of the die and protects the device from being damaged.

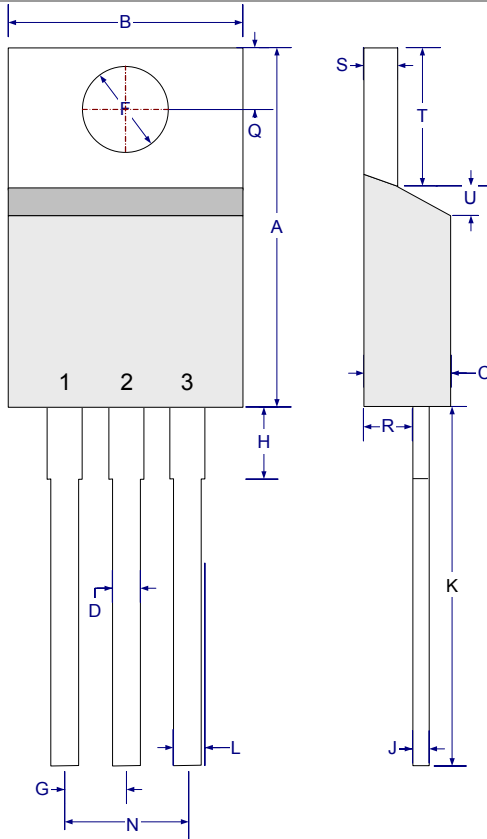
PACKAGE DIMENSIONS
P 3-Pin Plastic TO-220

Dim	MILLIMETERS		INCHES	
	MIN	MAX	MIN	MAX
A	14.22	15.88	0.560	0.625
B	9.65	10.67	0.380	0.420
C	3.56	4.83	0.140	0.190
D	0.51	1.14	0.020	0.045
F	3.53	4.09	0.139	0.161
G	2.54 BSC		0.100 BSC	
H		6.35		0.250
J	0.30	1.14	0.012	0.045
K	12.70	14.73	0.500	0.580
L	1.14	1.27	0.045	0.050
N	5.08 TYP		0.200 TYP	
Q	2.54	3.05	0.100	0.120
R	2.03	2.92	0.080	0.115
S	1.14	1.40	0.045	0.055
T	5.84	6.86	0.230	0.270
U	0.508	1.14	0.020	0.045

Note:

- Dimensions do not include mold flash or protrusions; these shall not exceed 0.155mm(.006") on any side. Lead dimension shall not include solder coverage.



Microsemi[®]

LX8940

5V Low Dropout Regulator

PRODUCTION DATA SHEET

NOTES

PRODUCTION DATA – Information contained in this document is proprietary to Microsemi and is current as of publication date. This document may not be modified in any way without the express written consent of Microsemi. Product processing does not necessarily include testing of all parameters. Microsemi reserves the right to change the configuration and performance of the product and to discontinue product at any time.