



SPX2975

400mA Low Dropout Voltage Regulator

FEATURES

- 5V Fixed Output
- High Accuracy
- Very Low Current Consumption: 60 μ A
- Power-on and Under Voltage Reset
- Reset Low Down to $V_{OUT} = 1V$
- Extremely Low Dropout Voltage
- Short Circuit Protection
- Programmable Safety Timer
- 4kV ESD Protection

APPLICATIONS

- Automotive Electronics
- Wireless Station
- Industrial Systems

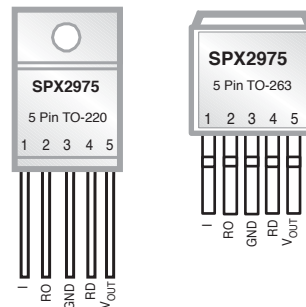

Now Available in Lead Free Packaging

DESCRIPTION

Sipex's SPX2975 is a low dropout linear regulator with integrated PNP pass transistor. The part is available in a 5 pin TO-220 package or surface mount TO-263. The part used to convert an automotive battery voltage, with allowable input up to 45V, down to 5V with at least 400mA output current delivered. Internal power consumption is kept to 60 μ A ideal for applications where micro-power operation is important. At over-temperature the SPX2975 is turned off by the integrated temperature protection circuit. A reset signal is generated for a typical output voltage of 4.65V with a time delay that can be programmed by an external delay capacitor.

TYPICAL APPLICATION CIRCUIT

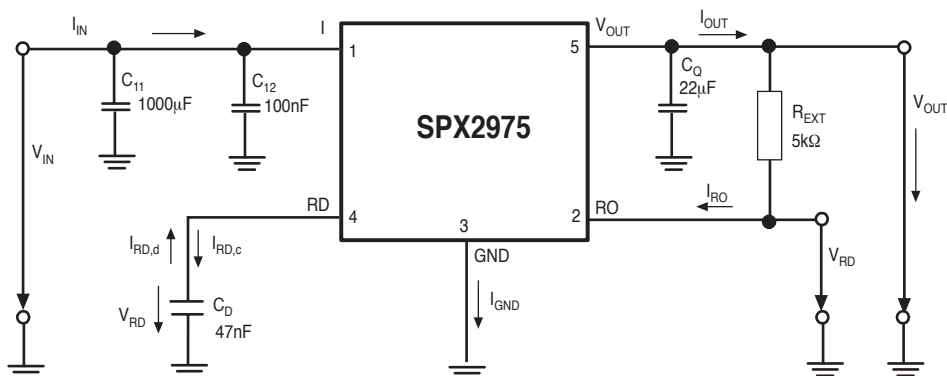

Input Voltage	-42V to 45V
Output Voltage	-1.0 to 16V
Output Current	Internally limited
Reset Output Voltage	-0.3 to 25V
Reset Output Current	-5mA to +5mA
Reset Delay Voltage	-0.3V to 7.0V
Reset Delay Current	-2mA to 2mA
Storage Temperature	-50°C to +150°C
Junction Temperature (Note 1)	-40°C to +150°C

T _{JA} (TO-252)	78°C/W
T _{JA} (TO-220)	65°C/W
T _{JA} (TO-263)	53°C/W
T _{JC} (TO-220, TO 263, and TO-252)	4°C/W

These are stress ratings only and functional operation of the device at these ratings or any other above those indicated in the operation sections of the specifications below is not implied. Exposure to absolute maximum rating conditions for extended periods of time may affect reliability.

ABSOLUTE MAXIMUM RATINGS

ELECTRICAL CHARACTERISTICS

V_{IN} = 13.5V; -40°C < T_j < 150°C. Unless otherwise specified.

PARAMETER	SYM	MIN.	TYP.	MAX.	UNITS	CONDITIONS
Input Voltage	V _I	5.5		42	V	
Junction Temperature	T _J	-40		150	°C	
Output Voltage	V _O	4.9	5.0	5.1	V	5mA < I _O < 400mA, 6V < V _I < 28V
		4.9	5.0	5.1		5mA < I _O < 200mA, 6V < V _I < 40V
		4.9		5.25		100μA ≤ I _O ≤ 5mA, 6V < V _I < 28V
Output Current limitation	I _O	450	700		mA	
Current Consumption	I _q		60	100	μA	I _{OUT} = 100 μA, T _j = 25°C
			60	120		I _{OUT} = 100 μA, T _j = 85°C
			70	180		I _{OUT} = 1mA, T _j = 25°C
			70	200		I _{OUT} = 1mA, T _j = 85°C
			7	10	mA	I _{OUT} = 250mA
			17	22		I _{OUT} = 400mA
Dropout Voltage (note 1)	V _{dr}		350	500	mV	I _{OUT} = 300mA, V _{DO} = V _{OUT} - V _{IN}
Load Regulation	ΔV _O	-30	5	30	mV	I _{OUT} = 5mA to 400mA
		-200		200		I _{OUT} = 100μA ≤ I _O ≤ 5mA
Line Regulation	ΔV _O	-15	2	15	mV	V _{IN} = 8V to 32V, I _{OUT} = 5mA
PSRR	PSRR		60		dB	f _r = 100Hz; V _r = 0.5 Vpp
Temperature Output Voltage Drift	dV _O /dT		0.2		mV/K	
Reset Switching Threshold	V _{RT}	4.51	4.65	4.8	V	V _{TH}
Reset Output Low Voltage	V _{RQL}		0.2	0.4	V	R _{ext} ≥ 5kΩ ; V _{OUT} > 1 V
Reset Output Leakage Current	I _{ROH}		0	10	μA	V _{ROH} = 5V
Reset Charging Current	I _D	3.0	5.5	9.0	μA	V _{RD} = 1V
Upper Timing Threshold	V _{DU}	1.5	1.8	2.2	V	V _{thH}
Lower Timing Threshold	V _{DL}	0.2	0.4	0.7	V	V _{thL}
Reset Delay Time	t _d	10	16	22	ms	C _O = 47nF, Td
Reset Reaction Time	t _{RR}		0.5	2.0	μs	C _O = 47nF, Trv

Note 1: Measured when the output voltage (Vout) has dropped 100mV from the nominal value obtained at Vin=13.5V

FUNCTIONAL DIAGRAM

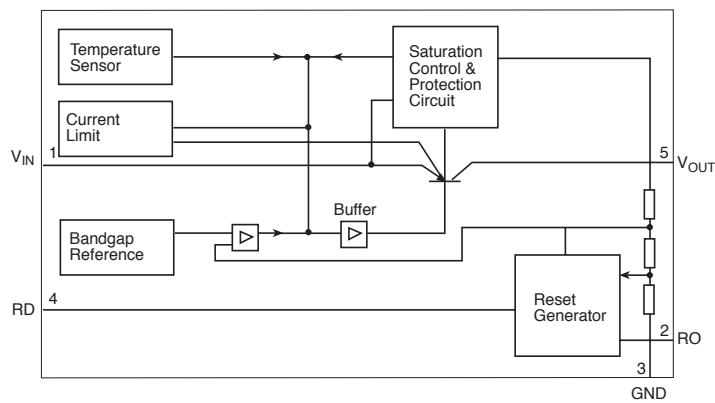

PIN DESCRIPTION

PIN NUMBER	PIN NAME	DESCRIPTION
1	V_{IN}	LDO Input. Bypass V_{IN} to GND with a Ceramic capacitor.
2	RO	Reset Output. RO remains low while V_{OUT} is below the reset switching threshold. RO is in open conector output.
3	GND	Ground. This pin also functions as a heatsink. Solder to large pads or the circuit-board ground plane to maximize thermal dissipation.
4	RD	Reset Delay. RD connects capacitor to GND for setting delay time.
5	V_{OUT}	LDO Output. Bypass V_{OUT} to GND with a minimum 22 μ F capacitor with ESR less than 5 Ω at 10kHz.

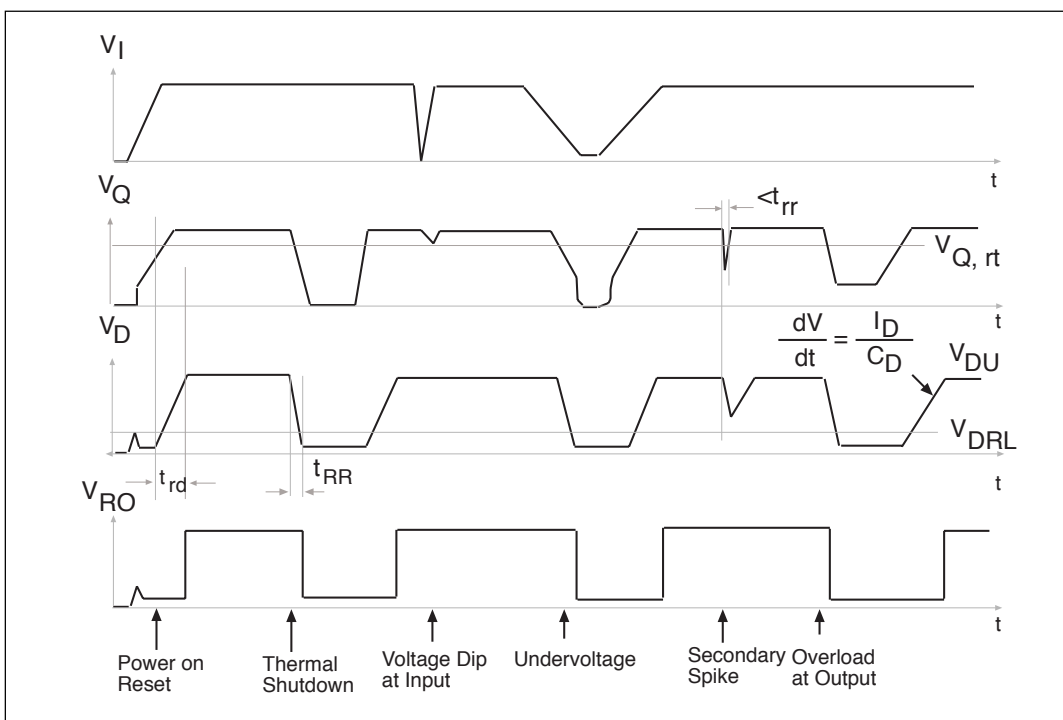

Reset Timing

TPYICAL PERFORMANCE CHARACTERISTICS

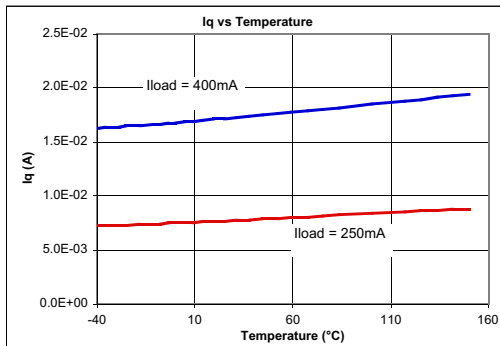
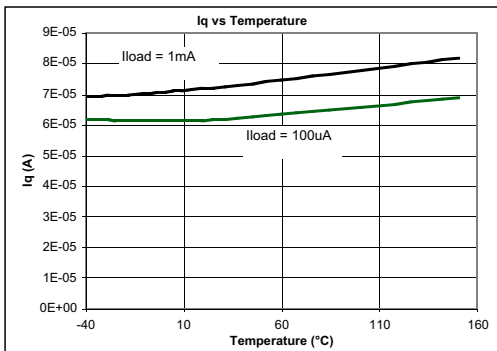
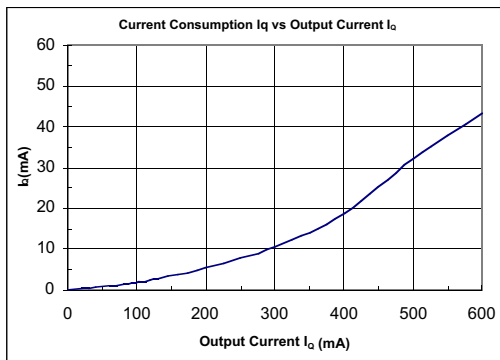
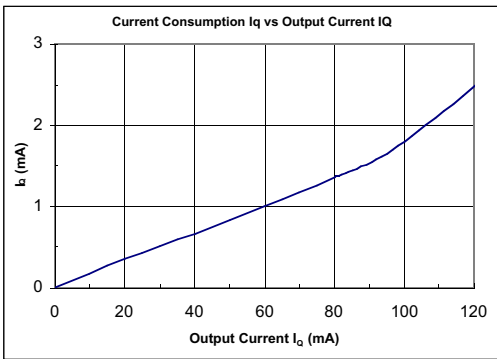
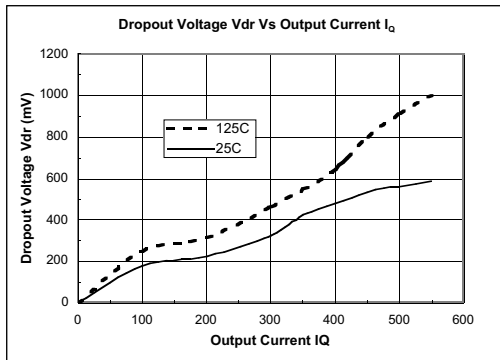
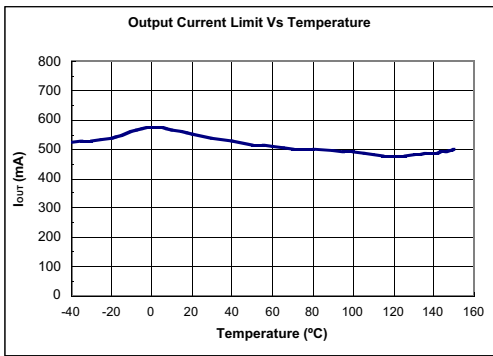

TPYICAL PERFORMANCE CHARACTERISTICS

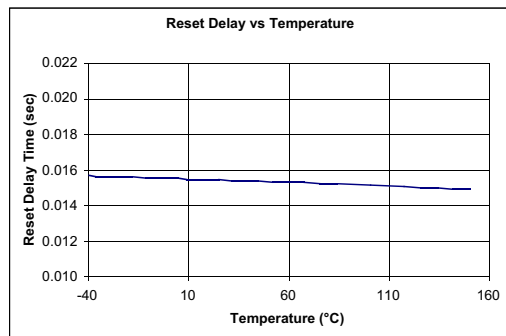
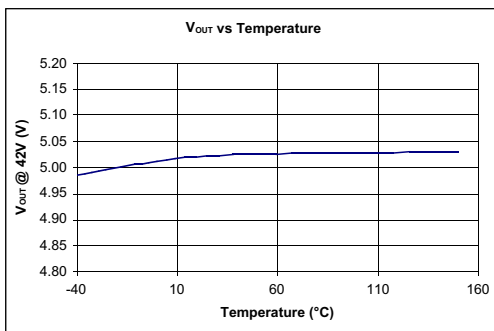
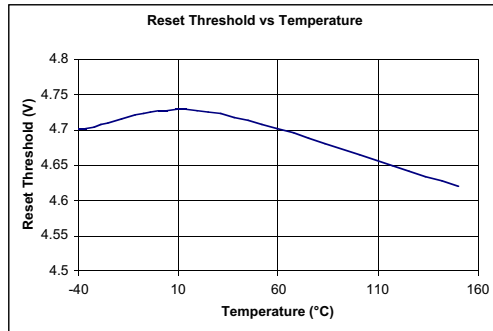
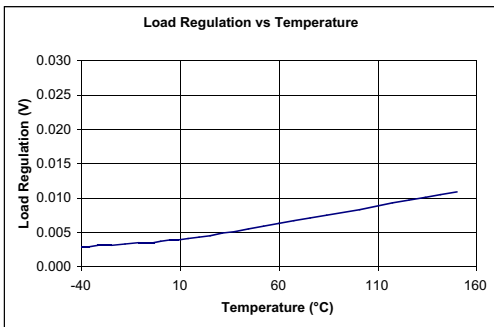

TYPICAL PERFORMANCE CHARACTERISTICS

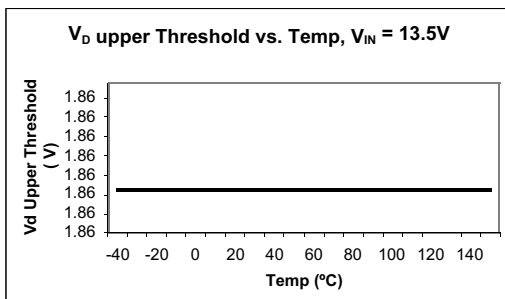
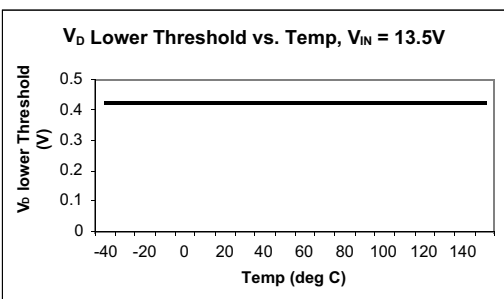
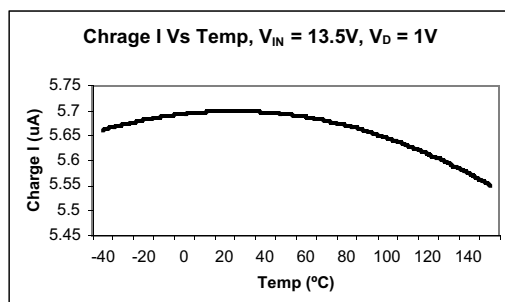
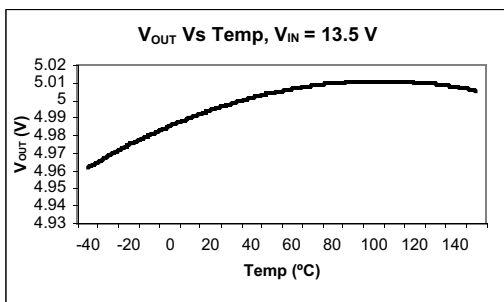
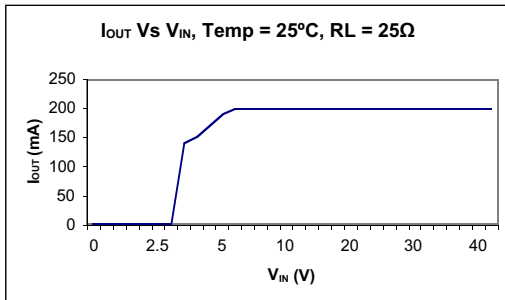
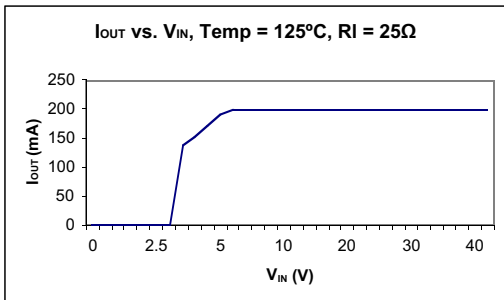
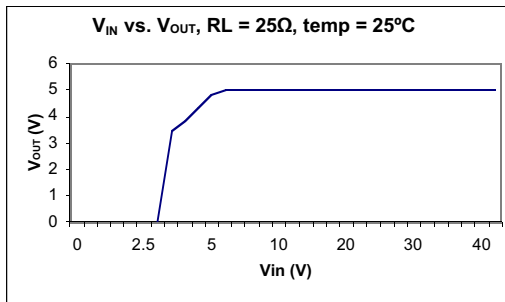
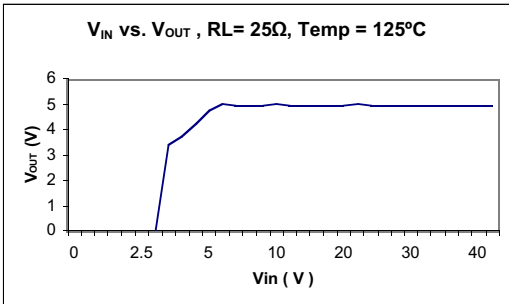

TPYICAL PERFORMANCE CHARACTERISTICS

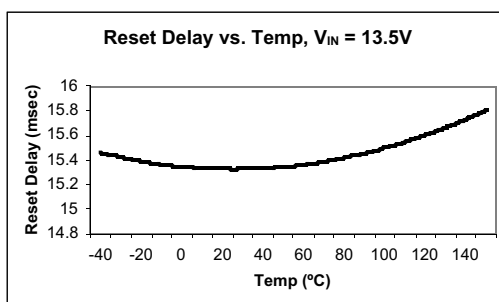
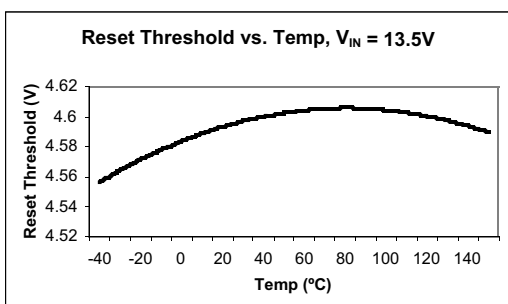
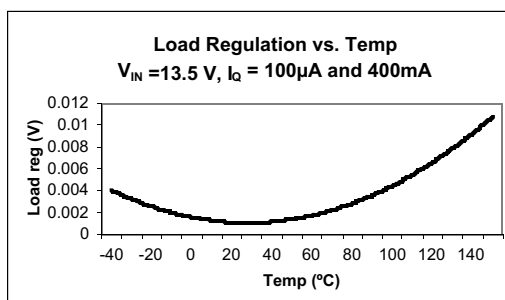
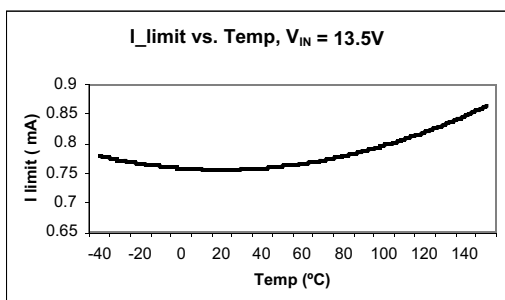

PACKAGE: 5 PIN TO-220

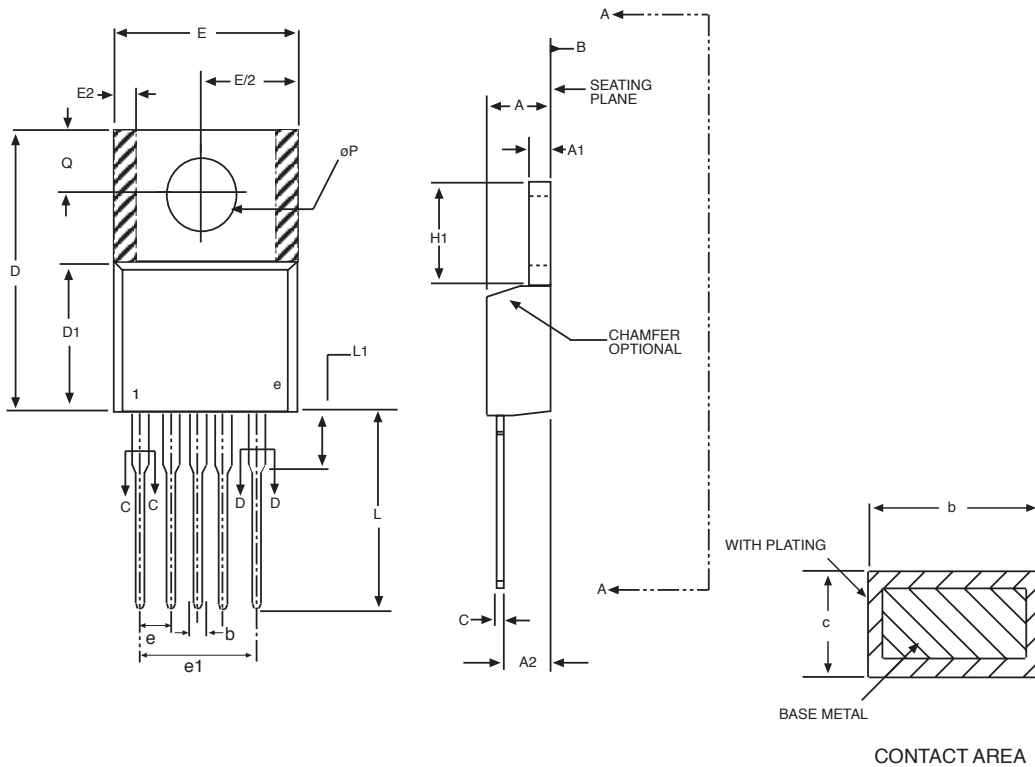

5 Pin TO-220 JEDEC TO-220 (AC) Variation			
SYMBOL	MIN	NOM	MAX
A	0.16	-	0.19
A1	0.02	-	0.055
A2	0.08	-	0.115
b	0.015	0.027	0.04
b2	0.045	-	0.07
c	0.014	-	0.024
D	0.56	-	0.65
D1	0.33	-	0.355
D2	0.48	-	0.507
E	0.38	-	0.42
E1	0.27	-	0.35
E2	-	-	0.03
e	.100 BSC		
e1	.100 BSC		
H1	0.23	-	0.27
L1	-	-	0.25
L2	-	-	-
ΔP	0.139	-	0.161
Q	0.1	-	0.135

Note: Dimensions in (mm)

5 Pin TO-220 JEDEC TO-220 (AC) Variation			
SYMBOL	MIN	NOM	MAX
A	0.006	-	0.007
A1	0.001	-	0.002
A2	0.003	-	0.005
b	0.001	0.001	0.002
b2	0.002	-	0.003
c	0.001	-	0.001
D	0.022	-	0.026
D1	0.013	-	0.014
D2	0.019	-	0.020
E	0.015	-	0.017
E1	0.011	-	0.014
E2	-	-	0.001
e	.004 BSC		
e1	.004 BSC		
H1	0.009	-	0.011
L1	-	-	0.010
L2	-	-	-
ΔP	0.005	-	0.006
Q	0.004	-	0.005

Note: Dimensions in (inch)

PACKAGE: 5 PIN TO-263

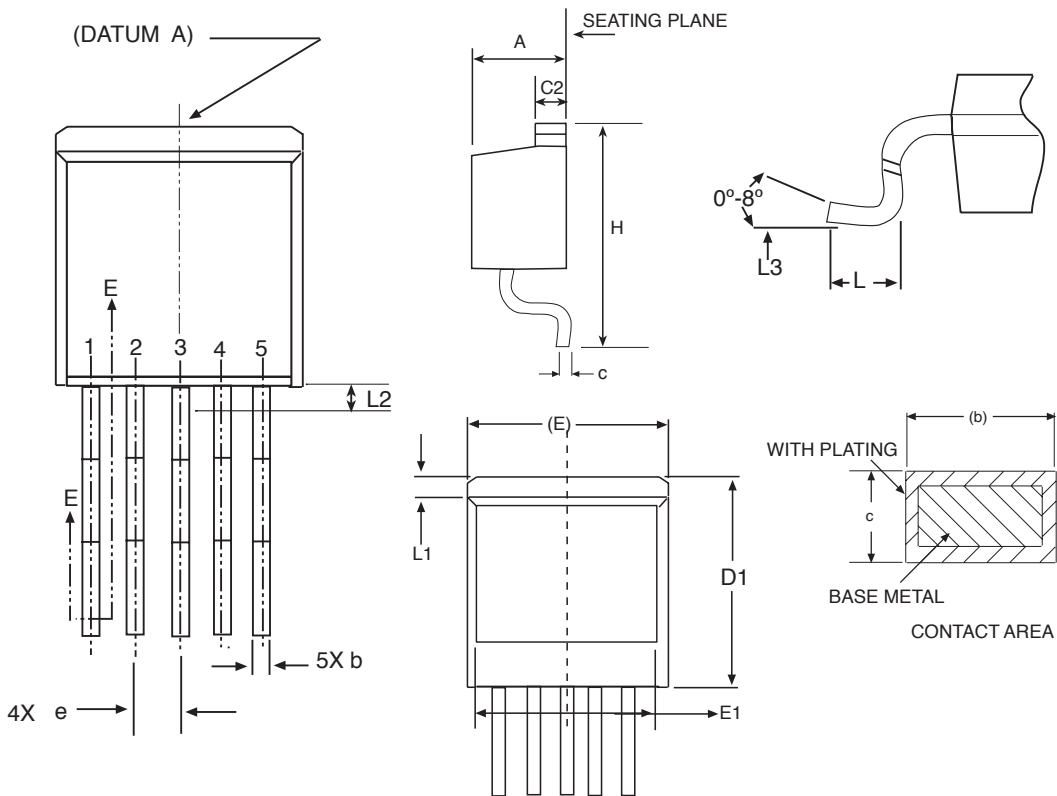

5 Pin TO-263 JEDEC TO-263 (BB) Variation			
SYMBOL	MIN	NOM	MAX
A	0.16	-	0.19
A1	0	-	0.01
b	0.02	-	0.039
c	0.015	-	0.029
c2	0.45	-	0.23
D1	0.27	-	-
E	0.38	-	0.42
E1	0.245	-	-
e	.067 BSC		
H	0.575	-	0.625
L	0.07	-	0.11
L1	-	-	0.066
L2	-	-	0.07
L3	.010 BSC		

Note: Dimensions in (mm)

5 Pin TO-263 JEDEC TO-263 (BB) Variation			
SYMBOL	MIN	NOM	MAX
A	0.006	-	0.007
A1	0.000	-	0.000
b	0.001	-	0.002
c	0.001	-	0.001
c2	0.018	-	0.009
D1	0.011	-	-
E	0.015	-	0.017
E1	0.010	-	-
e	.026 BSC		
H	0.023	-	0.025
L	0.003	-	0.004
L1	-	-	0.003
L2	-	-	0.003
L3	.004 BSC		

Note: Dimensions in (inch)

PACKAGE: 5 PIN TO-252

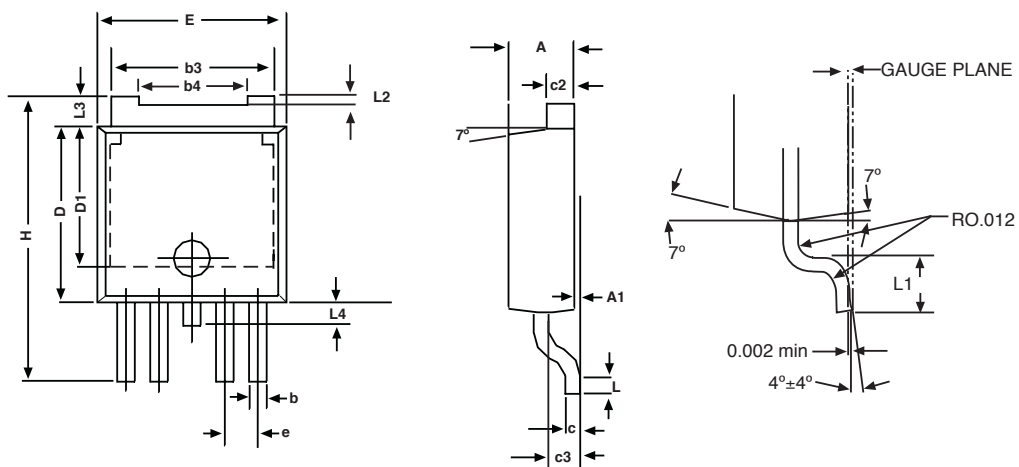

Symbol	MIN	NOM	MAX
A	0.086	0.090	0.094
b	0.020 TYP		
b3	0.205	0.210	0.215
b4	-	0.110	-
c	0.020	0.021	0.022
c2	0.018	0.020	0.022
c3	0.037	0.040	0.043
D	0.235	0.240	0.245
D1	0.184	0.189	0.194
E	0.253	0.258	0.263
e	0.045 TYP		
H	0.390 TYP		
L1	0.051	0.053	0.055
L2	-	0.013	-
L3	0.037	0.042	0.047
L4	0.028	0.032	0.036

Note: dimensions in (INCHES)

Symbol	MIN	NOM	MAX
A	2.18	2.29	2.39
b	0.51 TYP		
b3	5.21	5.33	5.46
b4	-	2.79	-
c	0.51	0.53	0.56
c2	0.46	0.51	0.56
c3	0.94	1.02	1.09
D	5.97	6.10	6.22
D1	4.67	4.80	4.93
E	6.43	6.55	6.68
e	1.14 TYP		
H	9.91 TYP		
L1	1.30	1.35	1.40
L2	-	0.33	-
L3	0.94	1.07	1.19
L4	0.71	0.81	0.91

Note: Dimensions in (mm)

ORDERING INFORMATION

Part number	Accuracy	Output Voltage	Package Type
SPX2975R5-5.02%	5.0V	5 Lead TO-252
SPX2975R5-5.0/TR2%	5.0V	5 Lead TO-252
SPX2975T5-5.02%	5.0V	5 Lead TO-263
SPX2975T5-5.0/TR2%	5.0V	5 Lead TO-263
SPX2975U5-5.02%	5.0V	5 Lead TO-220

Available in lead free packaging. To order add "-L" suffix to part number.

Example: SPX2975T5-5.0/TR = standard; SPX2975T5-L-5.0/TR = lead free

/TR = Tape and Reel

Pack quantity is 500 for TO-263 and 2,000 for TO-252.

→ [CLICK HERE TO ORDER SAMPLES](#) ←



ANALOG EXCELLENCE

Sipex Corporation

**Headquarters and
Sales Office**

233 South Hillview Drive
Milpitas, CA 95035
TEL: (408) 934-7500
FAX: (408) 935-7600

Sipex Corporation reserves the right to make changes to any products described herein. Sipex does not assume any liability arising out of the application or use of any product or circuit described herein; neither does it convey any license under its patent rights nor the rights of others.