

Control circuit for a Self-Oscillating Power Supply (SOPS)

TDA8385

FEATURES

- Bandgap reference generator
- Slow-start circuitry
- Low-loss peak current sensing
- Over-voltage protection
- Hysteresis controlled stand-by function
- Error amplifier with gain setting
- Programmable transfer character generator
- Protection against open- and short-circuited feedback loop
- Over-load current fold back characteristic
- LED driver
- Demagnetization protection
- Programmable determination of switch-on moment of switching transistor for low-switching losses
- Feed-forward input
- Regulation-indicator output
- Programmable minimum on-time of switching transistor
- Accurate peak-current setting.

GENERAL DESCRIPTION

The TDA8385 is intended to be used in combination with the opto-coupler (CNR50) as a control unit for a self-oscillating power supply.

ORDERING INFORMATION

EXTENDED TYPE NUMBER	PACKAGE			
	PINS	PIN POSITION	MATERIAL	CODE
TDA8385	16	DIL	plastic	SOT38WBE

Control circuit for a Self-Oscillating Power Supply (SOPS)

TDA8385

BLOCK DIAGRAMS

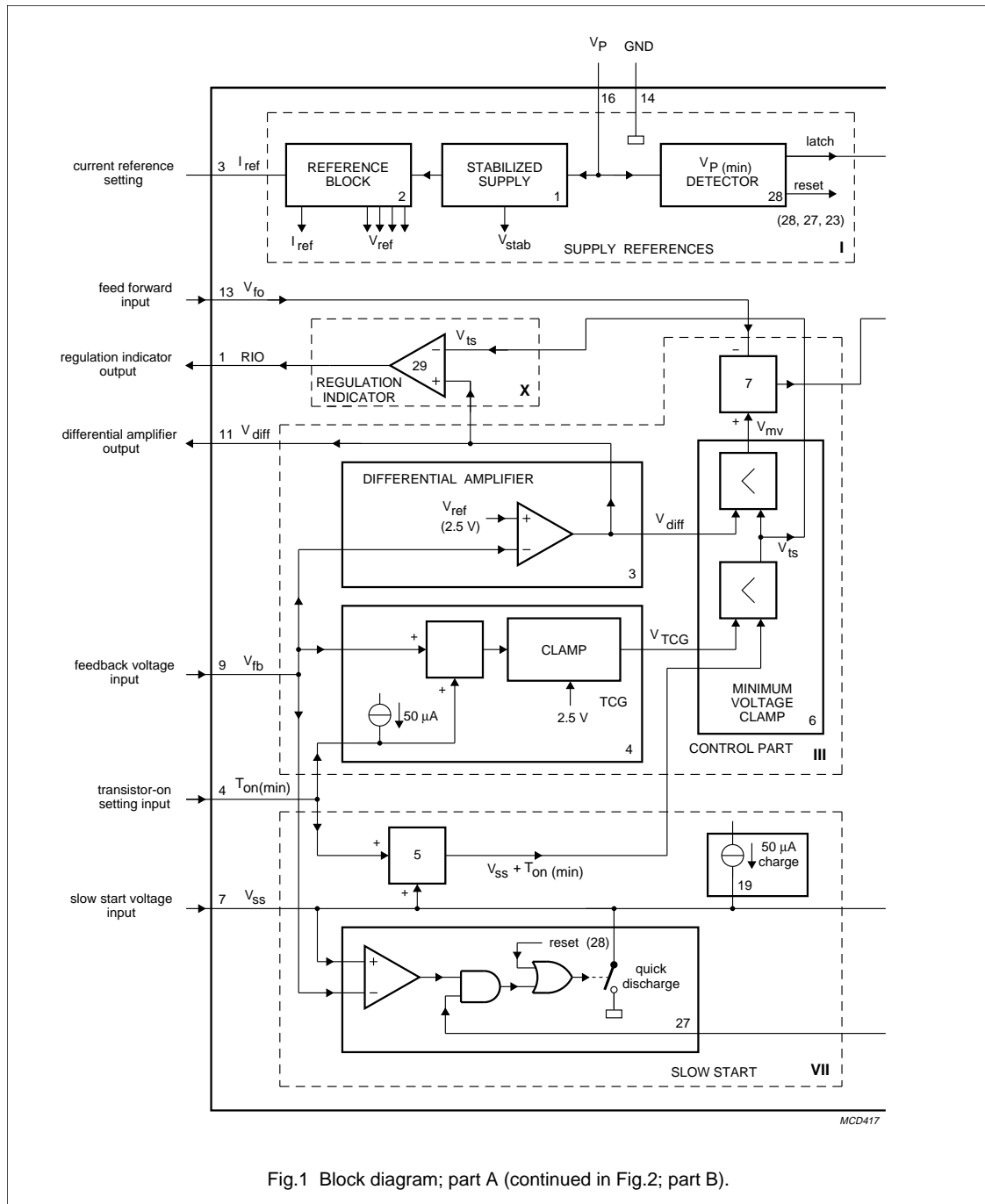

Fig.1 Block diagram; part A (continued in Fig.2; part B).

Control circuit for a Self-Oscillating Power Supply (SOPS)

TDA8385

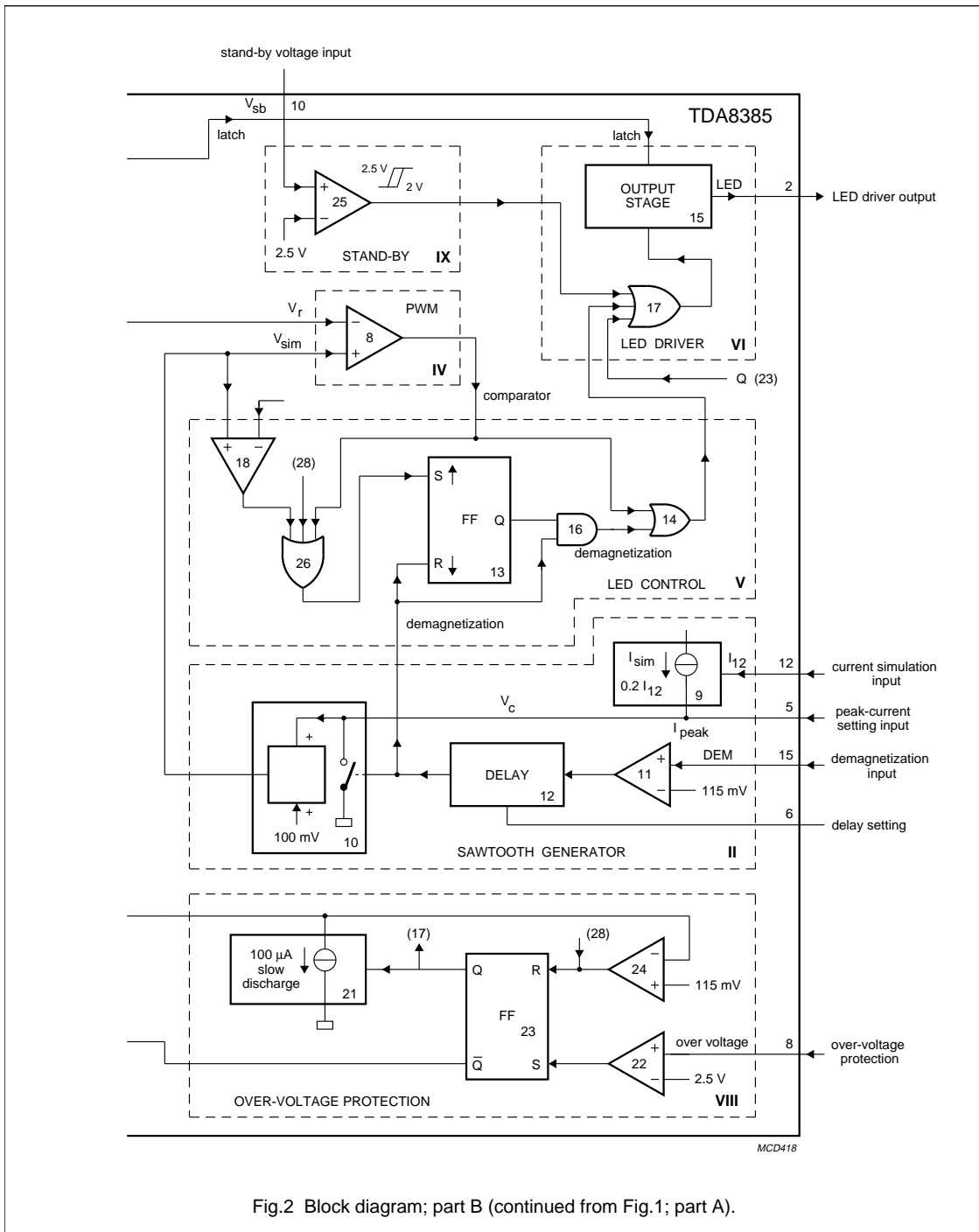

Fig.2 Block diagram; part B (continued from Fig.1; part A).

Control circuit for a Self-Oscillating Power Supply (SOPS)

TDA8385

PINNING

SYMBOL	PIN	DESCRIPTION
RIO	1	regulation indicator output
LED	2	LED driver output
I_{ref}	3	current reference setting
$T_{on(min)}$	4	transistor-on setting input
I_{peak}	5	peak current setting input
DELAY	6	delay setting
V_{ss}	7	slow start voltage input
OVP	8	over-voltage protection
V_{fb}	9	feedback voltage input
V_{sb}	10	stand-by voltage input
V_{diff}	11	differential amplifier output
I_{sim}	12	current simulation input
V_{fo}	13	feed forward input
GND	14	ground (0 V)
DEM	15	demagnetization input
V_P	16	positive supply voltage

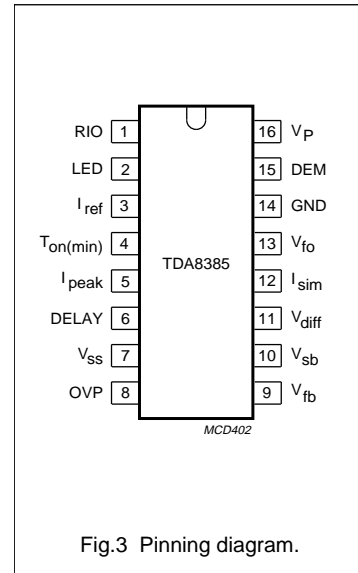

Fig.3 Pinning diagram.

FUNCTIONAL DESCRIPTION

The TDA8385 can be divided into 10 functional blocks as shown in Fig.1 and Fig.2.

Block for Figs 1 and 2

BLOCK NO.	DESCRIPTION
I	supply references
II	sawtooth generator
III	control part
IV	pulse width modulator (PWM)
V	LED control
VI	LED driver
VII	slow-start circuitry
VIII	over-voltage protection
IX	stand-by circuit
X	regulation-indicator output

These 10 functional blocks of Fig.1 and Fig.2 contain sub-sections numbered 1 to 28 which are

cross-referenced in the following description.

Supply references (Block I)

The TDA8385 is intended to be used on the secondary side of the self-oscillating power supply. It can be supplied either by an auxiliary winding of the transformer or an external supply e.g. 50 Hz transformer. Charging of the capacitor C_P (see Fig.16) takes place during transistor on-time (T_{on} ; see Fig.17). During stand-by the IC is supplied by the stand-by voltage V_{sb} (pin 10). The operating voltage range is from 7.5 to 20 V. The supply current, inclusive drive current for the LED, is less than 20 mA. A bandgap based reference (2.5 V) generates a stabilized voltage V_{stab} of 3.9 V to supply all internal circuits of the IC except the LED driver. The LED driver is directly supplied by V_P . The reference block generates all the reference voltages in the circuit. By means of a resistor connected to pin 3, a reference current (I_{ref}) is defined.

This current is reflected several times and is used to obtain IC-independent settings e.g. $T_{on(min)}$ setting, delay setting, charging and discharging of slow-start capacitor C_{ss} on pin 7 (see Fig.16).

The power supply is released by the power supply is released by the opto-coupler IC at an input voltage level, which is high enough to guarantee correct operation of the TDA8385 e.g. $V_P = 10$ V by sensing the mains voltage V_1 . As soon as the SOPS switching transistor (T1, see Fig.16) is conductive the capacitor C_P is charged. As long as the IC supply voltage is below 7.5 V the LED driver is blocked (see latch output; sub-section 28) in order to guarantee start-up of SOPS.

During the initialization phase the quick-discharge-switch (sub-section 27), set input of flip-flop (13) and reset input of flip-flop (23) are also activated. As soon as the voltage of 7.5 V is reached the control functions of the IC are operative. Hysteresis on the initialization level is 2.3 V.

Control circuit for a Self-Oscillating Power Supply (SOPS)

TDA8385

Sawtooth generator (Block II)

CURRENT SIMULATION
(SEE FIGS 5 AND 16)

The current of the power supply switching transistor is detected on the secondary side by an indirect method of current sensing.

Information of the collector current (I_c) is obtained by integrating the voltage of an auxiliary winding of the transformer during transistor on-time (T_{on}). An external capacitor C on pin 5 is charged during T_{on} by the current source I_{sim} . The current I_{sim} is the reflection of the current which flows into pin 12. This current is obtained by connecting an external resistor R12 to the auxiliary transformer winding. During transistor on-time this current is related to the input voltage V_I . During transistor off time (T_{off}) the capacitor C is discharged by switch sw1. This switch is active during the total T_{off} time. In this way a sawtooth voltage V_c is formed across C. This sawtooth is a measure for the collector current of the switching transistor T1.

For the voltage V_c yields:

$$V_c = \frac{I_{sim} \times T_{on}}{C} \quad (1)$$

$$I_{sim} = p \times \frac{n_h}{n_p} \times \frac{V_I}{R_{12}} \quad (2)$$

Where: p = reflection factor;

$$p = \frac{I_{sim}}{I_{12}} = 0.2$$

(2) \rightarrow (1) gives:

$$V_c = \frac{p}{C} \times \frac{n_h}{n_p} \times \frac{V_I}{R_{12}} \times T_{on} \quad (3)$$

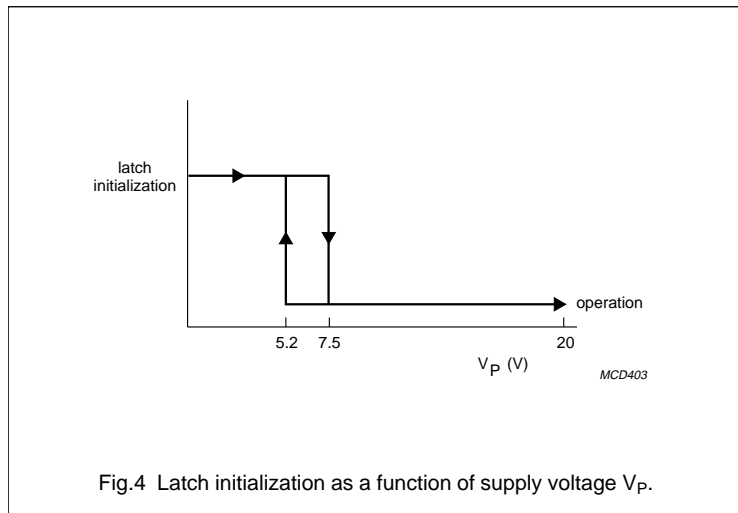

Fig.4 Latch initialization as a function of supply voltage V_p .

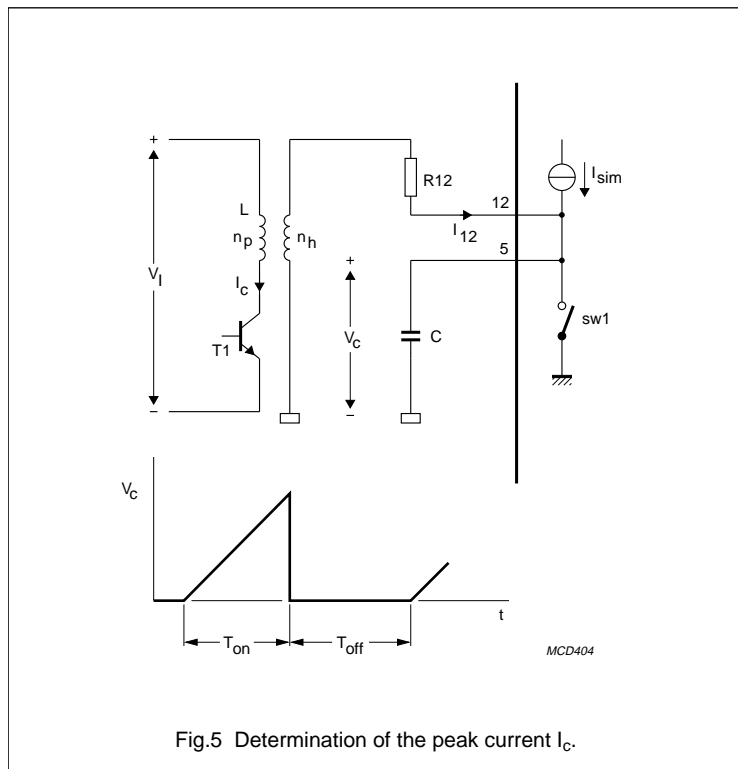

Fig.5 Determination of the peak current I_c .

Control circuit for a Self-Oscillating Power Supply (SOPS)

TDA8385

For 'T_{on}' yields:

$$T_{on} = \frac{V_c \times C \times n_p \times R12}{p \times n_h \times V_l} \quad (4)$$

For the primary current I_c yields:

$$I_c = \frac{V_l}{L} \times T_{on} \quad (5)$$

Substitution (4) into (5):

$$I_c = \frac{C}{L} \times \frac{1}{p} \times \frac{n_p}{n_h} \times R12 \times V_c \quad (6)$$

Equation (6) shows that by limiting the voltage V_c the collector peak current can be limited. The peak current is limited by means of the clamping circuit in the transfer character generator (TCG); see Fig.1 sub-section 4.

The clamping level can be externally influenced by means of a resistor on pin 7.

The collector peak current can be influenced in several ways:

- Resistor R12 on pin 12
- Capacitor C on pin 5
- Capacitor on pin 7
- Transfer ratio n_h/n_p
- Inductance L

Before comparing the sawtooth voltage V_c with the control voltage V_r in the pulse width modulator, a voltage of 100 mV is added to V_c. In this way it will be possible for V_r to become smaller than V_{sim}, which is important for a stabilized no-load operation (see Fig.6 area 3).

DEMAGNETIZATION INPUT (PIN 15)

This input prevents the switching transistor from conducting during demagnetization of the transformer in order to prevent the transformer from going into saturation. The output of comparator (11) is HIGH as soon as the voltage of the transformer winding exceeds 115 mV.

DELAY SETTING (PIN 6)

The output of sub-section 11 is extended by the delay circuit of sub-section 12. The starting (reference) point of the delay circuit is the falling edge of the output of demagnetizing comparator (11). The delay can be determined externally by capacitor (C_{delay}) on pin 6.

The switch-on moment of the switching transistor can be determined by capacitor C_{delay}.

A minimum delay time is required to prevent transistor T1 from switching during demagnetization of the transformer because of oscillations caused by the leakage inductance.

Control part (Block III)

The differential amplifier, sub-section 3, compares the feedback voltage (V_{fb}) with the reference voltage V_{ref}. The output of the differential amplifier is available on pin 11 to allow gain setting. The differential amplifier is internally compensated for 0 dB feedback stability.

The feedback input (pin 9) is also used as the input for the TCG (see Fig.6) with which a current foldback characteristic can be obtained as shown in Fig.7.

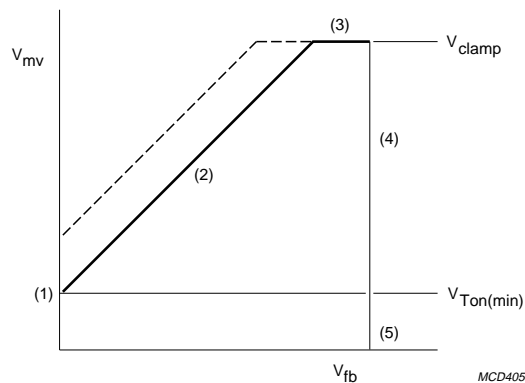

(1), (2), (3) = V_{TCG}.
(4), (5) = V_{diff}.

Fig.6 Reference voltage (V_{mv}) as a function of feedback voltage (V_{fb}).

Control circuit for a Self-Oscillating Power Supply (SOPS)

TDA8385

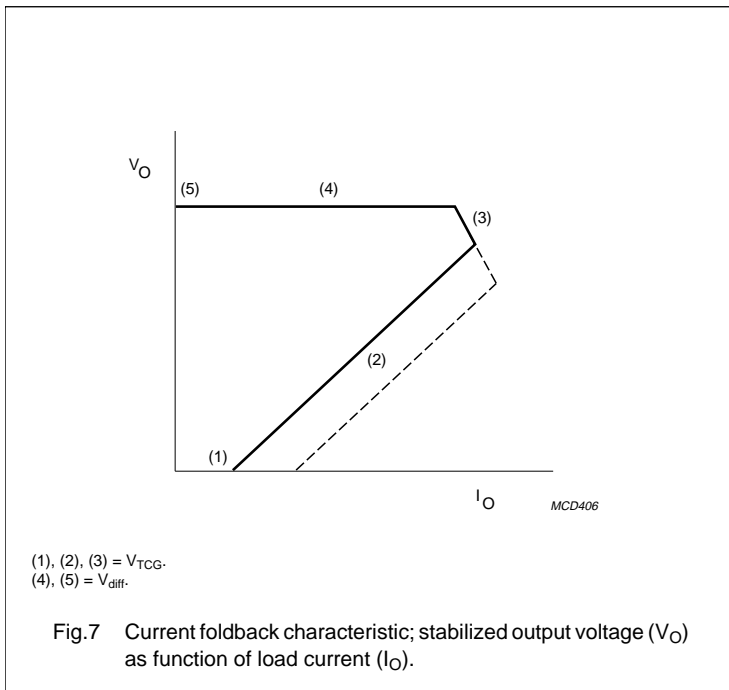

The voltage $V_{Ton(min)}$ determines the minimum on-time of the switching transistor. This voltage can be determined externally with a resistor on pin 4. With this resistor the current foldback characteristic can be influenced (see dotted line in Figs 6 and 7).

The minimum on-time is of importance for the following.

- Stand-by operation
- Starting-up of power supply
- Overload and short-circuit conditions.

The output of the differential amplifier (V_{diff}), the output of the TCG (V_{TCG}) and the voltage $V_{ss} + V_{Ton(min)}$ are compared in a minimum voltage clamping circuit (see Fig.1 sub-section 6). The output voltage is equal to the lowest input voltage.

Some relevant characteristics of the control part are depicted in Fig.8.

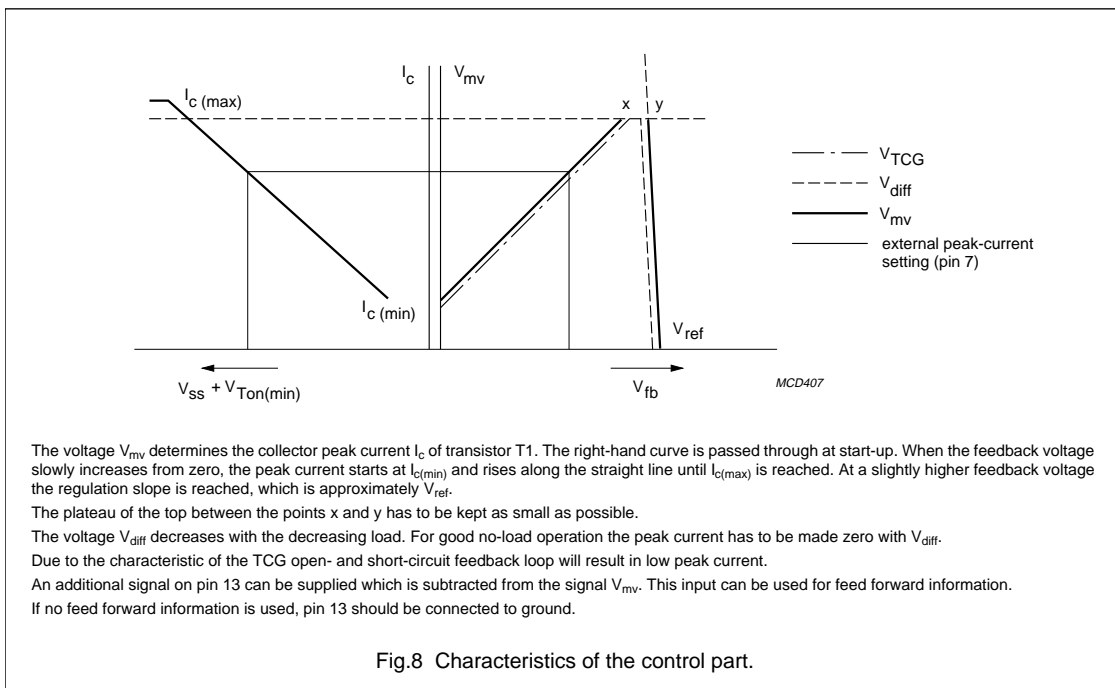

Control circuit for a Self-Oscillating Power Supply (SOPS)

TDA8385

Pulse width modulator (Block IV)

The pulse width modulator compares the control voltage V_r with the sawtooth voltage V_{sim} . If $V_{sim} > V_r$ output sub-section 8 is HIGH the LED is switched on and then the switching transistor is switched off. In this way the output voltage is controlled.

EXAMPLE

If the load decreases, V_O increases and therefore V_r decreases. This causes the LED to start conducting prematurely, which implies that the switching transistor is turned off sooner. The consequence is that the collector peak current decreases and hence less energy is stored in the transformer and V_O will decrease.

LED control (Block V)

If either output of sub-section 8 or output of sub-section 16 are HIGH the LED is conductive. In order to improve the start-up behaviour of the power supply, the demagnetization signal of sub-section 12 will only activate the LED driver if flip-flop (13) has previously been set. The set signal is generated in the following three ways.

1. Pulse width modulator (sub-section 8)
2. Comparator (18)
3. $V_{P(min)}$ detector

Set signal (2.) and (3.) are added as extra security to guarantee a demagnetization pulse in the event of the switching transistor not having enough base current. In that situation e.g. at start-up, no comparator signal, set signal (3.) is generated by sub-section 8.

LED driver (Block VI)

The LED driver (pin 2) is blocked if the supply voltage V_P is in the initialization phase (see Fig.4). The output stage is a push-pull stage, which can sink 5 mA and source 10 mA.

Slow-start circuit (Block VII)

The slow-start circuit is active at start-up, over voltage protection or after an overload (short-circuited), and stand-by mode. The voltage V_{SS} and therefore the voltage V_{mv} and the peak current I_c slowly increase at start-up.

By means of sub-section 27 the slow start voltage V_{SS} is clamped to the voltage V_{fb} . If the feedback voltage is reduced, e.g. as overload, the slow-start capacitor is discharged to the level of V_{fb} . In this way a slow start-up is also guaranteed after an overload, short-circuit situation or after a stand-by mode. The circuit of sub-section 27 is not active during an over voltage protection.

When the supply voltage V_P is below the reset-level of 5.2 V (sub-section 28) the slow-start capacitor is quickly discharged.

The slow-start input (pin 7) can also be used for $I_{c(max)}$ setting by connecting a resistor to this pin.

Over voltage protection (Block VIII)

The operation of the over voltage protection circuit is, in the event of the IC being SOPS-supplied, quite different from when the IC is externally supplied.

OPERATION WHEN THE IC IS EXTERNALLY SUPPLIED

When the voltage on pin 8 exceeds 2.5 V the slow-start capacitor is slowly discharged. During discharge the LED is permanently conducting. Discharge is stopped when V_{SS} is below 115 mV. Flip-flop (23) will then be reset and the circuit is ready again for a new slow-start procedure.

During an over voltage sub-section 27 is not active so that the output voltage V_O cannot influence the slow-start discharge procedure.

OPERATION WHEN IC IS SOPS-SUPPLIED (SEE FIGS 9 AND 10)

When the voltage on pin 8 exceeds 2.5 V the slow-start capacitor is slowly discharged. During discharge of C_{SS} the supply capacitor C_P is also discharged. Because the capacitors C_P and C_{SS} have almost the same value and the supply current I_P (≈ 15 mA) is much larger than the slow discharge current (≈ 50 μ A), the LED will be switched off by means of the $V_{P(min)}$ detection circuit (5.2 V). At that moment the switching transistor will be switched on again until the 7.5 V level is reached. During this hysteresis interval the slow-charge capacitor is quickly discharged. At the 7.5 V level the LED will be switched on again because flip-flop (23) output is still HIGH.

The same procedure will be repeated several times until the slow-start capacitor reaches the 115 mV reset level. At that moment the slow-start procedure is started again.

If there is still an over voltage the procedure will be repeated.

Figure 10 is a detailed exposure of Fig.11.

Control circuit for a Self-Oscillating Power Supply (SOPS)

TDA8385

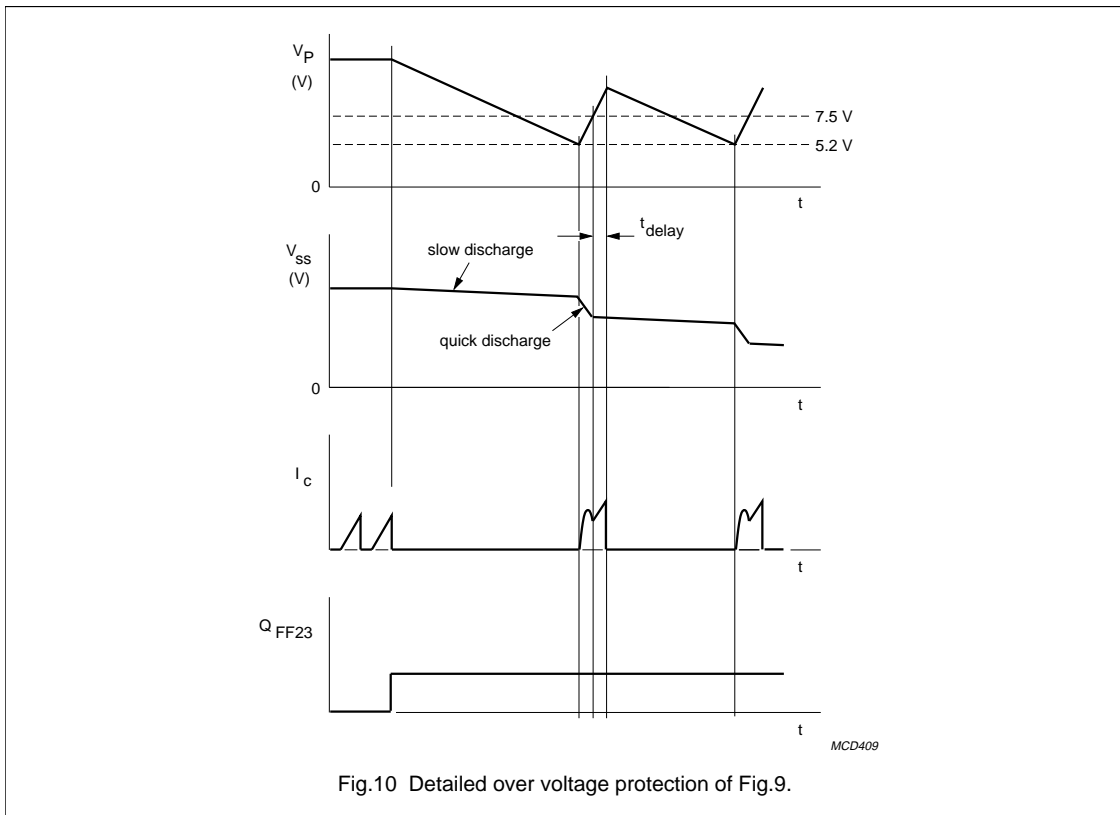
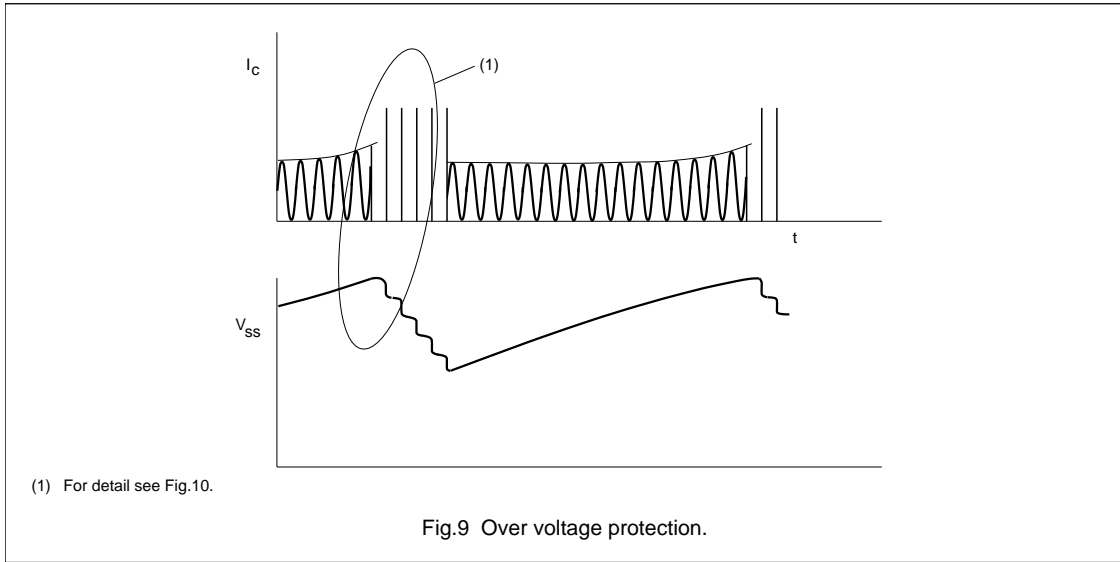

Control circuit for a Self-Oscillating Power Supply (SOPS)

TDA8385

Stand-by circuit (Block IX)

During stand-by operation the voltage V_{sb} is supplied from the SOPS via thyristor TH1 (see Fig.16). In the stand-by state, SOPS operates in a burst mode. When the voltage on pin 10 exceeds 2.5 V the LED driver is permanently activated. The LED driver is released again if the voltage is below 2 V (see Fig.11).

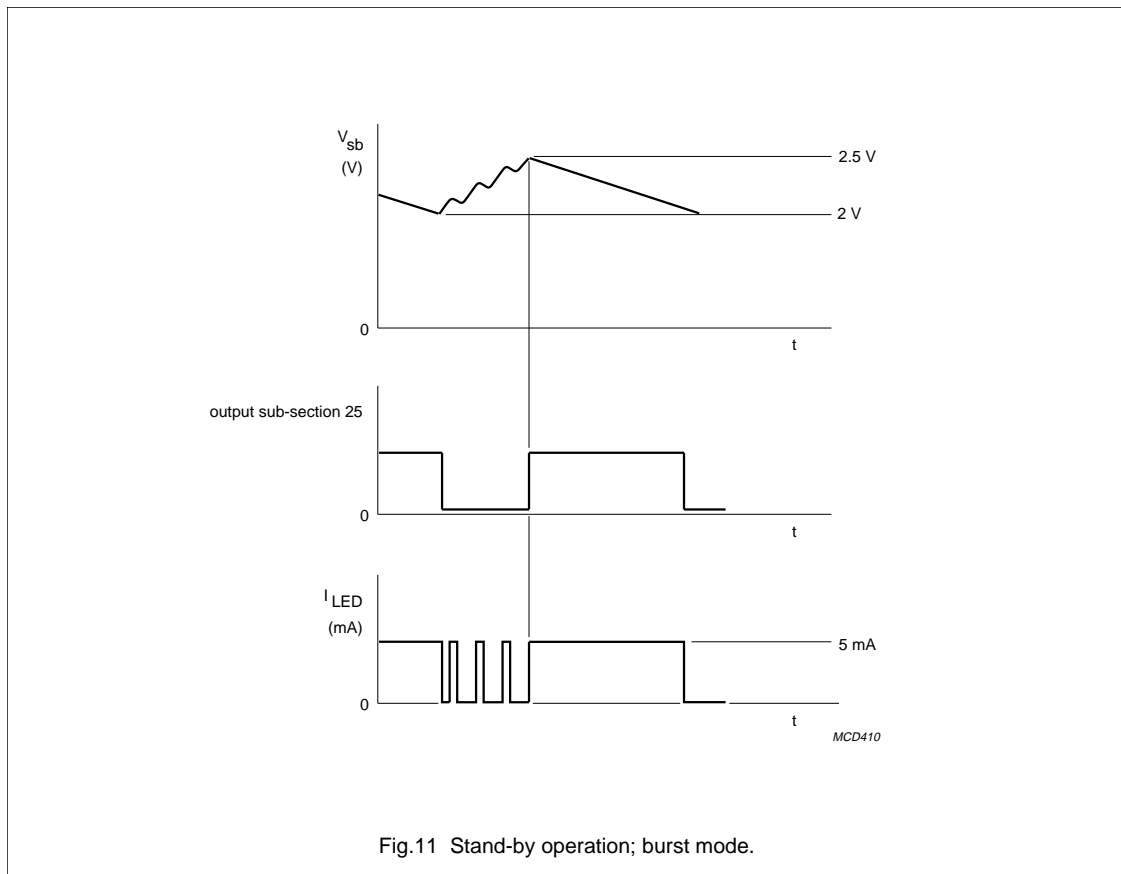

Fig.11 Stand-by operation; burst mode.

Control circuit for a Self-Oscillating Power Supply (SOPS)

TDA8385

Regulation indicator output (Block X)

Pin 1 can be used to reset the logic circuit in the TV receiver at power on and off. Sub-section 29 has an open-collector output. The output of this block is LOW during the regulation mode ($V_{diff} < V_{ts}$; see Fig.12).

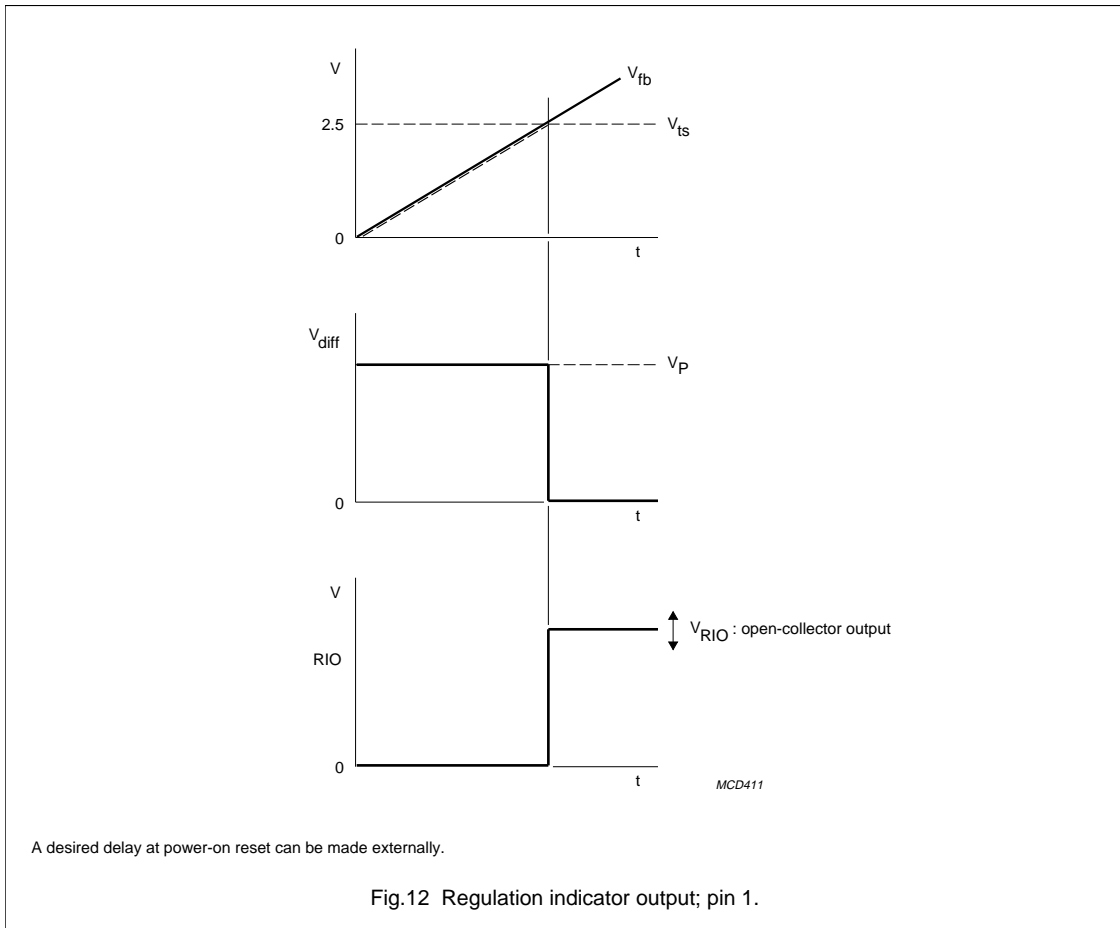

Control circuit for a Self-Oscillating Power Supply (SOPS)

TDA8385

LIMITING VALUES

In accordance with the Absolute Maximum Rating System (IEC 134).

All voltages are measured with respect to ground; positive current flow into the IC; all pins not mentioned in the voltage list are not allowed to be voltage driven. The voltage ratings are valid provided other ratings are not violated; current ratings are valid provided the power rating is not violated.

SYMBOL	PARAMETER	CONDITIONS	MIN.	MAX.	UNIT
Voltages					
V_P	supply voltage	pin 2 connected	-0.5	20	V
		pin 2 open-circuit	-0.5	18	V
V_n	voltage on pins 1, 2, 4, 7, 9 and 13		-0.5	+18	V
V_3	voltage on pin 3		-0.5	+6	V
$V_{8,10}$	voltage on pins 8 and 10		-0.5	+3.9	V
V_{12}	voltage on pin 12		-0.1	+0.5	V
V_{15}	voltage on pin 15		-0.5	+0.5	V
Currents					
I_1	current on pin 1		0	2	mA
I_n	current on pins 2, 12 and 15		-10	+10	mA
I_3	current on pin 3		-1	0	mA
$I_{5,6}$	current on pins 5 and 6		-1	+1	mA
I_7	current on pin 7		-1	+25	mA
I_{11}	current on pin 11		-10	+0.5	mA
I_{16}	current on pin 16		0	20	mA
Temperatures					
T_{amb}	operating ambient temperature		-25	+70	°C
T_{stg}	storage temperature		-55	+150	°C
Power dissipation					
P_{tot}	total power dissipation		-	500	mW

THERMAL RESISTANCE

SYMBOL	PARAMETER	THERMAL RESISTANCE
$R_{th\ j-a}$	from junction to ambient in free air	55 K/W

Control circuit for a Self-Oscillating Power Supply (SOPS)

TDA8385

CHARACTERISTICS

$V_P = 15\text{ V}$; $I_3 = 200\ \mu\text{A}$; $T_{\text{amb}} = 25\text{ }^\circ\text{C}$; unless otherwise specified.

SYMBOL	PARAMETER	CONDITIONS	MIN.	TYP.	MAX.	UNIT
Supply						
V_P	supply voltage (pin 16)		7.9	–	20	V
V_{16}	supply initialization level		7.1	7.5	7.9	V
$V_{16(\text{hys})}$	internal fixed hysteresis		2.5	–	2.55	V
I_{16}	supply current	active LED output	–	–	20	mA
V_{11}	supply voltage ripple rejection	see Figs 13 and 14	–	60	–	mV
Reference voltage						
V_3	reference voltage at pin 3		0.52	0.55	0.58	V
Error amplifier						
V_9	threshold voltage error amplitude		2.4	2.5	2.6	V
I_9	input current feedback input		–	–	0.5	μA
I_{11}	sink current output	$V_{11} = 80\text{ mV}$	400	–	–	μA
I_{11}	source current output	$V_{11} = 2.5\text{ V}$	500	–	–	μA
G_o	open loop gain		–	100	–	dB
B	unity gain bandwidth		–	600	–	kHz
$\Delta V_9/\Delta T$	temperature coefficient		–	$\pm 300 \times 10^{-6}$	–	K^{-1}
V_5	threshold for switching output	$V_{\text{diff}} = 1.25\text{ V}$; $V_4 = 2\text{ V}$; $V_{13} = 0\text{ V}$; $V_7 > V_9$; $I_2 = 2\text{ mA}$	–	$V_{\text{diff}} - V_{\text{os}}^{(1)}$	–	V
Transfer characteristic generator						
I_4/I_3	current ratio	$V_4 = 0.5\text{ V}$	0.23	0.25	0.27	
V_5	threshold for switching output	$V_4 = 0.5\text{ V}$; $V_{13} = 0\text{ V}$; $V_7 > V_9$; $I_2 = 2\text{ mA}$				
	$T_{\text{on}(\text{min})}$	$V_9 = 0\text{ V}$	$0.4 - V_{\text{os}}$	$0.5 - V_{\text{os}}$	$0.6 - V_{\text{os}}$	V
	$V_{\text{fb}} = 20\%$	$V_9 = 0.4\text{ V}$	–	$0.9 - V_{\text{os}}$	–	V
	$V_{\text{fb}} = 50\%$	$V_9 = 1\text{ V}$	$1.4 - V_{\text{os}}$	$1.5 - V_{\text{os}}$	$1.6 - V_{\text{os}}$	V
	$V_{\text{fb}} = 80\%$	$V_9 = 1.6\text{ V}$	–	$2.1 - V_{\text{os}}$	–	V
	clamp	$V_9 = 2.25\text{ V}$	$2.4 - V_{\text{os}}$	–	$2.6 - V_{\text{os}}$	V
t_{PLH}	response time pulse width modulation pin 5 to pin 2 LOW-to-HIGH	note 2	–	–	700	ns
t_{PHL}	response time pulse width modulation pin 5 to pin 2 HIGH-to-LOW	note 2	–	–	1	μs
Feed forward						
V_5	threshold for switching output (V_{io})	$V_4 = 0.5\text{ V}$; $V_{13} = 0\text{ V}$; $V_7 = V_9 = 3\text{ V}$; $I_2 = 2\text{ mA}$; $V_{11} = 1\text{ V}$	$0.6 - V_{\text{os}}$	$0.7 - V_{\text{os}}$	$0.8 - V_{\text{os}}$	V
I_{13}	input bias current	$V_{13} = 0\text{ V}$	–	–	1	μA

Control circuit for a Self-Oscillating Power Supply (SOPS)

TDA8385

SYMBOL	PARAMETER	CONDITIONS	MIN.	TYP.	MAX.	UNIT
Slow-start						
I_7/I_3	charge current ratio	$V_7 = 0.5 \text{ V}$	0.22	0.24	0.26	
I_7	quick discharge current	$V_7 = 1 \text{ V}$	20	–	–	mA
		$V_7 = 100 \text{ mV}$	50	–	–	μA
V_7	clamping level	$I_7 = 100 \mu\text{A}$	2.8	3.0	3.2	V
V_5	threshold for switching output (V_{ss})	$V_4 = 0.5 \text{ V}$; $V_{13} = 0 \text{ V}$; $V_7 = 1 \text{ V}$; $I_2 = 2 \text{ mA}$; $V_9 = 2 \text{ V}$	$1.4 - V_{\text{os}}$	$1.5 - V_{\text{os}}$	$1.6 - V_{\text{os}}$	V
Output stage						
$V_{2(\text{sat})}$	saturation voltage	$I_2 = 2 \text{ mA}$	–	–	300	mV
I_2	source current	$V_2 = 2 \text{ V}$	–	–	–	–
	operating		4.8	5.3	6.3	mA
	initialization phase		–	–	50	μA
V_2	open output voltage HIGH	$I_2 = 5 \text{ mA}$	12	–	–	V
Current simulation						
I_5/I_{12}	current ratio	$V_5 = 1 \text{ V}$; $I_{12} = 0.5 \text{ mA}$	0.19	0.2	0.21	
V_{12}	simulation input voltage	$I_{12} = 0.5 \text{ mA}$	–	–	1.1	V
$V_{5(\text{sat})}$	saturation voltage	$V_{15} = V_6 = 0 \text{ V}$; $I_5 = 1 \text{ mA}$	–	–	300	mV
		$V_{15} = V_6 = 0 \text{ V}$; $I_5 = 200 \mu\text{A}$	–	–	200	mV
ΔV	threshold for switching output; voltage difference between pins 5 and 11; offset simulation voltage (V_{os})	$V_4 = 0.5 \text{ V}$; $V_{13} = 0 \text{ V}$; $V_7 = V_9 = 3 \text{ V}$; $I_2 = 2 \text{ mA}$; $V_{11} = 0.5 \text{ V}$	60	100	140	mV
Demagnetization input						
t_{demLH}	delay from pin 15 to pin 5 LOW-to-HIGH	see Fig.15; pin 6 not connected	–	–	500	ns
t_{demHL}	delay from pin 15 to pin 5 HIGH-to-LOW	see Fig.15	–	–	1	μs
V_{15}	clamping level	$I_{15} = 10 \text{ mA}$	–	–	–	–
	positive		–	–	1.2	V
	negative		–	–	–1	V
V_{15}	demagnetization threshold voltage		90	115	140	mV
C_{15}	input capacitance		–	–	10	pF
I_{15}	input bias current	$V_{15} = 60 \text{ mV}$	–	–	0.5	μA

Control circuit for a Self-Oscillating Power Supply (SOPS)

TDA8385

SYMBOL	PARAMETER	CONDITIONS	MIN.	TYP.	MAX.	UNIT
Delay setting						
I_6/I_3	charge current ratio	$V_6 = 1 \text{ V}$	1.1	1.2	1.3	
I_6	charge current initialization phase	$V_6 = 1 \text{ V}; V_{16} = 5 \text{ V}$	2	–	–	mA
V_6	clamping level		2.8	–	3.2	V
$V_{6(\text{sat})}$	saturation voltage	$V_{15} = 140 \text{ mV}$	–	50	100	mV
t_{dLH}	delay from pin 6 to pin 2; V_6 crossing the 2.5 V level; LOW-to-HIGH	$C_6 = 470 \text{ pF};$ $V_5 = 0 \text{ V}; I_2 = 2 \text{ mA};$ V_{15} see Fig.15; excluding capacitive tolerances	–	–	1.2	μs
t/c	delay setting ($t = C_6 \times V/I$)	$V_6 = 2.5 \text{ V};$ $I_3 = 250 \mu\text{A}$	–	10	–	ns/pF
Stand-by						
$V_{10\text{H}}$	threshold level HIGH		2.4	2.5	2.6	V
$V_{10(\text{hys})}$	hysteresis		450	500	550	mV
t_{dLH}	delay to output pin 10 to pin 2 LOW-to-HIGH		–	–	1	μs
t_{dHL}	delay to output pin 10 to pin 2 HIGH-to-LOW		–	–	1	μs
I_{10}	input current	$V_{10} = 2.3 \text{ V}$	–	–	5	μA
Over voltage protection						
V_8	threshold level		2.4	2.5	2.6	V
t_{dLH}	delay to output pin 8 to pin 2 LOW-to-HIGH		–	–	1	μs
t_{dHL}	delay to output pin 8 to pin 2 HIGH-to-LOW		–	–	1	μs
V_7	reset level		90	–	140	mV
I_7/I_3	slow discharge current ratio	$V_7 = 1 \text{ V}$	0.12	0.23	0.31	
I_8	input current	$V_8 = 3 \text{ V}$	–	–	1	μA
Regulation indicator output						
V_1	saturation voltage	$I_1 = 1 \text{ mA}$	–	–	300	mV
I_1	leakage current	$V_1 = V_{16}$	–	–	1	μA

Notes

- $V_{\text{os}} = V_{\text{offset}}$.
- V_5 pulse = 1 V; $V_4 = 0.5 \text{ V}; V_9 = V_7 = 3 \text{ V}; V_{11} = 0.5 \text{ V}; V_{13} = 0 \text{ V}; I_2 = 2 \text{ mA}$.

Control circuit for a Self-Oscillating Power Supply (SOPS)

TDA8385

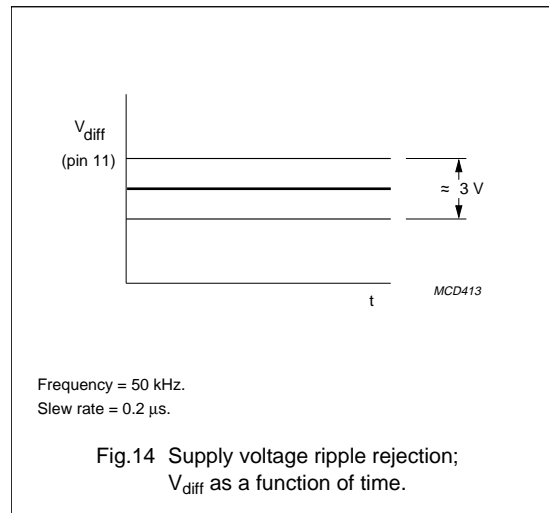
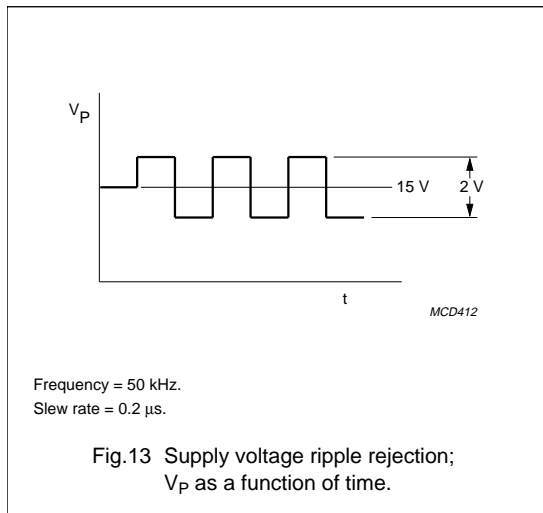

Table 1 Condition of test circuit used for Figs 13 and 14.

PINS	STATUS
1, 2, 4 to 6, 12, 13	not connected
8 to 10, 14, 15	ground
3	$R_{ref} = 2.7 \text{ k}\Omega$
7	$C_{ss} = 4.7 \text{ }\mu\text{F}$
16	V_P ; see Fig.13
11	V_{diff} ; see Fig.14

Control circuit for a Self-Oscillating Power Supply (SOPS)

TDA8385

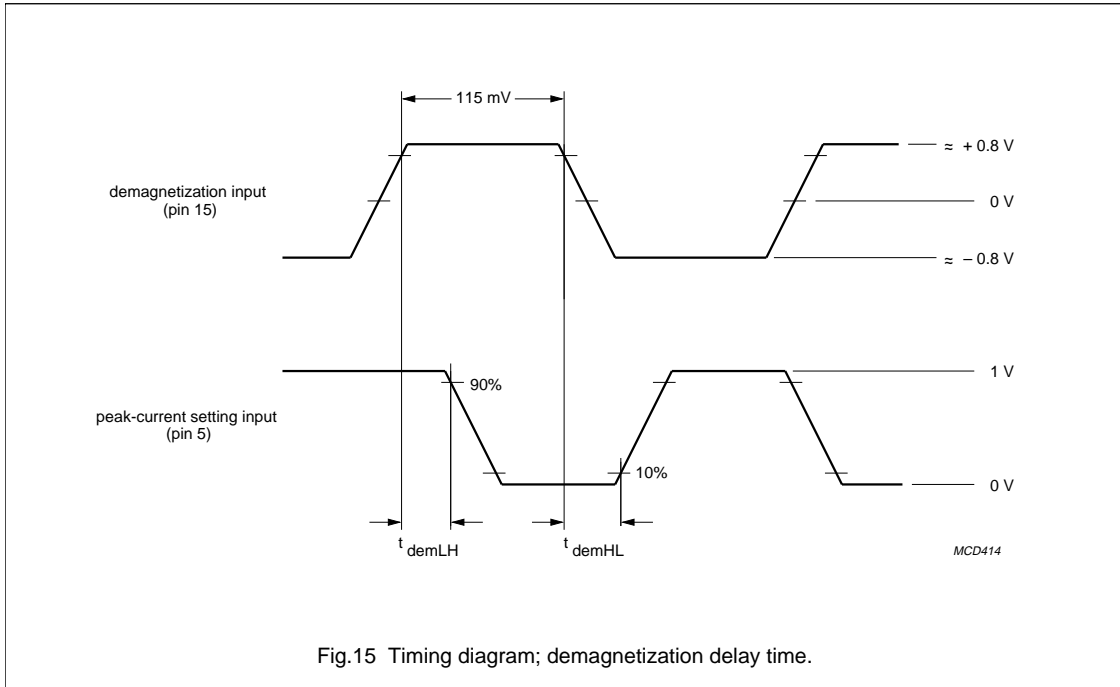

Fig.15 Timing diagram; demagnetization delay time.

Control circuit for a Self-Oscillating Power Supply (SOPS)

TDA8385

APPLICATION INFORMATION

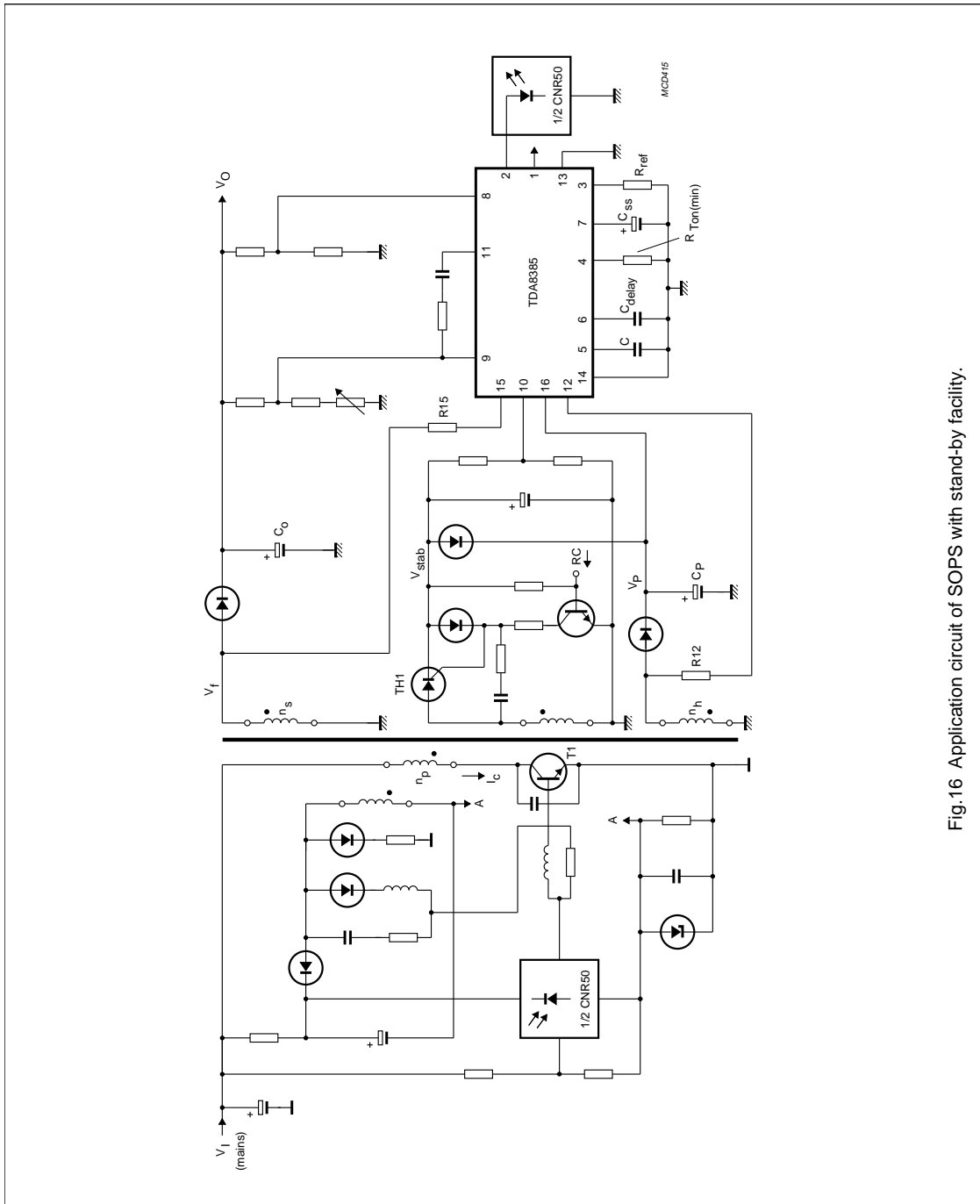

Fig. 16 Application circuit of SOPS with stand-by facility.

Control circuit for a Self-Oscillating Power Supply (SOPS)

TDA8385

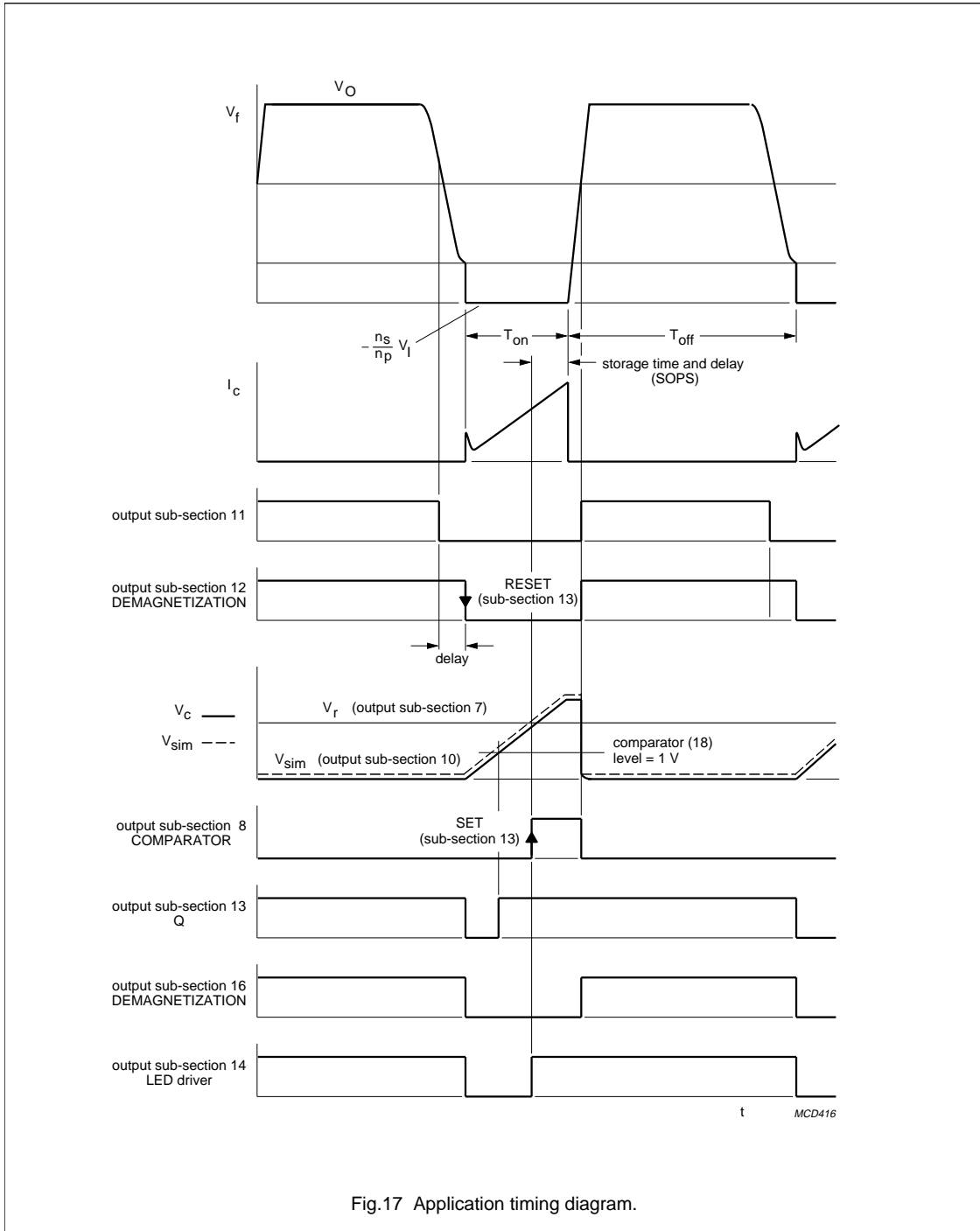
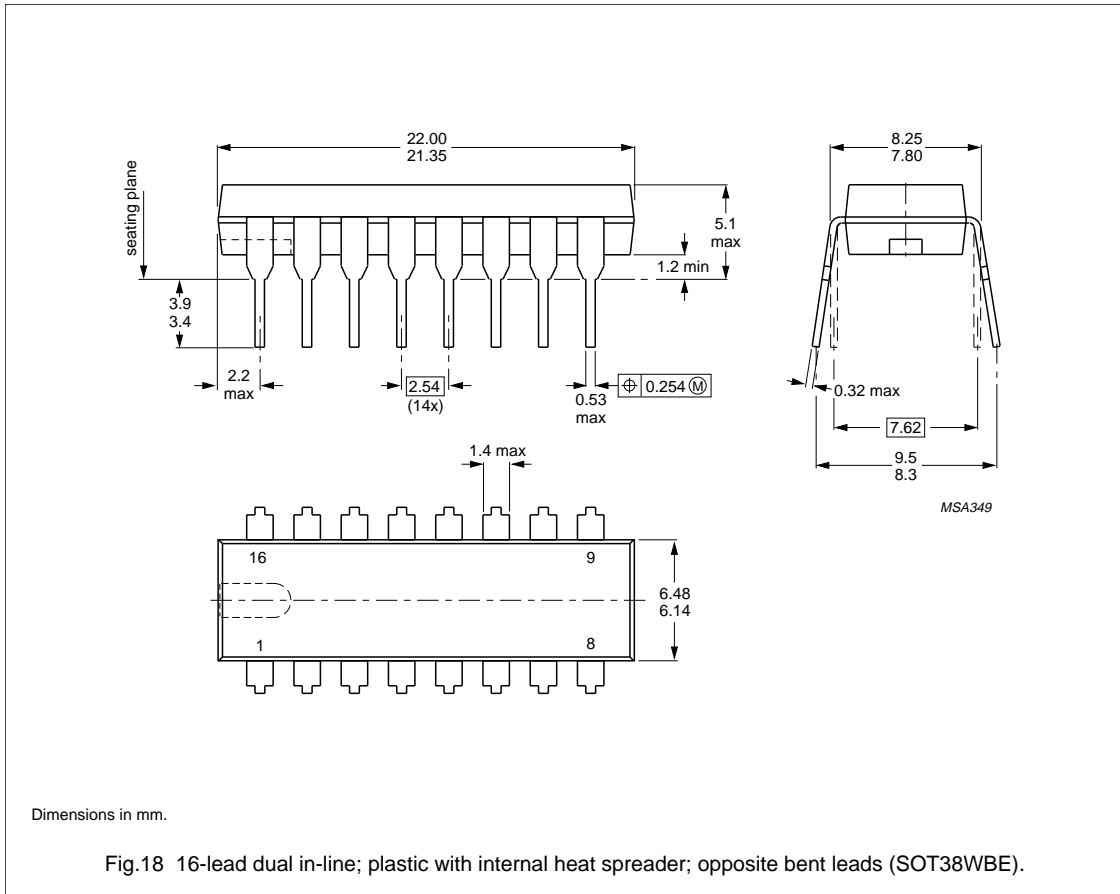

Fig.17 Application timing diagram.

Control circuit for a Self-Oscillating
Power Supply (SOPS)

TDA8385

PACKAGE OUTLINE



Control circuit for a Self-Oscillating Power Supply (SOPS)

TDA8385

SOLDERING

Plastic dual in-line packages

BY DIP OR WAVE

The maximum permissible temperature of the solder is 260 °C; this temperature must not be in contact with the joint for more than 5 s. The total contact time of successive solder waves must not exceed 5 s.

The device may be mounted up to the seating plane, but the temperature of the plastic body must not exceed the specified storage maximum. If the printed-circuit board has been pre-heated, forced cooling may be necessary immediately after soldering to keep the temperature within the permissible limit.

REPAIRING SOLDERED JOINTS

Apply a low voltage soldering iron below the seating plane (or not more than 2 mm above it). If its temperature is below 300 °C, it must not be in contact for more than 10 s; if between 300 and 400 °C, for not more than 5 s.

DEFINITIONS

Data sheet status	
Objective specification	This data sheet contains target or goal specifications for product development.
Preliminary specification	This data sheet contains preliminary data; supplementary data may be published later.
Product specification	This data sheet contains final product specifications.
Limiting values	
Limiting values given are in accordance with the Absolute Maximum Rating System (IEC 134). Stress above one or more of the limiting values may cause permanent damage to the device. These are stress ratings only and operation of the device at these or at any other conditions above those given in the Characteristics sections of the specification is not implied. Exposure to limiting values for extended periods may affect device reliability.	
Application information	
Where application information is given, it is advisory and does not form part of the specification.	

LIFE SUPPORT APPLICATIONS

These products are not designed for use in life support appliances, devices, or systems where malfunction of these products can reasonably be expected to result in personal injury. Philips customers using or selling these products for use in such applications do so at their own risk and agree to fully indemnify Philips for any damages resulting from such improper use or sale.