

16-bit Proprietary Microcontroller

CMOS

F²MC-16LX MB90370/375 Series

MB90372/F372/F377/V370

■ DESCRIPTION

The MB90370/375 series is a line of general-purpose, 16-bit microcontrollers designed for those applications which require high-speed real-time processing. The instruction set is designed to be optimized for controller applications which inheriting the AT architecture of F²MC-16LX series and allow a wide range of control tasks to be processed efficiently at high speed.

A built-in LPC interface, serial IRQ and PS/2 interface simplifies communication with host CPU and PS/2 devices in computer system. Moreover, SMBus compliant I²C*2, comparator for battery control and A/D converter implements the smart battery control. With these features, the MB90370/375 series matches itself as keyboard controller with smart battery control.

(Continued)

■ PACKAGE

144-pin plastic LQFP

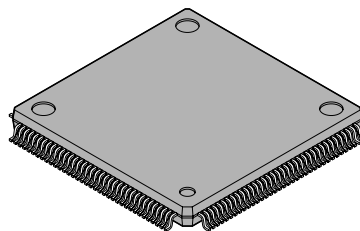

(FPT-144P-M12)

MB90370/375 Series

(Continued)

While inheriting the AT architecture of the F²MC*¹ family, the instruction set for the F²MC-16LX CPU core of the MB90370/375 series incorporates additional instructions for high-level languages, supports extended addressing modes, and contains enhanced multiplication and division instructions as well as a substantial collection of improved bit manipulation instructions. In addition, the MB90370 has an on-chip 32-bit accumulator which enables processing of long-word data.

*1 : F²MC stands for FUJITSU Flexible Microcontroller and a registered trademark of FUJITSU LIMITED.

*2 : Purchase of Fujitsu I²C components conveys a license under the Philips I²C Patent Rights to use, these components in an I²C system, provided that the system conforms to the I²C Standard Specification as defined by Philips.

■ FEATURES

- **Clock**
- Embedded PLL clock multiplication circuit
- Operating clock (PLL clock) can be selected from divided-by-2 of oscillation or one to four times the oscillation (at oscillation of 4 MHz to 16 MHz) .
- Minimum instruction execution time of 62.5 ns (at oscillation of 4 MHz, four times the PLL clock, operation at V_{CC} of 3.3 V)
- **CPU addressing space of 16M bytes**
- Internal 24-bit addressing
- **Instruction set optimized for controller applications**
- Rich data types (bit, byte, word, long word)
- Rich addressing mode (23 types)
- High code efficiency
- Enhanced precision calculation realized by the 32-bit accumulator
- **Instruction set designed for high level language (C) and multi-task operations**
- Adoption of system stack pointer
- Enhanced pointer indirect instructions
- Barrel shift instructions
- **Program patch function (2 address pointer)**
- **Improved execution speed**
- 4-byte instruction queue
- **Powerful interrupt function**
- Priority level programmable : 8 levels
- 32 factors of stronger interrupt function
- **Automatic data transmission function independent of CPU operation**
- Extended intelligent I/O service function (EI²OS)
- Maximum 16 channels
- **Low-power consumption (standby) mode**
- Sleep mode (mode in which CPU operating clock is stopped)
- Timebase timer mode (mode in which operations other than timebase timer and watch timer are stopped)
- Stop mode (mode in which all oscillations are stopped)
- CPU intermittent operation mode
- Watch mode
- **Package**
- LQFP-144 (FPT-144P-M12 : 0.4 mm pitch)
- **Process**
- CMOS technology

MB90370/375 Series

■ PRODUCT LINEUP

Part number Parameter	MB90V370	MB90F372	MB90F377	MB90372
Classification	—	Flash type ROM		Mask ROM
ROM size	—	64K Bytes		
RAM size	15.7K Bytes	6K Bytes		
CPU function	Number of instruction : 351 Minimum execution time : 62.5 ns / 4 MHz (PLL × 4) Addressing mode : 23 Data bit length : 1, 8, 16 bits Maximum memory space : 16M Bytes			
I/O port	I/O port (N-channel) : 16 I/O port (CMOS) : 72 I/O port (CMOS with pull-up control) : 32 Total : 120			
16-bit reload timer	Reload timer : 4 channels Reload mode, single-shot mode or event count mode selectable			
16-bit PPG timer	PPG timer : 3 channels PWM mode or single-shot mode selectable			
Bit decoder	Bit decoder : 1 channel			
Parity generator	Parity generator : 1 channel Selectable odd/even parity			
PS/2 interface	PS/2 interface : 3 channels 4 selectable sampling clocks			
LPC interface	LPC bus interface : 1 channel Universal peripheral Interface : 4 channels GA20 output control : for UPI channel 0 only Data buffer array : 48 bytes			
LPC Standby (able to work in Stop/TBT/Watch mode)	Yes	No	Yes	No
Serial IRQ controller	Serial IRQ request : 6 channels LPC clock monitor / control			
UART	With full-duplex double buffer (variable data length) Clock asynchronous or clock synchronized transmission (with start and stop bits) can be selectively used			
I ² C	I ² C (SMBus compliant) : 1 channel Support I ² C bus of Philips and the SMBus proposed by Intel Selectable packet error check Timeout detection function			
PC Arbitration under a particular condition*2	No	No	Yes	No

(Continued)

MB90370/375 Series

(Continued)

Part number	MB90V370	MB90F372	MB90F377	MB90372
Parameter				
Multi-address I ² C	Multi-address I ² C (SMBus compliant) : 1 channel Support I ² C bus of Philips and the SMBus proposed by Intel Selectable packet error check Timeout detection function 6 addresses support ALERT function			
Bridge circuit	Three bus connection routes can be switched by I ² C / multi-address I ² C			
Comparator	A comparator that can change the hysteresis width is contained Battery voltage, mounting/dismounting and instantaneous interruption can be detected Parallel and serial charging/discharging			
External interrupt	6 independent channels Selectable causes : Rise/fall edge, fall edge, "L" level or "H" level			
Key-on wake-up interrupt	8 independent channels Causes : "L" level			
8/10-bit A/D converter	8/10-bit resolution : 12 channels Conversion time : Less than 6.13 μs (16 MHz internal clock)			
8-bit D/A converter	8-bit resolution : 2 channels			
LCD controller/driver*3	Up to 9 SEG × 4 COM Selectable LCD output or CMOS I/O port		Without LCD controller/driver	Same as MB90F372
Low-power consumption	Stop mode / Sleep mode / CPU intermittent operation mode / Watch mode			
Process	CMOS			
Package	PGA256	LQFP-144 (FPT-144P-M12 : 0.4 mm pitch)		
Operating voltage	3.0 V to 3.6 V @ 16 MHz *1			

*1 : Varies with conditions such as the operating frequency (see Section "■ ELECTRICAL CHARACTERISTICS"), Assurance for the MB90V370 is given only for operation with a tool at power supply voltage of 3.0 V to 3.6 V, an operating temperature of 0 °C to +25 °C, and an operating frequency of 1 MHz to 16 MHz.

*2 : I²C can detect the arbitration lost when another I²C starts another communication at the same time.

*3 : After reset, PF5 to PF7 serve as general purpose I/O pins in MB90F377; however, these pins serve as V1, V2 and V3 function in other products.

MB90370/375 Series

■ PACKAGE AND CORRESPONDING PRODUCTS

Package	MB90V370	MB90F372	MB90F377	MB90372
PGA256	○	X	X	X
FPT-144P-M12	X	○	○	○

○ : Available

X : Not available

Note : For more information about each package, see Section “■ PACKAGE DIMENSIONS”.

■ DIFFERENCES AMONG PRODUCTS

Memory size

In evaluation with an evaluation product, note the difference between the evaluation product and the product actually used. The following items must be taken into consideration.

- The MB90V370 does not have an internal ROM, however, operations equivalent to chips with an internal ROM can be evaluated by using a dedicated development tool, enabling selection of ROM size by settings of the development tool.
- In the MB90V370, images from FF4000_H to FFFFFFF_H are mapped to bank 00, and FF0000_H to FF3FFF_H are mapped to bank FF only. (This setting can be changed by the development tool configuration.)
- In the MB90372/F372, images from FF4000_H to FFFFFFF_H are mapped to bank 00, and FF0000_H to FF3FFF_H are mapped to bank FF only.

MB90370/375 Series

• MB90F377

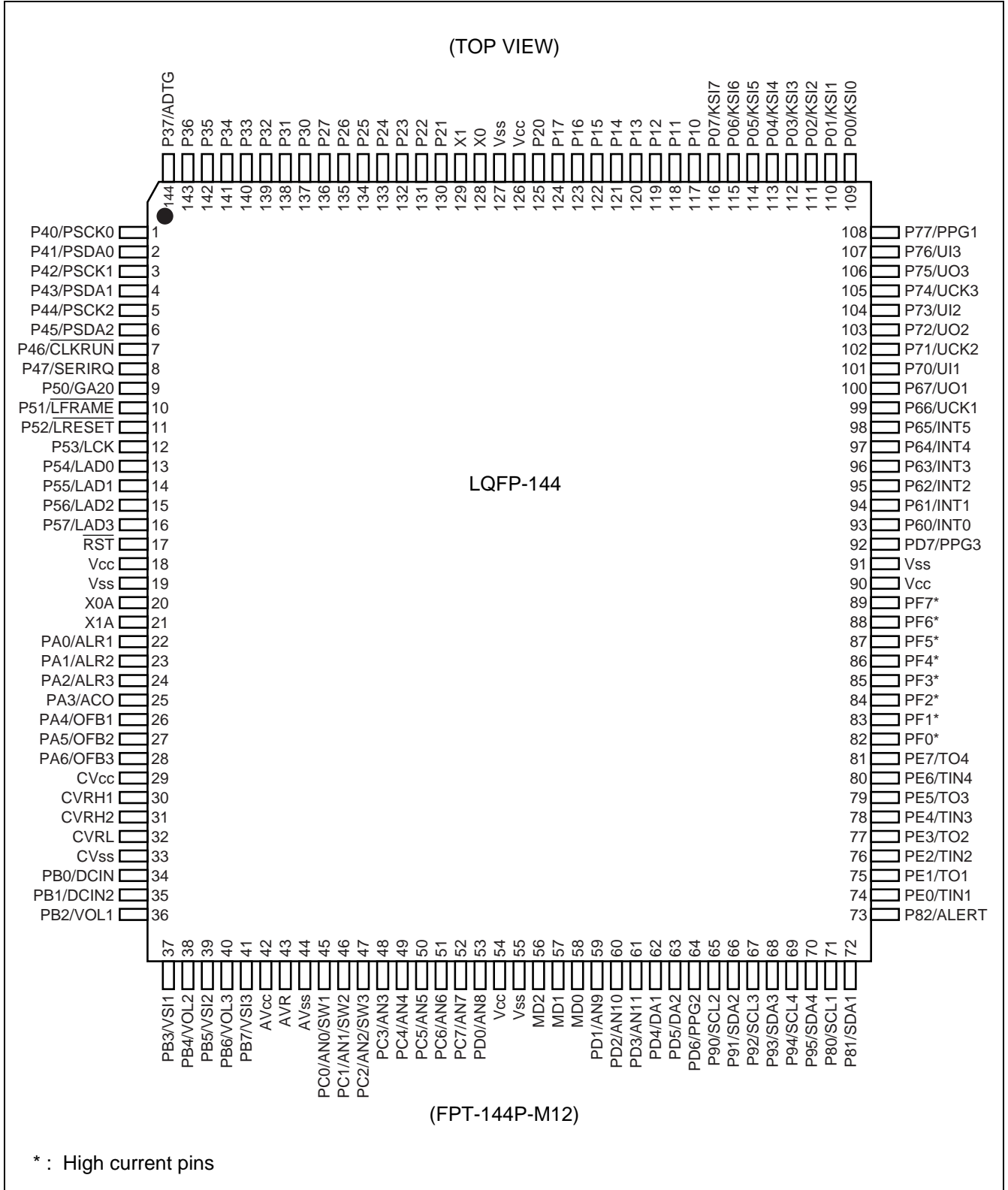

MB90370/375 Series

■ PIN DESCRIPTION

Pin no.	Pin name	I/O circuit	Pin status during reset	Function
LQFP-144				
128, 129	X0, X1	A	Oscillating	Main oscillation pins.
20, 21	X0A, X1A	A	Oscillating	Sub-clock oscillation pins.
17	RST	B	Reset input	External reset input pin.
58, 57, 56	MD0 to MD2	C	Mode input	Input pin for operation mode specification. Connect this pin directly to Vcc or Vss.
109 to 116	P00 to P07	D	Port input	General-purpose I/O ports.
	KSI0 to KSI7			Can be used as key-on wake-up interrupt input channel 0 to channel 7. Input is enabled when 1 is set in EICR : EN0 to EN7 in standby mode.
117 to 124	P10 to P17	E		General-purpose I/O ports.
125, 130 to 136	P20 to P27	E		General-purpose I/O ports.
137 to 143	P30 to P36	E		General-purpose I/O ports.
144	P37	E		General-purpose I/O ports.
	ADTG			External trigger input pin (ADTG) for the A/D converter.
1	P40	F		General-purpose N-ch open-drain I/O port.
	PSCK0			Serial clock I/O pin for PS/2 interface channel 0. This function is selected when PS/2 interface channel 0 is enabled.
2	P41	F		General-purpose N-ch open-drain I/O port.
	PSDA0			Serial data I/O pin for PS/2 interface channel 0. This function is selected when PS/2 interface channel 0 is enabled.
3	P42	F		General-purpose N-ch open-drain I/O port.
	PSCK1			Serial clock I/O pin for PS/2 interface channel 1. This function is selected when PS/2 interface channel 1 is enabled.
4	P43	F		General-purpose N-ch open-drain I/O port.
	PSDA1			Serial data I/O pin for PS/2 interface channel 1. This function is selected when PS/2 interface channel 1 is enabled.
5	P44	F		General-purpose N-ch open-drain I/O port.
	PSCK2		Serial clock I/O pin for PS/2 interface channel 2. This function is selected when PS/2 interface channel 2 is enabled.	
6	P45	F	General-purpose N-ch open-drain I/O port.	
	PSDA2		Serial data I/O pin for PS/2 interface channel 2. This function is selected when PS/2 interface channel 2 is enabled.	
7	P46	G	General-purpose N-ch open-drain I/O port.	
	CLKRUN		LPC clock status / restart request I/O pin for serial IRQ controller. This function is selected when serial IRQ and LPC clock restart request is enabled.	

(Continued)

MB90370/375 Series

Pin no. LQFP-144	Pin name	I/O circuit	Pin status during reset	Function
8	P47	H	Port input	General-purpose I/O port.
	SERIRQ			Serial IRQ data I/O pin for serial IRQ controller. This function is selected when serial IRQ is enabled.
9	P50	H		General-purpose I/O port.
	GA20			GA20 output for LPC interface. This function is selected when GA20 function is enabled.
10	P51	H		General-purpose I/O port.
	$\overline{\text{LFRAME}}$			LFRAME input for LPC interface. This function is selected when LPC interface is enabled.
11	P52	H		General-purpose I/O port.
	$\overline{\text{LRESET}}$			Reset input for LPC interface. This function is selected when LPC interface is enabled.
12	P53	H		General-purpose I/O port.
	LCK			Clock input for LPC interface. This function is selected when LPC interface is enabled.
13 to 16	P54 to P57	H		General-purpose I/O ports.
	LAD0 to LAD3			Address/Data I/O for LPC interface. This function is selected when LPC interface is enabled.
93 to 98	P60 to P65	I		General-purpose I/O ports.
	INT0 to INT5			Can be used as DTP/external interrupt request input channel 0 to 5. Input is enabled when 1 is set in ENIR : EN0 to EN5 in standby mode.
99	P66	I	General-purpose I/O port.	
	UCK1		Serial clock I/O pin for UART channel 1. This function is enabled when UART channel 1 enables clock output.	
100	P67	I	General-purpose I/O port.	
	UO1		Serial data output pin for UART channel 1. This function is enabled when UART channel 1 enables data output.	
101	P70	I	General-purpose I/O port.	
	UI1		Serial data input pin for UART channel 1. While UART channel 1 is operating for input, the input of this pin is used as required and must not be used for any other input.	
102	P71	I	General-purpose I/O port.	
	UCK2		Serial clock I/O pin for UART channel 2. This function is enabled when UART channel 2 enables clock output.	

(Continued)

MB90370/375 Series

Pin no. LQFP-144	Pin name	I/O circuit	Pin status during reset	Function
103	P72	I	Port input	General-purpose I/O port.
	UO2			Serial data output pin for UART channel 2. This function is enabled when UART channel 2 enables data output.
104	P73	I		General-purpose I/O port.
	UI2			Serial data input pin for UART channel 2. While UART channel 2 is operating for input, the input of this pin is used as required and must not be used for any other input.
105	P74	I		General-purpose I/O port.
	UCK3			Serial clock I/O pin for UART channel 3. This function is enabled when UART channel 3 enables clock output.
106	P75	I		General-purpose I/O port.
	UO3			Serial data output pin for UART channel 3. This function is enabled when UART channel 3 enables data output.
107	P76	I		General-purpose I/O port.
	UI3			Serial data input pin for UART channel 3. While UART channel 3 is operating for input, the input of this pin is used as required and must not be used for any other input.
108	P77	I		General-purpose I/O port.
	PPG1			Output pin for PPG channel 1. This function is enabled when PPG channel 1 output is enabled.
71	P80	T		General-purpose N-ch open-drain I/O port.
	SCL1			Serial clock I/O pin for multi-address I ² C.
72	P81	T		General-purpose N-ch open-drain I/O port.
	SDA1			Serial data I/O pin for multi-address I ² C.
73	P82	J		General-purpose N-ch open-drain I/O port.
	ALERT			ALERT output pin for multi-address I ² C.
65	P90	T	General-purpose N-ch open-drain I/O port.	
	SCL2		Serial clock I/O pin for bridge circuit.	
66	P91	T	General-purpose N-ch open-drain I/O port.	
	SDA2		Serial data I/O pin for bridge circuit.	
67	P92	T	General-purpose N-ch open-drain I/O port.	
	SCL3		Serial clock I/O pin for bridge circuit.	
68	P93	T	General-purpose N-ch open-drain I/O port.	
	SDA3		Serial data I/O pin for bridge circuit.	

(Continued)

MB90370/375 Series

Pin no.	Pin name	I/O circuit	Pin status during reset	Function	
LQFP-144					
69	P94	T	Port input	General-purpose N-ch open-drain I/O port.	
	SCL4			Serial clock I/O pin for bridge circuit.	
70	P95	T		General-purpose N-ch open-drain I/O port.	
	SDA4			Serial data I/O pin for bridge circuit.	
22 to 24	PA0 to PA2	H		General-purpose I/O ports.	
	ALR1 to ALR3			Alarm signal output when battery 1 to 3 run down in comparator circuit.	
25	PA3	H		General-purpose I/O port.	
	ACO			AC power set signal output in comparator circuit.	
26 to 28	PA4 to PA6	H		General-purpose I/O ports.	
	OFB1 to OFB3			Battery 1 to 3 discharge control signal output in comparator circuit.	
34, 35	PB0 to PB1	K		Comparator input	General-purpose I/O ports.
	DCIN to DCIN2				AC power monitoring input in comparator circuit.
36	PB2	K			General-purpose I/O ports.
	VOL1				Battery 1 power instantaneous interruption monitoring input in comparator circuit.
37	PB3	K	General-purpose I/O ports.		
	VSI1		Battery 1 indicator monitoring input in comparator circuit.		
38	PB4	K	General-purpose I/O ports.		
	VOL2		Battery 2 power instantaneous interruption monitoring input in comparator circuit.		
39	PB5	K	General-purpose I/O ports.		
	VSI2		Battery 2 indicator monitoring input in comparator circuit.		
40	PB6	K	General-purpose I/O ports.		
	VOL3		Battery 3 power instantaneous interruption monitoring input in comparator circuit.		
41	PB7	K	General-purpose I/O ports.		
	VSI3		Battery 3 indicator monitoring input in comparator circuit.		
45 to 47	PC0 to PC2	L	Comparator input or A/D input	General-purpose I/O ports.	
	SW1 to SW3			Battery 1 to 3 mount / dismount detection input in comparator circuit.	
	AN0 to AN2			A/D converter analog input pin 0 to 2. This function is enabled when the analog input specification is enabled (ADER1) .	

(Continued)

MB90370/375 Series

Pin no. LQFP-144	Pin name	I/O circuit	Pin status during reset	Function
48 to 52	PC3 to PC7	M	A/D input	General-purpose I/O ports.
	AN3 to AN7			A/D converter analog input pin 3 to 7. This function is enabled when the analog input specification is enabled (ADER1) .
53, 59 to 61	PD0 to PD3	M		General-purpose I/O ports.
	AN8 to AN11			A/D converter analog input pin 8 to 11. This function is enabled when the analog input specification is enabled (ADER2) .
62 to 63	PD4 to PD5	N	Port input	General-purpose I/O ports.
	DA1 to DA2			D/A converter analog output 1 to 2. This function is selected when D/A converter is enabled.
64, 92	PD6 to PD7	H		General-purpose I/O port.
	PPG2 to PPG3			Output pin for PPG channel 2 to 3. This function is selected when PPG channel 2 to 3 output is enabled.
74	PE0	O1 (O2 for MB90F377)		General-purpose I/O port.
	SEG0*1			Segment output pin for LCD controller/driver. This function is selected when LCD segment output is enabled.
	TIN1			External clock input pin for reload timer 1.
75	PE1	O1 (O2 for MB90F377)		General-purpose I/O port.
	SEG1*1			Segment output pin for LCD controller/driver. This function is selected when LCD segment output is enabled.
	TO1			Event output pin for reload timer 1.
76	PE2	O1 (O2 for MB90F377)		General-purpose I/O port.
	SEG2*1			Segment output pin for LCD controller/driver. This function is selected when LCD segment output is enabled.
	TIN2			External clock input pin for reload timer 2.
77	PE3	O1 (O2 for MB90F377)		General-purpose I/O port.
	SEG3*1			Segment output pin for LCD controller/driver. This function is selected when LCD segment output is enabled.
	TO2			Event output pin for reload timer 2.
78	PE4	O1 (O2 for MB90F377)	General-purpose I/O port.	
	SEG4*1		Segment output pin for LCD controller/driver. This function is selected when LCD segment output is enabled.	
	TIN3		External clock input pin for reload timer 3.	
79	PE5	O1 (O2 for MB90F377)	General-purpose I/O port.	
	SEG5*1		Segment output pin for LCD controller/driver. This function is selected when LCD segment output is enabled.	
	TO3		Event output pin for reload timer 3.	

(Continued)

MB90370/375 Series

(Continued)

Pin no. LQFP-144	Pin name	I/O circuit	Pin status during reset	Function
80	PE6	O1 (O2 for MB90F377)	Port input	General-purpose I/O port.
	SEG6*1			Segment output pin for LCD controller/driver. This function is selected when LCD segment output is enabled.
	TIN4			External clock input pin for reload timer 4.
81	PE7	O1 (O2 for MB90F377)		General-purpose I/O port.
	SEG7*1			Segment output pin for LCD controller/driver. This function is selected when LCD segment output is enabled.
	TO4			Event output pin for reload timer 4.
82	PF0	P1 (P2 for MB90F377)		General-purpose I/O port.
	SEG8*1			Segment output pin for LCD controller/driver. This function is selected when LCD segment output is enabled.
83 to 86	PF1 to PF4	P1 (P2 for MB90F377)		General-purpose I/O port.
	COM0 to COM3*2		COM output pin for LCD controller/driver. This function is selected when LCD COM output is enabled.	
87 to 89	PF5 to PF7	Q1 (Q2 for MB90F377)	Power input	General-purpose I/O port.
	V1 to V3*2			Power input pin for LCD controller/driver. This function is selected when external voltage divider is enabled.
42	AV _{cc}	R	Power input	V _{cc} power input pin for analog circuits.
43	AVR	S		V _{ref+} input pin for the A/D converter. This voltage must not exceed V _{cc} . V _{ref-} is fixed to AV _{SS} .
44	AV _{ss}	R		V _{ss} power input pin for analog circuits.
29	CV _{cc}	R	Power input	V _{cc} power input pin for analog circuits.
30	CVRH1	R		Standard power input pin of the comparator.
31	CVRH2	R		
32	CVRL	R		
33	CV _{ss}	R		V _{ss} power input pin for analog circuits.
19, 55, 91, 127	V _{ss}	–	Power input	Power (0 V) input pin.
18, 54, 90, 126	V _{cc}	–		Power (3.3 V) input pin.

*1 : It doesn't exist in MB90F377.

*2 : They don't exist in MB90F377.

MB90370/375 Series

I/O CIRCUIT TYPE

Type	Circuit	Remarks
A		<p>Main/Sub clock (main/sub clock crystal oscillator)</p> <ul style="list-style-type: none"> • High-rate oscillation feedback resistor of approximately 1 MΩ • Low-rate oscillation feedback resistor of approximately 10 MΩ
B		<ul style="list-style-type: none"> • Hysteresis input • Pull-up resistor approximately 50 kΩ
C		<ul style="list-style-type: none"> • Hysteresis input
D		<ul style="list-style-type: none"> • CMOS output • Hysteresis input • Selectable pull-up resistor approximately 50 kΩ • $I_{OL} = 4$ mA
E		<ul style="list-style-type: none"> • CMOS output • CMOS input • Selectable pull-up resistor approximately 50 kΩ • $I_{OL} = 4$ mA
F		<ul style="list-style-type: none"> • N-ch open-drain output • Hysteresis input • $I_{OL} = 4$ mA • 5 V tolerant

(Continued)

MB90370/375 Series

Type	Circuit	Remarks
G		<ul style="list-style-type: none"> • N-ch open-drain output • CMOS input • $I_{OL} = 4 \text{ mA}$
H		<ul style="list-style-type: none"> • CMOS output • CMOS input • $I_{OL} = 4 \text{ mA}$
I		<ul style="list-style-type: none"> • CMOS output • Hysteresis input • $I_{OL} = 4 \text{ mA}$
J		<ul style="list-style-type: none"> • N-ch open-drain output • CMOS input • $I_{OL} = 4 \text{ mA}$ • 5 V tolerant
K		<ul style="list-style-type: none"> • CMOS output • CMOS input • Comparator input • $I_{OL} = 4 \text{ mA}$

(Continued)

MB90370/375 Series

Type	Circuit	Remarks
L	<p> P-ch — Pout N-ch — Nout CMOS input Standby mode control Comparator input Analog input </p>	<ul style="list-style-type: none"> • CMOS output • CMOS input • Comparator input • A/D analog input • $I_{OL} = 4 \text{ mA}$
M	<p> P-ch — Pout N-ch — Nout CMOS input Standby mode control Analog input </p>	<ul style="list-style-type: none"> • CMOS output • CMOS input • A/D analog input • $I_{OL} = 4 \text{ mA}$
N	<p> P-ch — Pout N-ch — Nout CMOS input Standby mode control Analog input </p>	<ul style="list-style-type: none"> • CMOS output • CMOS input • D/A analog output • $I_{OL} = 4 \text{ mA}$
O1	<p> P-ch — Pout N-ch — Nout CMOS input Standby mode control Segment output </p>	<ul style="list-style-type: none"> • CMOS output • CMOS input • Segment output • $I_{OL} = 4 \text{ mA}$

(Continued)

MB90370/375 Series

Type	Circuit	Remarks
O2		<ul style="list-style-type: none"> • CMOS output • CMOS input • $I_{OL} = 4 \text{ mA}$
P1		<ul style="list-style-type: none"> • CMOS output • CMOS input • Segment output • $I_{OL} = 12 \text{ mA}$
P2		<ul style="list-style-type: none"> • CMOS output • CMOS input • $I_{OL} = 12 \text{ mA}$
Q1		<ul style="list-style-type: none"> • CMOS output • CMOS input • LCD driving power supply • $I_{OL} = 12 \text{ mA}$
Q2		<ul style="list-style-type: none"> • CMOS output • CMOS input • $I_{OL} = 12 \text{ mA}$

(Continued)

MB90370/375 Series

(Continued)

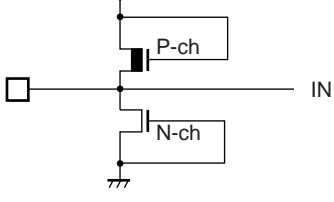
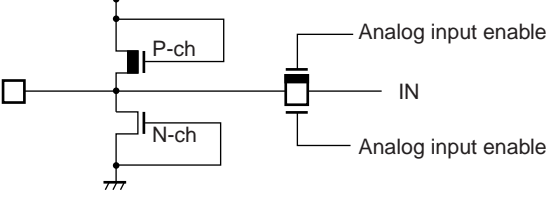
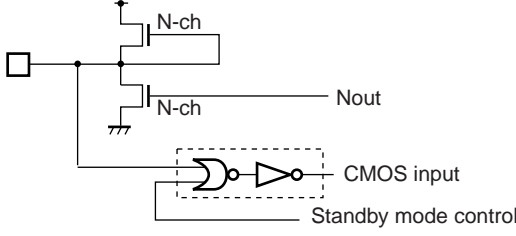
Type	Circuit	Remarks
R		<ul style="list-style-type: none"> • Power supply input protection circuit
S		<ul style="list-style-type: none"> • A/D converter reference voltage (AVR) input pin with protection circuit
T		<ul style="list-style-type: none"> • N-ch open-drain output • CMOS input • $I_{OL} = 4 \text{ mA}$ • 5 V tolerant

■ HANDLING DEVICES

- Be sure that the maximum rated voltage is not exceeded (latch-up prevention) .
A latch-up may occur on a CMOS IC if a voltage higher than V_{CC} or lower than V_{SS} is applied to an input or output pin other than medium-to-high voltage pins. A latch-up may also occur if a voltage higher than the rating is applied between V_{CC} and V_{SS} . A latch-up causes a rapid increase in the power supply current, which can result in thermal damage to an element. Take utmost care that the maximum rated voltage is not exceeded. When turning the power on or off to analog circuits, be sure that the analog supply voltages (AV_{CC} , CV_{CC} , AVR , $CVRH1$, $CVRH2$ and $CVRL$) and analog input voltage do not exceed the digital supply voltage (V_{CC}) .
- Stabilize the supply voltages
Even within the operation guarantee range of the V_{CC} supply voltage, a malfunction can be caused if the supply voltage undergoes a rapid change. For voltage stabilization guidelines, the V_{CC} ripple fluctuations (P-P value) at commercial frequencies (50 Hz to 60 Hz) should be suppressed to 10% or less of the reference V_{CC} value. During a momentary change such as when switching a supply voltage, voltage fluctuations should also be suppressed so that the transient fluctuation rate is 0.1 V/ms or less.
- Power-on
To prevent a malfunction in the built-in voltage drop circuit, secure 50 μ s (between 0.2 V and 1.8 V) or more for the voltage rise time during power-on.
- Treatment of unused input pins
An unused input pin may cause a malfunction if it is left open. Every unused input pin should be pulled up or down.
- Treatment of A/D converter, D/A converter and comparator power pin
When the A/D converter, D/A converter and comparator is not used, connect the pins as follows : $AV_{CC} = CV_{CC} = V_{CC}$, $AV_{SS} = AVR = CV_{SS} = CVRL = CVRH1 = CVRH2 = V_{SS}$.
- Notes on external clock
When an external clock is used, the oscillation stabilization wait time is required at power-on reset or at cancellation of sub-clock mode or stop mode. As shown in diagram below, when an external clock is used, connect only the X0 pin and leave the X1 pin open.

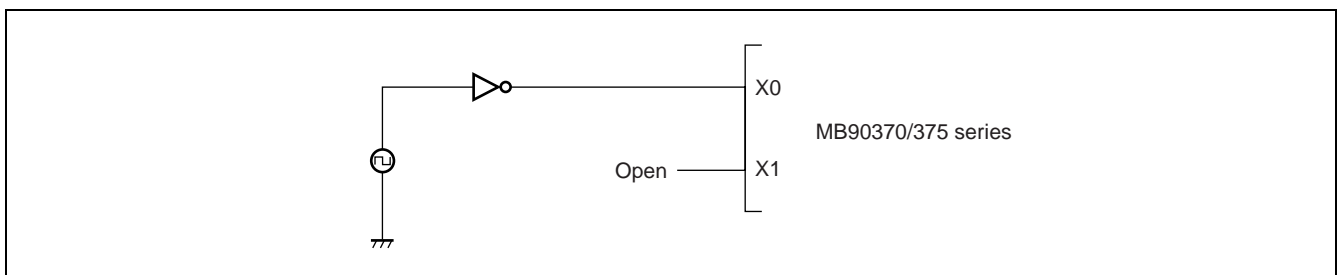

- Power supply pins
When a device has two or more V_{CC} or V_{SS} pins, the pins that should have equal potential are connected within the device in order to prevent a latch-up or other malfunction. To reduce extraneous emission, to prevent a malfunction of the strobe signal due to an increase in the group level, and to maintain the local output current rating, connect all these power supply pins to an external power supply and ground them.
The current source should be connected to the V_{CC} and V_{SS} pins of the device with minimum impedance. It is recommended that a bypass capacitor of about 0.1 μ F be connected near the terminals between V_{CC} and V_{SS} .

MB90370/375 Series

- Analog power-on sequence of A/D converter, D/A converter and comparator
The power to the A/D converter, D/A converter and comparator (AV_{CC} , CV_{CC} , AVR, CVRH1, CVRH2 and CVRL) and analog inputs (AN0 to AN11, VOL1 to VOL3, VSI1 to VSI3, SW1 to SW3, DCIN and DCIN2) must be turned on after the power to the digital circuits (V_{CC}) is turned on. When turning off the power, turn off the power to the digital circuits (V_{CC}) after turning off the power to the A/D converter, D/A converter, comparator and analog inputs. When the power is turned on or off, AVR should not exceed AV_{CC} . And CVRH1, CVRH2 and CVRL should not exceed CV_{CC} . Also, when a pin that is used for A/D analog input is used as an input port, the input voltage should not exceed AV_{CC} . And when comparator analog input is also used as an input port, the input voltage should not exceed CV_{CC} . (The power to the analog circuits and the power to the digital circuits can be simultaneously turned on or off.)
- Caution on Operations during PLL Clock Mode
If the PLL clock mode is selected, the microcontroller attempt to be working with the self-oscillating circuit even when there is no external oscillator or external clock input is stopped. Performance of this operation, however, cannot be guaranteed.

MB90370/375 Series

■ BLOCK DIAGRAM

• MB90372/F372/V370

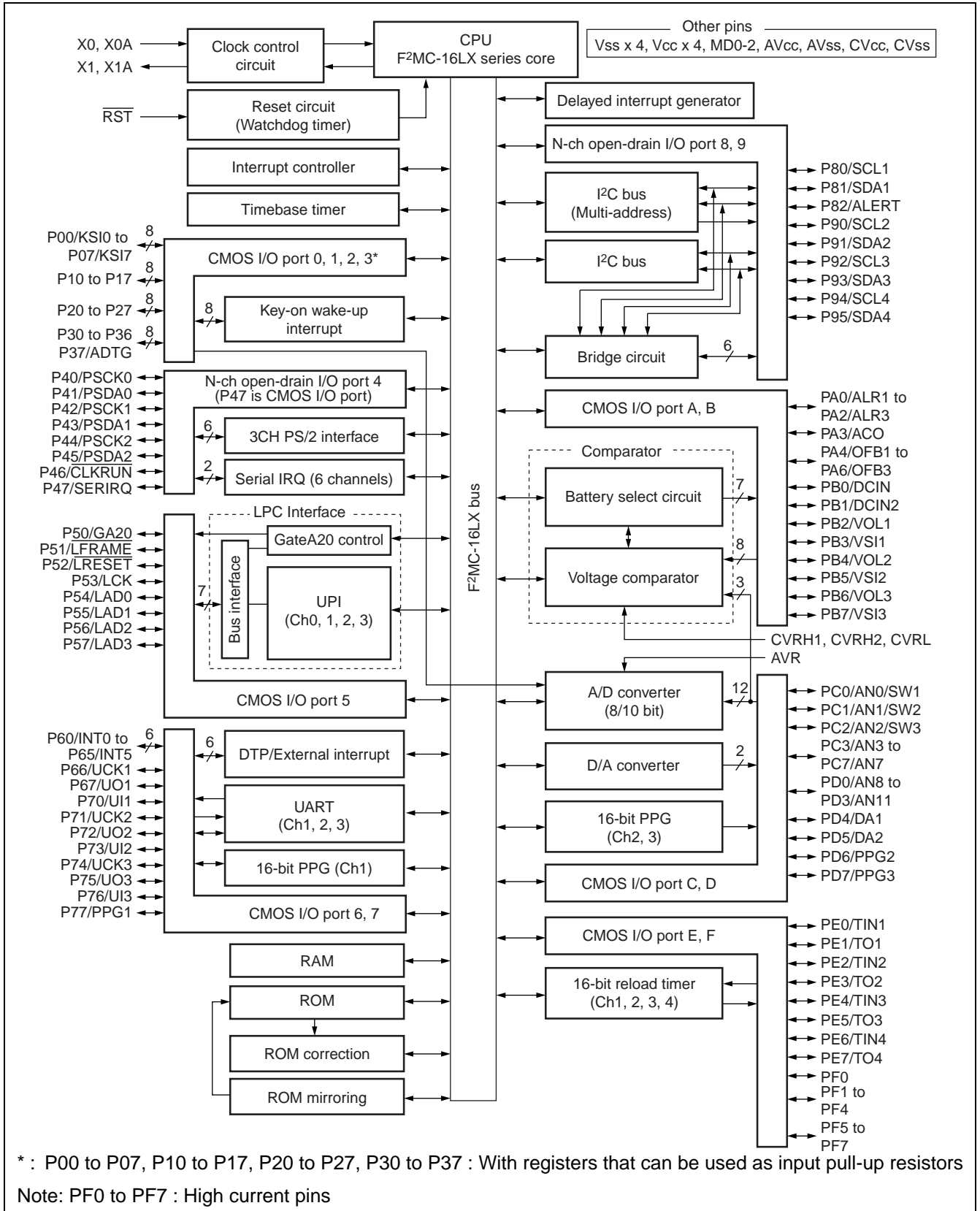

MB90370/375 Series

• MB90F377

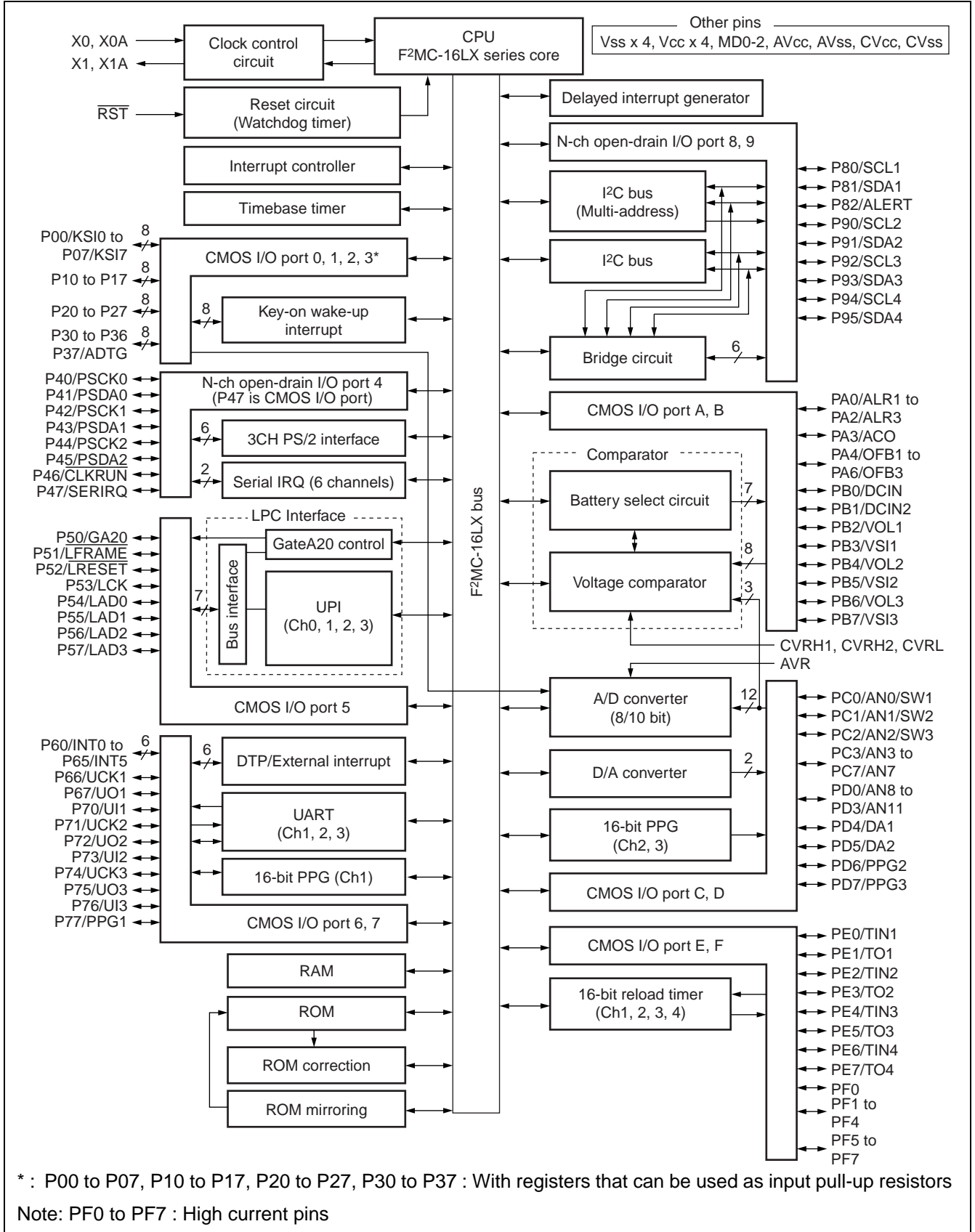

* : P00 to P07, P10 to P17, P20 to P27, P30 to P37 : With registers that can be used as input pull-up resistors

Note: PF0 to PF7 : High current pins

MB90370/375 Series

MEMORY MAP

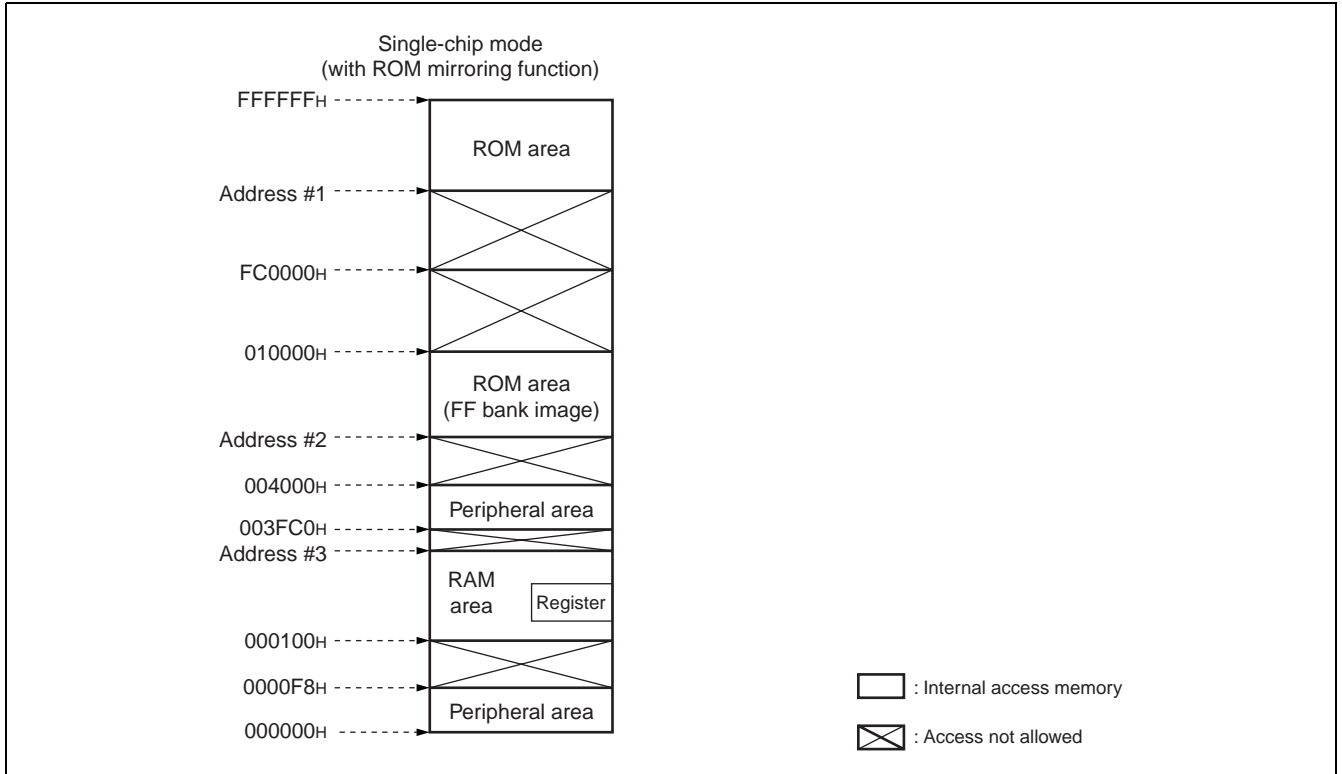

Model	Address #1	Address #2	Address #3
MB90372	FF0000 _H	004000 _H	001900 _H
MB90F372/F377	FF0000 _H	004000 _H	001900 _H
MB90V370	FF0000 _H *	004000 _H *	003FC0 _H

* : The MB90V370 does not contain ROM. Assume that the development tool uses these area for its ROM decode areas.

Note : ROM data in the FF bank can be seen as an image in the higher 00 bank to validate the small model C compiler. Because addresses of the 16 low-order bits in the FF bank are the same, the table in ROM can be referenced without the "far" specification. For example, when 00C000_H is accessed, the contents of ROM at FFC000_H are actually accessed. The ROM area in the FF bank exceeds 48 kilobytes, and all areas cannot be seen as images in the 00 bank. Because ROM data from FF4000_H to FFFFFFF_H is seen as an image at 004000_H to 00FFFF_H, the ROM data table should be stored in the area from FF4000_H to FFFFFFF_H.

MB90370/375 Series

■ F²MC-16LX CPU PROGRAMMING MODEL

- Dedicated registers

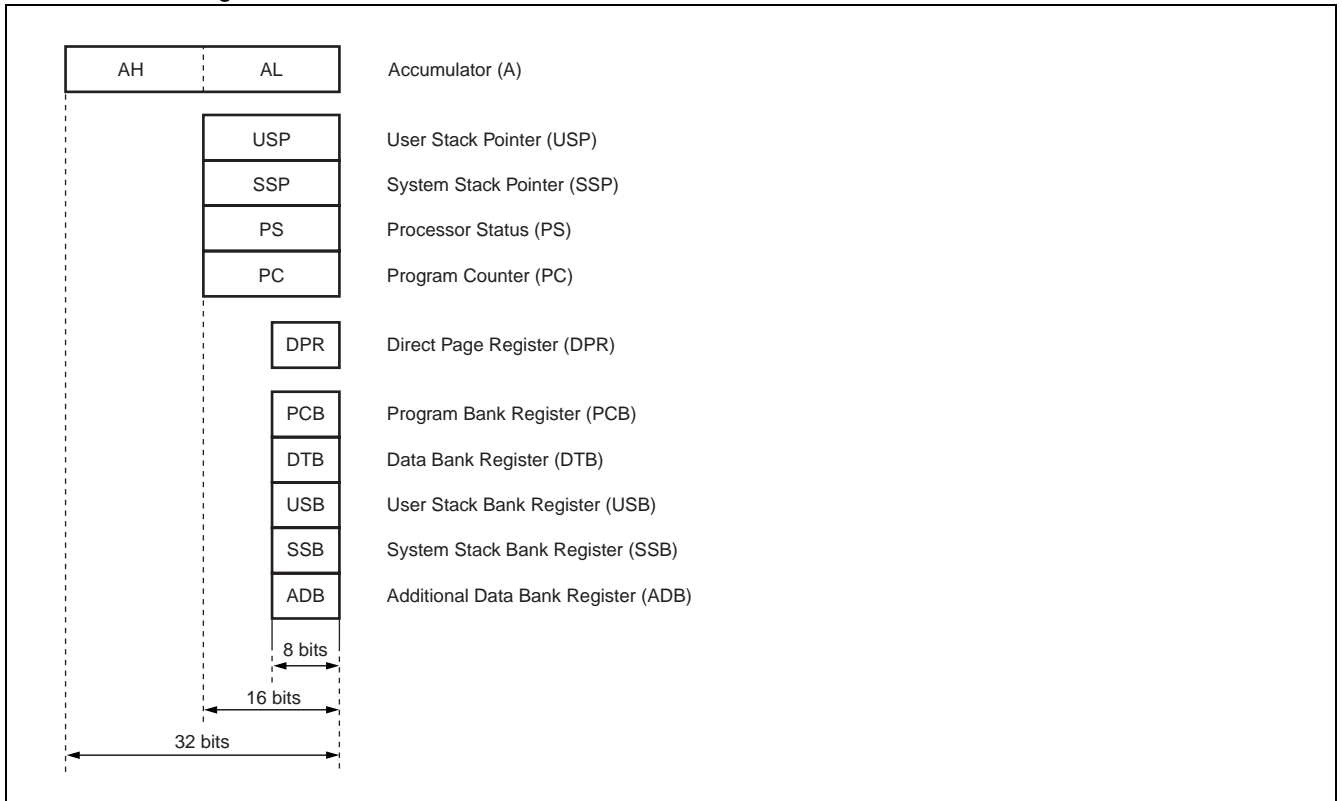

MB90370/375 Series

- General-purpose registers

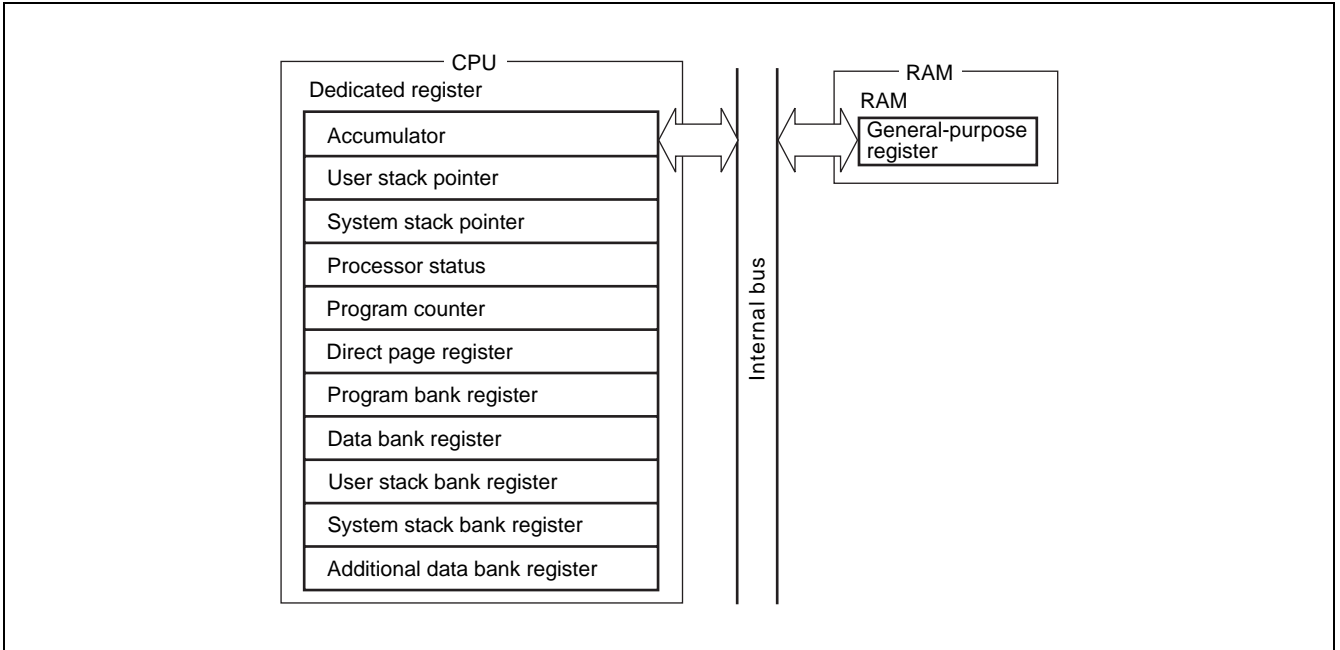

- Processor status (PS)

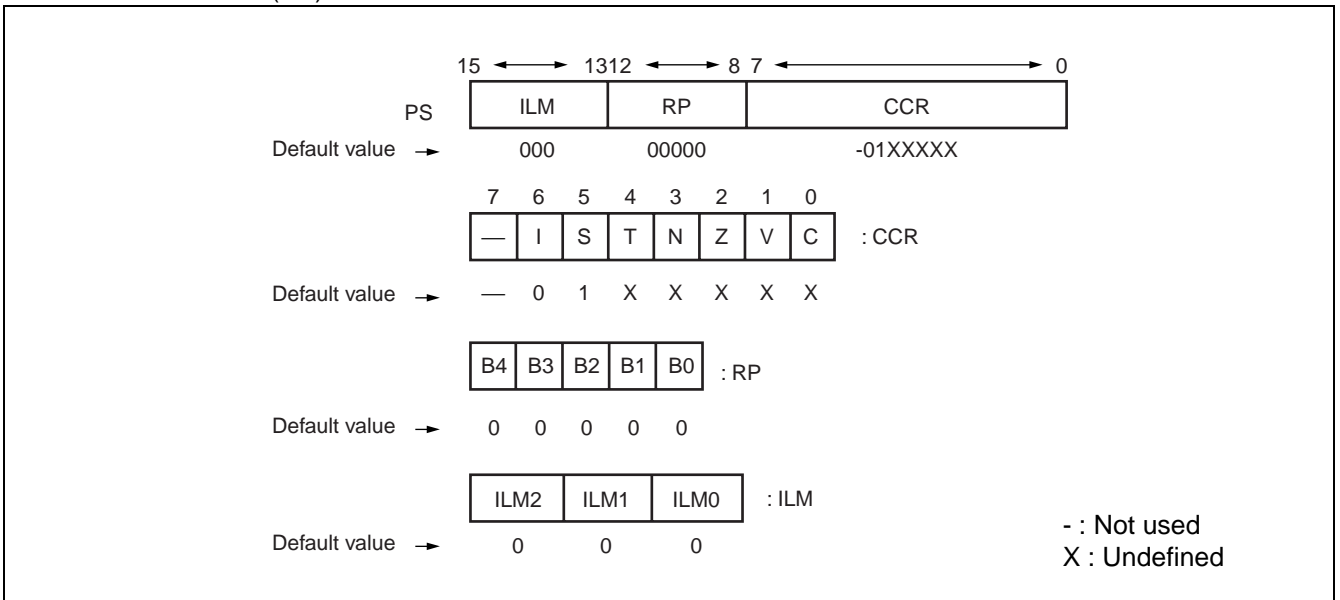

MB90370/375 Series

■ I/O MAP

Address	Abbreviation	Register	Byte access	Word access	Resource name	Initial value
000000 _H	PDR0	Port 0 data register	R/W	R/W	Port 0	XXXXXXXX _B
000001 _H	PDR1	Port 1 data register	R/W	R/W	Port 1	XXXXXXXX _B
000002 _H	PDR2	Port 2 data register	R/W	R/W	Port 2	XXXXXXXX _B
000003 _H	PDR3	Port 3 data register	R/W	R/W	Port 3	XXXXXXXX _B
000004 _H	PDR4	Port 4 data register	R/W	R/W	Port 4	X1111111 _B
000005 _H	PDR5	Port 5 data register	R/W	R/W	Port 5	XXXXXXXX _B
000006 _H	PDR6	Port 6 data register	R/W	R/W	Port 6	XXXXXXXX _B
000007 _H	PDR7	Port 7 data register	R/W	R/W	Port 7	XXXXXXXX _B
000008 _H	PDR8	Port 8 data register	R/W	R/W	Port 8	----111 _B
000009 _H	PDR9	Port 9 data register	R/W	R/W	Port 9	--111111 _B
00000A _H	PDRA	Port A data register	R/W	R/W	Port A	-XXXXXXXX _B
00000B _H	PDRB	Port B data register	R/W	R/W	Port B	XXXXXXXX _B
00000C _H	PDRC	Port C data register	R/W	R/W	Port C	XXXXXXXX _B
00000D _H	PDRD	Port D data register	R/W	R/W	Port D	XXXXXXXX _B
00000E _H	PDRE	Port E data register	R/W	R/W	Port E	XXXXXXXX _B
00000F _H	PDRF	Port F data register	R/W	R/W	Port F	XXXXXXXX _B
000010 _H	DDR0	Port 0 direction register	R/W	R/W	Port 0	00000000 _B
000011 _H	DDR1	Port 1 direction register	R/W	R/W	Port 1	00000000 _B
000012 _H	DDR2	Port 2 direction register	R/W	R/W	Port 2	00000000 _B
000013 _H	DDR3	Port 3 direction register	R/W	R/W	Port 3	00000000 _B
000014 _H	DDR4	Port 4 direction register	R/W	R/W	Port 4	0----- _B
000015 _H	DDR5	Port 5 direction register	R/W	R/W	Port 5	00000000 _B
000016 _H	DDR6	Port 6 direction register	R/W	R/W	Port 6	00000000 _B
000017 _H	DDR7	Port 7 direction register	R/W	R/W	Port 7	00000000 _B
000018 _H	PGDR	Parity generator data register	R/W	R/W	Parity generator	XXXXXXXX _B
000019 _H	PGCSR	Parity generator control status register	R/W	R/W		X-----0 _B
00001A _H	DDRA	Port A direction register	R/W	R/W	Port A	-0000000 _B
00001B _H	DDRB	Port B direction register	R/W	R/W	Port B	00000000 _B
00001C _H	DDRC	Port C direction register	R/W	R/W	Port C	00000000 _B
00001D _H	DDRD	Port D direction register	R/W	R/W	Port D	00000000 _B
00001E _H	DDRE	Port E direction register	R/W	R/W	Port E	00000000 _B
00001F _H	DDRF	Port F direction register	R/W	R/W	Port F	00000000 _B

(Continued)

MB90370/375 Series

Address	Abbreviation	Register	Byte access	Word access	Resource name	Initial value
000020 _H	SMR1	Serial mode register 1	R/W	R/W	UART1	00000-00 _B
000021 _H	SCR1	Serial control register 1	R/W	R/W		00000100 _B
000022 _H	SIDR1/ SODR1	Input data register 1 / Output data register 1	R/W	R/W		XXXXXXXX _B
000023 _H	SSR1	Serial status register 1	R/W	R/W		00001000 _B
000024 _H	M2CR1	Mode 2 control register 1	R/W	R/W		----1000 _B
000025 _H	CDCR1	Clock division control register 1	R/W	R/W	Communication prescaler 1	0---0000 _B
000026 _H	ENIR	Interrupt / DTP enable register	R/W	R/W	DTP/external interrupt	--000000 _B
000027 _H	EIRR	Interrupt / DTP cause register	R/W	R/W		--XXXXXX _B
000028 _H	ELVR	Request level setting register	R/W	R/W		00000000 _B
000029 _H			R/W	R/W		----0000 _B
00002A _H	ADER1	Analog input enable register 1	R/W	R/W	Port C, A/D	11111111 _B
00002B _H	ADER2	Analog input enable register 2	R/W	R/W	Port D, A/D	----1111 _B
00002C _H	BRSR	Bridge circuit selection register	R/W	R/W	Bridge circuit	--000000 _B
00002D _H	ADC0	A/D control register	R/W	R/W	8/10-bit A/D converter	00000000 _B
00002E _H	ADCR0	A/D data register	R	R		XXXXXXXX _B
00002F _H	ADCR1		R/W	R/W		00000-XX _B
000030 _H	ADCS0	A/D control status register	R/W	R/W		00----- _B
000031 _H	ADCS1		R/W	R/W		00000000 _B
000032 _H	SICRL	Serial interrupt request register	R/W	R/W	Serial IRQ	00000000 _B
000033 _H	SICRH	Serial interrupt control register	R/W	R/W		00000000 _B
000034 _H	SIFR1	Serial interrupt frame number register 1	R/W	R/W		--000000 _B
000035 _H	SIFR2	Serial interrupt frame number register 2	R/W	R/W		--000000 _B
000036 _H	SIFR3	Serial interrupt frame number register 3	R/W	R/W		--000000 _B
000037 _H	SIFR4	Serial interrupt frame number register 4	R/W	R/W		--000000 _B

(Continued)

MB90370/375 Series

Address	Abbreviation	Register	Byte access	Word access	Resource name	Initial value
000038 _H	PDCRL1	PPG1 down counter register	—	R	16-bit PPG timer (CH1)	11111111 _B
000039 _H	PDCRH1		—	R		11111111 _B
00003A _H	PCSRL1	PPG1 period setting register	—	W		XXXXXXXX _B
00003B _H	PCSRH1		—	W		XXXXXXXX _B
00003C _H	PDUTL1	PPG1 duty setting register	—	W		XXXXXXXX _B
00003D _H	PDUTH1		—	W		XXXXXXXX _B
00003E _H	PCNTL1	PPG1 control status register	R/W	R/W		--000000 _B
00003F _H	PCNTH1		R/W	R/W	00000000 _B	
000040 _H	PDCRL2	PPG2 down counter register	—	R	16-bit PPG timer (CH2)	11111111 _B
000041 _H	PDCRH2		—	R		11111111 _B
000042 _H	PCSRL2	PPG2 period setting register	—	W		XXXXXXXX _B
000043 _H	PCSRH2		—	W		XXXXXXXX _B
000044 _H	PDUTL2	PPG2 duty setting register	—	W		XXXXXXXX _B
000045 _H	PDUTH2		—	W		XXXXXXXX _B
000046 _H	PCNTL2	PPG2 control status register	R/W	R/W		--000000 _B
000047 _H	PCNTH2		R/W	R/W	00000000 _B	
000048 _H	PDCRL3	PPG3 down counter register	—	R	16-bit PPG timer (CH3)	11111111 _B
000049 _H	PDCRH3		—	R		11111111 _B
00004A _H	PCSRL3	PPG3 period setting register	—	W		XXXXXXXX _B
00004B _H	PCSRH3		—	W		XXXXXXXX _B
00004C _H	PDUTL3	PPG3 duty setting register	—	W		XXXXXXXX _B
00004D _H	PDUTH3		—	W		XXXXXXXX _B
00004E _H	PCNTL3	PPG3 control status register	R/W	R/W		--000000 _B
00004F _H	PCNTH3		R/W	R/W	00000000 _B	
000050 _H	PSCR0	PS/2 interface control register 0	R/W	R/W	3-channel PS/2 interface	0--00000 _B
000051 _H	PSSR0	PS/2 interface status register 0	R/W	R/W		00000000 _B
000052 _H	PSCR1	PS/2 interface control register 1	R/W	R/W		0--00000 _B
000053 _H	PSSR1	PS/2 interface status register 1	R/W	R/W		00000000 _B
000054 _H	PSCR2	PS/2 interface control register 2	R/W	R/W		0--00000 _B
000055 _H	PSSR2	PS/2 interface status register 2	R/W	R/W		00000000 _B
000056 _H	PSDR0	PS/2 interface data register 0	R/W	R/W		00000000 _B
000057 _H	PSDR1	PS/2 interface data register 1	R/W	R/W		00000000 _B
000058 _H	PSDR2	PS/2 interface data register 2	R/W	R/W		00000000 _B
000059 _H	PSMR	PS/2 interface mode register	R/W	R/W	----0000 _B	

(Continued)

MB90370/375 Series

Address	Abbreviation	Register	Byte access	Word access	Resource name	Initial value	
00005A _H	DAT0	D/A converter data register 0	R/W	R/W	D/A converter	XXXXXXXX _B	
00005B _H	DAT1	D/A converter data register 1	R/W	R/W		XXXXXXXX _B	
00005C _H	DACR0	D/A control register 0	R/W	R/W		-----0 _B	
00005D _H	DACR1	D/A control register 1	R/W	R/W		-----0 _B	
00005E _H	UPAL1	UPI1 address register (lower)	R/W	R/W	LPC interface	XXXXXXXX _B	
00005F _H	UPAH1	UPI1 address register (upper)	R/W	R/W		XXXXXXXX _B	
000060 _H	UPAL2	UPI2 address register (lower)	R/W	R/W		XXXXXXXX _B	
000061 _H	UPAH2	UPI2 address register (upper)	R/W	R/W		XXXXXXXX _B	
000062 _H	UPAL3	UPI3 address register (lower)	R/W	R/W		XXXXXXXX _B	
000063 _H	UPAH3	UPI3 address register (upper)	R/W	R/W		XXXXXXXX _B	
000064 _H	UPCL	UPI control register (lower)	R/W	R/W		0000000 _B	
000065 _H	UPCH	UPI control register (upper)	R/W	R/W		-000-000 _B	
000066 _H	UPDI0/ UPDO0	UPI0 data input register / data output register	R/W	R/W		XXXXXXXX _B	
000067 _H	UPS0	UPI0 status register	R/W	R/W		0000000 _B	
000068 _H	UPDI1/ UPDO1	UPI1 data input register / data output register	R/W	R/W		XXXXXXXX _B	
000069 _H	UPS1	UPI1 status register	R/W	R/W		0000000 _B	
00006A _H	UPDI2/ UPDO2	UPI2 data input register / data output register	R/W	R/W		XXXXXXXX _B	
00006B _H	UPS2	UPI2 status register	R/W	R/W		0000000 _B	
00006C _H	UPDI3/ UPDO3	UPI3 data input register / data output register	R/W	R/W		XXXXXXXX _B	
00006D _H	UPS3	UPI3 status register	R/W	R/W		0000000 _B	
00006E _H	LCR	LPC control register	R/W	R/W		----000 _B	
00006F _H	ROMM	ROM mirroring function selection register	W	W		ROM mirroring function	-----01 _B
000070 _H	TMCSRL1	Timer control status register CH1 (lower)	R/W	R/W		16-bit reload timer (CH1)	0000000 _B
000071 _H	TMCSRH1	Timer control status register CH1 (upper)	R/W	R/W			----0000 _B
000072 _H	TMR1/ TMRD1	16-bit timer/reload register CH1	—	R/W	XXXXXXXX _B		
000073 _H			—	R/W	XXXXXXXX _B		

(Continued)

MB90370/375 Series

Address	Abbreviation	Register	Byte access	Word access	Resource name	Initial value	
000074 _H	TMCSRL2	Timer control status register CH2 (lower)	R/W	R/W	16-bit reload timer (CH2)	00000000 _B	
000075 _H	TMCSRH2	Timer control status register CH2 (upper)	R/W	R/W		----0000 _B	
000076 _H	TMR2/ TMRD2	16-bit timer/reload register CH2	—	R/W		XXXXXXXX _B	
000077 _H			—	R/W		XXXXXXXX _B	
000078 _H	TMCSRL3	Timer control status register CH3 (lower)	R/W	R/W	16-bit reload timer (CH3)	00000000 _B	
000079 _H	TMCSRH3	Timer control status register CH3 (upper)	R/W	R/W		----0000 _B	
00007A _H	TMR3/ TMRD3	16-bit timer/reload register CH3	—	R/W		XXXXXXXX _B	
00007B _H			—	R/W		XXXXXXXX _B	
00007C _H	TMCSRL4	Timer control status register CH4 (lower)	R/W	R/W	16-bit reload timer (CH4)	00000000 _B	
00007D _H	TMCSRH4	Timer control status register CH4 (upper)	R/W	R/W		----0000 _B	
00007E _H	TMR4/ TMRD4	16-bit timer/reload register CH4	—	R/W		XXXXXXXX _B	
00007F _H			—	R/W		XXXXXXXX _B	
000080 _H	IBCRL	I ² C bus control register (lower)	R/W	R/W	I ² C	----0000 _B	
000081 _H	IBCRH	I ² C bus control register (upper)	R/W	R/W		00000000 _B	
000082 _H	IBSRL	I ² C bus status register (lower)	R	R		00000000 _B	
000083 _H	IBSRH	I ² C bus status register (upper)	R/W	R/W		--000000 _B	
000084 _H	IDAR	I ² C data register	R/W	R/W		XXXXXXXX _B	
000085 _H	IADR	I ² C address register	R/W	R/W		-XXXXXXXX _B	
000086 _H	ICCR	I ² C clock control register	R/W	R/W		0-000000 _B	
000087 _H	ITCR	I ² C timeout control register	R/W	R/W		-0-00000 _B	
000088 _H	ITOC	I ² C timeout clock register	R/W	R/W		00000000 _B	
000089 _H	ITOD	I ² C timeout data register	R/W	R/W		00000000 _B	
00008A _H	ISTO	I ² C slave timeout register	R/W	R/W		00000000 _B	
00008B _H	IMTO	I ² C master timeout register	R/W	R/W		00000000 _B	
00008C _H	RDR0	Port 0 pull-up resistor setting register	R/W	R/W		Port 0	00000000 _B
00008D _H	RDR1	Port 1 pull-up resistor setting register	R/W	R/W		Port 1	00000000 _B
00008E _H	RDR2	Port 2 pull-up resistor setting register	R/W	R/W	Port 2	00000000 _B	
00008F _H	RDR3	Port 3 pull-up resistor setting register	R/W	R/W	Port 3	00000000 _B	

(Continued)

MB90370/375 Series

Address	Abbrevia- tion	Register	Byte access	Word access	Resource name	Initial value
000090 _H to 9D _H	Prohibited area					
00009E _H	PACSR	Program address detect control status register	R/W	R/W	ROM correction	----0000 _B
00009F _H	DIRR	Delayed interrupt cause / clear register	R/W	R/W	Delayed interrupt	-----0 _B
0000A0 _H	LPMCR	Low-power consumption mode register	R/W	R/W	Low-power consumption control register	00011000 _B
0000A1 _H	CKSCR	Clock selection register	R/W	R/W		11111100 _B
0000A2 _H to A7 _H	Prohibited area					
0000A8 _H	WDTC	Watchdog control register	R/W	R/W	Watchdog timer	X-XXX111 _B
0000A9 _H	TBTC	Timebase timer control register	R/W	R/W	Timebase timer	1--00100 _B
0000AA _H	WTC	Watch timer control register	R/W	R/W	Watch timer	10001000 _B
0000AB _H	Prohibited area					
0000AC _H	EICR	Wake-up interrupt control register	R/W	R/W	Wake-up interrupt	00000000 _B
0000AD _H	EIFR	Wake-up interrupt flag register	R/W	R/W		-----0 _B
0000AE _H	FMCS	Flash memory control status register	R/W	R/W	Flash memory interface circuit	00010000 _B
0000AF _H	Prohibited area					
0000B0 _H	ICR00	Interrupt control register 00	R/W	R/W	Interrupt controller	00000111 _B
0000B1 _H	ICR01	Interrupt control register 01	R/W	R/W		00000111 _B
0000B2 _H	ICR02	Interrupt control register 02	R/W	R/W		00000111 _B
0000B3 _H	ICR03	Interrupt control register 03	R/W	R/W		00000111 _B
0000B4 _H	ICR04	Interrupt control register 04	R/W	R/W		00000111 _B
0000B5 _H	ICR05	Interrupt control register 05	R/W	R/W		00000111 _B
0000B6 _H	ICR06	Interrupt control register 06	R/W	R/W		00000111 _B
0000B7 _H	ICR07	Interrupt control register 07	R/W	R/W		00000111 _B
0000B8 _H	ICR08	Interrupt control register 08	R/W	R/W		00000111 _B
0000B9 _H	ICR09	Interrupt control register 09	R/W	R/W		00000111 _B
0000BA _H	ICR10	Interrupt control register 10	R/W	R/W		00000111 _B

(Continued)

MB90370/375 Series

Address	Abbreviation	Register	Byte access	Word access	Resource name	Initial value	
0000BB _H	ICR11	Interrupt control register 11	R/W	R/W	Interrupt controller	0000111 _B	
0000BC _H	ICR12	Interrupt control register 12	R/W	R/W		0000111 _B	
0000BD _H	ICR13	Interrupt control register 13	R/W	R/W		0000111 _B	
0000BE _H	ICR14	Interrupt control register 14	R/W	R/W		0000111 _B	
0000BF _H	ICR15	Interrupt control register 15	R/W	R/W		0000111 _B	
0000C0 _H	MBCRL	MI ² C bus control register (lower)	R/W	R/W	MI ² C	---0000 _B	
0000C1 _H	MBCRH	MI ² C bus control register (upper)	R/W	R/W		0000000 _B	
0000C2 _H	MBSRL	MI ² C bus status register (lower)	R	R		0000000 _B	
0000C3 _H	MBSRH	MI ² C bus status register (upper)	R/W	R/W		--00000 _B	
0000C4 _H	MDAR	MI ² C data register	R/W	R/W		XXXXXXXX _B	
0000C5 _H	MALR	MI ² C alert register	R/W	R/W		---0000 _B	
0000C6 _H	MADR1	MI ² C address register 1	R/W	R/W		-XXXXXXXX _B	
0000C7 _H	MADR2	MI ² C address register 2	R/W	R/W		-XXXXXXXX _B	
0000C8 _H	MADR3	MI ² C address register 3	R/W	R/W		-XXXXXXXX _B	
0000C9 _H	MADR4	MI ² C address register 4	R/W	R/W		-XXXXXXXX _B	
0000CA _H	MADR5	MI ² C address register 5	R/W	R/W		-XXXXXXXX _B	
0000CB _H	MADR6	MI ² C address register 6	R/W	R/W		-XXXXXXXX _B	
0000CC _H	MCCR	MI ² C clock control register	R/W	R/W		0-00000 _B	
0000CD _H	MTCR	MI ² C timeout control register	R/W	R/W		-0-0000 _B	
0000CE _H	MTOC	MI ² C timeout clock register	R/W	R/W		0000000 _B	
0000CF _H	MTOD	MI ² C timeout data register	R/W	R/W		0000000 _B	
0000D0 _H	MSTO	MI ² C slave timeout register	R/W	R/W		0000000 _B	
0000D1 _H	MMTO	MI ² C master timeout register	R/W	R/W		0000000 _B	
0000D2 _H	SMR2	Serial mode register 2	R/W	R/W		UART2	0000-00 _B
0000D3 _H	SCR2	Serial control register 2	R/W	R/W			0000100 _B
0000D4 _H	SIDR2/ SODR2	Input data register 2 / output data register 2	R/W	R/W	XXXXXXXX _B		
0000D5 _H	SSR2	Status register 2	R/W	R/W	00001000 _B		
0000D6 _H	M2CR2	Mode 2 control register 2	R/W	R/W	---1000 _B		
0000D7 _H	CDCR2	Clock division control register 2	R/W	R/W	Communication prescaler 2	0---0000 _B	

(Continued)

MB90370/375 Series

Address	Abbreviation	Register	Byte access	Word access	Resource name	Initial value
0000D8 _H	COCRL	Comparator control register (lower)	R/W	R/W	Voltage comparator	--000000 _B
0000D9 _H	COCRH	Comparator control register (upper)	R/W	R/W		00011111 _B
0000DA _H	COSRL1	Comparator status register 1 (lower)	R/W	R/W		00000000 _B
0000DB _H	COSRH1	Comparator status register 1 (upper)	R/W	R/W		--000000 _B
0000DC _H	CICRL	Comparator interrupt control register (lower)	R/W	R/W		00000000 _B
0000DD _H	CICRH	Comparator interrupt control register (upper)	R/W	R/W		--000000 _B
0000DE _H	COSRL2	Comparator status register 2 (lower)	R	R		XXXXXXXX _B
0000DF _H	COSRH2	Comparator status register 2 (upper)	R	R		--XXXXXXXX _B
0000E0 _H	CIER	Comparator input enable register	R/W	R/W		---11111 _B
0000E1 _H	BDR	Bit data register	R/W	R/W		Bit decoder
0000E2 _H	BRRL	Bit result register (lower)	R	R	XXXXXXXX _B	
0000E3 _H	BRRH	Bit result register (upper)	R	R	XXXXXXXX _B	
0000E4 _H	SMR3	Serial mode register 3	R/W	R/W	UART3	00000-00 _B
0000E5 _H	SCR3	Serial control register 3	R/W	R/W		00000100 _B
0000E6 _H	SIDR3/ SODR3	Input data register 3 / output data register 3	R/W	R/W		XXXXXXXX _B
0000E7 _H	SSR3	Status register 3	R/W	R/W		00001000 _B
0000E8 _H	M2CR3	Mode 2 control register 3	R/W	R/W		----1000 _B
0000E9 _H	CDCR3	Clock division control register 3	R/W	R/W		Communication prescaler 3
0000EA _H	PDL3	Port 3 data latch register	R/W	R/W	Port 3 data latch	00000000 _B
0000EB _H to ED _H	Prohibited area					
0000EE _H	LCRL* ¹	LCD control register 0* ²	R/W	R/W	LCD controller / driver	00010000 _B
0000EF _H	LCRH* ¹	LCD control register 1* ²	R/W	R/W		00000000 _B
0000F0 _H to F4 _H	VRAM* ¹	LCD display RAM* ²	R/W	—		XXXXXXXX _B
0000F5 _H to F7 _H	Prohibited area					
0000F8 _H to FF _H	External area					

(Continued)

MB90370/375 Series

Address	Abbreviation	Register	Byte access	Word access	Resource name	Initial value
001FF0H	PADR0	Program address detection register 0	R/W	R/W	ROM correction	XXXXXXXX _B
001FF1H		Program address detection register 1	R/W	R/W		XXXXXXXX _B
001FF2H		Program address detection register 2	R/W	R/W		XXXXXXXX _B
001FF3H	PADR1	Program address detection register 3	R/W	R/W		XXXXXXXX _B
001FF4H		Program address detection register 4	R/W	R/W		XXXXXXXX _B
001FF5H		Program address detection register 5	R/W	R/W		XXXXXXXX _B
003FC0H	UDRL0	UP data register 0 (lower)	R/W	R/W	LPC data buffer array	XXXXXXXX _B
003FC1H	UDRH0	UP data register 0 (upper)	R/W	R/W		XXXXXXXX _B
003FC2H	UDRL1	UP data register 1 (lower)	R/W	R/W		XXXXXXXX _B
003FC3H	UDRH1	UP data register 1 (upper)	R/W	R/W		XXXXXXXX _B
003FC4H	UDRL2	UP data register 2 (lower)	R/W	R/W		XXXXXXXX _B
003FC5H	UDRH2	UP data register 2 (upper)	R/W	R/W		XXXXXXXX _B
003FC6H	UDRL3	UP data register 3 (lower)	R/W	R/W		XXXXXXXX _B
003FC7H	UDRH3	UP data register 3 (upper)	R/W	R/W		XXXXXXXX _B
003FC8H	UDRL4	UP data register 4 (lower)	R/W	R/W		XXXXXXXX _B
003FC9H	UDRH4	UP data register 4 (upper)	R/W	R/W		XXXXXXXX _B
003FCAH	UDRL5	UP data register 5 (lower)	R/W	R/W		XXXXXXXX _B
003FCBH	UDRH5	UP data register 5 (upper)	R/W	R/W		XXXXXXXX _B
003FCC _H	UDRL6	UP data register 6 (lower)	R/W	R/W		XXXXXXXX _B
003FCD _H	UDRH6	UP data register 6 (upper)	R/W	R/W		XXXXXXXX _B
003FCE _H	UDRL7	UP data register 7 (lower)	R/W	R/W		XXXXXXXX _B
003FCF _H	UDRH7	UP data register 7 (upper)	R/W	R/W		XXXXXXXX _B
003FD0 _H	UDRL8	UP data register 8 (lower)	R/W	R/W		XXXXXXXX _B
003FD1 _H	UDRH8	UP data register 8 (upper)	R/W	R/W		XXXXXXXX _B
003FD2 _H	UDRL9	UP data register 9 (lower)	R/W	R/W		XXXXXXXX _B
003FD3 _H	UDRH9	UP data register 9 (upper)	R/W	R/W	XXXXXXXX _B	

(Continued)

MB90370/375 Series

(Continued)

Address	Abbreviation	Register	Byte access	Word access	Resource name	Initial value	
003FD4 _H	UDRLA	UP data register A (lower)	R/W	R/W	LPC data buffer array	XXXXXXXX _B	
003FD5 _H	UDRHA	UP data register A (upper)	R/W	R/W		XXXXXXXX _B	
003FD6 _H	UDRLB	UP data register B (lower)	R/W	R/W		XXXXXXXX _B	
003FD7 _H	UDRHB	UP data register B (upper)	R/W	R/W		XXXXXXXX _B	
003FD8 _H	UDRLC	UP data register C (lower)	R/W	R/W		XXXXXXXX _B	
003FD9 _H	UDRHC	UP data register C (upper)	R/W	R/W		XXXXXXXX _B	
003FDA _H	UDRLD	UP data register D (lower)	R/W	R/W		XXXXXXXX _B	
003FDB _H	UDRHD	UP data register D (upper)	R/W	R/W		XXXXXXXX _B	
003FDC _H	UDRLE	UP data register E (lower)	R/W	R/W		XXXXXXXX _B	
003FDD _H	UDRHE	UP data register E (upper)	R/W	R/W		XXXXXXXX _B	
003FDE _H	UDRLF	UP data register F (lower)	R/W	R/W		XXXXXXXX _B	
003FDF _H	UDRHF	UP data register F (upper)	R/W	R/W		XXXXXXXX _B	
003FE0 _H	DNDL0	DOWN data register 0 (lower)	R	R		XXXXXXXX _B	
003FE1 _H	DNDH0	DOWN data register 0 (upper)	R	R		XXXXXXXX _B	
003FE2 _H	DNDL1	DOWN data register 1 (lower)	R	R		XXXXXXXX _B	
003FE3 _H	DNDH1	DOWN data register 1 (upper)	R	R		XXXXXXXX _B	
003FE4 _H	DNDL2	DOWN data register 2 (lower)	R	R		XXXXXXXX _B	
003FE5 _H	DNDH2	DOWN data register 2 (upper)	R	R		XXXXXXXX _B	
003FE6 _H	DNDL3	DOWN data register 3 (lower)	R	R		XXXXXXXX _B	
003FE7 _H	DNDH3	DOWN data register 3 (upper)	R	R		XXXXXXXX _B	
003FE8 _H	DNDL4	DOWN data register 4 (lower)	R	R		XXXXXXXX _B	
003FE9 _H	DNDH4	DOWN data register 4 (upper)	R	R		XXXXXXXX _B	
003FEA _H	DNDL5	DOWN data register 5 (lower)	R	R		XXXXXXXX _B	
003FEB _H	DNDH5	DOWN data register 5 (upper)	R	R		XXXXXXXX _B	
003FEC _H	DNDL6	DOWN data register 6 (lower)	R	R		XXXXXXXX _B	
003FED _H	DNDH6	DOWN data register 6 (upper)	R	R		XXXXXXXX _B	
003FEE _H	DNDL7	DOWN data register 7 (lower)	R	R		XXXXXXXX _B	
003FEF _H	DNDH7	DOWN data register 7 (upper)	R	R		XXXXXXXX _B	
003FF0 _H	DBAAL	Data buffer array address register (lower)	R/W	R/W		XXXXXXXX _B	
003FF1 _H	DBAAH	Data buffer array address register (upper)	R/W	R/W		XXXXXXXX _B	
003FF2 _H to 003FFF _H	Prohibited area						

MB90370/375 Series

- **Meaning of abbreviations used for reading and writing**

R/W : Read and write enabled

R : Read-only

W : Write-only

- **Explanation of initial values**

0 : The bit is initialized to 0.

1 : The bit is initialized to 1.

X : The initial value of the bit is undefined.

- : The bit is not used. Its initial value is undefined.

- **Instruction using IO addressing e.g. MOV A, io, is not supported for registers area 003FC0_H to 003FFF_H.**

*1 : It doesn't exist in MB90F377.

*2 : Prohibited area in MB90F377.

MB90370/375 Series

- : Can be used and interrupt request flag is cleared by EI²OS interrupt clear signal.
- × : Cannot be used.
- ◎ : Can be used and support the EI²OS stop request.
- △ : Can be used.

- *1 :
- For peripheral functions that share the ICR register, the interrupt level will be the same.
 - If the extended intelligent I/O service is to be used with a peripheral function that shares the ICR register with another peripheral function, the service can be started by either of the function. And if EI²OS clear is supported, both interrupt request flags for the two interrupt causes are cleared by EI²OS interrupt clear signal. It is recommended to mask either of the interrupt request during the use of EI²OS.
 - EI²OS service cannot be started multiple times simultaneously. Interrupt other than the operating interrupt is masked during EI²OS operation. It is recommended to mask either of the interrupt requests during the use of EI²OS.

- *2 : This priority is applied when interrupts of the same level occur simultaneously.

■ PERIPHERAL RESOURCES

1. Low-power Consumption Control Circuit

The MB90370/375 series has the following CPU operating mode selected by the configuration of an operating clock and clock operation control.

• Clock Mode

- PLL clock mode
In this mode, a PLL clock that is a multiple of the oscillation clock (HCLK) is used to operate the CPU and peripheral functions.
- Main clock mode
In this mode, the main clock, with the oscillation clock (HCLK) frequency divided by 2 is used to operate the CPU and peripheral functions. In the main clock mode, the PLL multiplier circuit is inactive.
- Sub-clock mode
In this mode, the sub-clock, with the sub-clock (SCLK) frequency divided by 4 is used to operate the CPU and peripheral functions. In the sub-clock mode, the main clock and PLL multiplier circuit are inactive.

• CPU Intermittent Operating Mode

In this mode, the CPU is operated intermittently while high-speed clock pulses are supplied to peripheral functions, thereby reducing power consumption. In this mode, intermittent clock pulses are supplied only to the CPU while it is accessing a register, internal memory, or peripheral function.

• Standby Mode

In this mode, the low-power consumption control circuit stops supplying the clock to the CPU (sleep mode) or the CPU and peripheral functions (timebase timer mode) or stops the oscillation clock itself (stop mode), thereby reducing power consumption.

- PLL sleep mode
The PLL sleep mode is activated to stop the CPU operating clock in the PLL clock mode. Components excluding the CPU operate on the PLL clock.
- Main sleep mode
The main sleep mode is activated to stop the CPU operating clock in the main clock mode. Components excluding the CPU operate on the main clock.
- Sub-sleep mode
The sub-sleep mode is activated to stop the CPU operating clock in the sub-clock mode. Components excluding the CPU operate on the divided-by-four sub-clock.
- Timebase timer mode
The timebase timer mode causes the operation of functions, excluding the oscillation clock, timebase timer, and watch timer, to stop. All functions other than the timebase timer and watch timer are inactivated.
- Watch mode and main watch mode
The watch mode and main watch mode operates the watch timer only. The sub-clock operates but the main clock and PLL multiplier circuit stop.
- Stop mode
The stop mode causes the oscillation to stop. All functions are inactivated.

Note : Because the stop mode turns the oscillation clock off, data can be retained by the lowest power consumption.

MB90370/375 Series

(1) Register configuration

Clock Selection Register									
Address : 0000A1 _H	15	14	13	12	11	10	9	8	Bit number CKSCR
	SCM	MCM	WS1	WS0	SCS	MCS	CS1	CS0	
Read/write	R	R	R/W	R/W	R/W	R/W	R/W	R/W	
Initial value	1	1	1	1	1	1	0	0	

Lower Power Consumption Mode Control Register									
Address : 0000A0 _H	7	6	5	4	3	2	1	0	Bit number LPMCR
	STP	SLP	SPL	RST	TMD	CG1	CG0	Reserved	
Read/write	W	W	R/W	W	W	R/W	R/W	R/W	
Initial value	0	0	0	1	1	0	0	0	

(2) Block diagram

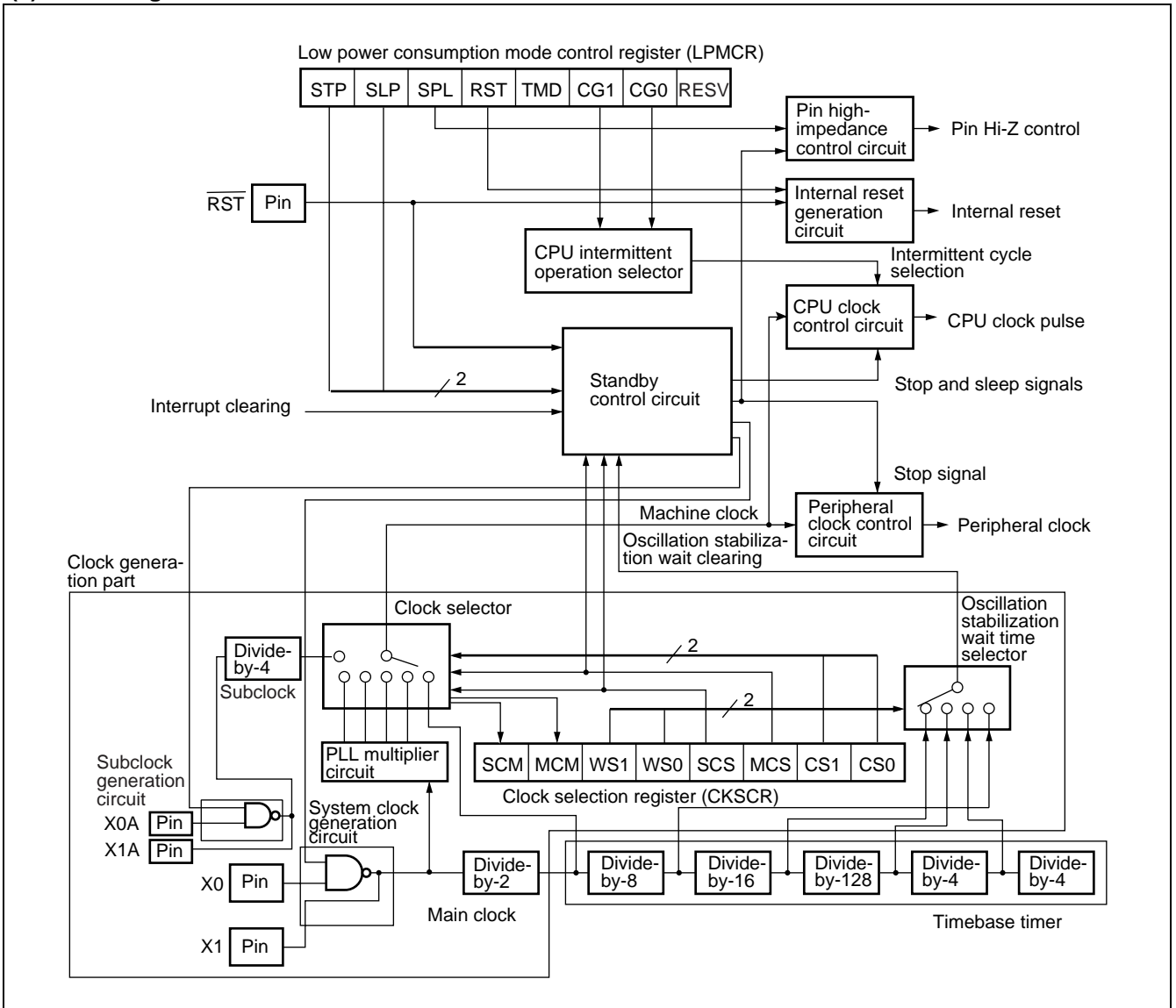

MB90370/375 Series

2. I/O Ports

(1) Outline of I/O ports

Each I/O port outputs data from the CPU to the I/O pins or inputs signals from the I/O pins to the CPU as directed by the port data register (PDR). Each CMOS I/O port can also designate the direction of a data flow (input or output) at the I/O pins in bit units using the port data direction register (DDR). Or N-channel open-drain port can designate the direction of a data flow (input or output) at the I/O pins in bit units using the port data register (PDR). The function of each port and the resources using it are described below:

- Port 0 : General-purpose I/O port/resource (Key-on wake-up interrupt)
- Port 1 : General-purpose I/O port
- Port 2 : General-purpose I/O port
- Port 3 : General-purpose I/O port/resource (A/D converter external trigger)
- Port 4 : General-purpose I/O port/resource (PS/2 interface / serial IRQ controller)
- Port 5 : General-purpose I/O port/resource (LPC interface)
- Port 6 : General-purpose I/O port/resource (DTP / UART1)
- Port 7 : General-purpose I/O port/resource (UART1 / UART2 / UART3 / PPG1)
- Port 8 : General-purpose I/O port/resource (Multi-address I²C)
- Port 9 : General-purpose I/O port/resource (I²C / Multi-address I²C)
- Port A : General-purpose I/O port/resource (Comparator)
- Port B : General-purpose I/O port/resource (Comparator)
- Port C : General-purpose I/O port/resource (Comparator / A/D converter)
- Port D : General-purpose I/O port/resource (A/D converter / D/A converter / PPG2 / PPG3)
- Port E : General-purpose I/O port/resource (Reload timer1 to 4 / LCD controller*)
- Port F : General-purpose I/O port/resource (LCD controller*)

* : LCD controller doesn't exist in MB90F377, and so Port E and F of MB90F377 are not used for this purpose.

(2) Register configuration

Register	Read/Write	Address	Initial value
Port 0 data register (PDR0)	R/W	000000H	XXXXXXXX _B
Port 1 data register (PDR1)	R/W	000001H	XXXXXXXX _B
Port 2 data register (PDR2)	R/W	000002H	XXXXXXXX _B
Port 3 data register (PDR3)	R/W	000003H	XXXXXXXX _B
Port 4 data register (PDR4)	R/W	000004H	X1111111 _B
Port 5 data register (PDR5)	R/W	000005H	XXXXXXXX _B
Port 6 data register (PDR6)	R/W	000006H	XXXXXXXX _B
Port 7 data register (PDR7)	R/W	000007H	XXXXXXXX _B
Port 8 data register (PDR8)	R/W	000008H	----111 _B
Port 9 data register (PDR9)	R/W	000009H	--111111 _B
Port A data register (PDRA)	R/W	00000AH	-XXXXXXXX _B
Port B data register (PDRB)	R/W	00000BH	XXXXXXXX _B
Port C data register (PDRC)	R/W	00000CH	XXXXXXXX _B
Port D data register (PDRD)	R/W	00000DH	XXXXXXXX _B
Port E data register (PDRE)	R/W	00000EH	XXXXXXXX _B

(Continued)

MB90370/375 Series

(Continued)

Register	Read/Write	Address	Initial value
Port F data register (PDRF)	R/W	00000FH	XXXXXXXX _B
Port 0 data direction register (DDR0)	R/W	000010H	00000000 _B
Port 1 data direction register (DDR1)	R/W	000011H	00000000 _B
Port 2 data direction register (DDR2)	R/W	000012H	00000000 _B
Port 3 data direction register (DDR3)	R/W	000013H	00000000 _B
Port 4 data direction register (DDR4)	R/W	000014H	0----- _B
Port 5 data direction register (DDR5)	R/W	000015H	00000000 _B
Port 6 data direction register (DDR6)	R/W	000016H	00000000 _B
Port 7 data direction register (DDR7)	R/W	000017H	00000000 _B
Port A data direction register (DDRA)	R/W	00001AH	-0000000 _B
Port B data direction register (DDRB)	R/W	00001BH	00000000 _B
Port C data direction register (DDRC)	R/W	00001CH	00000000 _B
Port D data direction register (DDRD)	R/W	00001DH	00000000 _B
Port E data direction register (DDRE)	R/W	00001EH	00000000 _B
Port F data direction register (DDRF)	R/W	00001FH	00000000 _B
Analog data input enable register (ADER1)	R/W	00002AH	11111111 _B
Analog data input enable register (ADER2)	R/W	00002BH	----1111 _B
Comparator input enable register (CIER)	R/W	0000E0H	---11111 _B
LCD control register 1 (LCRH)	R/W	0000EFH	00000000 _B
Port 0 pull-up resistor setting register (RDR0)	R/W	00008CH	00000000 _B
Port 1 pull-up resistor setting register (RDR1)	R/W	00008DH	00000000 _B
Port 2 pull-up resistor setting register (RDR2)	R/W	00008EH	00000000 _B
Port 3 pull-up resistor setting register (RDR3)	R/W	00008FH	00000000 _B
Port 3 data latch register (PDL3)	R/W	0000EAH	00000000 _B

R/W : Read/write enabled

X : Undefined

- : Not used

(3) Block diagram of I/O ports

- Block diagram of port 0 pins

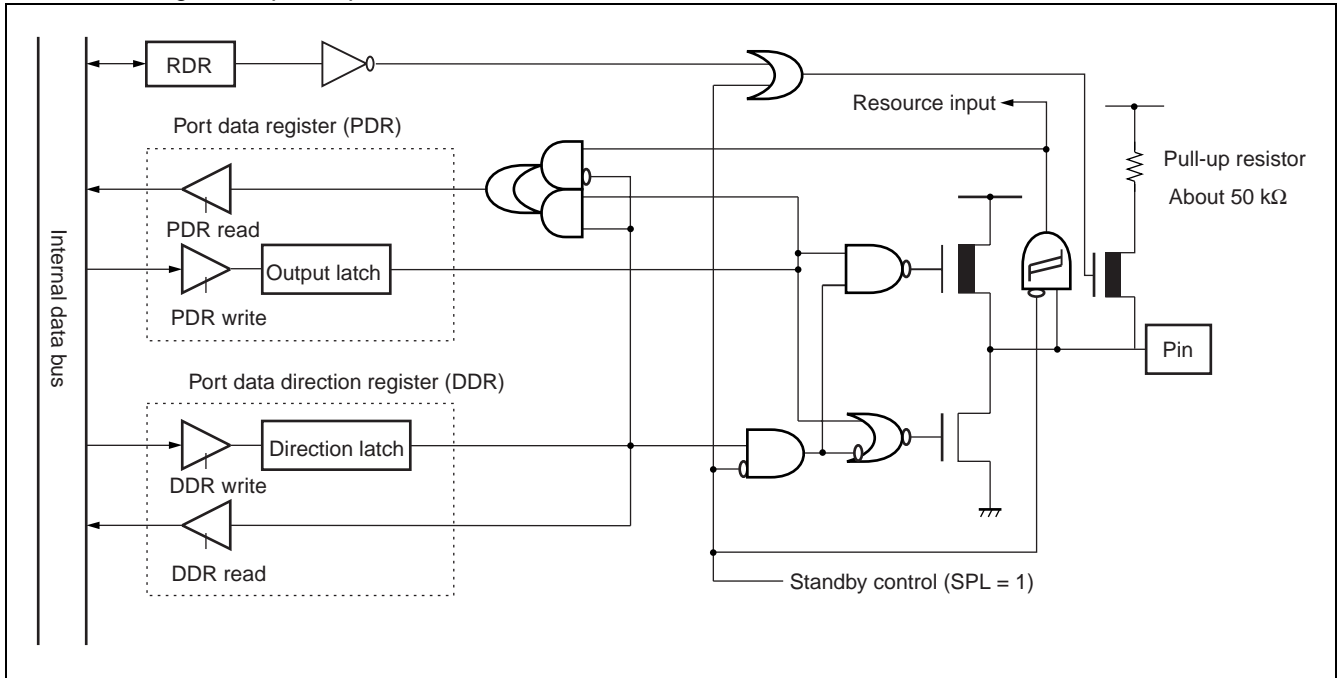

- Block diagram of port 1 pins

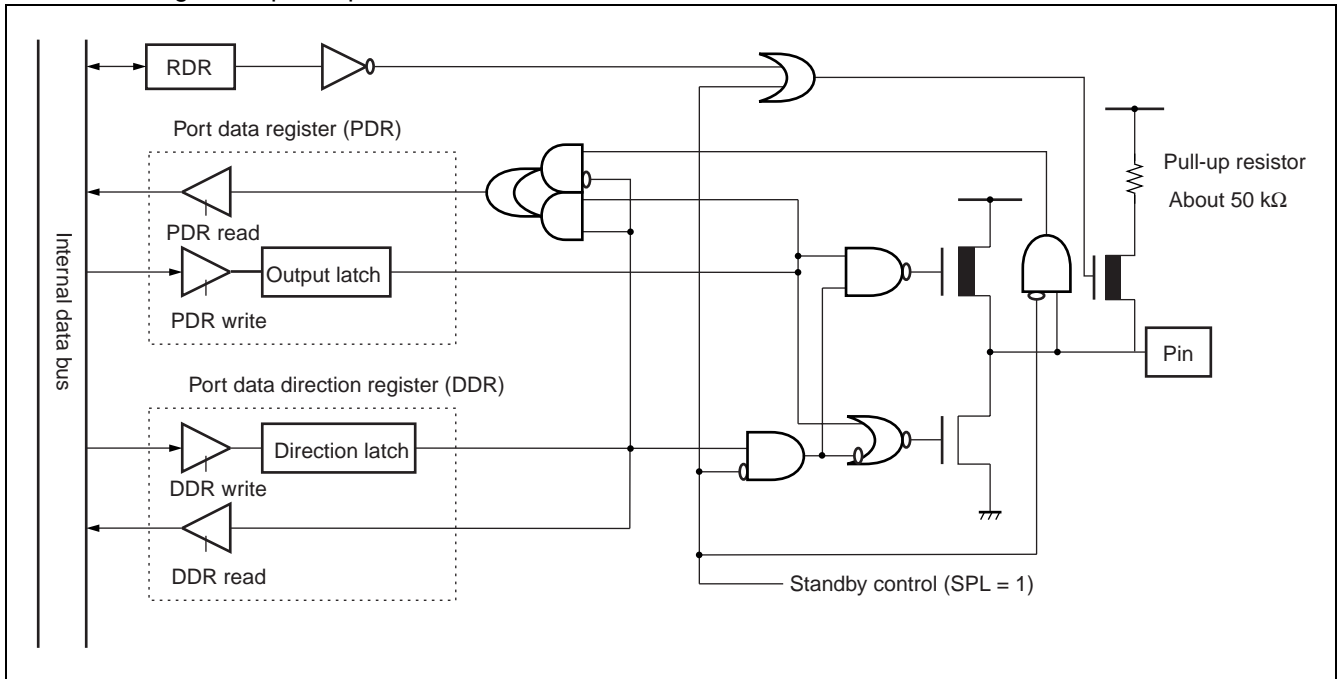

MB90370/375 Series

- Block diagram of port 2 pins

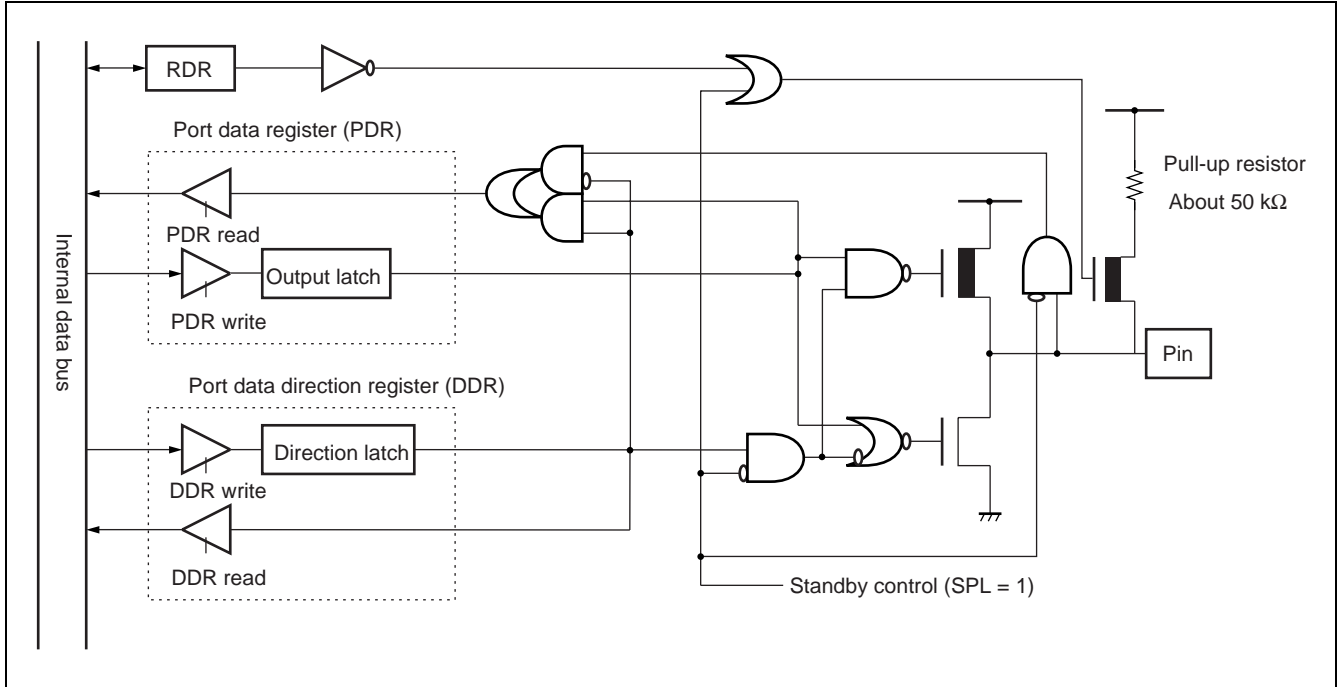

- Block diagram of port 3 pins

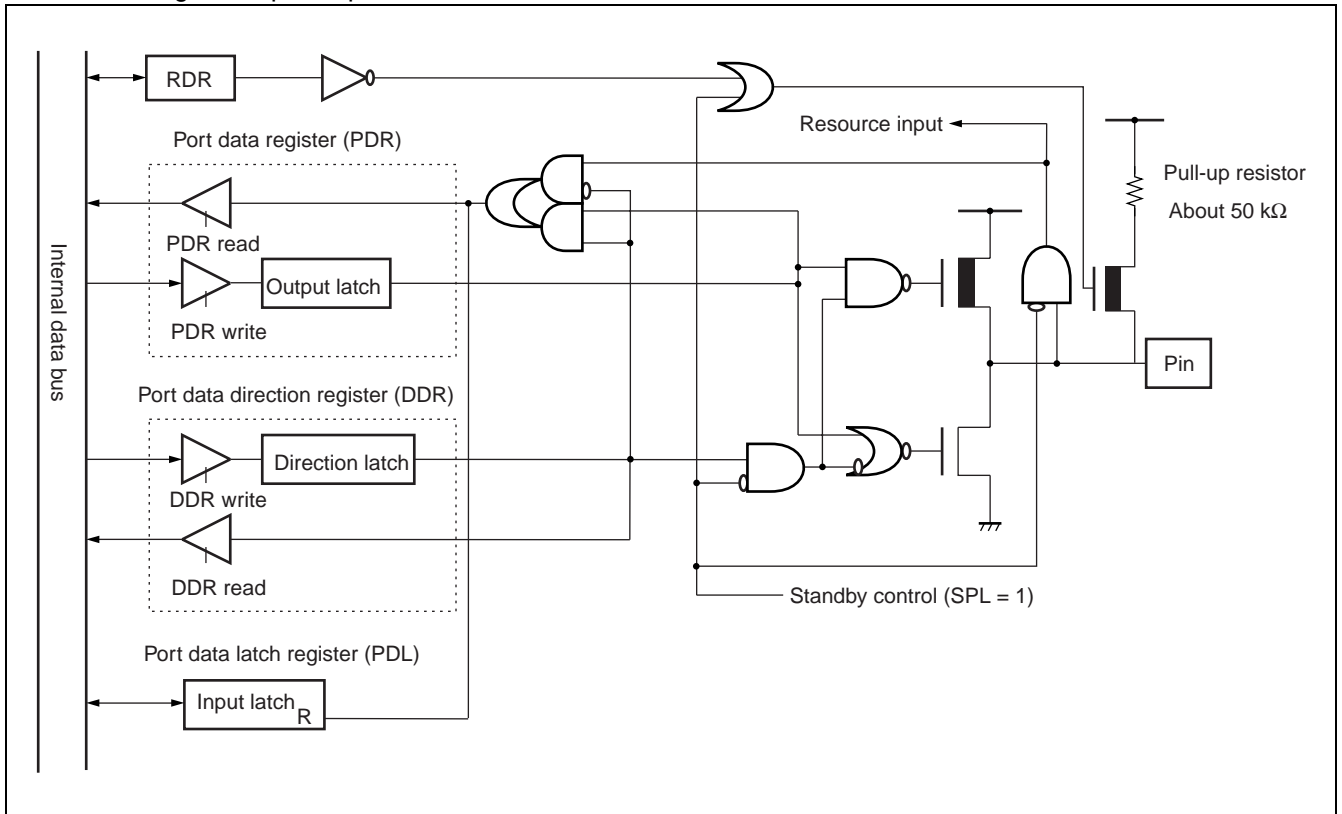

MB90370/375 Series

- Block diagram of port 47 pin

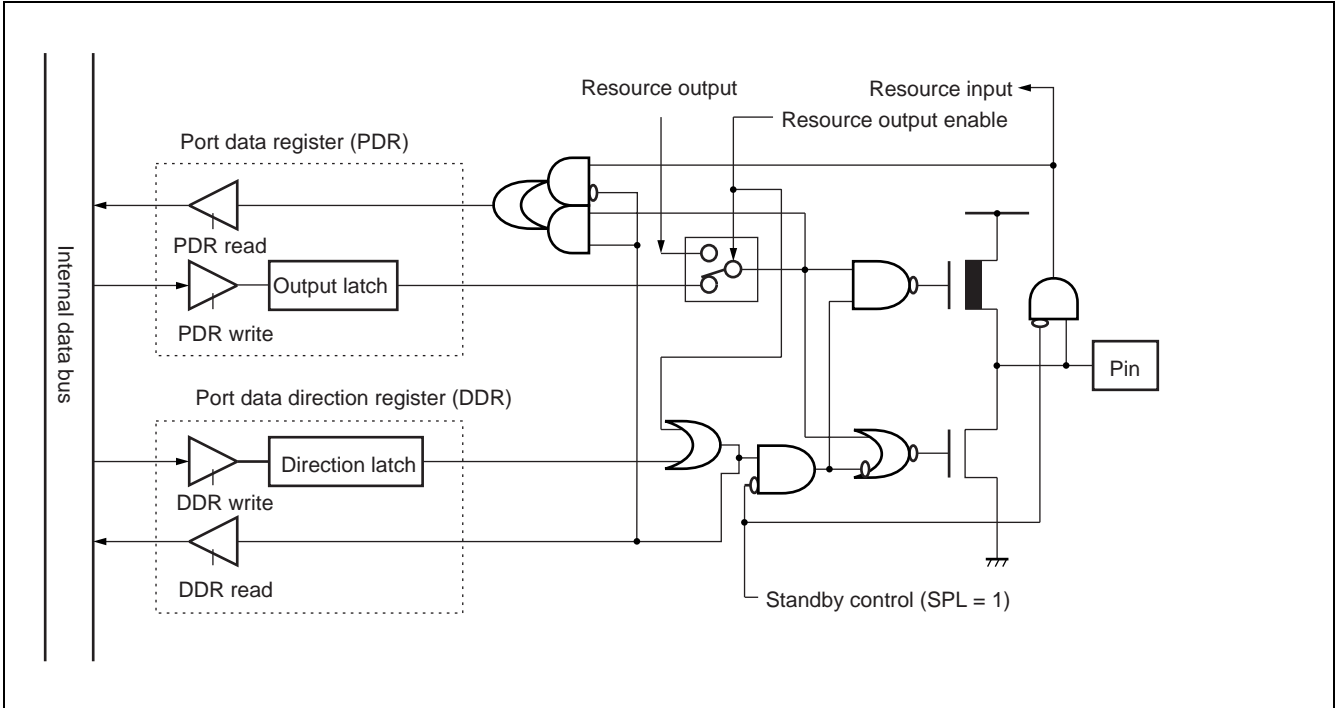

- Block diagram of port 46 pin

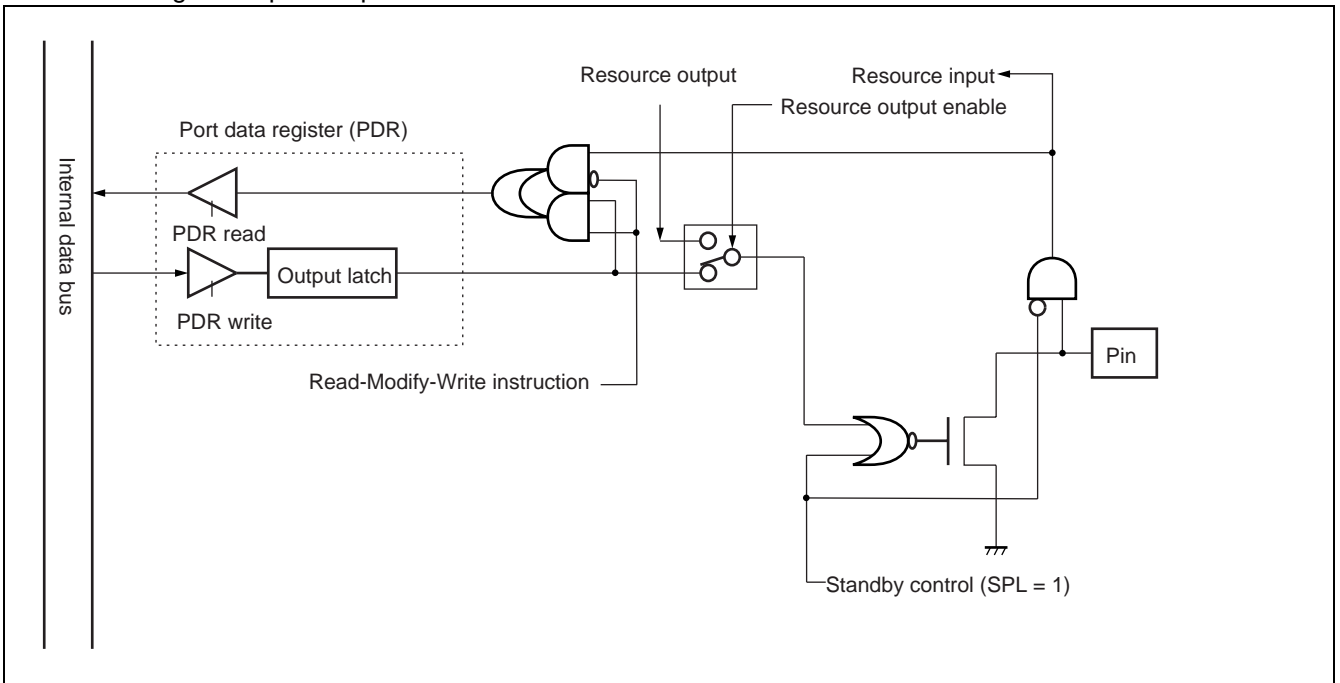

MB90370/375 Series

- Block diagram of port 45 to 40 pins

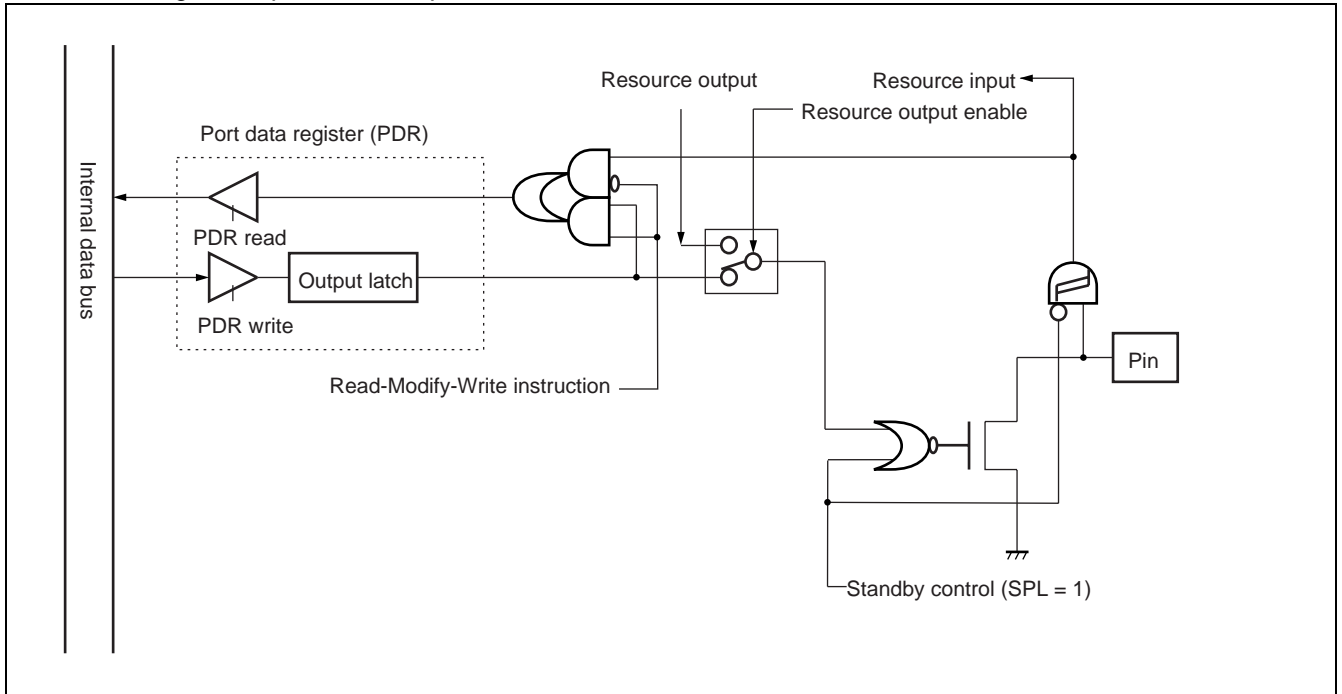

- Block diagram of port 5 pins

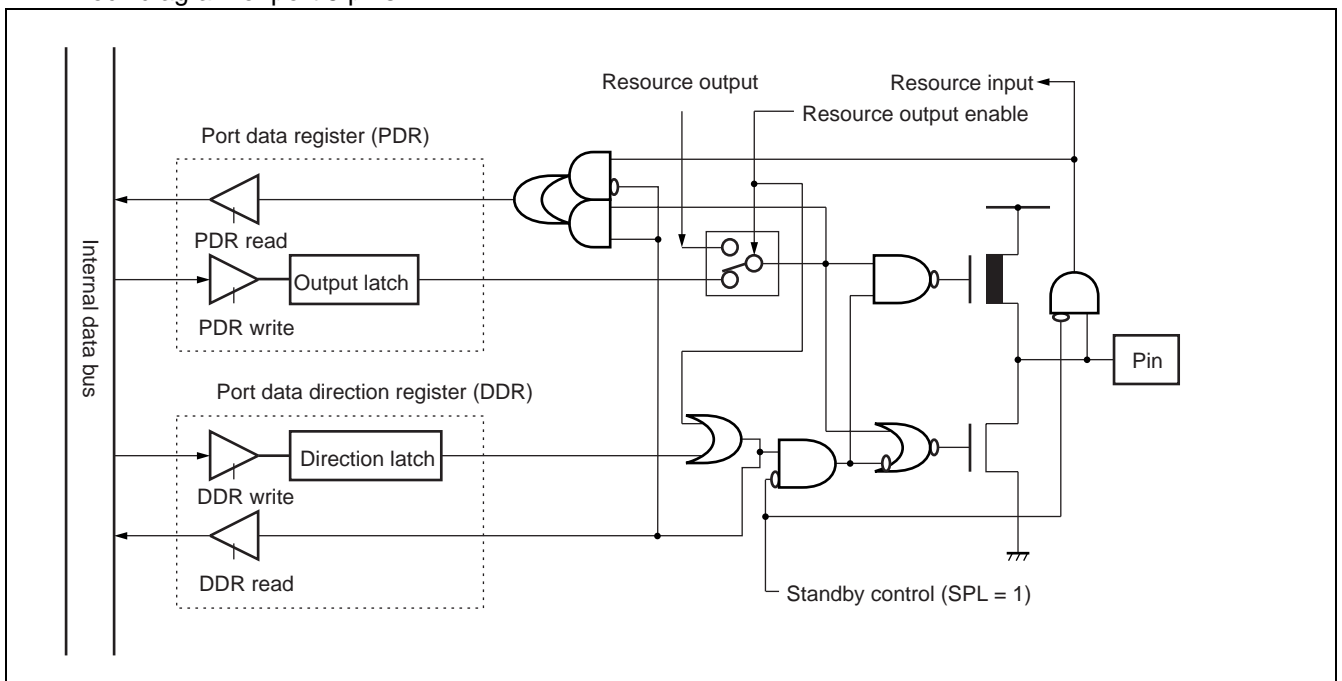

MB90370/375 Series

- Block diagram of port 6 pins

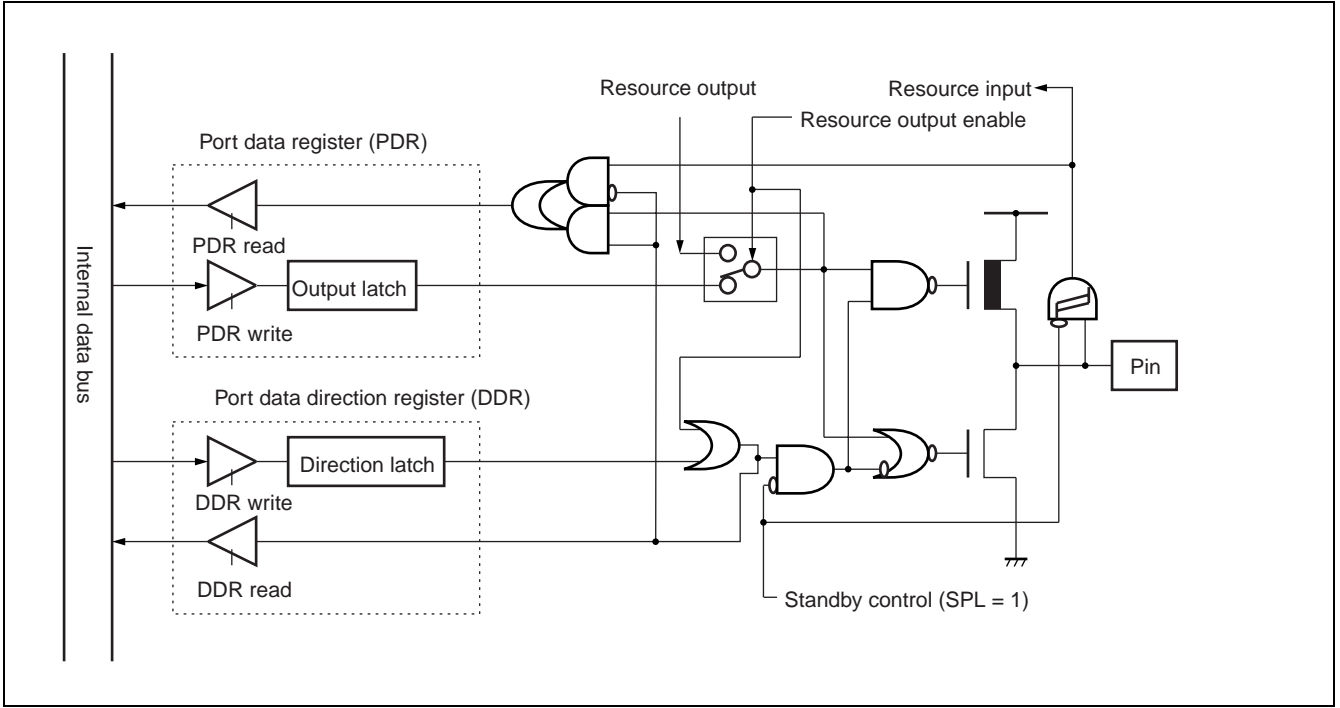

- Block diagram of port 7 pins

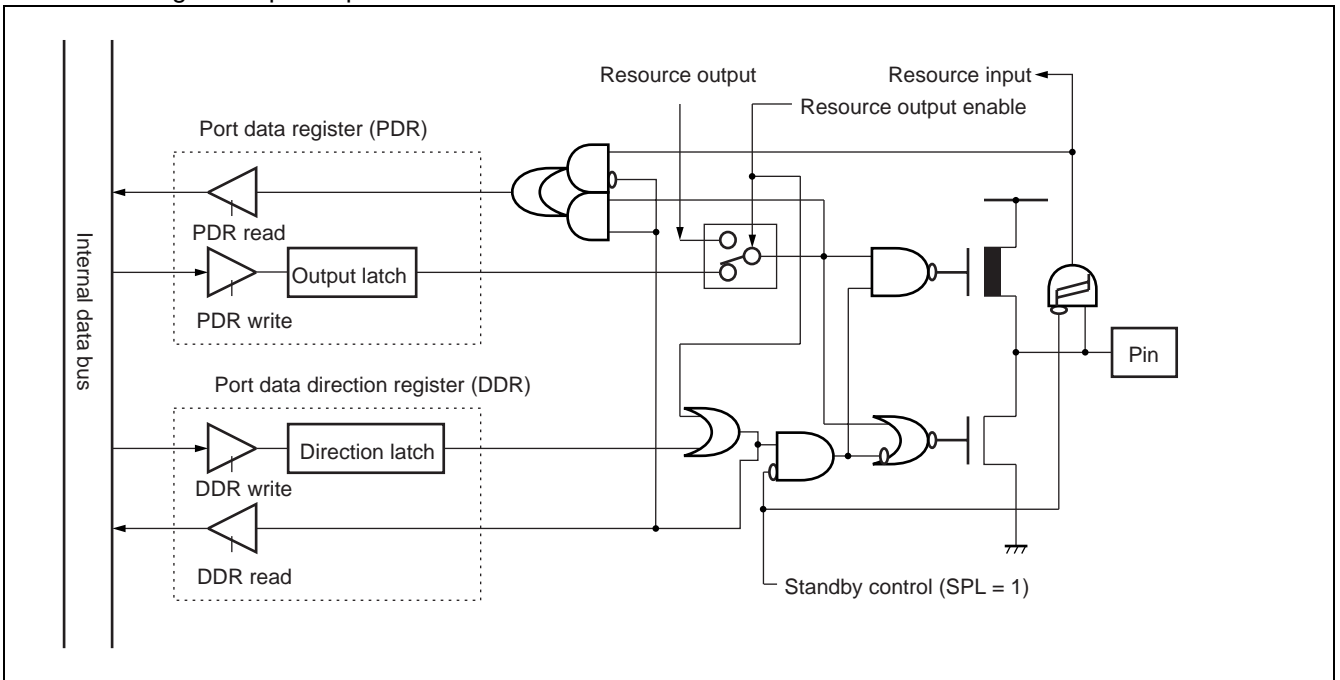

MB90370/375 Series

- Block diagram of port 8 pins

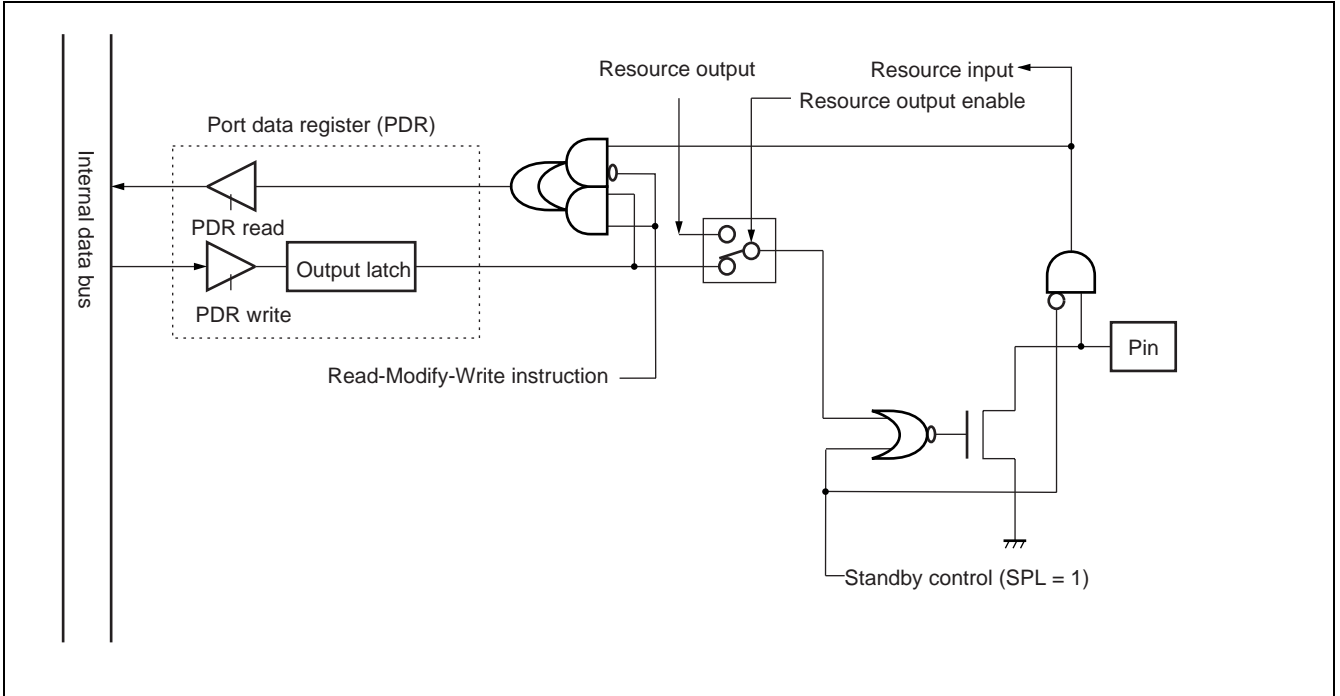

- Block diagram of port 9 pins

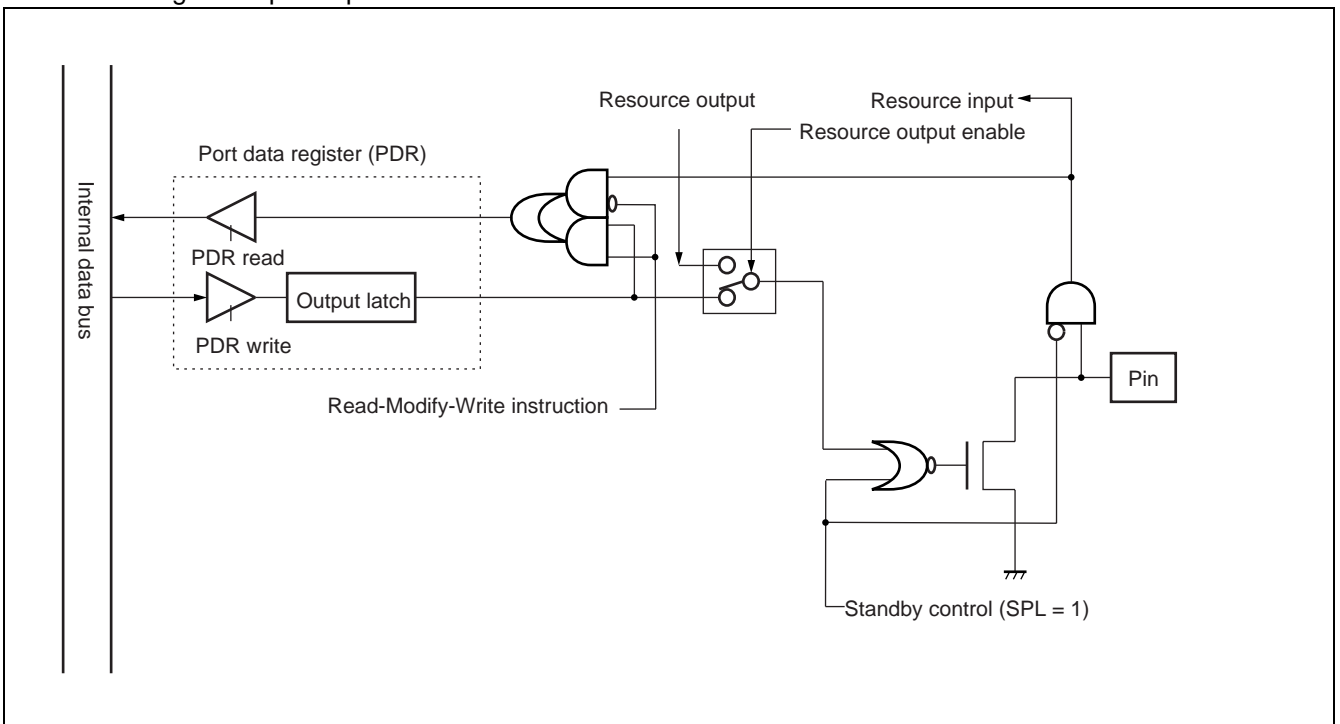

MB90370/375 Series

- Block diagram of port A pins

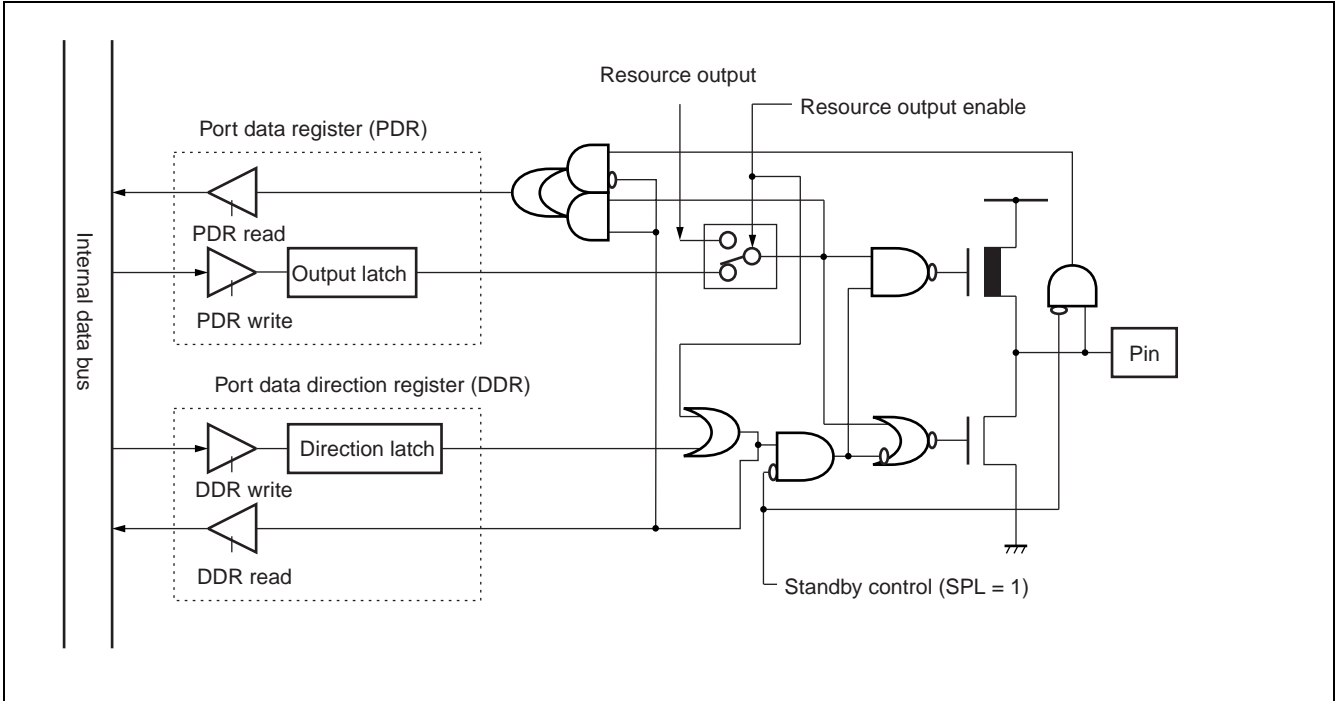

- Block diagram of port B pins

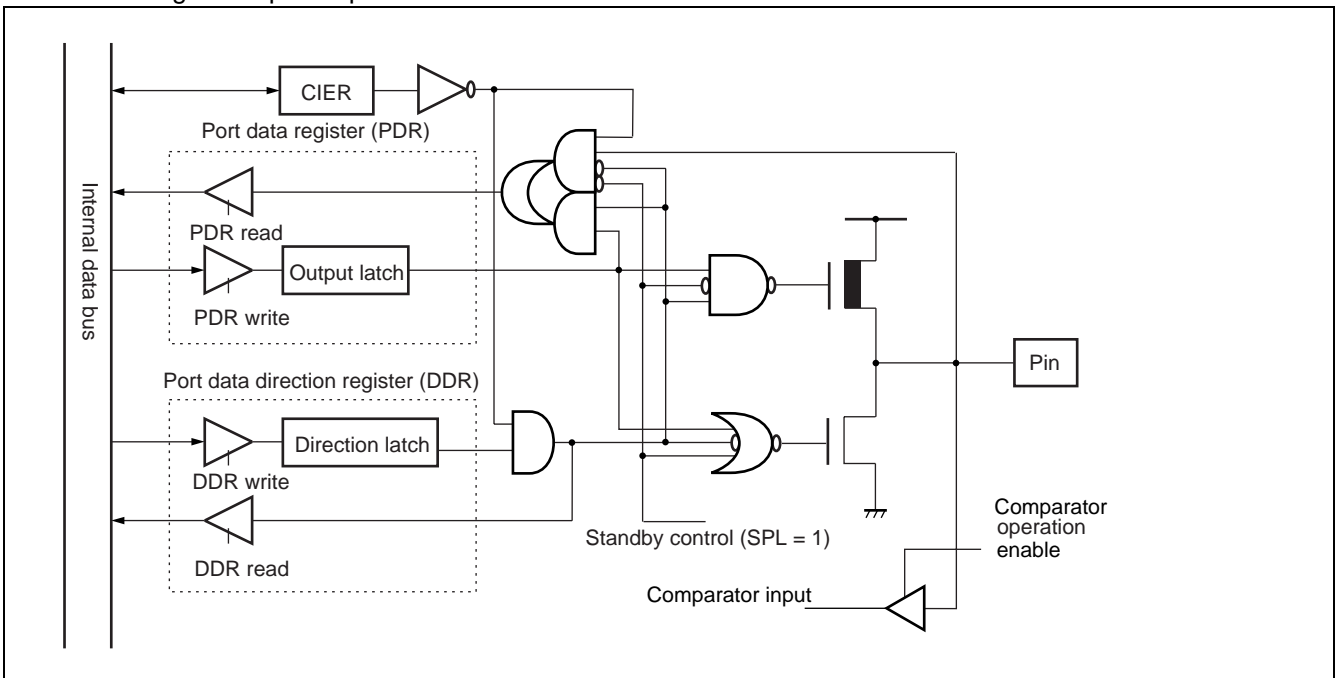

MB90370/375 Series

- Block diagram of port C7 to C3 pins

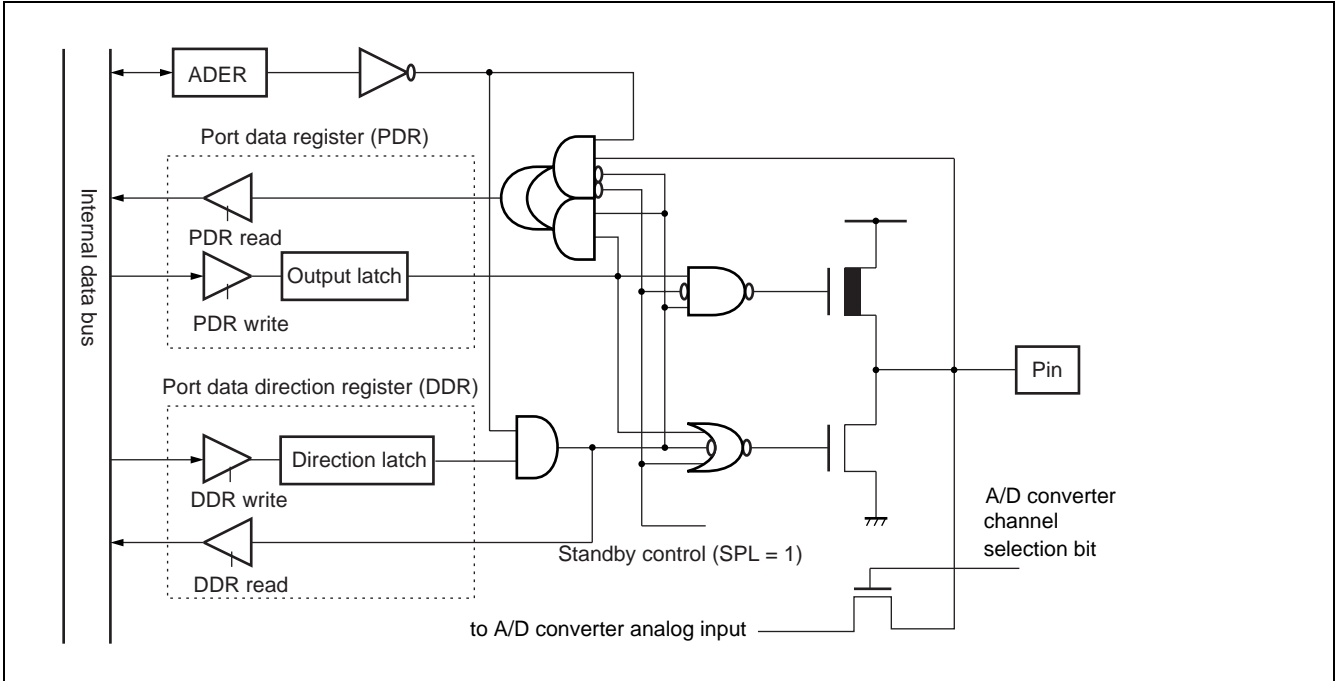

- Block diagram of port C2 to C0 pins

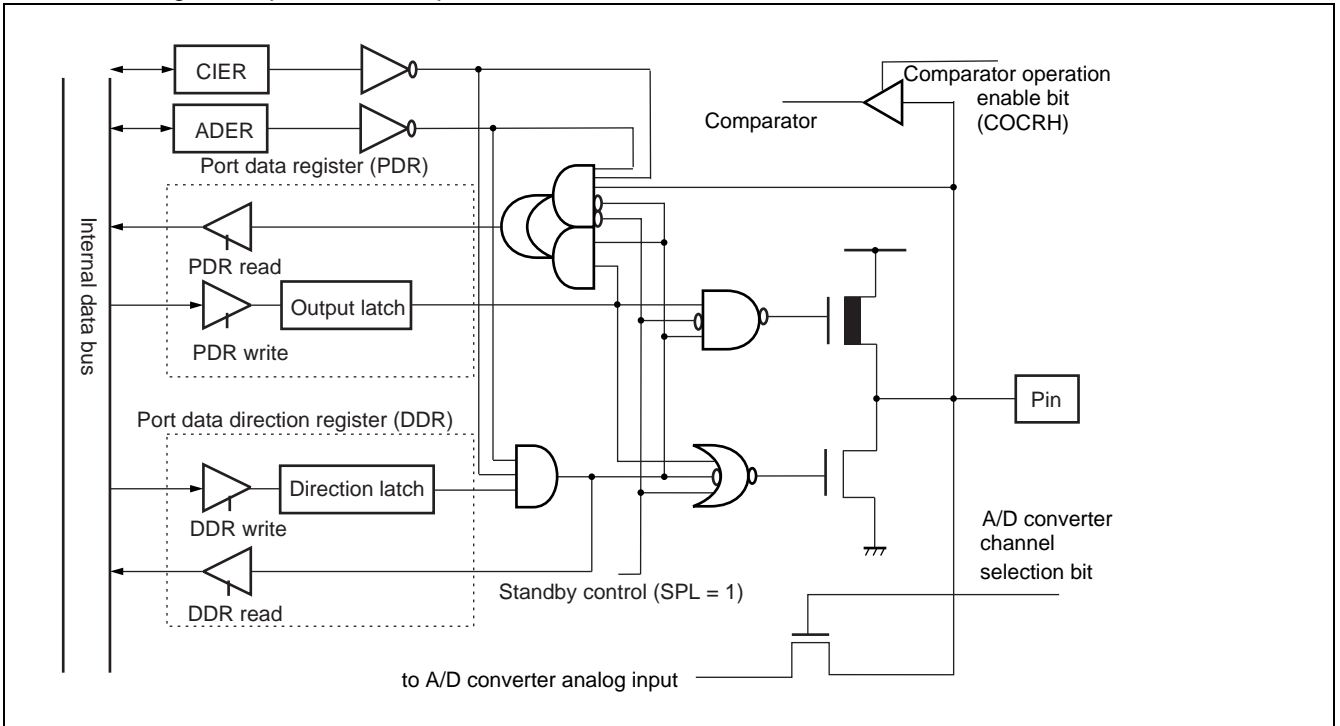

MB90370/375 Series

- Block diagram of port D7 and D6 pins

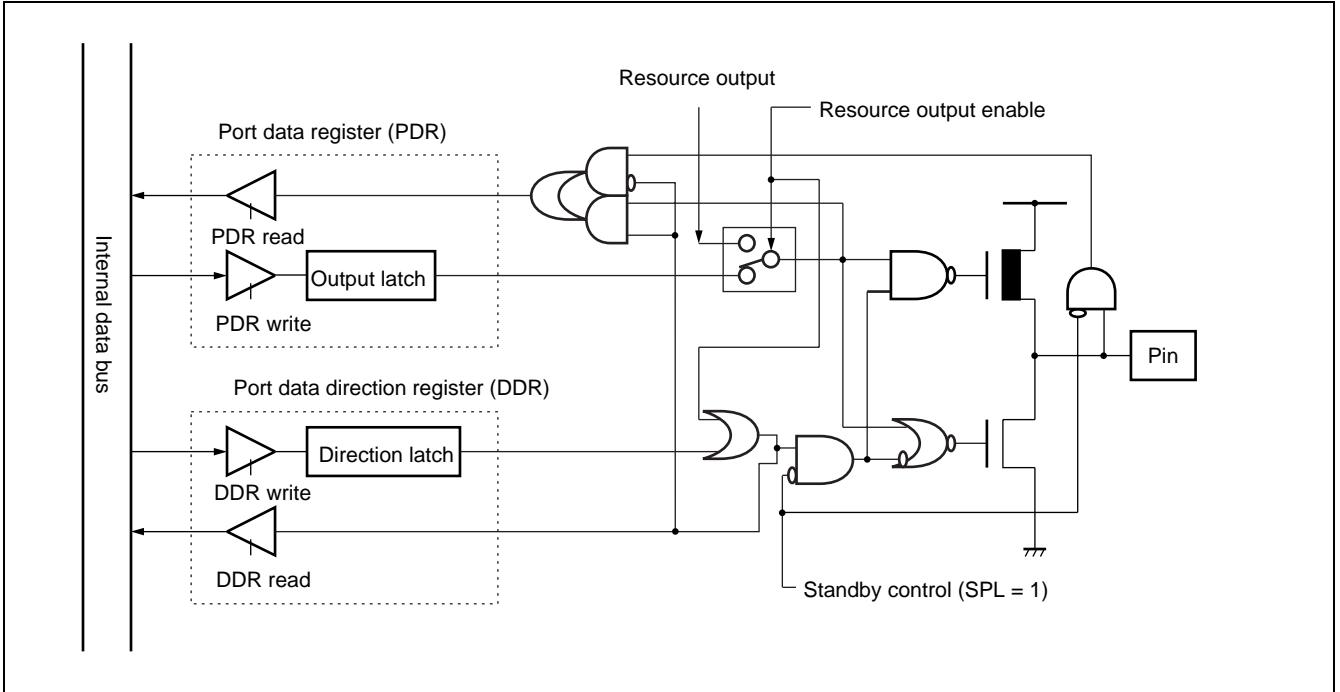

- Block diagram of port D5 and D4 pins

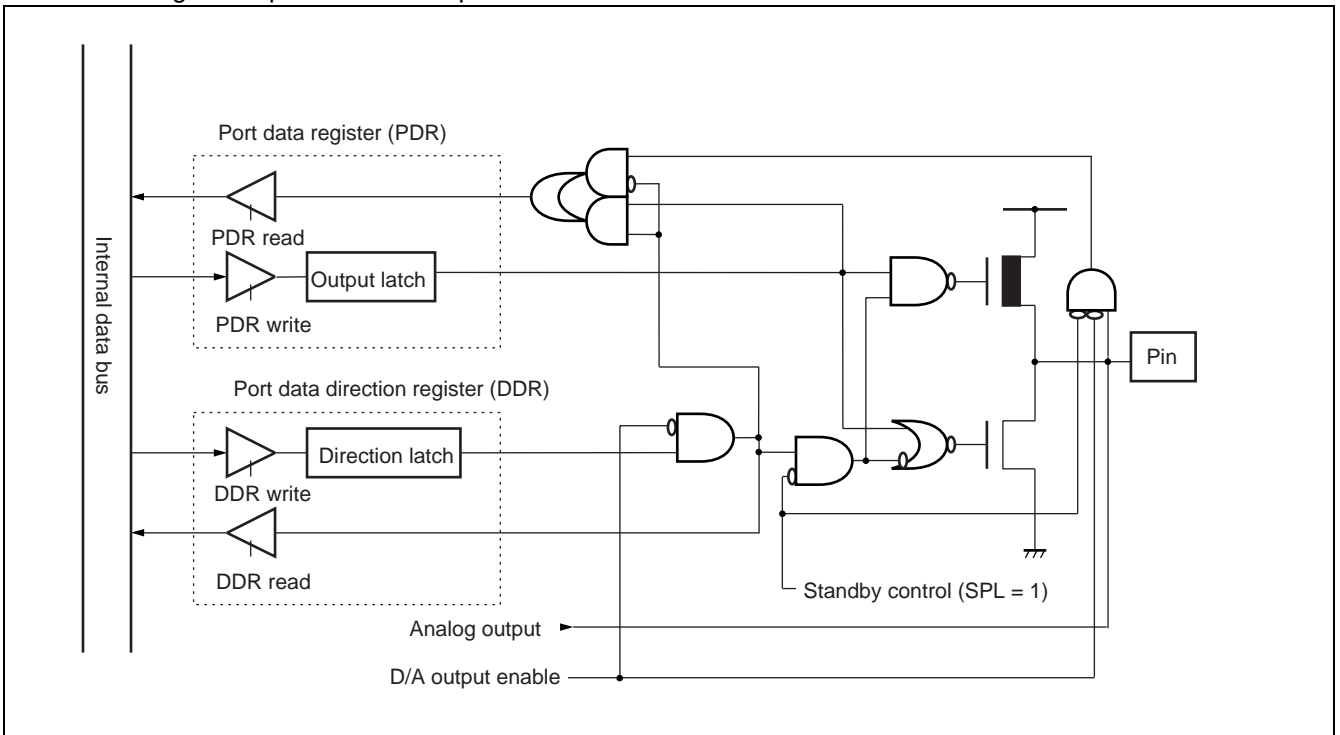

MB90370/375 Series

- Block diagram of port D3 to D0 pins

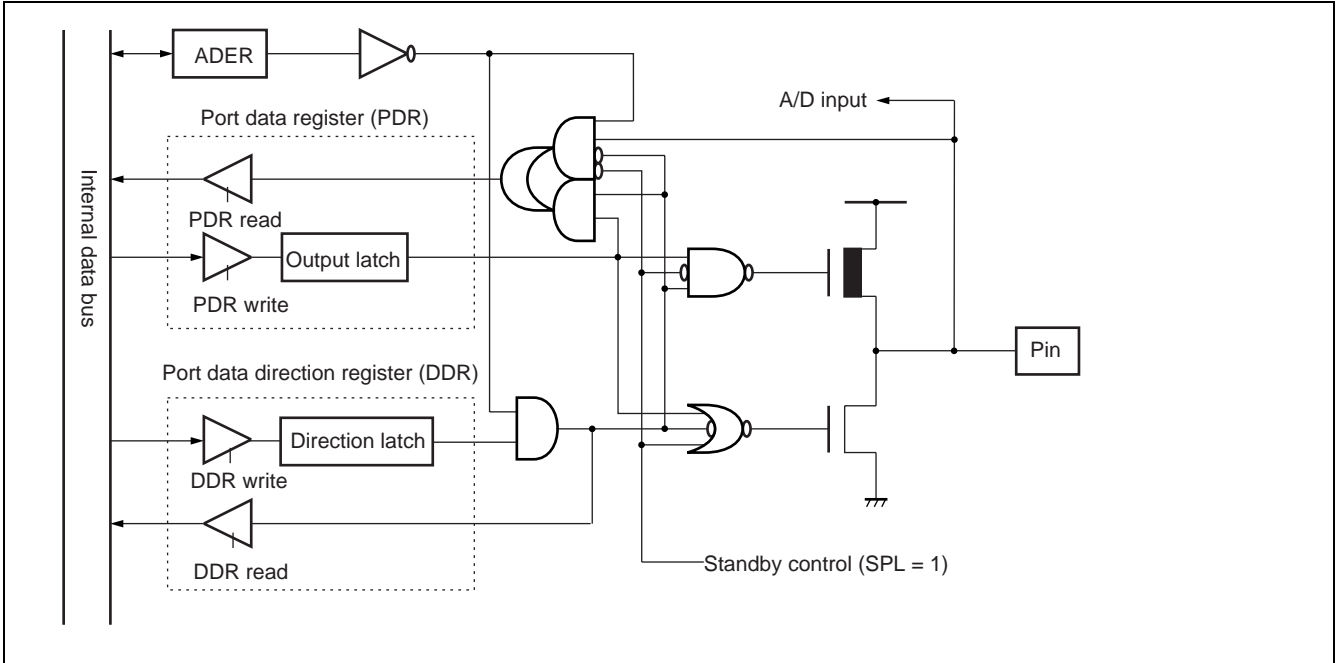

- Block diagram of port E pins (not for MB90F377)

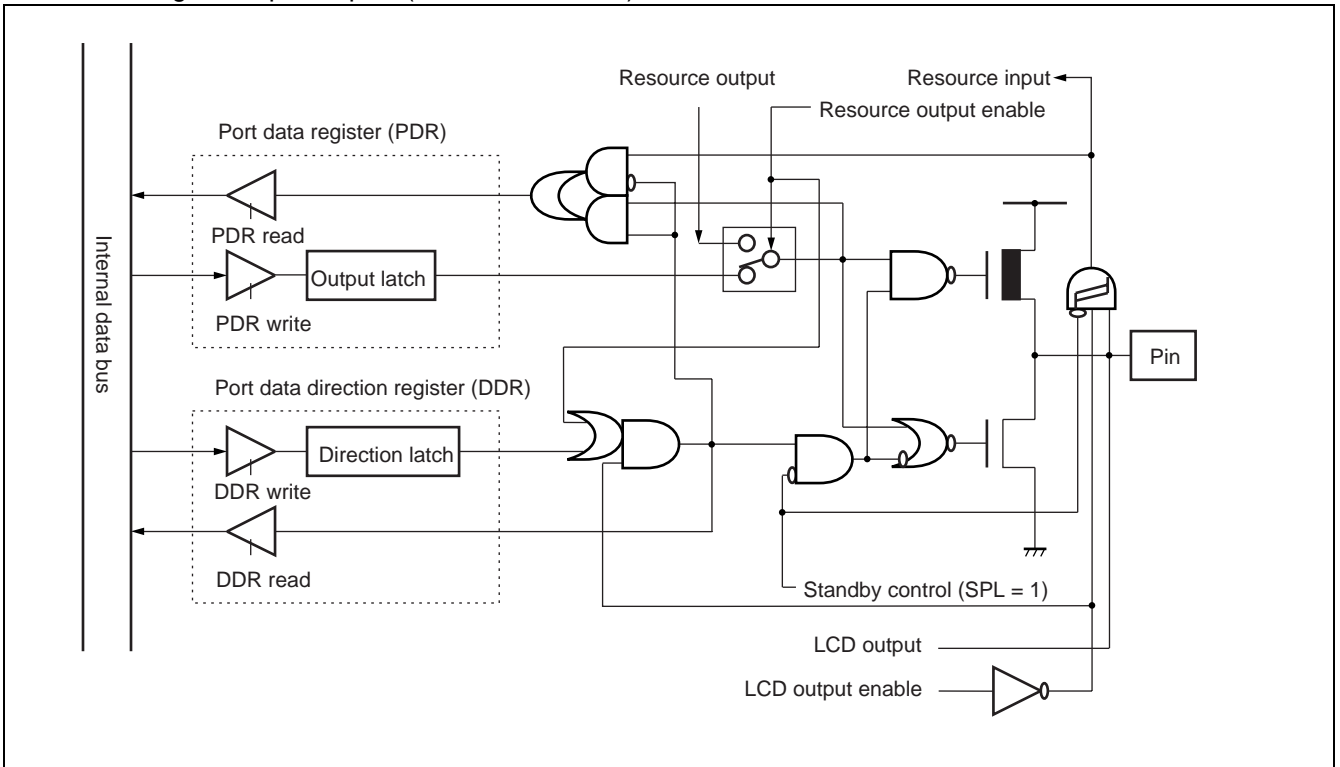

MB90370/375 Series

- Block diagram of port F7 to F5 pins (not for MB90F377)

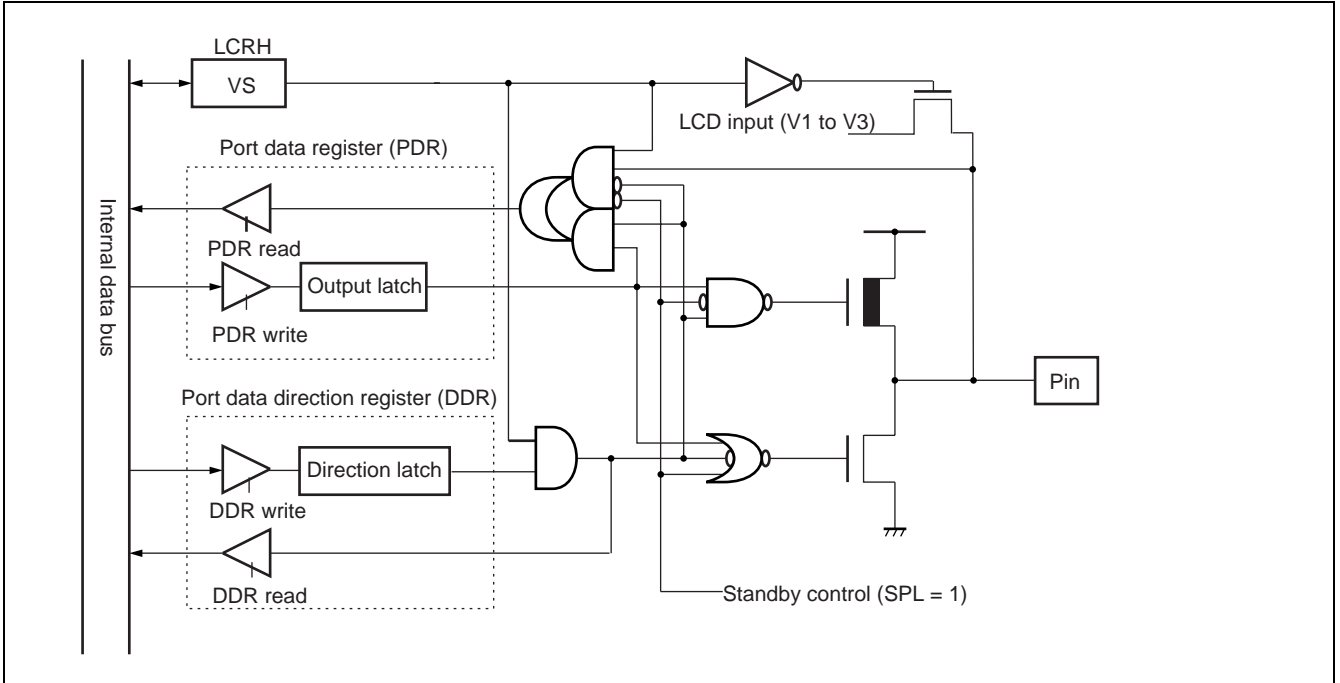

- Block diagram of port F4 to F0 pins (not for MB90F377)

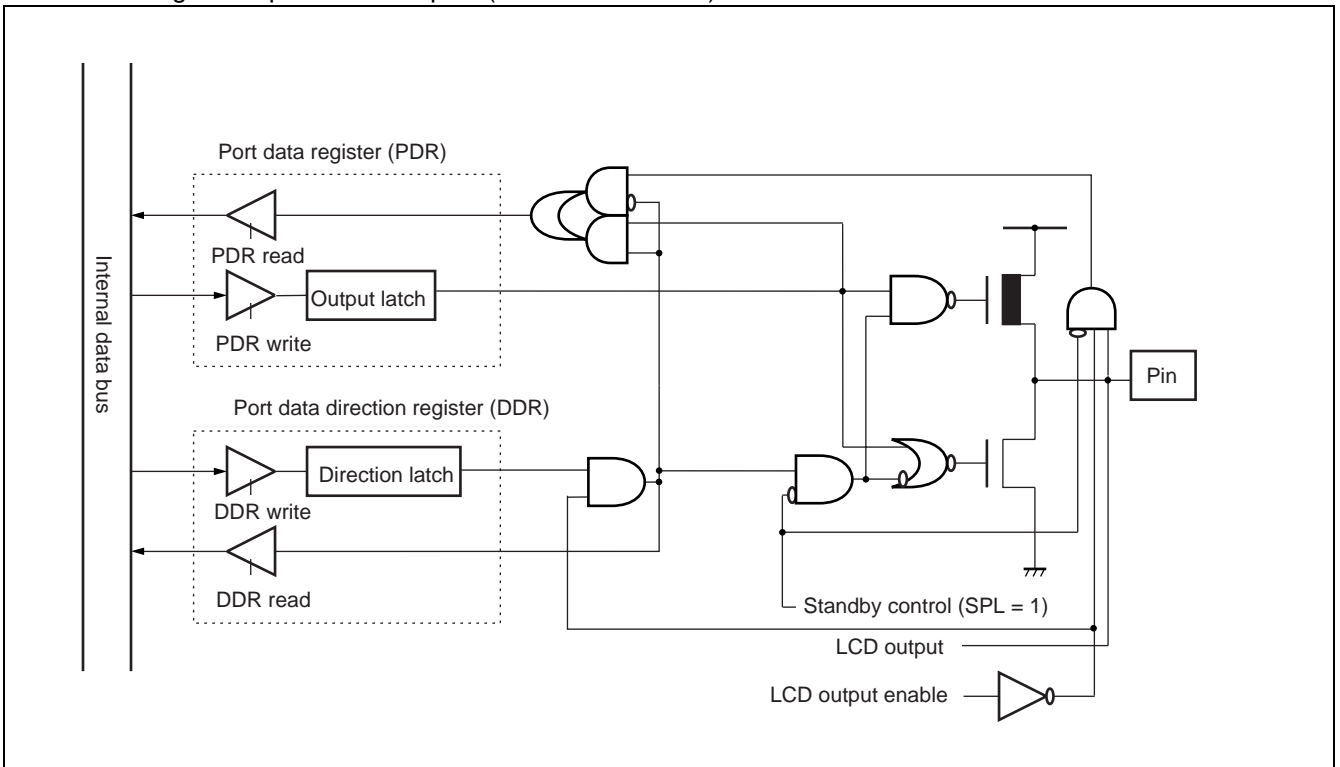

MB90370/375 Series

3. Timebase timer

The timebase timer is an 18-bit free-running counter (timebase counter) that counts up in synchronization with the internal count clock (one-half of the source oscillation).

Features of timebase timer :

- Interrupt generated when counter overflow
- EI²OS supported
- Interval timer function :
An interrupt generated at four different time intervals
- Clock supply function :
Four different clocks can be selected as watchdog timer's count clock.
Supply clock for oscillation stabilization

(1) Register configuration

Timebase Timer Control Register									Bit number	
Address : 0000A9 _H	15	14	13	12	11	10	9	8	⇐	TBTC
Read/write	⇒ R/W	—	—	R/W	R/W	R/W	R/W	R/W		
Initial value	⇒ 1	—	—	0	0	1	0	0		

(2) Block diagram of timebase timer

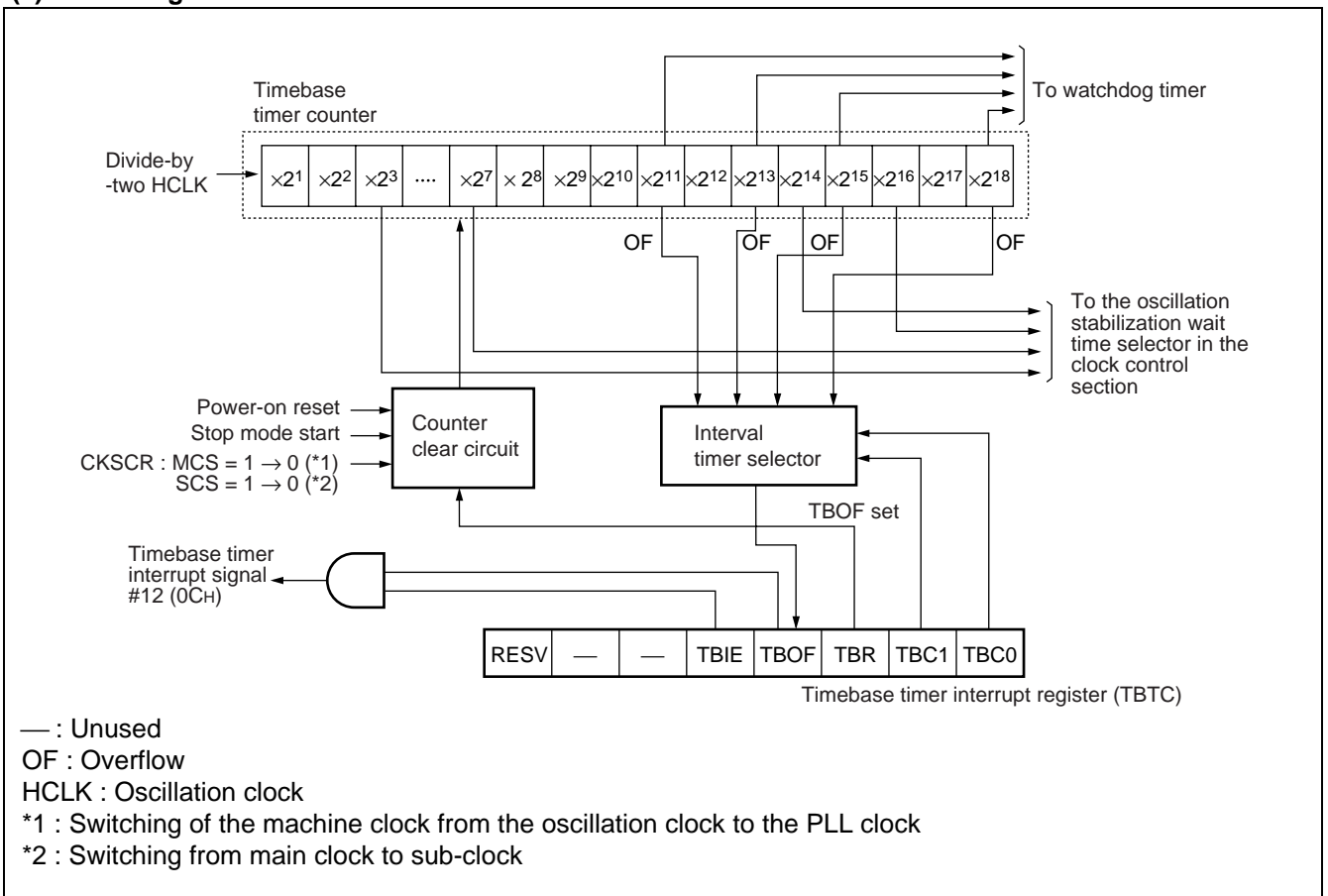

4. Watchdog timer

The watchdog timer is a 2-bit counter that uses the timebase timer's supply clock as the count clock. After activation, if the watchdog timer is not cleared within a given period, the CPU will be reset.

- Features of watchdog timer :
 - Reset CPU at four different time intervals
 - Status bits to indicate the reset causes

(1) Register configuration of watchdog timer

Watchdog Timer Control Register								Bit number	
Address : 0000A8H	7	6	5	4	3	2	1	0	WDTC
	PONR	—	WRST	ERST	SRST	WTE	WT1	WT0	
Read/write	R	—	R	R	R	W	W	W	
Initial value	X	—	X	X	X	1	1	1	

(2) Block diagram of watchdog timer

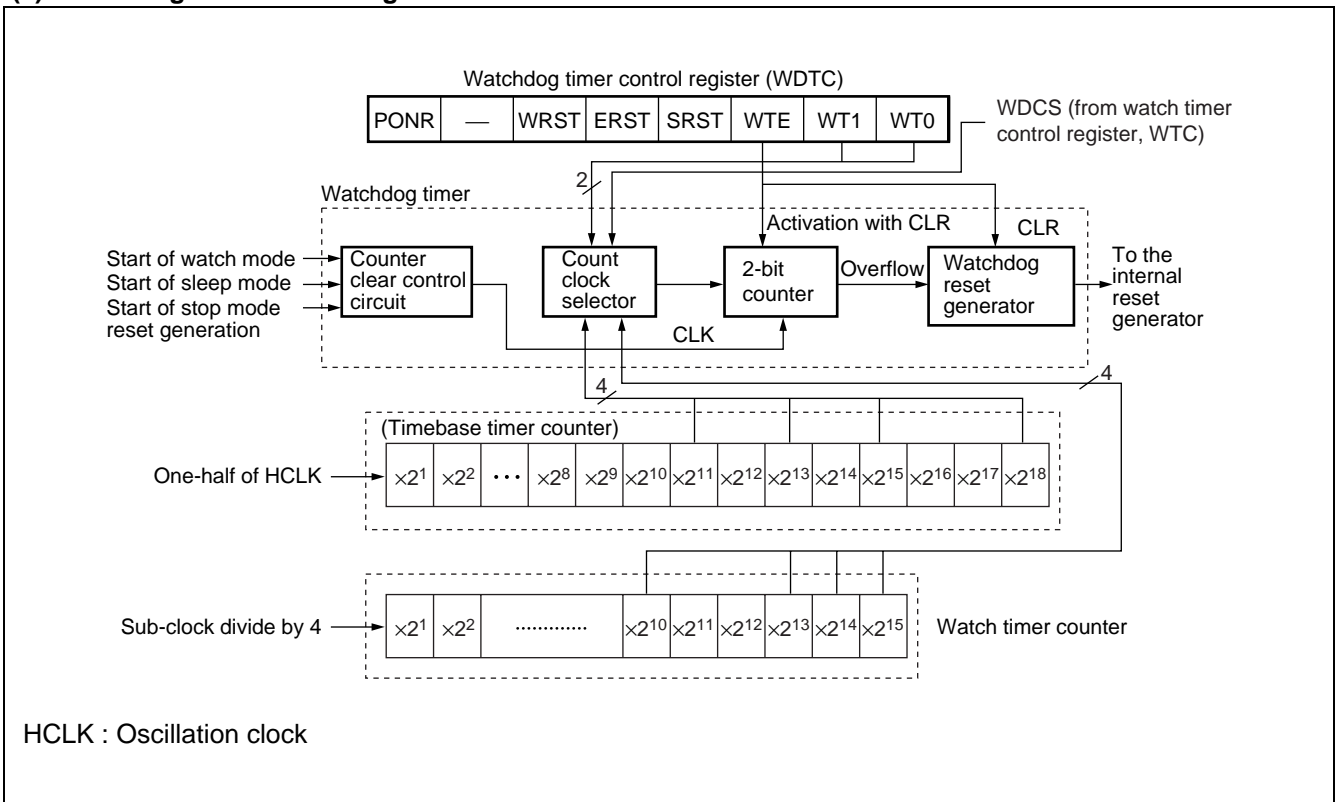

MB90370/375 Series

5. Watch timer

The watch timer is a 15-bit timer that uses sub-clocks and can generate an interval interrupt. It can also be used as the watchdog timer clock source and sub-clock oscillation wait time.

Features of the watch timer :

- Provides the watchdog timer clock source
- Sub-clock oscillation stabilization wait timer function
- Interval timer function that generates interrupts in a given cycle

(1) Register configuration of watch timer

Watch Timer Control Register								Bit number	
Address : 0000AA _H	7	6	5	4	3	2	1	0	← WTC
	WDCS	SCE	WTIE	WTOF	WTR	WTC2	WTC1	WTC0	
Read/write	⇒ R/W	R	R/W	R/W	W	R/W	R/W	R/W	
Initial value	⇒ 1	0	0	0	1	0	0	0	

(2) Block diagram of watch timer

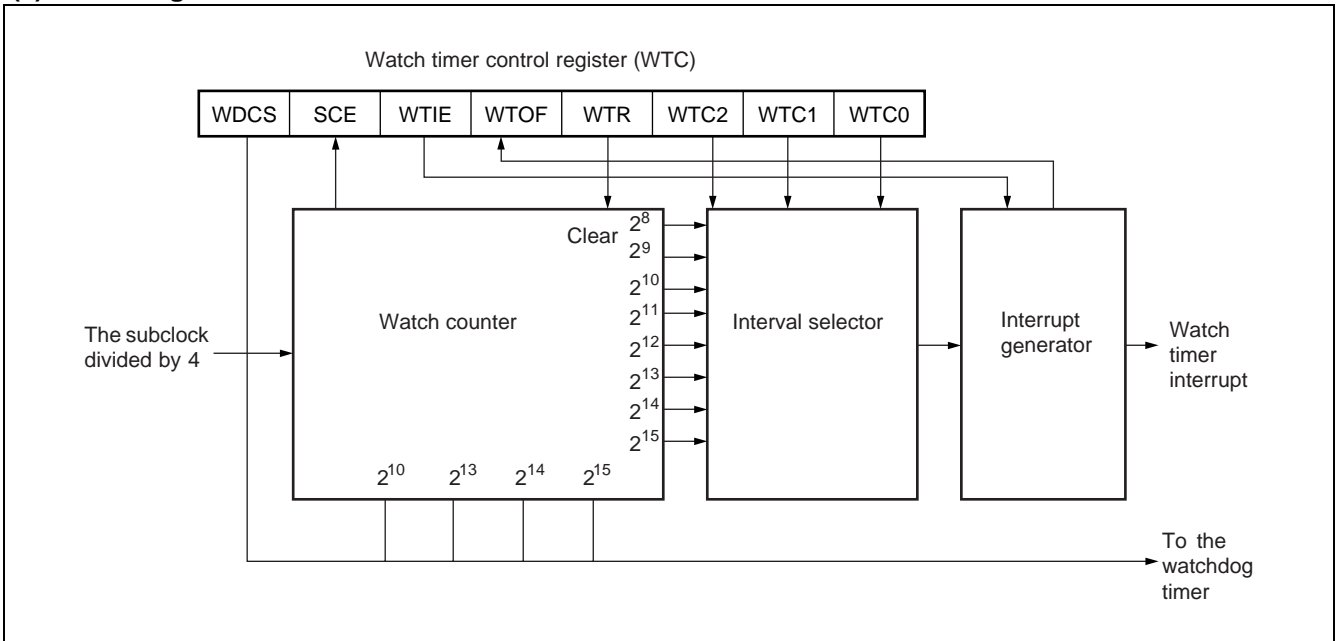

MB90370/375 Series

(Continued)

PPG Duty Setting Buffer Register (Upper)

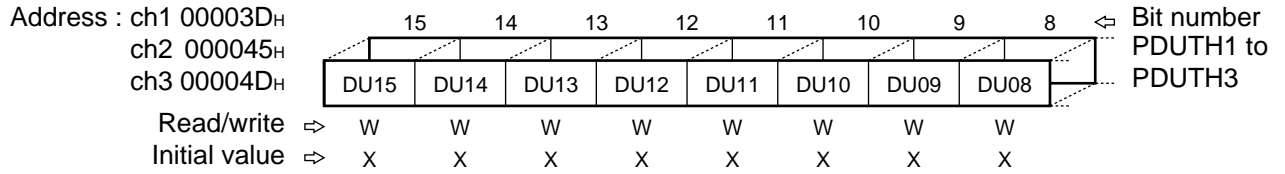

PPG Duty Setting Buffer Register (Lower)

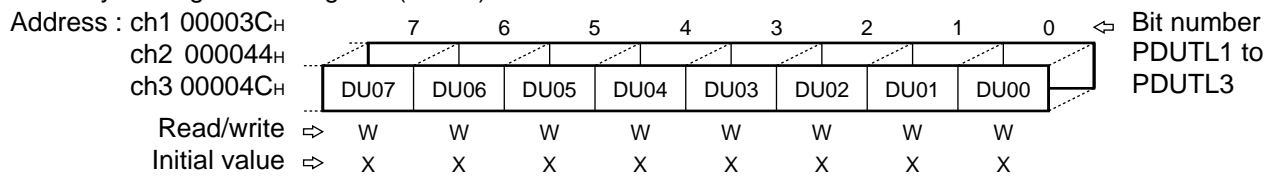

PPG Control Status Register (Upper)

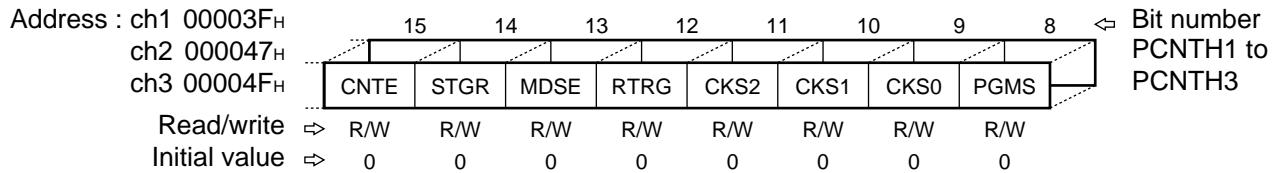

PPG Control Status Register (Lower)

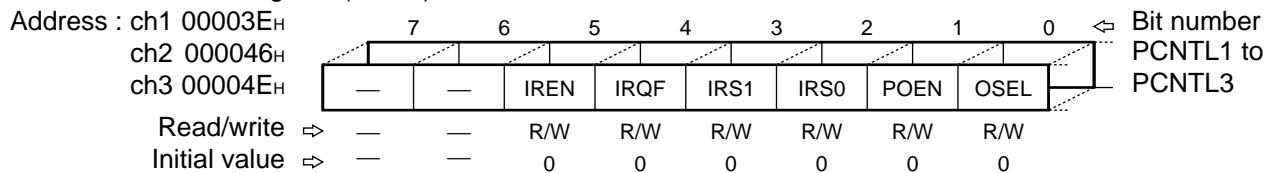

Note : Registers PDCR1 to PDCR3, PCSR1 to PCSR3 and PDUT1 to PDUT3 are word access only.

(2) Block diagram of PPG timer

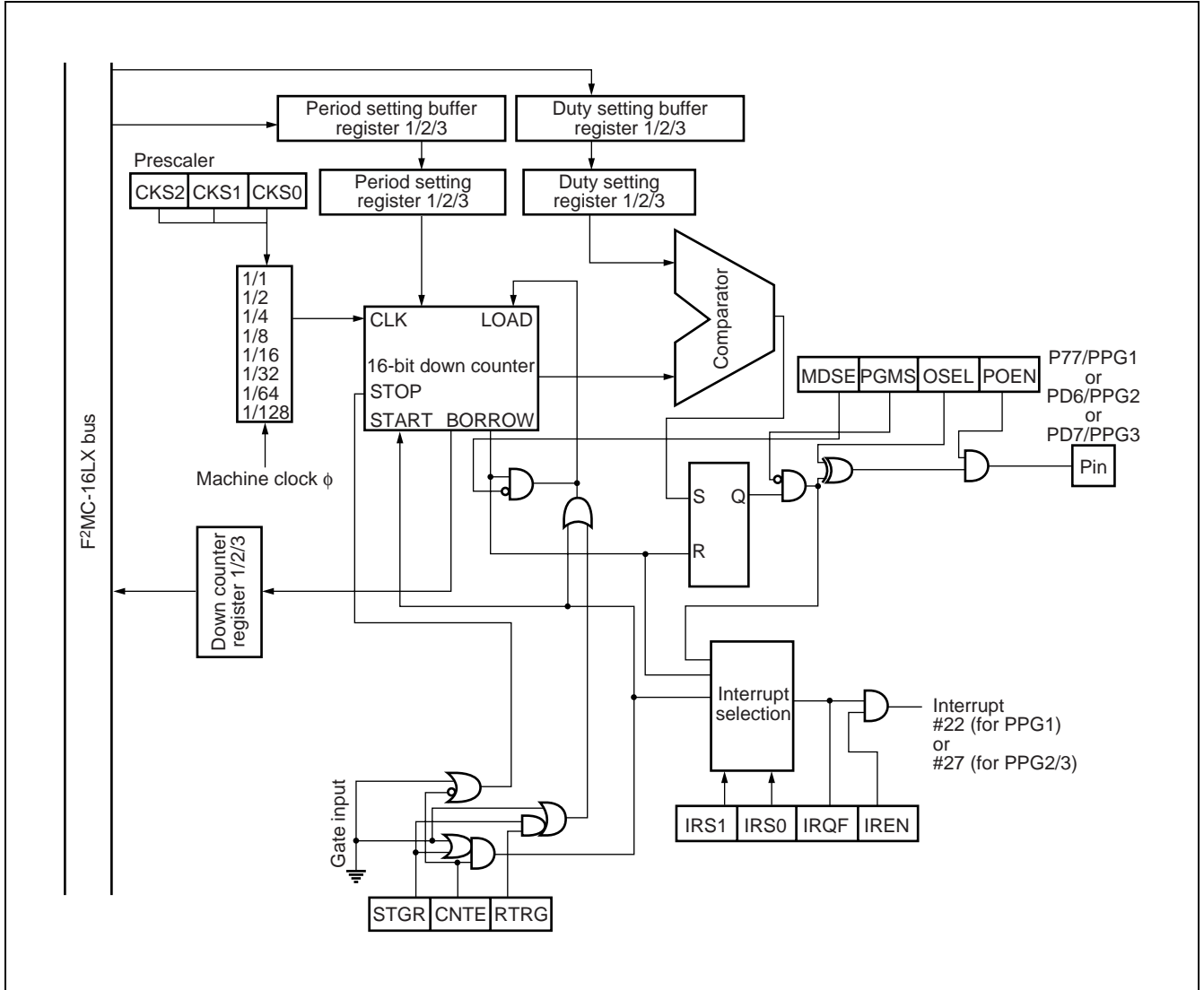

MB90370/375 Series

7. 16-bit reload timer (× 4)

The 16-bit reload timer provides two operating modes, internal clock mode and event count mode. In each operating mode, the 16-bit down counter can be reloaded (reload mode) or stopped when underflow (one-shot mode).

Output pins TO1 to TO4 are able to output different waveform according to the counter operating mode. TO1 to TO4 toggles when counter underflow if counter is operated as reload mode. TO1 to TO4 output specified level (“H” or “L”) when counter is counting if the counter is in one-shot mode.

Features of the 16-bit reload timer :

- Interrupt generated when timer underflow
- EI²OS supported
- Internal clock operating mode :
Three internal count clocks can be selected.
Counter can be activated by software or external trigger (signal at TIN1 to TIN4 pin) .
Counter can be reloaded or stopped when underflow after activated.
- Event count operating mode :
Counter counts down by one when specified edge at TIN1 to TIN4 pin.
Counter can be reloaded or stopped when underflow.

(1) Register configuration of reload timer

Timer Control Status Register (Upper)

Address : ch1 000071H	15	14	13	12	11	10	9	8	↔ Bit number
ch2 000075H	—	—	—	—	CSL1	CSL0	MOD2	MOD1	TMCSRH1 to
ch3 000079H	—	—	—	—	CSL1	CSL0	MOD2	MOD1	TMCSRH4
ch4 00007DH	—	—	—	—	CSL1	CSL0	MOD2	MOD1	
Read/write	⇒ —	⇒ —	⇒ —	⇒ —	⇒ R/W	⇒ R/W	⇒ R/W	⇒ R/W	
Initial value	⇒ —	⇒ —	⇒ —	⇒ —	⇒ 0	⇒ 0	⇒ 0	⇒ 0	

Timer Control Status Register (Lower)

Address : ch1 000070H	7	6	5	4	3	2	1	0	↔ Bit number
ch2 000074H	MOD0	OUTE	OUTL	RELD	INTE	UF	CNTE	TRG	TMCSRL1 to
ch3 000078H	MOD0	OUTE	OUTL	RELD	INTE	UF	CNTE	TRG	TMCSRL4
ch4 00007CH	MOD0	OUTE	OUTL	RELD	INTE	UF	CNTE	TRG	
Read/write	⇒ R/W	⇒ R/W	⇒ R/W	⇒ R/W	⇒ R/W	⇒ R/W	⇒ R/W	⇒ R/W	
Initial value	⇒ 0	⇒ 0	⇒ 0	⇒ 0	⇒ 0	⇒ 0	⇒ 0	⇒ 0	

16-bit Timer Register / 16-bit Reload Register (Upper)

Address : ch1 000073H	15	14	13	12	11	10	9	8	↔ Bit number
ch2 000077H	D15	D14	D13	D12	D11	D10	D09	D08	TMR1 to TMR4/
ch3 00007BH	D15	D14	D13	D12	D11	D10	D09	D08	TMRD1 to
ch4 00007FH	D15	D14	D13	D12	D11	D10	D09	D08	TMRD4
Read/write	⇒ R/W	⇒ R/W	⇒ R/W	⇒ R/W	⇒ R/W	⇒ R/W	⇒ R/W	⇒ R/W	
Initial value	⇒ X	⇒ X	⇒ X	⇒ X	⇒ X	⇒ X	⇒ X	⇒ X	

16-bit Timer Register / 16-bit Reload Register (Lower)

Address : ch1 000072H	7	6	5	4	3	2	1	0	↔ Bit number
ch2 000076H	D07	D06	D05	D04	D03	D02	D01	D00	TMR1 to TMR4/
ch3 00007AH	D07	D06	D05	D04	D03	D02	D01	D00	TMRD1 to
ch4 00007EH	D07	D06	D05	D04	D03	D02	D01	D00	TMRD4
Read/write	⇒ R/W	⇒ R/W	⇒ R/W	⇒ R/W	⇒ R/W	⇒ R/W	⇒ R/W	⇒ R/W	
Initial value	⇒ X	⇒ X	⇒ X	⇒ X	⇒ X	⇒ X	⇒ X	⇒ X	

(2) Block diagram of reload timer

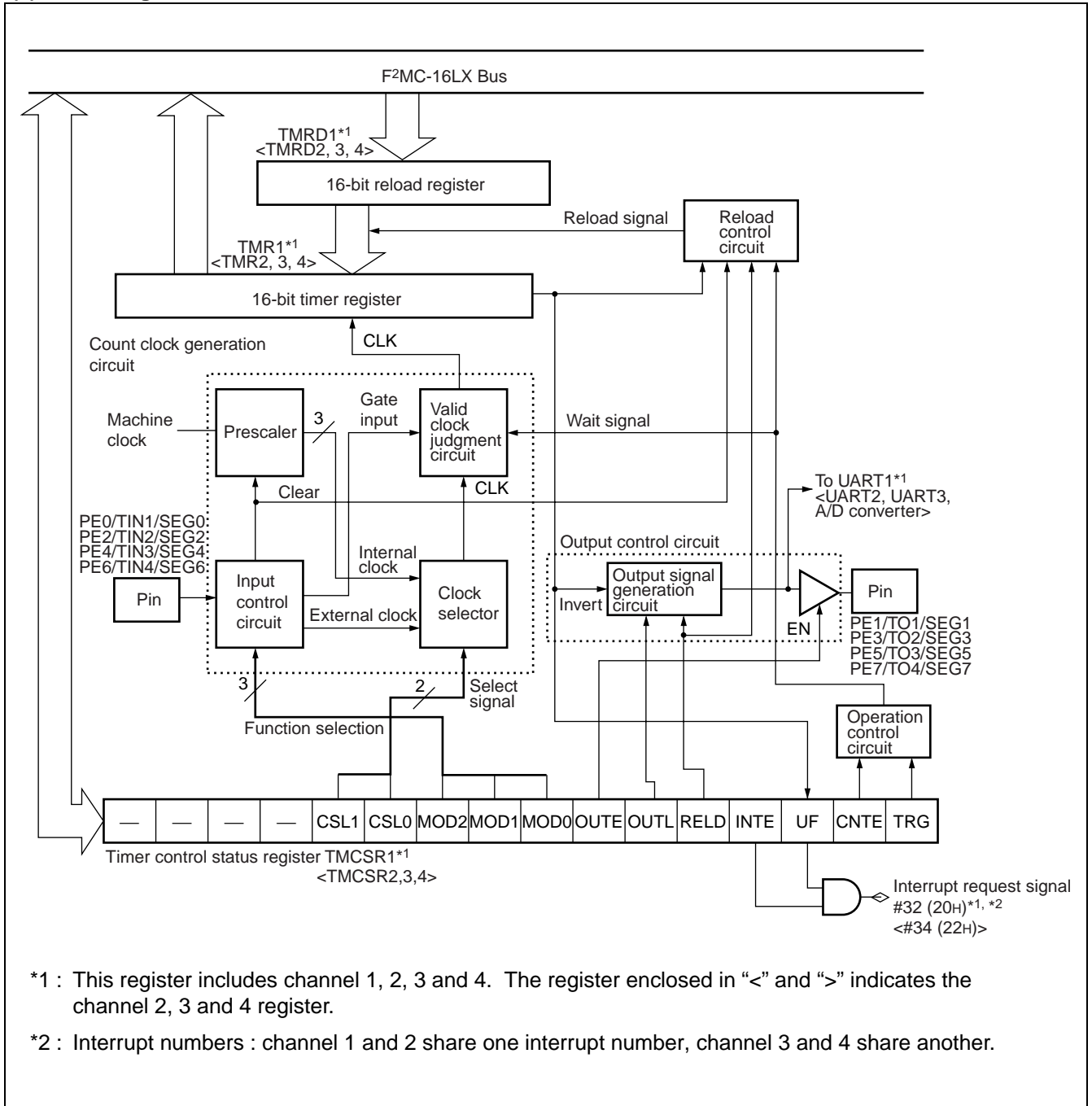

MB90370/375 Series

8. I²C

The I²C (Inter IC Bus) interface is a simple structure bidirectional bus consisting of two wires : a serial data line (SDA) and a serial clock line (SCL) . Among the devices connected with these two wires, information is transmitted to one another. By recognizing the unique address of each device, it can operate as a transmitting or receiving device in accordance with the function of each device. Among these devices, the master/slave relation is established.

The I²C interface can connect two or more devices to the bus provided the upper limit of the bus capacitance does not exceed 400 pF. It is a full-fledged multi-master bus equipped with collision detection and communication adjustment procedures designed to avoid the destruction of data if two or more masters attempt to start data transfer simultaneously.

The communication adjustment procedure permits only one master to control the bus when two or more masters attempt to control the bus so that messages are not lost or the contents of messages are not changed. Multi-master means that multiple masters attempt to control the bus simultaneously without losing messages.

This I²C interface includes MCU standby mode wake-up function, and a CRC-8 calculator that performs automatic Packet Error Code (PEC) generation and verification.

(1) Register configuration of I²C

I ² C Bus Control Register (Lower)									
Address : 000080H	7	6	5	4	3	2	1	0	↔ Bit number IBCRL
	—	—	—	—	RES	PECE	LBT	WUE	
Read/write	⇒ —	⇒ —	⇒ —	⇒ —	⇒ R/W	⇒ R/W	⇒ R/W	⇒ R/W	
Initial value	⇒ —	⇒ —	⇒ —	⇒ —	⇒ 0	⇒ 0	⇒ 0	⇒ 0	
I ² C Bus Control Register (Upper)									
Address : 000081H	15	14	13	12	11	10	9	8	↔ Bit number IBCRH
	BER	BEIE	SCC	MSS	ACK	GCAA	INTE	INT	
Read/write	⇒ R/W	⇒ R/W	⇒ R/W	⇒ R/W	⇒ R/W	⇒ R/W	⇒ R/W	⇒ R/W	
Initial value	⇒ 0	⇒ 0	⇒ 0	⇒ 0	⇒ 0	⇒ 0	⇒ 0	⇒ 0	
I ² C Bus Status Register (Lower)									
Address : 000082H	7	6	5	4	3	2	1	0	↔ Bit number IBSRL
	BB	RSC	AL	LRB	TRX	AAS	GCA	FBT	
Read/write	⇒ R	⇒ R	⇒ R	⇒ R	⇒ R	⇒ R	⇒ R	⇒ R	
Initial value	⇒ 0	⇒ 0	⇒ 0	⇒ 0	⇒ 0	⇒ 0	⇒ 0	⇒ 0	
I ² C Bus Status Register (Upper)									
Address : 000083H	15	14	13	12	11	10	9	8	↔ Bit number IBSRH
	—	—	PMATCH	WUF	TDR	TCR	MTR	STR	
Read/write	⇒ —	⇒ —	⇒ R	⇒ R/W	⇒ R/W	⇒ R/W	⇒ R/W	⇒ R/W	
Initial value	⇒ —	⇒ —	⇒ 0	⇒ 0	⇒ 0	⇒ 0	⇒ 0	⇒ 0	
I ² C Data Register									
Address : 000084H	7	6	5	4	3	2	1	0	↔ Bit number IDAR
	D7	D6	D5	D4	D3	D2	D1	D0	
Read/write	⇒ R/W	⇒ R/W	⇒ R/W	⇒ R/W	⇒ R/W	⇒ R/W	⇒ R/W	⇒ R/W	
Initial value	⇒ X	⇒ X	⇒ X	⇒ X	⇒ X	⇒ X	⇒ X	⇒ X	

(Continued)

MB90370/375 Series

(Continued)

I²C Address Register

	15	14	13	12	11	10	9	8	↔	Bit number
Address : 000085 _H	—	A6	A5	A4	A3	A2	A1	A0		IADR
Read/write	⇒ —	R/W	R/W	R/W	R/W	R/W	R/W	R/W		
Initial value	⇒ —	X	X	X	X	X	X	X		

I²C Clock Control Register

	7	6	5	4	3	2	1	0	↔	Bit number
Address : 000086 _H	DMBP	—	EN	CS4	CS3	CS2	CS1	CS0		ICCR
Read/write	⇒ R/W	—	R/W	R/W	R/W	R/W	R/W	R/W		
Initial value	⇒ 0	—	0	0	0	0	0	0		

I²C Timeout Control Register

	15	14	13	12	11	10	9	8	↔	Bit number
Address : 000087 _H	—	AAC	—	TOE	EXT	TS2	TS1	TS0		ITCR
Read/write	⇒ —	R/W	—	R/W	R/W	R/W	R/W	R/W		
Initial value	⇒ —	0	—	0	0	0	0	0		

I²C Timeout Clock Register

	7	6	5	4	3	2	1	0	↔	Bit number
Address : 000088 _H	C7	C6	C5	C4	C3	C2	C1	C0		ITOC
Read/write	⇒ R/W	R/W	R/W	R/W	R/W	R/W	R/W	R/W		
Initial value	⇒ 0	0	0	0	0	0	0	0		

I²C Timeout Data Register

	15	14	13	12	11	10	9	8	↔	Bit number
Address : 000089 _H	D7	D6	D5	D4	D3	D2	D1	D0		ITOD
Read/write	⇒ R/W	R/W	R/W	R/W	R/W	R/W	R/W	R/W		
Initial value	⇒ 0	0	0	0	0	0	0	0		

I²C Slave Timeout Register

	7	6	5	4	3	2	1	0	↔	Bit number
Address : 00008A _H	S6	S6	S5	S4	S3	S2	S1	S0		ISTO
Read/write	⇒ R/W	R/W	R/W	R/W	R/W	R/W	R/W	R/W		
Initial value	⇒ 0	0	0	0	0	0	0	0		

I²C Master Timeout Register

	15	14	13	12	11	10	9	8	↔	Bit number
Address : 00008B _H	M7	M6	M5	M4	M3	M2	M1	M0		IMTO
Read/write	⇒ R/W	R/W	R/W	R/W	R/W	R/W	R/W	R/W		
Initial value	⇒ 0	0	0	0	0	0	0	0		

MB90370/375 Series

(2) Block diagram of I²C

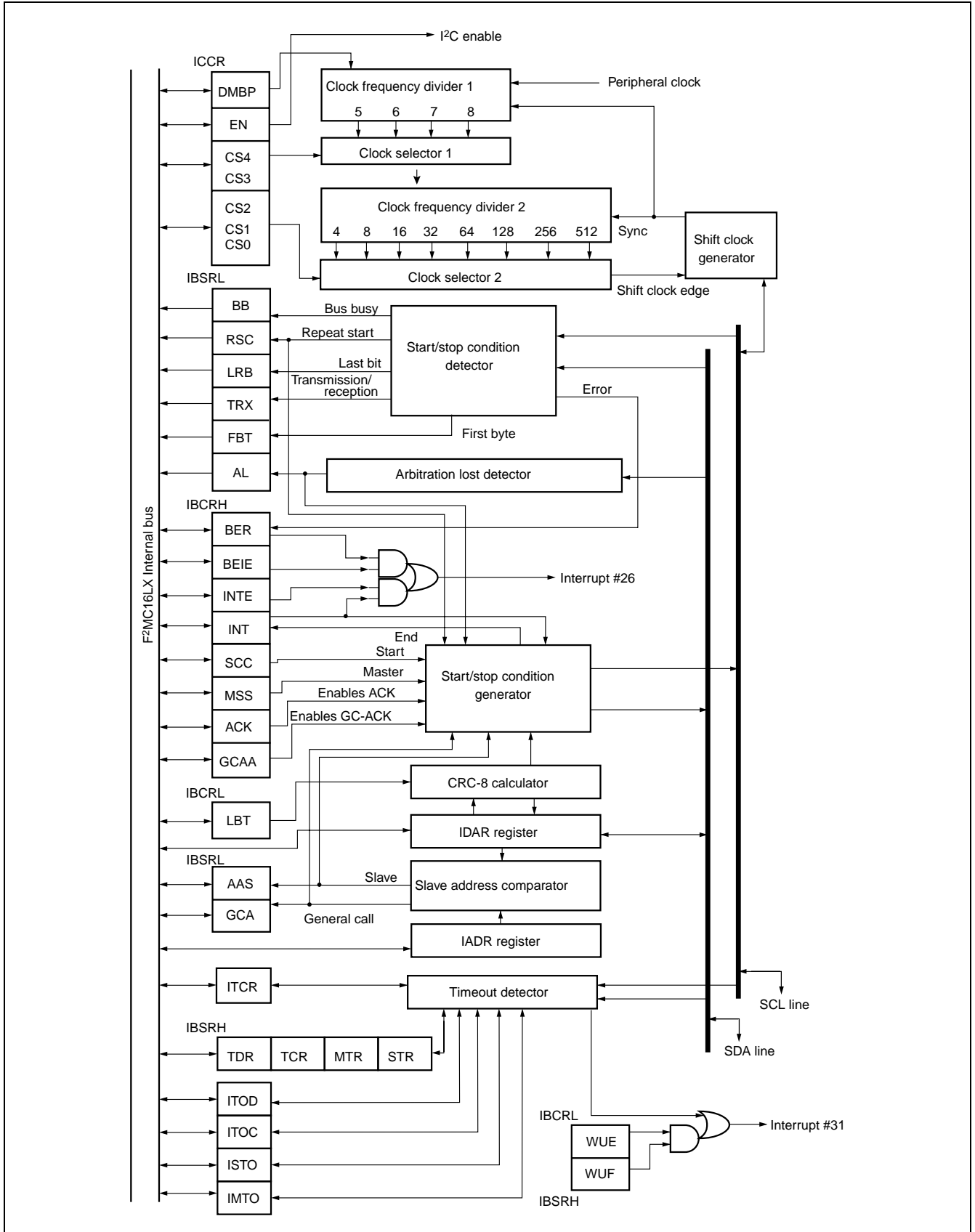

9. I²C

The Multi-address I²C (Inter IC Bus) interface is a simple structure bidirectional bus consisting of two wires : a serial data line (SDA) and a serial clock line (SCL) . Among the devices connected with these two wires, information is transmitted to one another. By recognizing the unique address of each device, it can operate as a transmitting or receiving device in accordance with the function of each device. Among these devices, the master/slave relation is established.

The Multi-address I²C interface can connect two or more devices to the bus provided the upper limit of the bus capacitance does not exceed 400 pF. It is a full-fledged multi-master bus equipped with collision detection and communication adjustment procedures designed to avoid the destruction of data if two or more masters attempt to start data transfer simultaneously. This macro provides 6 addresses to implement the multi-address function.

The communication adjustment procedure permits only one master to control the bus when two or more masters attempt to control the bus so that messages are not lost or the contents of messages are not changed. Multi-master means that multiple masters attempt to control the bus simultaneously without losing messages.

This Multi-address I²C interface includes MCU standby mode wake-up function, and a CRC-8 calculator that performs automatic Packet Error Code (PEC) generation and verification.

(1) Register configuration of I²C

Multi-address I ² C Bus Control Register (Lower)									
Address : 0000C0H	7	6	5	4	3	2	1	0	↔ Bit number
	—	—	—	—	RES	PECE	LBT	WUE	MBCRL
Read/write	⇒ —	⇒ —	⇒ —	⇒ —	⇒ R/W	⇒ R/W	⇒ R/W	⇒ R/W	
Initial value	⇒ —	⇒ —	⇒ —	⇒ —	⇒ 0	⇒ 0	⇒ 0	⇒ 0	
Multi-address I ² C Bus Control Register (Upper)									
Address : 0000C1H	15	14	13	12	11	10	9	8	↔ Bit number
	BER	BEIE	SCC	MSS	ACK	GCAA	INTE	INT	MBCRH
Read/write	⇒ R/W	⇒ R/W	⇒ R/W	⇒ R/W	⇒ R/W	⇒ R/W	⇒ R/W	⇒ R/W	
Initial value	⇒ 0	⇒ 0	⇒ 0	⇒ 0	⇒ 0	⇒ 0	⇒ 0	⇒ 0	
Multi-address I ² C Bus Status Register (Lower)									
Address : 0000C2H	7	6	5	4	3	2	1	0	↔ Bit number
	BB	RSC	AL	LRB	TRX	AAS	GCA	FBT	MBSRL
Read/write	⇒ R	⇒ R	⇒ R	⇒ R	⇒ R	⇒ R	⇒ R	⇒ R	
Initial value	⇒ 0	⇒ 0	⇒ 0	⇒ 0	⇒ 0	⇒ 0	⇒ 0	⇒ 0	
Multi-address I ² C Bus Status Register (Upper)									
Address : 0000C3H	15	14	13	12	11	10	9	8	↔ Bit number
	—	—	PMATCH	WUF	TDR	TCR	MTR	STR	MBSRH
Read/write	⇒ —	⇒ —	⇒ R	⇒ R/W	⇒ R/W	⇒ R/W	⇒ R/W	⇒ R/W	
Initial value	⇒ —	⇒ —	⇒ 0	⇒ 0	⇒ 0	⇒ 0	⇒ 0	⇒ 0	
Multi-address I ² C Data Register									
Address : 0000C4H	7	6	5	4	3	2	1	0	↔ Bit number
	D7	D6	D5	D4	D3	D2	D1	D0	MDAR
Read/write	⇒ R/W	⇒ R/W	⇒ R/W	⇒ R/W	⇒ R/W	⇒ R/W	⇒ R/W	⇒ R/W	
Initial value	⇒ X	⇒ X	⇒ X	⇒ X	⇒ X	⇒ X	⇒ X	⇒ X	

(Continued)

MB90370/375 Series

Multi-address I²C Alert Register

Address : 0000C5 _H	15	14	13	12	11	10	9	8	↔ Bit number MALR
	—	—	—	—	ARAE	ARO	ARF	AEN	
Read/write	↔ —	↔ —	↔ —	↔ —	↔ R/W	↔ R/W	↔ R/W	↔ R/W	
Initial value	↔ —	↔ —	↔ —	↔ —	↔ 0	↔ 0	↔ 0	↔ 0	

Multi-address I²C Address Register 1/3/5

Address ch1 : 0000C6 _H	7	6	5	4	3	2	1	0	↔ Bit number MADR1/3/5
Address ch3 : 0000C8 _H	—	A6	A5	A4	A3	A2	A1	A0	
Address ch5 : 0000CA _H	—	A6	A5	A4	A3	A2	A1	A0	
Read/write	↔ —	↔ R/W	↔ R/W	↔ R/W	↔ R/W	↔ R/W	↔ R/W	↔ R/W	
Initial value	↔ —	↔ X	↔ X	↔ X	↔ X	↔ X	↔ X	↔ X	

Multi-address I²C Address Register 2/4/6

Address ch2 : 0000C7 _H	15	14	13	12	11	10	9	8	↔ Bit number MADR2/4/6
Address ch4 : 0000C9 _H	—	A6	A5	A4	A3	A2	A1	A0	
Address ch6 : 0000CB _H	—	A6	A5	A4	A3	A2	A1	A0	
Read/write	↔ —	↔ R/W	↔ R/W	↔ R/W	↔ R/W	↔ R/W	↔ R/W	↔ R/W	
Initial value	↔ —	↔ X	↔ X	↔ X	↔ X	↔ X	↔ X	↔ X	

Multi-address I²C Clock Control Register

Address : 0000CC _H	7	6	5	4	3	2	1	0	↔ Bit number MCCR
	DMBP	—	EN	CS4	CS3	CS2	CS1	CS0	
Read/write	↔ R/W	↔ —	↔ R/W	↔ R/W	↔ R/W	↔ R/W	↔ R/W	↔ R/W	
Initial value	↔ 0	↔ —	↔ 0	↔ 0	↔ 0	↔ 0	↔ 0	↔ 0	

Multi-address I²C Timeout Control Register

Address : 0000CD _H	15	14	13	12	11	10	9	8	↔ Bit number MTCR
	—	AAC	—	TOE	EXT	TS2	TS1	TS0	
Read/write	↔ —	↔ R/W	↔ —	↔ R/W	↔ R/W	↔ R/W	↔ R/W	↔ R/W	
Initial value	↔ —	↔ 0	↔ —	↔ 0	↔ 0	↔ 0	↔ 0	↔ 0	

Multi-address I²C Timeout Clock Register

Address : 0000CE _H	7	6	5	4	3	2	1	0	↔ Bit number MTOC
	C7	C6	C5	C4	C3	C2	C1	C0	
Read/write	↔ R/W	↔ R/W	↔ R/W	↔ R/W	↔ R/W	↔ R/W	↔ R/W	↔ R/W	
Initial value	↔ 0	↔ 0	↔ 0	↔ 0	↔ 0	↔ 0	↔ 0	↔ 0	

Multi-address I²C Timeout Data Register

Address : 0000CF _H	15	14	13	12	11	10	9	8	↔ Bit number MTOD
	D7	D6	D5	D4	D3	D2	D1	D0	
Read/write	↔ R/W	↔ R/W	↔ R/W	↔ R/W	↔ R/W	↔ R/W	↔ R/W	↔ R/W	
Initial value	↔ 0	↔ 0	↔ 0	↔ 0	↔ 0	↔ 0	↔ 0	↔ 0	

(Continued)

MB90370/375 Series

(Continued)

Multi-address I ² C Slave Timeout Register									Bit number	
Address : 0000D0 _H	7	6	5	4	3	2	1	0	↔	MSTO
	S6	S6	S5	S4	S3	S2	S1	S0		
Read/write	⇒ R/W	R/W	R/W	R/W	R/W	R/W	R/W	R/W		
Initial value	⇒ 0	0	0	0	0	0	0	0		
Multi-address I ² C Master Timeout Register									Bit number	
Address : 0000D1 _H	15	14	13	12	11	10	9	8	↔	MMTO
	M7	M6	M5	M4	M3	M2	M1	M0		
Read/write	⇒ R/W	R/W	R/W	R/W	R/W	R/W	R/W	R/W		
Initial value	⇒ 0	0	0	0	0	0	0	0		

MB90370/375 Series

(2) Block diagram of MI²C

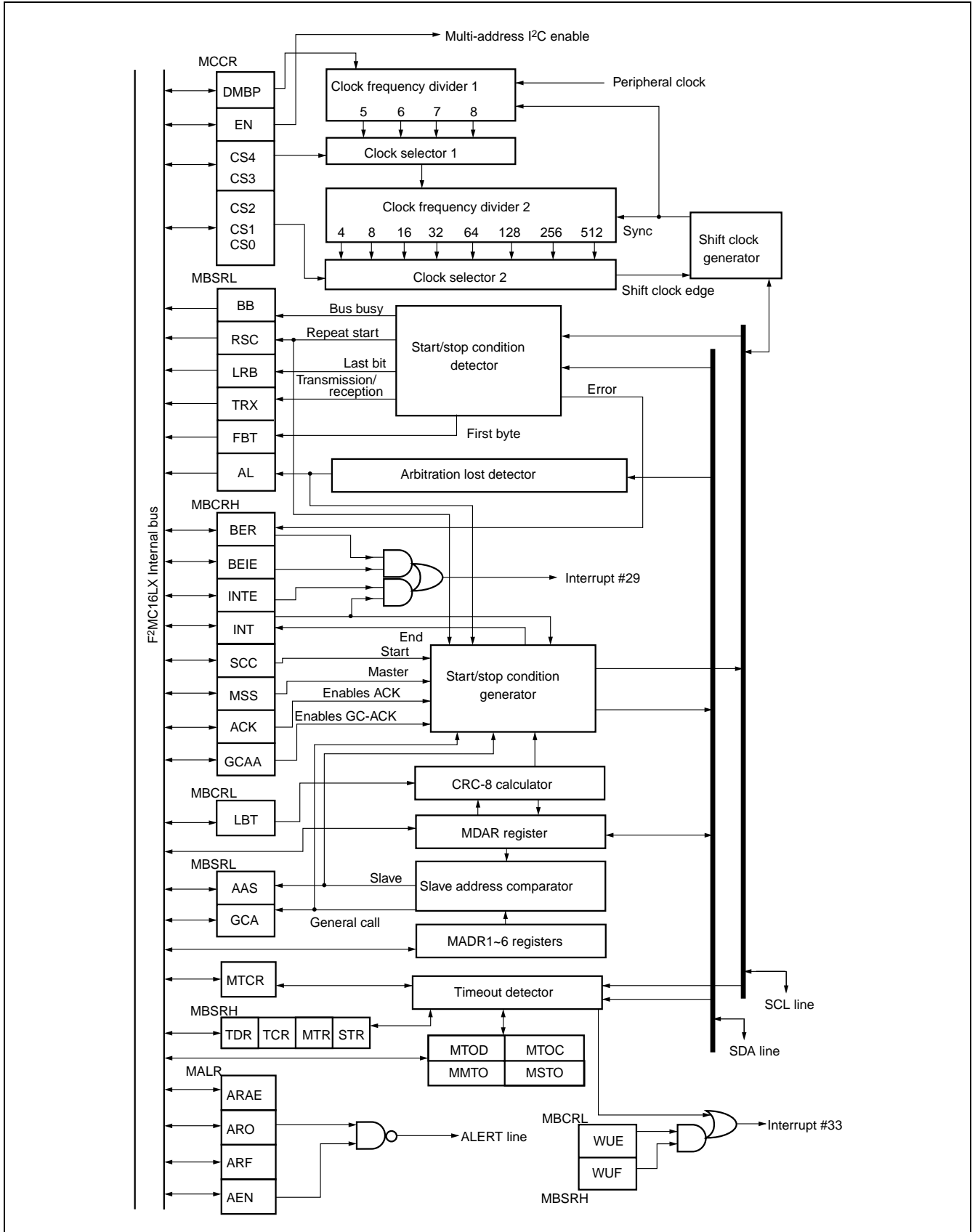

10. Bridge circuit

The bridge circuit can switch the I/O path of each port to I²C or Multi-address I²C.

(1) Register configuration of bridge circuit

Bridge Circuit Selection Register								Bit number	
Address : 00002C _H	7	6	5	4	3	2	1	0	↔ BRSR
	—	—	BM4	BI4	BM3	BI3	BM2	BI2	
Read/write	⇒ —	⇒ —	R/W	R/W	R/W	R/W	R/W	R/W	
Initial value	⇒ —	⇒ —	0	0	0	0	0	0	

(2) Block diagram of bridge circuit

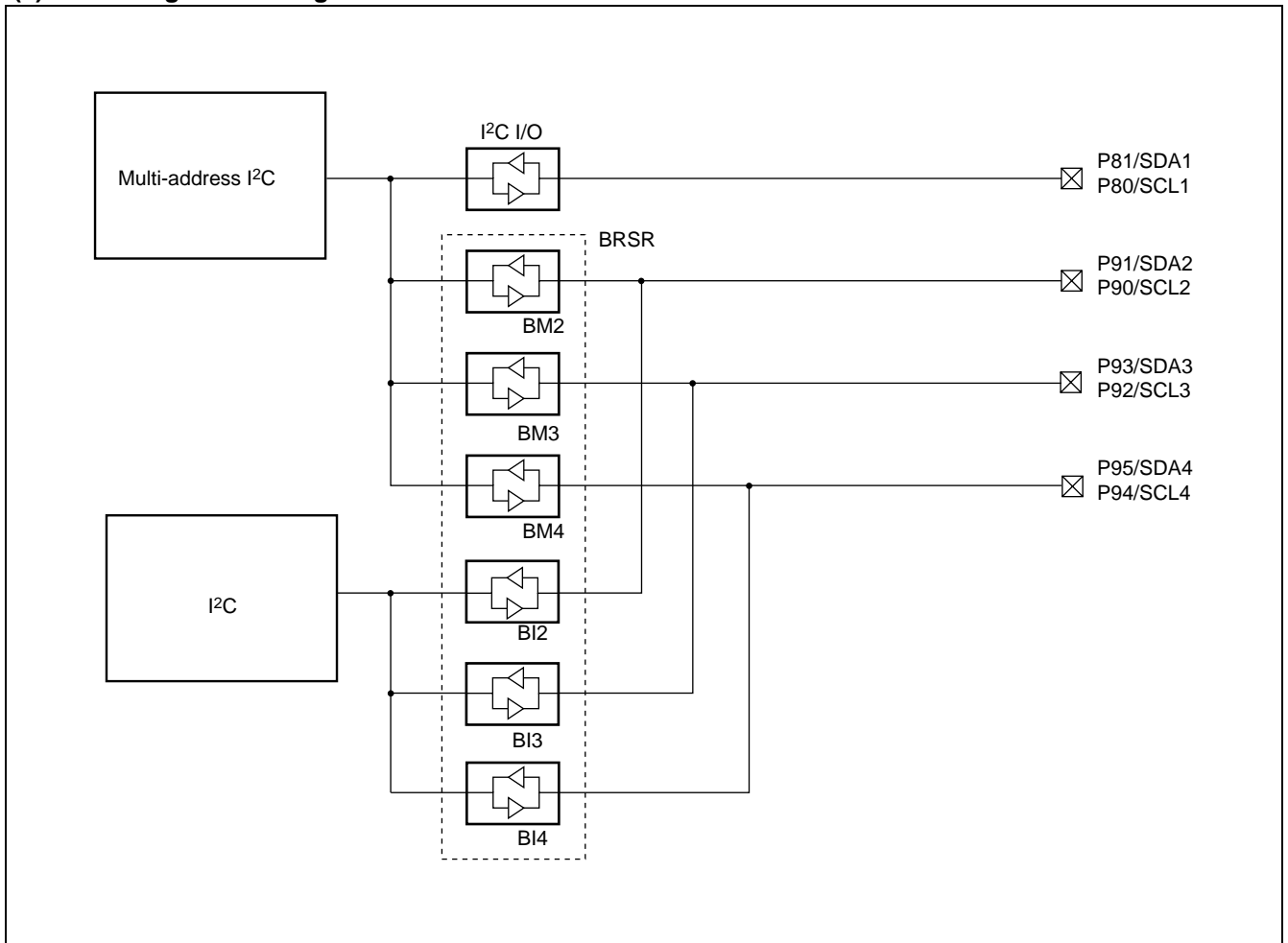

MB90370/375 Series

11. Comparator

This comparator circuit monitors voltage of up to three batteries and automatically controls electric discharge. Either parallel discharge or sequential discharge can be selected.

- Parallel discharge control
In parallel discharge control, all batteries are allowed to discharge when power is not being supplied from the AC adapter.
- If power is being supplied from the AC adapter, the permission/prohibition of discharge for batteries is controlled by software.
- Sequential discharge control
In sequential discharge control, the comparator controls discharge in a specified order, while monitoring intermittent interruption of power, voltage level, and mount/dismount of batteries, when power is not being supplied from the AC adapter.
- If power is being supplied from the AC adapter, the permission/prohibition of discharge for batteries is controlled by software.
- Up to three batteries can be controlled, and the order of discharge can be selected.
- The affect of intermittent interruption of power is automatically filtered.
- Mount/dismount of batteries is automatically detected and discharge is controlled.
- Battery voltage is monitored, and if battery voltage is below the specified voltage, a change over to the next battery is automatically done.

MB90370/375 Series

(1) Register configuration of comparator

Comparator Control Register (Lower)									Bit number COCRL
Address : 0000D8 _H	7	6	5	4	3	2	1	0	
	—	—	BOF3	BOF2	BOF1	SPM2	SPM1	SPM0	
Read/write	⇒ —	⇒ —	⇒ R/W	⇒ R/W	⇒ R/W	⇒ R/W	⇒ R/W	⇒ R/W	
Initial value	⇒ —	⇒ —	⇒ 0	⇒ 0	⇒ 0	⇒ 0	⇒ 0	⇒ 0	
Comparator Control Register (Upper)									Bit number COCRH
Address : 0000D9 _H	15	14	13	12	11	10	9	8	
	SPL3	SPL2	SPL1	B3	B2	B1	DC2	DC1	
Read/write	⇒ R/W	⇒ R/W	⇒ R/W	⇒ R/W	⇒ R/W	⇒ R/W	⇒ R/W	⇒ R/W	
Initial value	⇒ 0	⇒ 0	⇒ 1	⇒ 1	⇒ 1	⇒ 1	⇒ 1	⇒ 1	
Comparator Status Register 1 (Lower)									Bit number COSRL1
Address : 0000DA _H	7	6	5	4	3	2	1	0	
	COR8	COR7	COR6	COR5	COR4	COR3	COR2	COR1	
Read/write	⇒ R/W	⇒ R/W	⇒ R/W	⇒ R/W	⇒ R/W	⇒ R/W	⇒ R/W	⇒ R/W	
Initial value	⇒ 0	⇒ 0	⇒ 0	⇒ 0	⇒ 0	⇒ 0	⇒ 0	⇒ 0	
Comparator Status Register 1 (Upper)									Bit number COSRH1
Address : 0000DB _H	15	14	13	12	11	10	9	8	
	—	—	SWR3	SWR2	SWR1	VAR3	VAR2	VAR1	
Read/write	⇒ —	⇒ —	⇒ R/W	⇒ R/W	⇒ R/W	⇒ R/W	⇒ R/W	⇒ R/W	
Initial value	⇒ —	⇒ —	⇒ 0	⇒ 0	⇒ 0	⇒ 0	⇒ 0	⇒ 0	
Comparator Interrupt Control Register (Lower)									Bit number CICRL
Address : 0000DC _H	7	6	5	4	3	2	1	0	
	CEN8	CEN7	CEN6	CEN5	CEN4	CEN3	CEN2	CEN1	
Read/write	⇒ R/W	⇒ R/W	⇒ R/W	⇒ R/W	⇒ R/W	⇒ R/W	⇒ R/W	⇒ R/W	
Initial value	⇒ 0	⇒ 0	⇒ 0	⇒ 0	⇒ 0	⇒ 0	⇒ 0	⇒ 0	

(Continued)

MB90370/375 Series

(Continued)

Comparator Interrupt Control Register (Upper)										
Address : 0000DD _H	15	14	13	12	11	10	9	8	↔	Bit number CICRH
	—	—	SEN3	SEN2	SEN1	VEN3	VEN2	VEN1		
Read/write	⇒	—	R/W	R/W	R/W	R/W	R/W	R/W		
Initial value	⇒	—	0	0	0	0	0	0		
Comparator Status Register 2 (Lower)										
Address : 0000DE _H	7	6	5	4	3	2	1	0	↔	Bit number COSRL2
	COS8	COS7	COS6	COS5	COS4	COS3	COS2	COS1		
Read/write	⇒	R	R	R	R	R	R	R		
Initial value	⇒	X	X	X	X	X	X	X		
Comparator Status Register 2 (Upper)										
Address : 0000DF _H	15	14	13	12	11	10	9	8	↔	Bit number COSRH2
	—	—	SWS3	SWS2	SWS1	VAL3	VAL2	VAL1		
Read/write	⇒	—	R	R	R	R	R	R		
Initial value	⇒	—	X	X	X	X	X	X		
Comparator Input Enable Register										
Address : 0000E0 _H	7	6	5	4	3	2	1	0	↔	Bit number CIER
	—	—	—	BIE3	BIE2	BIE1	DIE2	DIE1		
Read/write	⇒	—	—	R/W	R/W	R/W	R/W	R/W		
Initial value	⇒	—	—	1	1	1	1	1		

(2) Block diagram of comparator

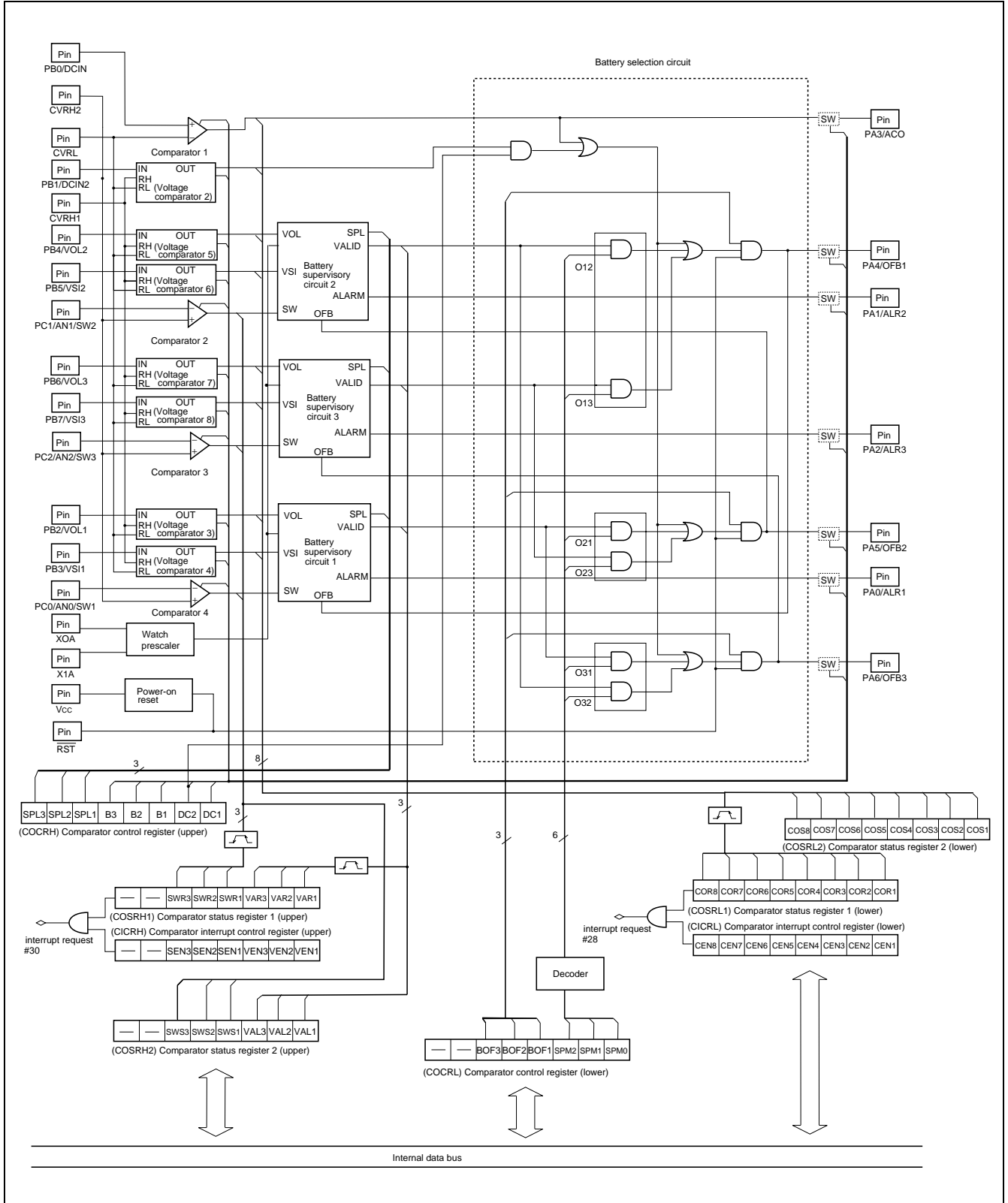

MB90370/375 Series

12. UART (× 3)

The UART (Universal Asynchronous Receiver Transmitter) is a serial I/O port for asynchronous (start-stop) communication or clock-synchronous communication.

The UART has the following features :

- Full-duplex double buffering
- Capable of asynchronous (start-stop bit) and CLK-synchronous communications
- Support for the multiprocessor mode
- Various method of baud rate generation :
 - External clock input possible
 - Internal clock (a clock supplied from 16-bit reload timer can be used)
 - Embedded dedicated baud rate generator

Operation	Baud rate
Asynchronous	76923 / 38461 / 19230 / 9615 / 500K / 250K bps
CLK synchronous	16M / 8M / 4M / 2M / 1M / 500K bps

- Error detection functions (parity, framing, overrun)
- NRZ (Non Return to Zero) signal format
- Interrupt request :
 - Receive interrupt (receive complete, receive error detection)
 - Transmit interrupt (transmission complete)
 - Transmit / receive conforms to extended intelligent I/O service (EI²OS)

(1) Register configuration of UART

Serial Mode Register

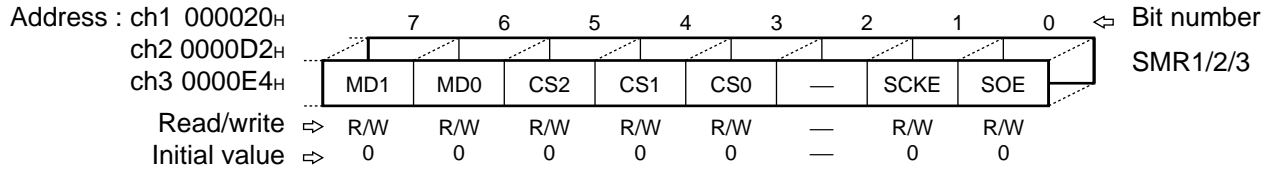

Serial Control Register

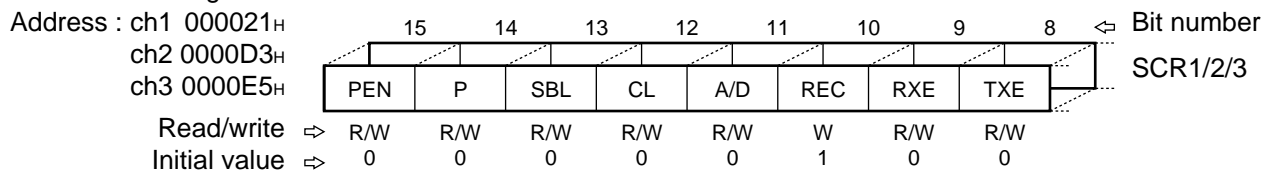

UART Input Data Register / Output Data Register

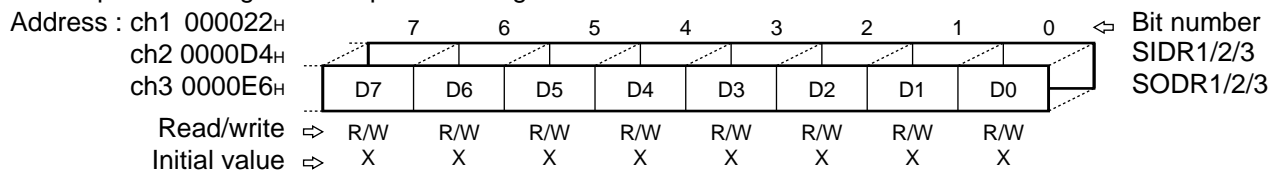

UART Status Register

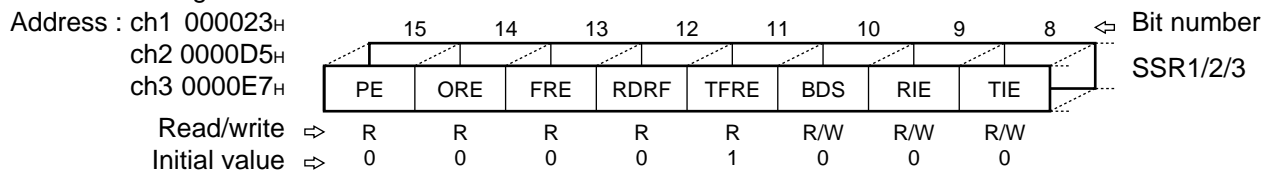

Clock Division Control Register

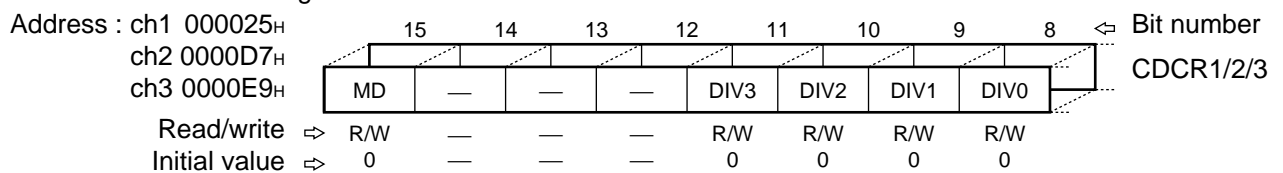

Mode 2 Control Register

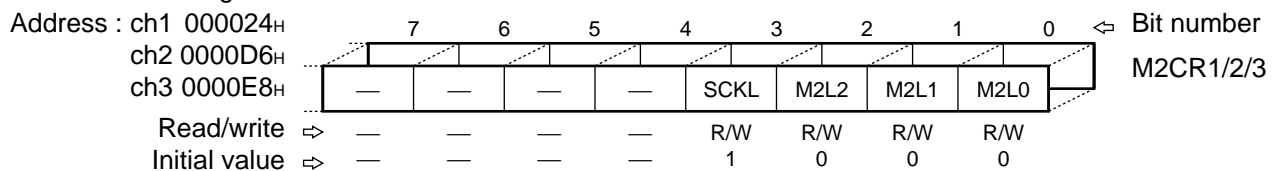

MB90370/375 Series

(2) Block diagram of UART

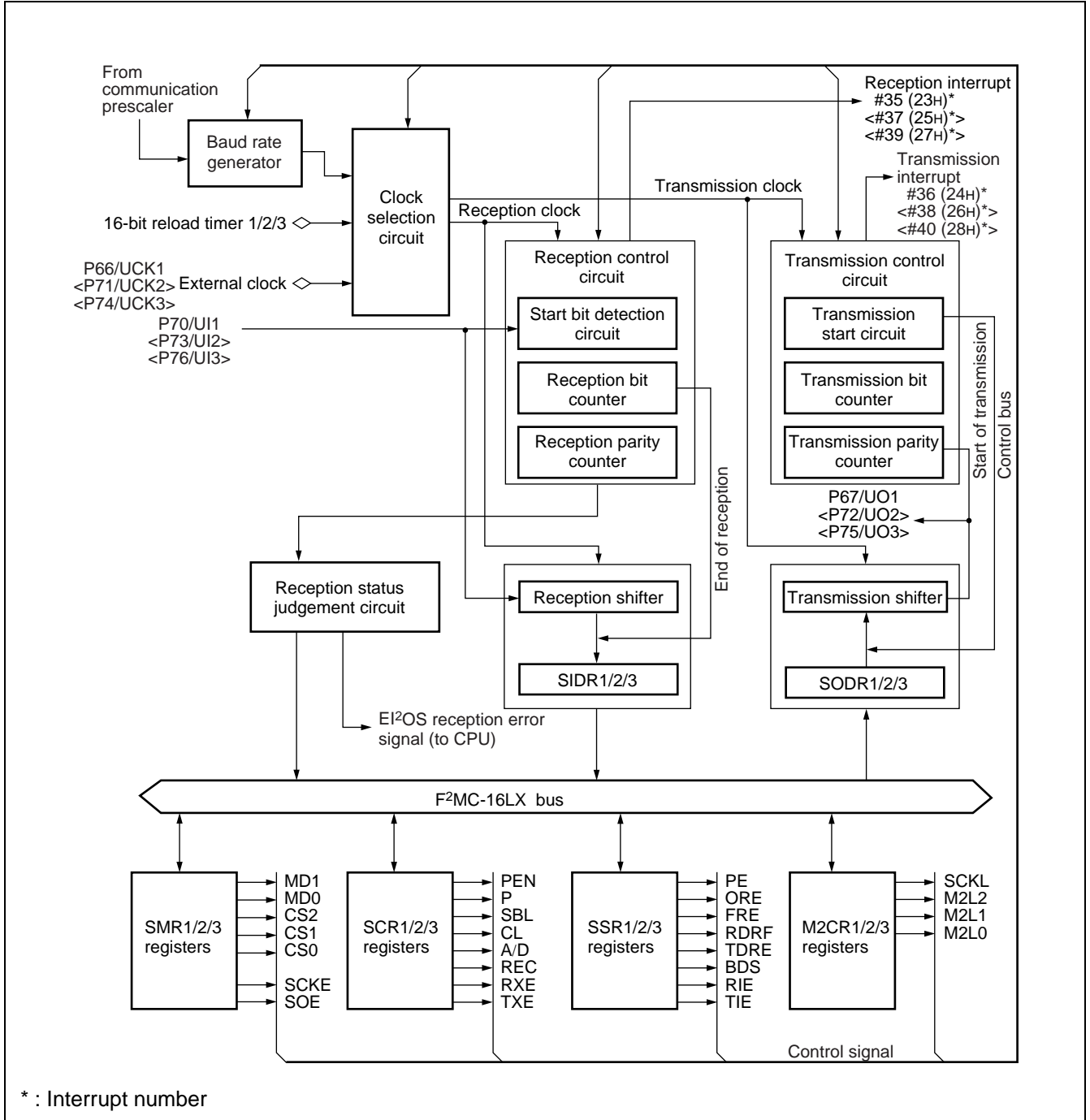

MB90370/375 Series

13. LCD controller/driver (not for MB90F377)

The LCD (Liquid Crystal Display) controller/driver function displays the contents of a display data memory directly to the LCD panel by segment and common outputs.

- Up to nine segment outputs (SEG0 to SEG8) and four common outputs (COM0 to COM3) may be used.
- Built-in display RAM.
- Three selectable duty ratios (1/2, 1/3, and 1/4) . However, not all duty ratios are available with all bias settings.
- Either the main or sub-clock can be selected as the drive clock.
- LCD can be driven directly.

Table below shows the duty ratios available with each bias setting.

Part number	Bias	1/2 duty ratio	1/3 duty ratio	1/4 duty ratio
MB90370 series	1/2 bias	○	X	X
	1/3 bias	X	○	○

○ : Recommended mode

X : Do not use

(1) Register configuration of LCD

LCDC Control Register (Upper)									
Address : 0000EF _H	15	14	13	12	11	10	9	8	↔ Bit number LCRH
	SS4	VS	CS1	CS0	SS3	SS2	SS1	SS0	
Read/write	⇒ R/W	R/W	R/W	R/W	R/W	R/W	R/W	R/W	
Initial value	⇒ 0	0	0	0	0	0	0	0	
LCDC Control Register (Lower)									
Address : 0000EE _H	7	6	5	4	3	2	1	0	↔ Bit number LCRL
	CSS	LCEN	VSEL	BK	MS1	MS0	FP1	FP0	
Read/write	⇒ R/W	R/W	R/W	R/W	R/W	R/W	R/W	R/W	
Initial value	⇒ 0	0	0	1	0	0	0	0	

MB90370/375 Series

(2) Block diagram of LCD

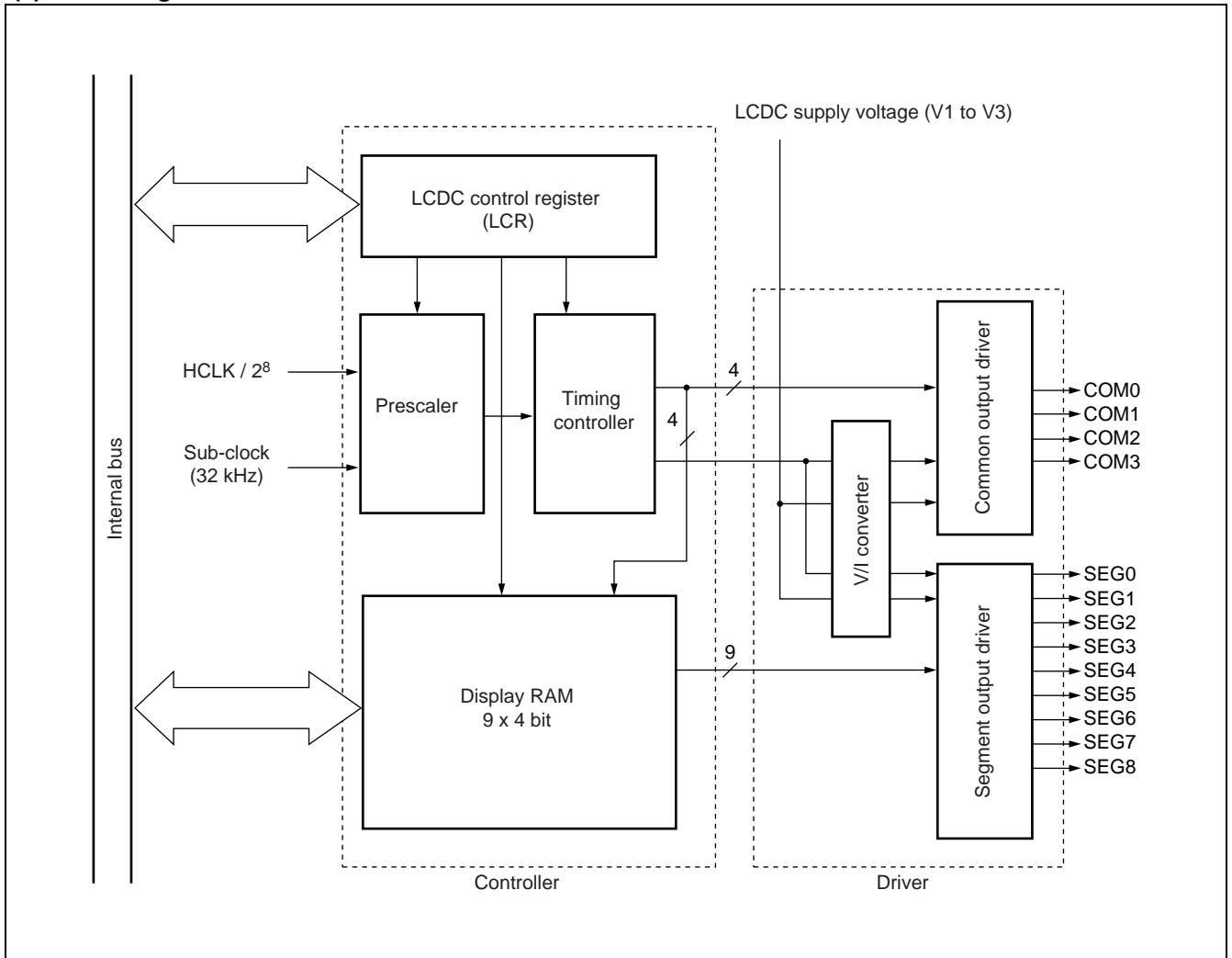

14. A/D converter

The A/D (Analog to Digital) converter converts the analog voltage input to an analog input pin (input voltage) to a digital value.

The converter has the following features :

- The minimum conversion time is 6.13 μ s (for a machine clock of 16 MHz; includes the sampling time) .
- The minimum sampling time is 3.75 μ s (for a machine clock of 16 MHz) .
- The converter uses the RC-type successive approximation conversion method with a sample and hold circuit.
- A resolution of 10 bits or 8 bits can be selected.
- Up to twelve channels for analog input pins can be selected by a program.
- Various conversion modes :
 - Single conversion mode : Selectively convert one channel.
 - Scan conversion mode : Continuously convert multiple channels. Maximum of 12 selectable channels.
 - Continuous conversion mode : Repeatedly convert specified channels.
 - Stop conversion mode : Convert one channel then halt until the next activation. (Enables synchronization of the conversion start timing.)
- At the end of A/D conversion, an interrupt request can be generated and EI²OS can be activated.
- In the interrupt-enabled state, the conversion data protection function prevents any part of the data from being lost through continuous conversion.
- The conversion can be activated by software, 16-bit reload timer 4 (rise edge) and ADTG.

(1) Register configuration of A/D converter

Analog Input Enable Register 2									
Address : 00002B _H	15	14	13	12	11	10	9	8	⇐ Bit number
	—	—	—	—	ADE11	ADE10	ADE9	ADE8	ADER2
Read/write	⇐ —	⇐ —	⇐ —	⇐ —	R/W	R/W	R/W	R/W	
Initial value	⇐ —	⇐ —	⇐ —	⇐ —	1	1	1	1	
Analog Input Enable Register 1									
Address : 00002A _H	7	6	5	4	3	2	1	0	⇐ Bit number
	ADE7	ADE6	ADE5	ADE4	ADE3	ADE2	ADE1	ADE0	ADER1
Read/write	⇐ R/W	⇐ R/W	⇐ R/W	⇐ R/W	⇐ R/W	⇐ R/W	⇐ R/W	⇐ R/W	
Initial value	⇐ 1	⇐ 1	⇐ 1	⇐ 1	⇐ 1	⇐ 1	⇐ 1	⇐ 1	
A/D Control Status Register 1									
Address : 000031 _H	15	14	13	12	11	10	9	8	⇐ Bit number
	BUSY	INT	INTE	PAUS	STS1	STS0	STRT	RESV	ADCS1
Read/write	⇐ R/W	⇐ R/W	⇐ R/W	⇐ R/W	⇐ R/W	⇐ R/W	⇐ W	⇐ R/W	
Initial value	⇐ 0	⇐ 0	⇐ 0	⇐ 0	⇐ 0	⇐ 0	⇐ 0	⇐ 0	
A/D Control Status Register 0									
Address : 000030 _H	7	6	5	4	3	2	1	0	⇐ Bit number
	MD1	MD0	—	—	—	—	—	—	ADCS0
Read/write	⇐ R/W	⇐ R/W	⇐ —	⇐ —	⇐ —	⇐ —	⇐ —	⇐ —	
Initial value	⇐ 0	⇐ 0	⇐ —	⇐ —	⇐ —	⇐ —	⇐ —	⇐ —	

(Continued)

MB90370/375 Series

(Continued)

A/D Control Register										
Address : 00002D _H	15	14	13	12	11	10	9	8	↔	Bit number ADC0
	ANS3	ANS2	ANS1	ANS0	ANE3	ANE2	ANE1	ANE0		
Read/write	⇒ R/W	⇒ R/W	⇒ R/W	⇒ R/W	⇒ R/W	⇒ R/W	⇒ R/W	⇒ R/W		
Initial value	⇒ 0	⇒ 0	⇒ 0	⇒ 0	⇒ 0	⇒ 0	⇒ 0	⇒ 0		
A/D Data Register (Upper)										
Address : 00002F _H	15	14	13	12	11	10	9	8	↔	Bit number ADCR1
	S10	ST1	ST0	CT1	CT0	—	D9	D8		
Read/write	⇒ R/W	⇒ W	⇒ W	⇒ W	⇒ W	⇒ —	⇒ R	⇒ R		
Initial value	⇒ 0	⇒ 0	⇒ 0	⇒ 0	⇒ 0	⇒ —	⇒ X	⇒ X		
A/D Data Register (Lower)										
Address : 00002E _H	7	6	5	4	3	2	1	0	↔	Bit number ADCR0
	D7	D6	D5	D4	D3	D2	D1	D0		
Read/write	⇒ R	⇒ R	⇒ R	⇒ R	⇒ R	⇒ R	⇒ R	⇒ R		
Initial value	⇒ X	⇒ X	⇒ X	⇒ X	⇒ X	⇒ X	⇒ X	⇒ X		

(2) Block diagram of A/D converter

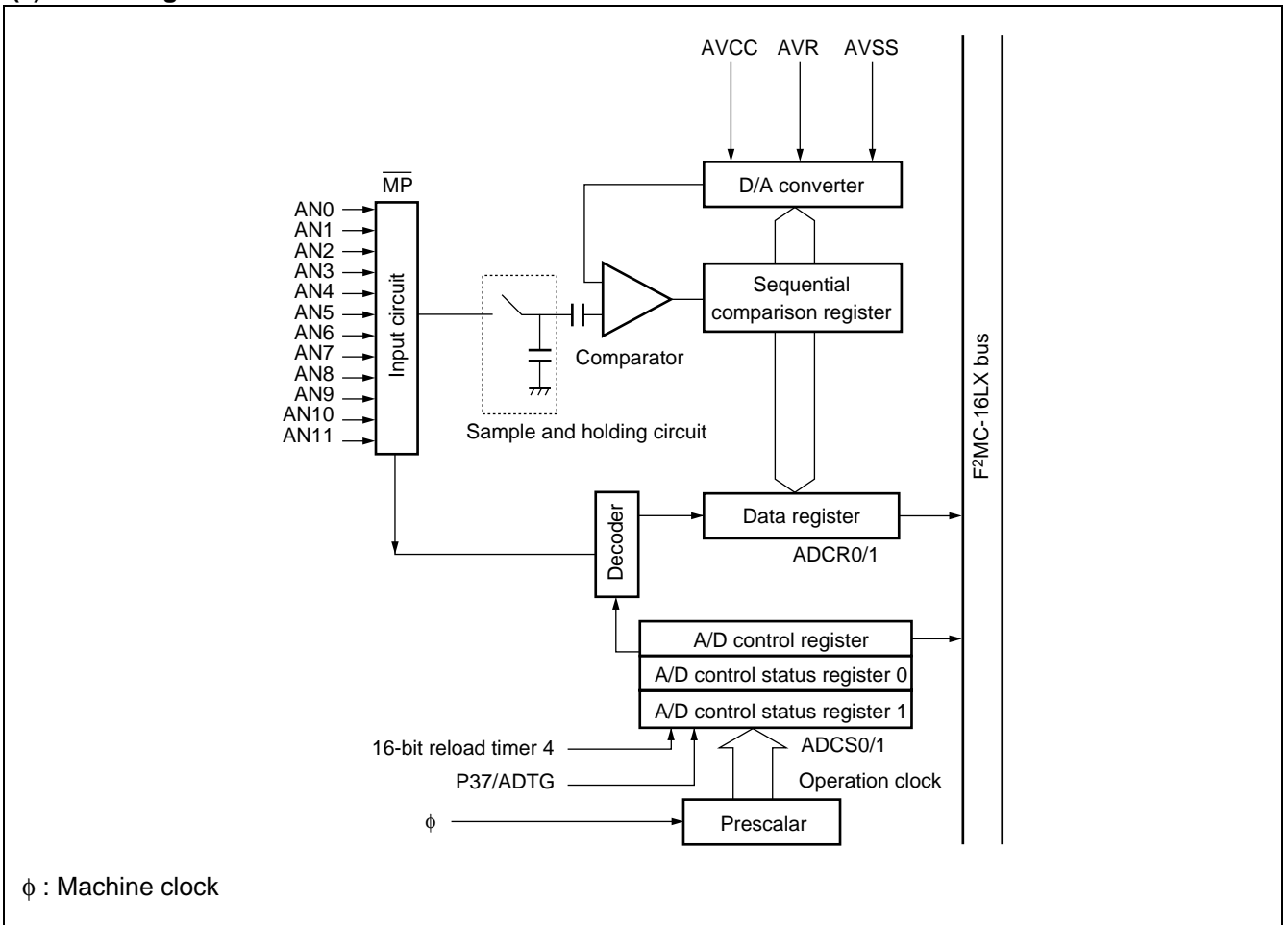

15. D/A converter

The D/A (Digital to Analog) converter is used to generate an analog output from an 8-bit digital input. By setting the enable bit in the D/A control register (DACR) to 1, it will enable the corresponding D/A output channel. Hence, setting this bit to 0 will disable that channel.

If D/A output is disabled, the analog switch inserted to the output of each D/A converter channel in series is turned off. In the D/A converter, the bit is cleared to 0 and the direct-current path is shut off. The above is also true in the stop mode.

The output voltage of the D/A converter ranges from 0 V to $255/256 \times AV_{CC}$.

The D/A converter output does not have the internal buffer amplifier. The analog switch (= 100 Ω) is inserted to the output in series. To apply load to the output externally, estimate a sufficient stabilization time.

Table below lists the theoretical values of output voltage of the D/A converter.

Value written to DA07 to DA00 and DA17 to DA10	Theoretical value of output voltage
00 _H	$0/256 \times AV_{CC}$ (= 0 V)
01 _H	$1/256 \times AV_{CC}$
02 _H	$2/256 \times AV_{CC}$
:	:
FD _H	$253/256 \times AV_{CC}$
FE _H	$254/256 \times AV_{CC}$
FF _H	$255/256 \times AV_{CC}$

MB90370/375 Series

(1) Register configuration of D/A converter

D/A converter register 1								Bit number	
Address : 00005B _H	15	14	13	12	11	10	9	8	DAT1
	DA17	DA16	DA15	DA14	DA13	DA12	DA11	DA10	
Read/write	⇒ R/W	R/W	R/W	R/W	R/W	R/W	R/W	R/W	
Initial value	⇒ X	X	X	X	X	X	X	X	
D/A converter register 0								Bit number	
Address : 00005A _H	7	6	5	4	3	2	1	0	DAT0
	DA07	DA06	DA05	DA04	DA03	DA02	DA01	DA00	
Read/write	⇒ R/W	R/W	R/W	R/W	R/W	R/W	R/W	R/W	
Initial value	⇒ X	X	X	X	X	X	X	X	
D/A control register 1								Bit number	
Address : 00005D _H	15	14	13	12	11	10	9	8	DACR1
	—	—	—	—	—	—	—	DAE1	
Read/write	⇒ —	—	—	—	—	—	—	R/W	
Initial value	⇒ —	—	—	—	—	—	—	0	
D/A control register 0								Bit number	
Address : 00005C _H	7	6	5	4	3	2	1	0	DACR0
	—	—	—	—	—	—	—	DAE0	
Read/write	⇒ —	—	—	—	—	—	—	R/W	
Initial value	⇒ —	—	—	—	—	—	—	0	

MB90370/375 Series

(2) Block diagram of D/A converter

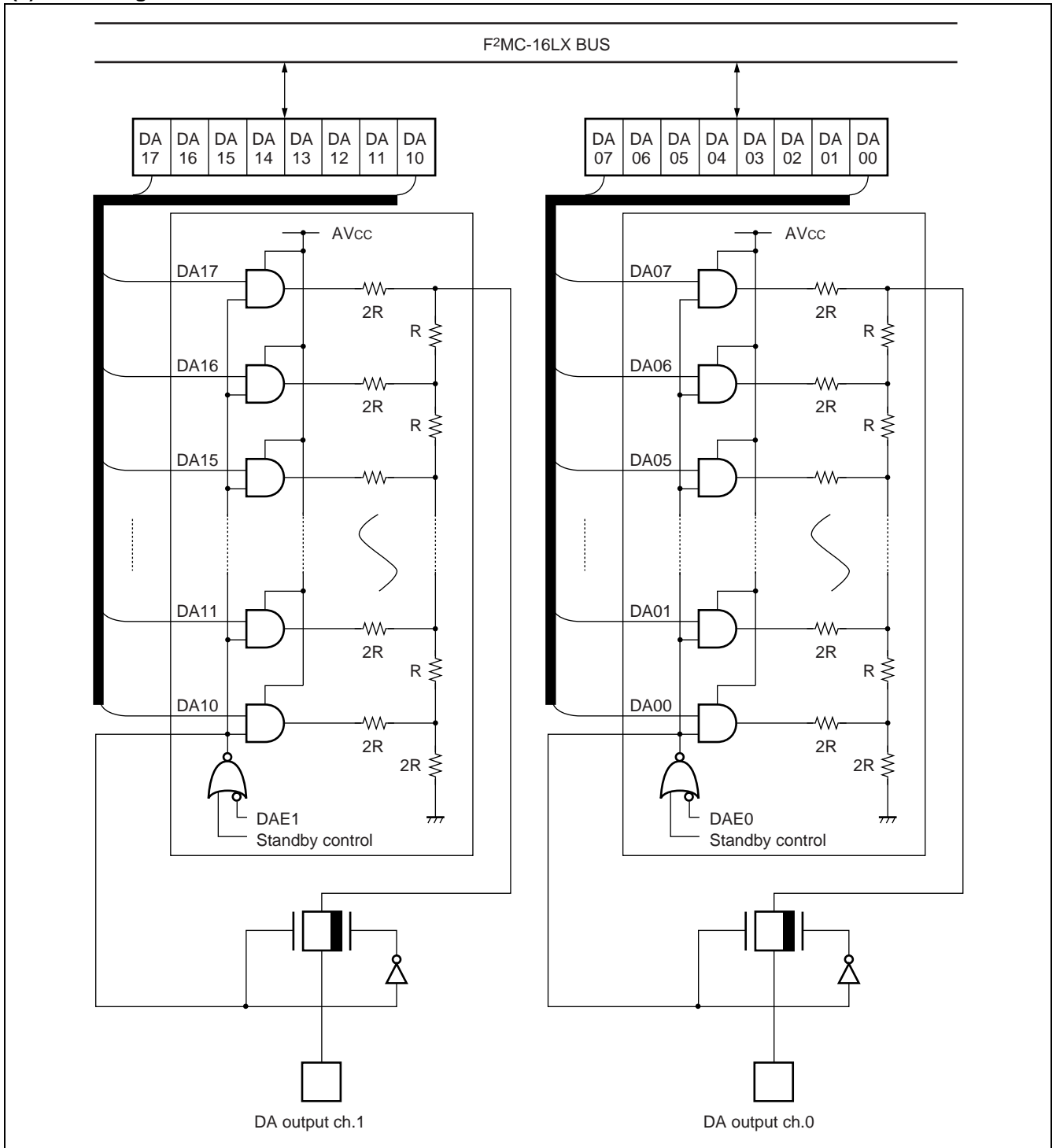

MB90370/375 Series

16. LPC interface

The LPC (Low Pin Count) interface consists of an LPC bus interface, universal parallel interface (UPI × 4 channels) , gate address A20 function and LPC data buffer array. By using the LPC bus interface and UPI, data can be exchanged with an external host CPU synchronously via an external LPC bus.

- LPC bus interface

The LPC bus interface provides direct access of host CPU to UPI.

- It supports I/O read and I/O write cycle only. Other cycle types will be ignored.
- It supports LPC clock running at 33 MHz.

- Universal parallel interface, UPI × 4 channels

The UPI is used to exchange parallel data to serial data in LPC bus with host CPU.

- An 8-bit data will be transmitted or received.
- A buffer function is available for independent input and output.
- The I/O buffer status can be output externally through LPC bus interface.

- Gate address A20 function for UPI channel 0

The GA20 (Gate Address A20) is intended to implement the memory management in a PC architecture. This allows the access to the extended memory needed by the operating system. On-chip logic is provided to speed up the generation of GA20.

- Data buffer array

The data buffer array is consisted of 32 bytes UP data register and 16 bytes DOWN data register to speed up the data transfer between MCU and external host through LPC bus.

(1) Register configuration of LPC bus interface register

LPC Control Register									Bit number LCR
Address : 00006EH	7	6	5	4	3	2	1	0	
	—	—	—	—	—	LRF	LRIE	LPE	↔
Read/write	⇒	—	—	—	—	R/W	R/W	R/W	
Initial value	⇒	—	—	—	—	0	0	0	

(2) Register configuration of UPI registers

UPI Address Register (Upper)

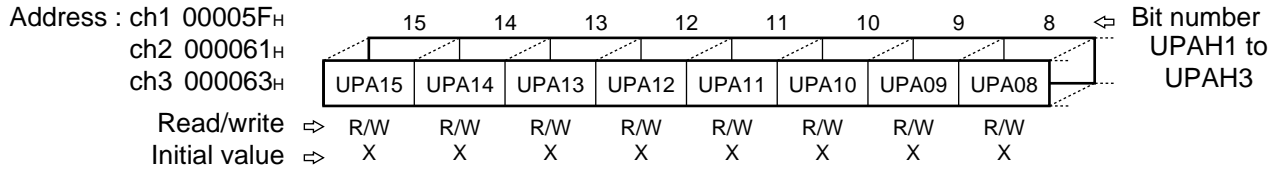

UPI Address Register (Lower)

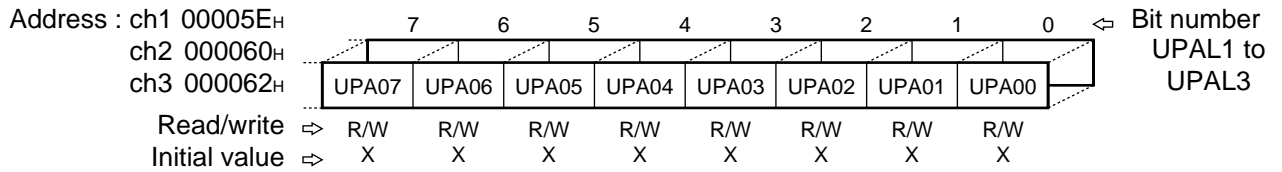

UPI Control Register (Upper)

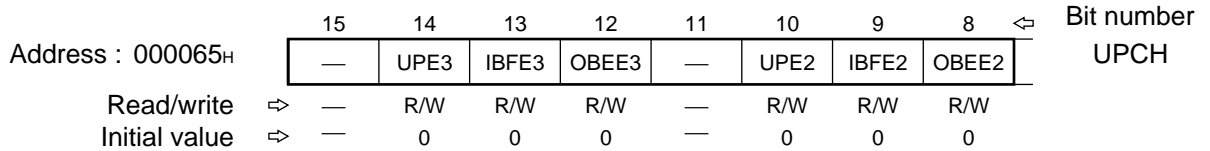

UPI Control Register (Lower)

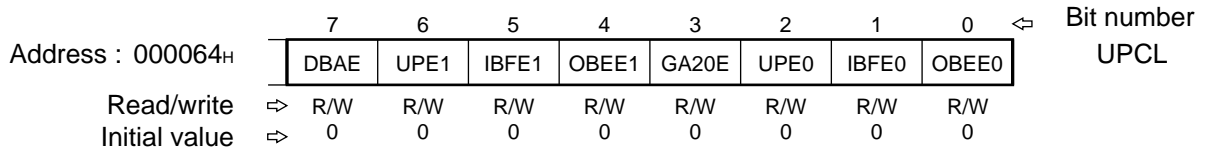

UPI Status Register

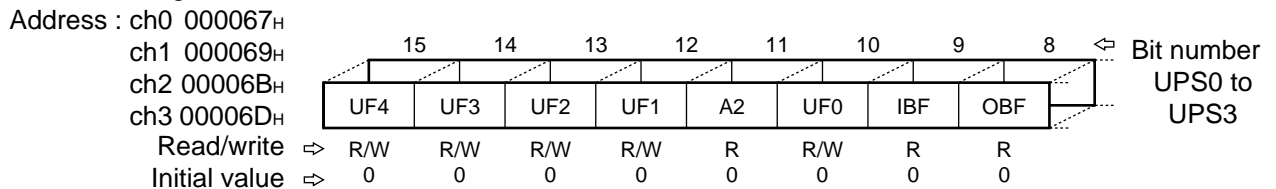

UPI Data Input Register / Data Output Register

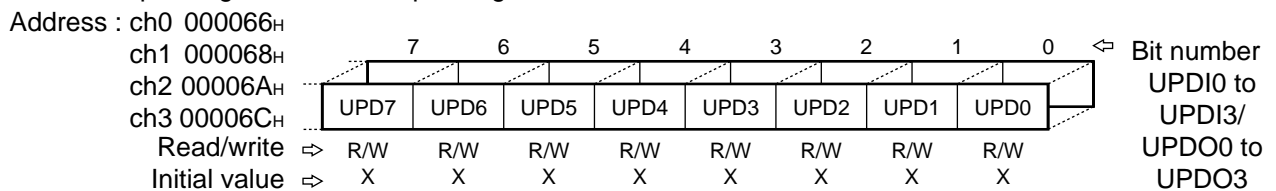

MB90370/375 Series

(3) Register configuration of LPC data buffer registers

Data Buffer Array Address Register (Upper)

Address : 003FF1 _H	15	14	13	12	11	10	9	8	⇐ Bit number DBAAH
	DA15	DA14	DA13	DA12	DA11	DA10	DA09	DA08	
Read/write	⇐ R/W	R/W	R/W	R/W	R/W	R/W	R/W	R/W	
Initial value	⇐ X	X	X	X	X	X	X	X	

Data Buffer Array Address Register (Lower)

Address : 003FF0 _H	7	6	5	4	3	2	1	0	⇐ Bit number DBAAL
	DA07	DA06	DA05	DA04	DA03	DA02	DA01	DA00	
Read/write	⇐ R/W	R/W	R/W	R/W	R/W	R/W	R/W	R/W	
Initial value	⇐ X	X	X	X	X	X	X	X	

UP Data Register (upper)

Address : ch0 003FC1 _H ch1 003FC3 _H to chF 003FDF _H	15	14	13	12	11	10	9	8	⇐ Bit number UDRH0 to UDRHF
	UP15	UP14	UP13	UP12	UP11	UP10	UP09	UP08	
Read/write	⇐ R/W	R/W	R/W	R/W	R/W	R/W	R/W	R/W	
Initial value	⇐ X	X	X	X	X	X	X	X	

UP Data Register (lower)

Address : ch0 003FC0 _H ch1 003FC2 _H to chF 003FDE _H	7	6	5	4	3	2	1	0	⇐ Bit number UDRL0 to UDRLF
	UP07	UP06	UP05	UP04	UP03	UP02	UP01	UP00	
Read/write	⇐ R/W	R/W	R/W	R/W	R/W	R/W	R/W	R/W	
Initial value	⇐ X	X	X	X	X	X	X	X	

DOWN Data Register (upper)

Address : ch0 003FE1 _H ch1 003FE3 _H to ch7 003FEF _H	15	14	13	12	11	10	9	8	⇐ Bit number DNDH0 to DNDH7
	DN15	DN14	DN13	DN12	DN11	DN10	DN09	DN08	
Read/write	⇐ R	R	R	R	R	R	R	R	
Initial value	⇐ X	X	X	X	X	X	X	X	

DOWN Data Register (lower)

Address : ch0 003FE0 _H ch1 003FE2 _H to ch7 003FEE _H	7	6	5	4	3	2	1	0	⇐ Bit number DNDL0 to DNDL7
	DN07	DN06	DN05	DN04	DN03	DN02	DN01	DN00	
Read/write	⇐ R	R	R	R	R	R	R	R	
Initial value	⇐ X	X	X	X	X	X	X	X	

(Continued)

MB90370/375 Series

(Continued)

Index Register		7	6	5	4	3	2	1	0	↔	Bit number
Address :	—	—	—	IX05	IX04	IX03	IX02	IX01	IX00		IXR
Read/write	⇒	—	—	R/W	R/W	R/W	R/W	R/W	R/W		
Initial value	⇒	—	—	0	0	0	0	0	0		

Data Port Register		7	6	5	4	3	2	1	0	↔	Bit number
Address :	—	DP07	DP06	DP05	DP04	DP03	DP02	DP01	DP00		DPR
Read/write	⇒	R/W	R/W	R/W	R/W	R/W	R/W	R/W	R/W		
Initial value	⇒	X	X	X	X	X	X	X	X		

(4) Block diagram of LPC interface

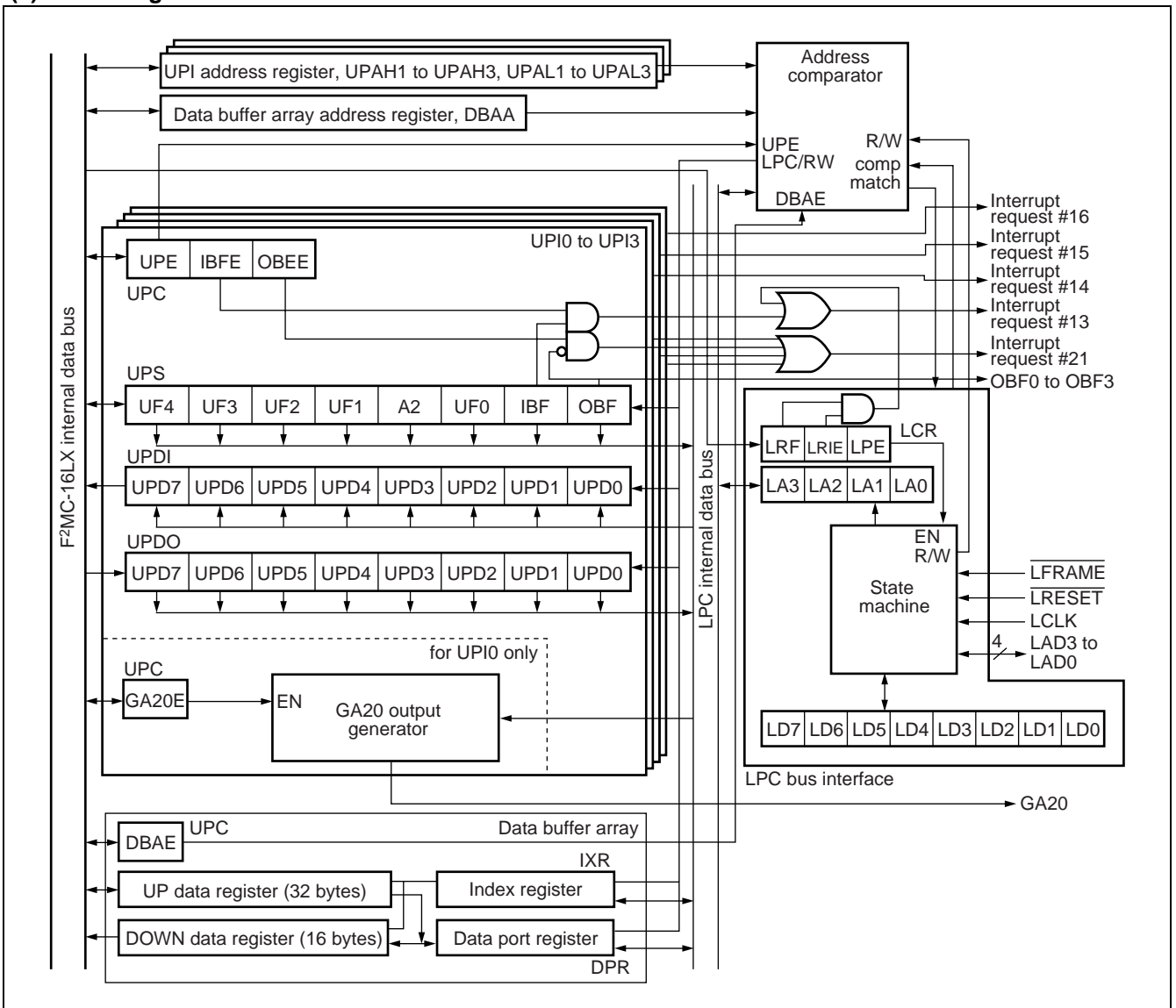

MB90370/375 Series

17. Serial IRQ controller

The serial IRQ controller consists of a 6-channel serial IRQ control circuit and an LPC clock monitor / control circuit. By using this serial IRQ controller, host interrupt requests can be transferred serially through a single signal wire (SERIRQ) , synchronized with the LPC clock.

6-channel serial IRQ control circuit

- The 6-channel serial IRQ control circuit consists of a serial interrupt control register (SICR) , 4 serial interrupt frame number registers (SIFR1 to SIFR4) , a protocol state machine and a serial interrupt data latch and output control.
- For channel 0A, 0B and 1 to 3, if SICR : OBE bit (OBF controlled enable bit) = 0, then serial IRQ can be controlled by software setting of SICR : IRR bit. If SICR : OBE bit = 1, then software control is disabled and serial IRQ is controlled by OBF flag (Output buffer full flag) from LPC UPI0 to UPI3.
- For channel 4, serial IRQ can be controlled by software setting of SICR : IRR bit.
- For channel 0A and 0B, additional enable bit (SICR : EN0A/0B bit) can be used to latch and keep the OBF0 or IRR0A/0B bit status.
- The serial interrupt data latch transfers serial IRQs serially according to their frame number. The frame number for channel 0A is fixed to "IRQ1", for channel 0B is fixed to "IRQ12", and the frame number for channel 1 to channel 4 are software programmable (IRQ1 to IRQ15, and IRQ21 to IRQ31) by setting the SIFR1 to SIFR4.
- By monitoring the SERIRQ and the LPC clock pin, the protocol state machine can detect the START frame condition. Then it starts counting the DATA frame and transfers its serial IRQs through SERIRQ. Finally it can switch to continuous/quiet mode operation by determine the STOP frame condition.
- The serial interrupt output control support both continuous and quiet mode operation. In continuous mode operation, only the host can initiate the serial IRQs transfer; In quiet mode operation, both the host and slave (e.g. the serial IRQ controller) can initiate the serial IRQs transfer.

LPC clock monitor / control circuit

- The LPC clock monitor / control circuit consists of a clock-run monitor / control circuit. By monitoring the clock-run pin ($\overline{\text{CLKRUN}}$) , the clock monitor / control circuit can determine whether the host has stopped LPC clock in quiet mode operation or not. If LPC clock is stopped and the controller wants to initiate the serial IRQs transfer, then it can request the host to restart the LPC clock by controlling the $\overline{\text{CLKRUN}}$ pin.

MB90370/375 Series

(1) Register configuration of serial IRQ controller

Serial Interrupt Control Register (Lower)

Address : 000032 _H	7	6	5	4	3	2	1	0	↔	Bit number SICRL
	EN0B	EN0A	IRR4	IRR3	IRR2	IRR1	IRR0B	IRR0A		
Read/write	⇒ R/W	R/W	R/W	R/W	R/W	R/W	R/W	R/W		
Initial value	⇒ 0	0	0	0	0	0	0	0		

Serial Interrupt Control Register (Upper)

Address : 000033 _H	15	14	13	12	11	10	9	8	↔	Bit number SICRH
	IRQEN	RSEN	BUSY	OBE3	OBE2	OBE1	OBE0B	OBE0A		
Read/write	⇒ R/W	R/W	R	R/W	R/W	R/W	R/W	R/W		
Initial value	⇒ 0	0	0	0	0	0	0	0		

Serial Interrupt Frame Number Register 1

Address : 000034 _H	7	6	5	4	3	2	1	0	↔	Bit number SIFR1
	—	—	LV1	FR14	FR13	FR12	FR11	FR10		
Read/write	⇒ —	—	R/W	R/W	R/W	R/W	R/W	R/W		
Initial value	⇒ —	—	0	0	0	0	0	0		

Serial Interrupt Frame Number Register 2

Address : 000035 _H	15	14	13	12	11	10	9	8	↔	Bit number SIFR2
	—	—	LV2	FR24	FR23	FR22	FR21	FR20		
Read/write	⇒ —	—	R/W	R/W	R/W	R/W	R/W	R/W		
Initial value	⇒ —	—	0	0	0	0	0	0		

Serial Interrupt Frame Number Register 3

Address : 000036 _H	7	6	5	4	3	2	1	0	↔	Bit number SIFR3
	—	—	LV3	FR34	FR33	FR32	FR31	FR30		
Read/write	⇒ —	—	R/W	R/W	R/W	R/W	R/W	R/W		
Initial value	⇒ —	—	0	0	0	0	0	0		

Serial Interrupt Frame Number Register 4

Address : 000037 _H	15	14	13	12	11	10	9	8	↔	Bit number SIFR4
	—	—	LV4	FR44	FR43	FR42	FR41	FR40		
Read/write	⇒ —	—	R/W	R/W	R/W	R/W	R/W	R/W		
Initial value	⇒ —	—	0	0	0	0	0	0		

MB90370/375 Series

(2) Block diagram of the serial IRQ controller

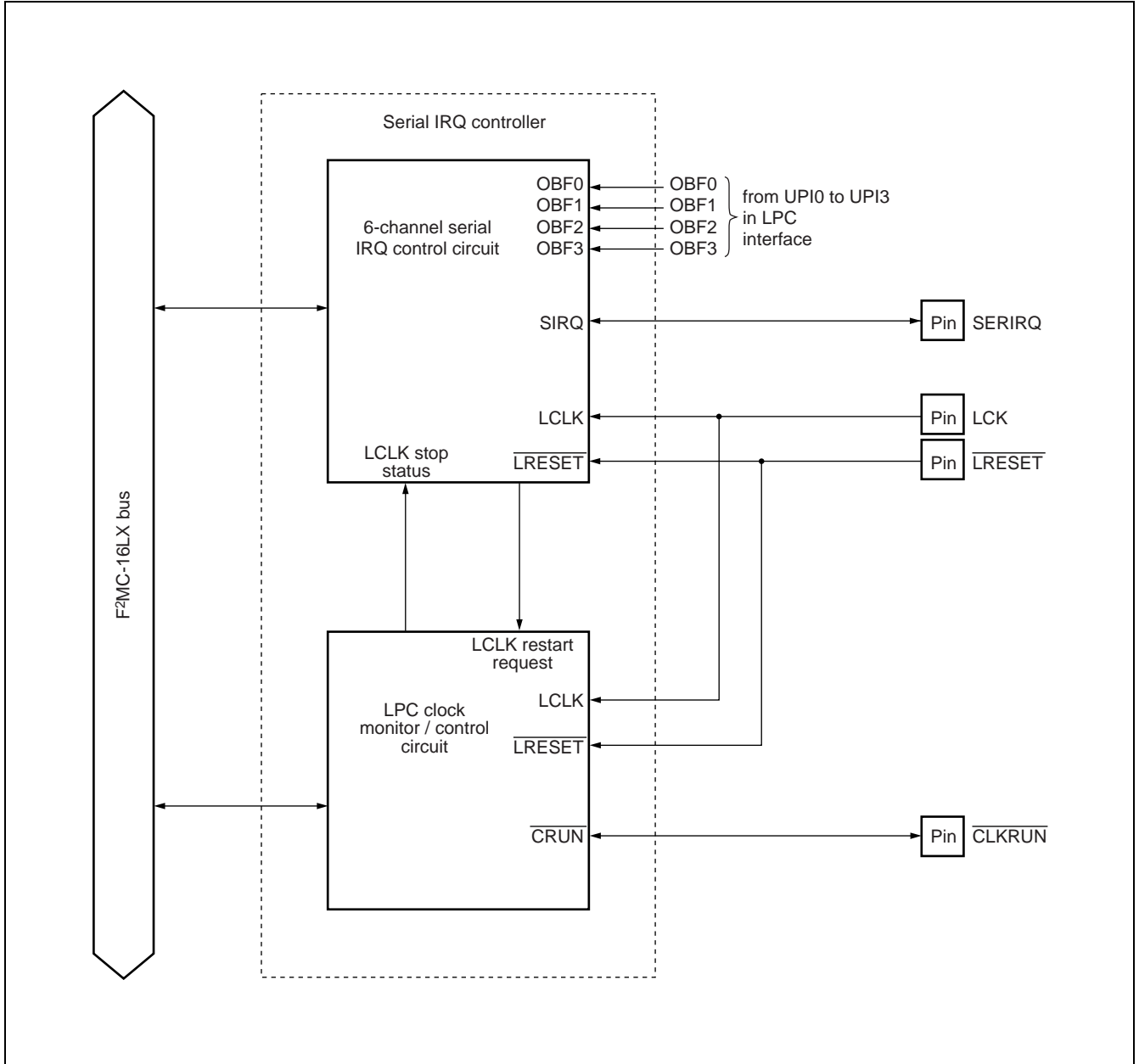

(3) Block diagram of the 6-channel serial IRQ control circuit

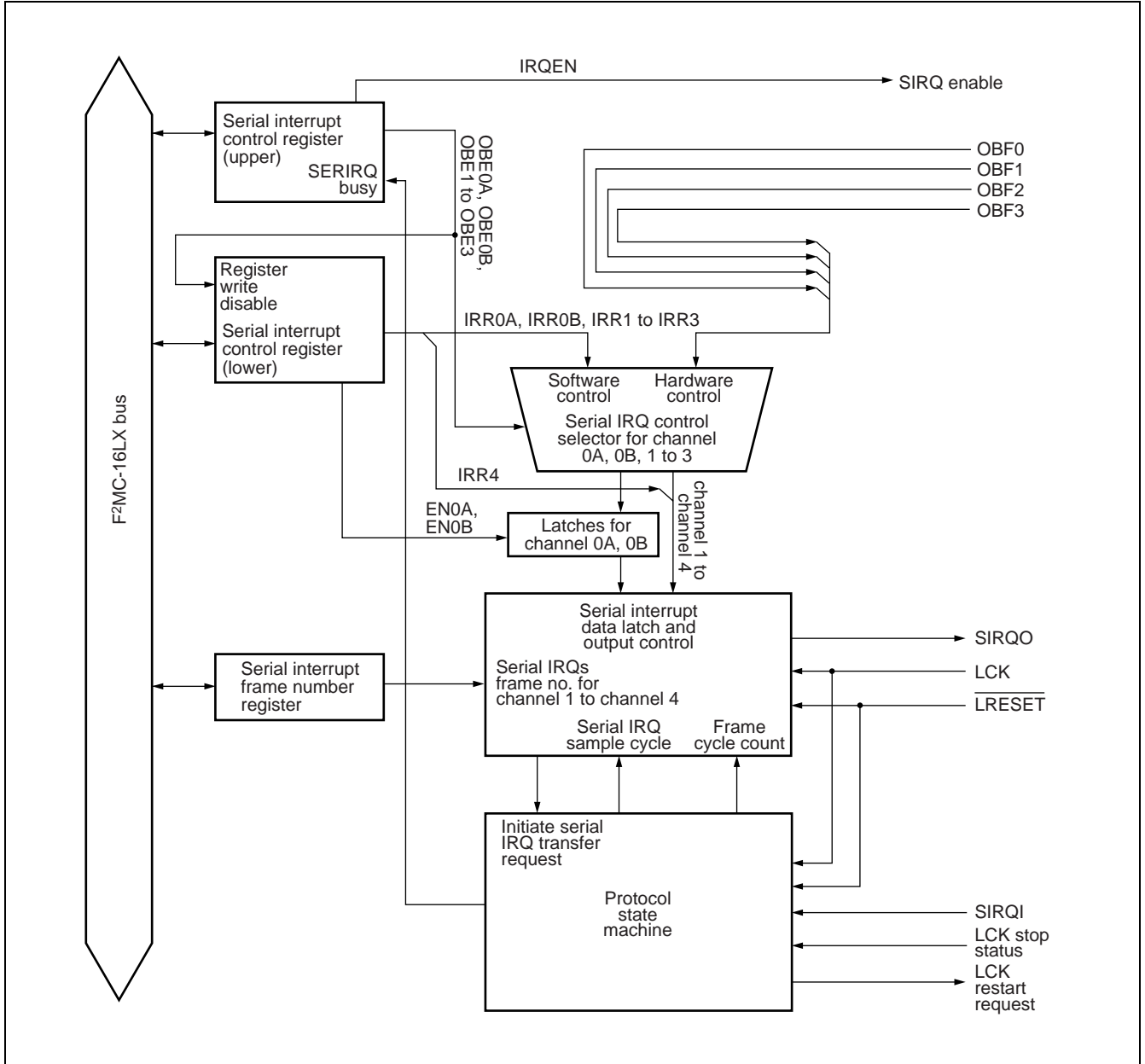

MB90370/375 Series

(4) Block diagram of the LPC clock monitor / control circuit

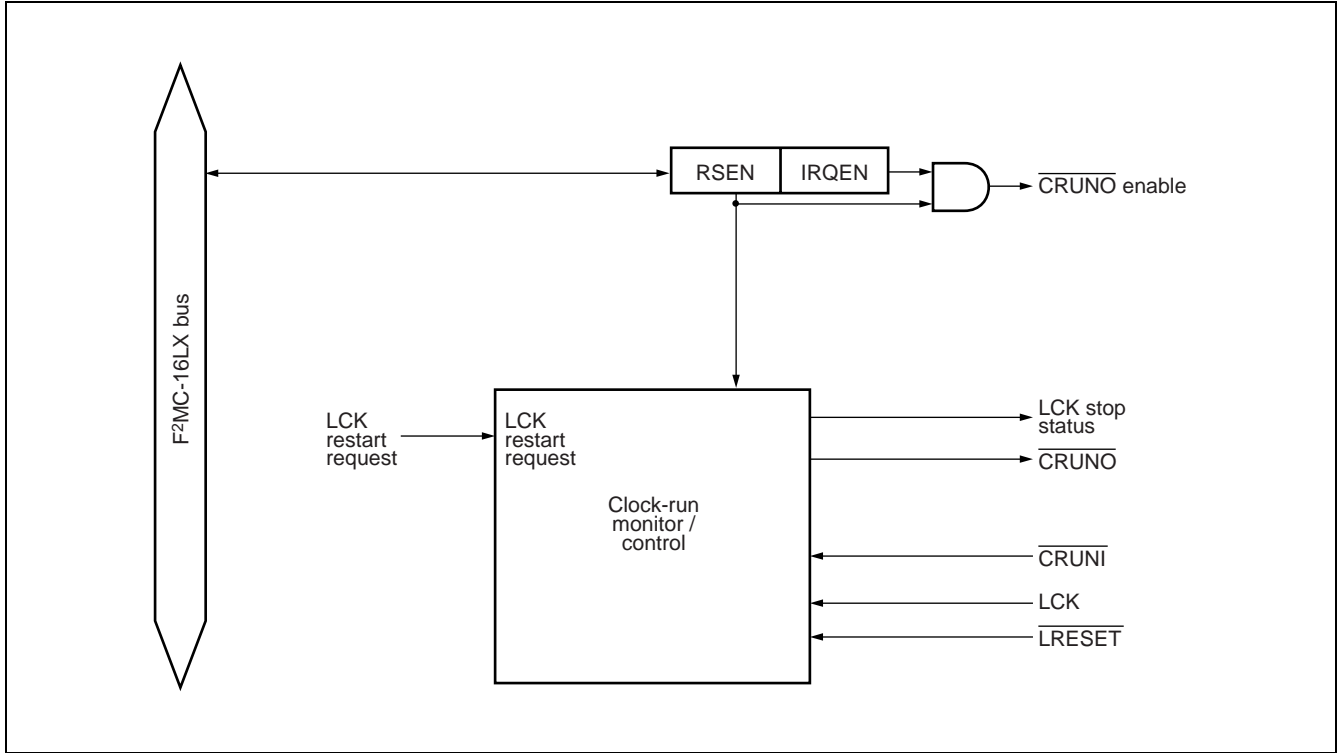

18. 3-channel PS/2 interface

The 3-channel PS/2 interface consists of 3 individual channels of PS/2 interface that can be operated concurrently. PS/2 interface is a two wires, bidirectional serial bus providing economical way for data exchange between host (keyboard controller) and device (keyboard / mouse, etc) .

(1) Register configuration of 3-channel PS/2 interface

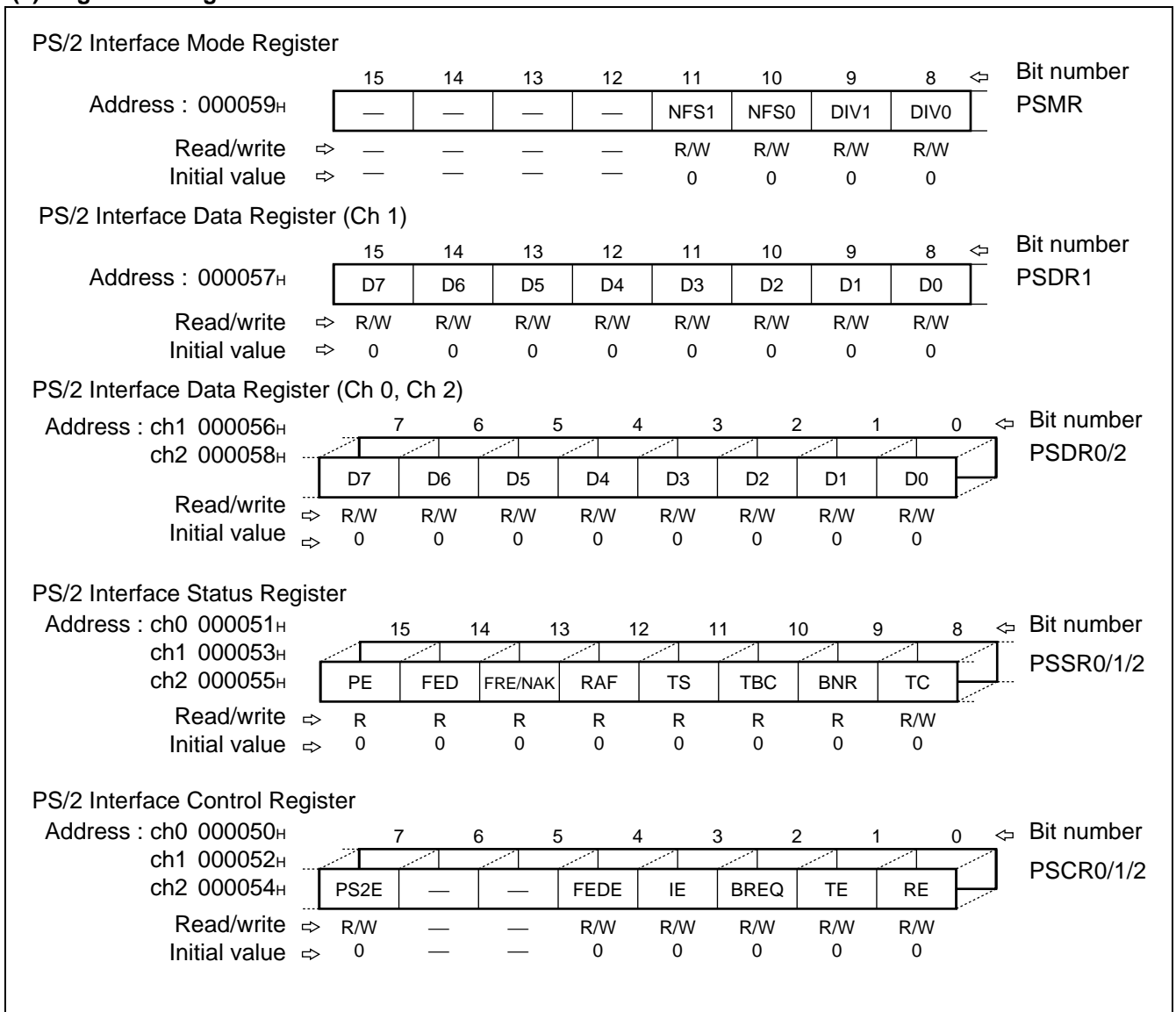

MB90370/375 Series

(2) Block diagram of 3-channel PS/2 interface

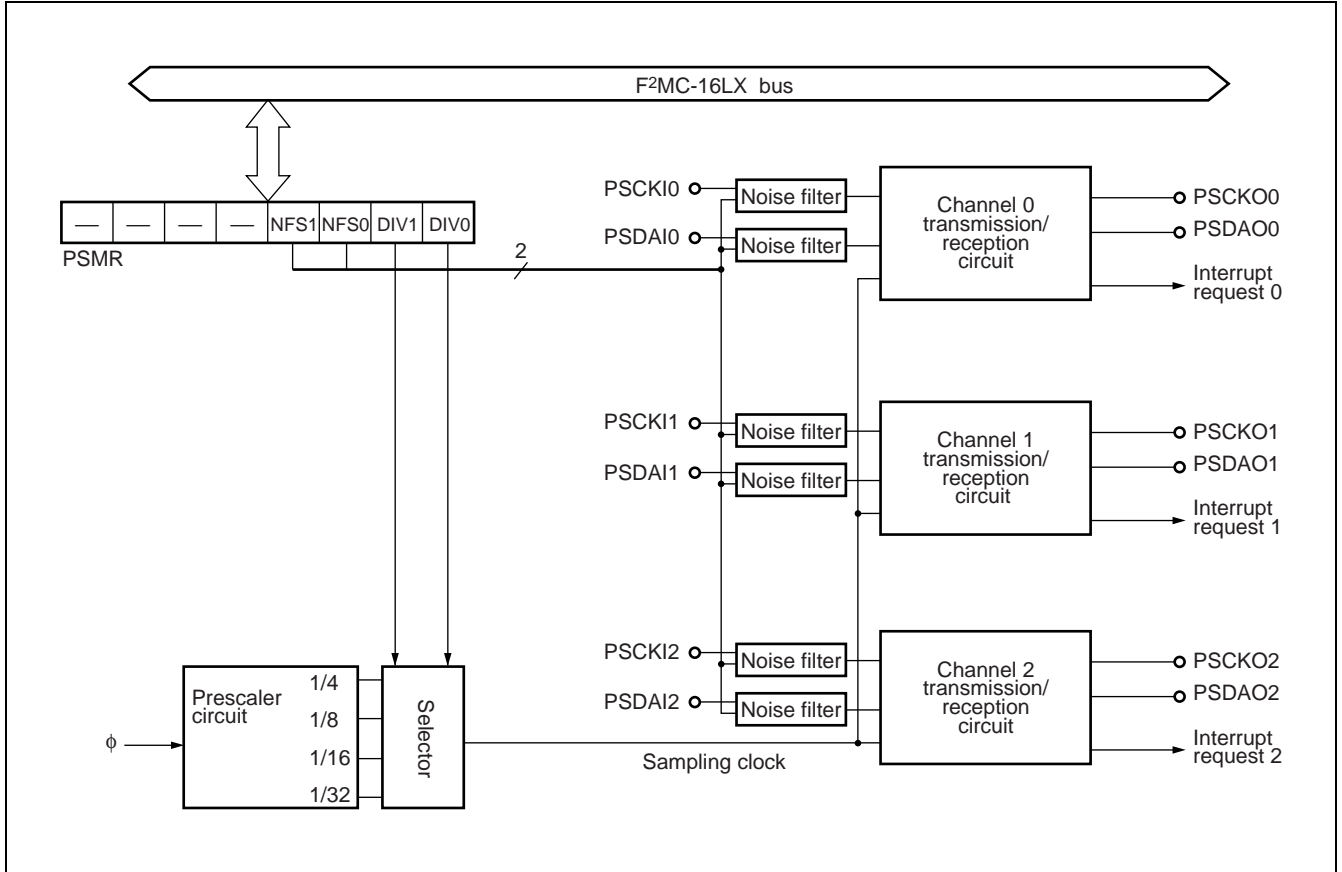

(3) Block diagram of PS/2 interface transmission/reception circuit (1 channel)

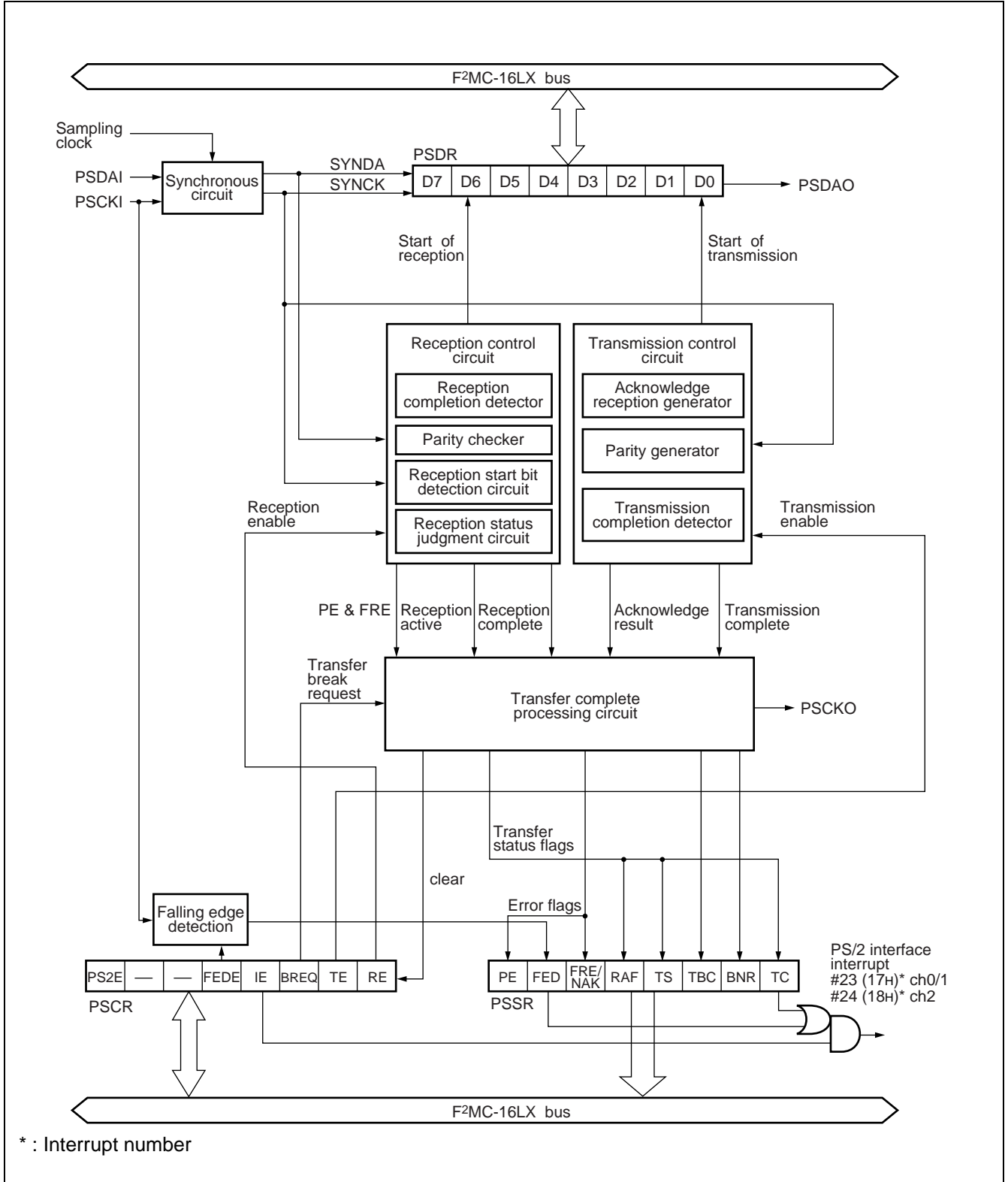

MB90370/375 Series

19. Parity generator

The parity generator is a simple circuit that generates odd / even parity based on the input data. It consists of a parity generator data register (PGDR) , an odd / even parity generation logic and a parity generator control status register (PGCSR) .

An 8-bit data can be loaded into PGDR, then the parity generator will generate odd / even parity based on the input data. Either odd or even parity can be generated by setting the PGCSR.

For odd parity generation, if the number of "1"s in the PGDR is even number, then the parity bit in PGCSR will be set to "1", otherwise the parity bit will be set to "0".

For even parity generation, if the number of "1"s in the PGDR is even number, then the parity bit in PGCSR will be set to "0", otherwise the parity bit will be set to "1".

Table shows some examples of odd / even parity generation.

Input data	Parity bit (odd parity)	Parity bit (even parity)
0000 0000 _B	1	0
0101 0101 _B	1	0
1000 0000 _B	0	1
1010 1011 _B	0	1

(1) Register configuration of parity generator

Parity Generator Data Register									
Address : 000018 _H	7	6	5	4	3	2	1	0	↔ Bit number PGDR
	D7	D6	D5	D4	D3	D2	D1	D0	
Read/write	⇒ R/W	R/W	R/W	R/W	R/W	R/W	R/W	R/W	
Initial value	⇒ X	X	X	X	X	X	X	X	
Parity Generator Control Status Register									
Address : 000019 _H	15	14	13	12	11	10	9	8	↔ Bit number PGCSR
	PRTY	—	—	—	—	—	—	PSEL	
Read/write	⇒ R	—	—	—	—	—	—	R/W	
Initial value	⇒ X	—	—	—	—	—	—	0	

(2) Block diagram of parity generator

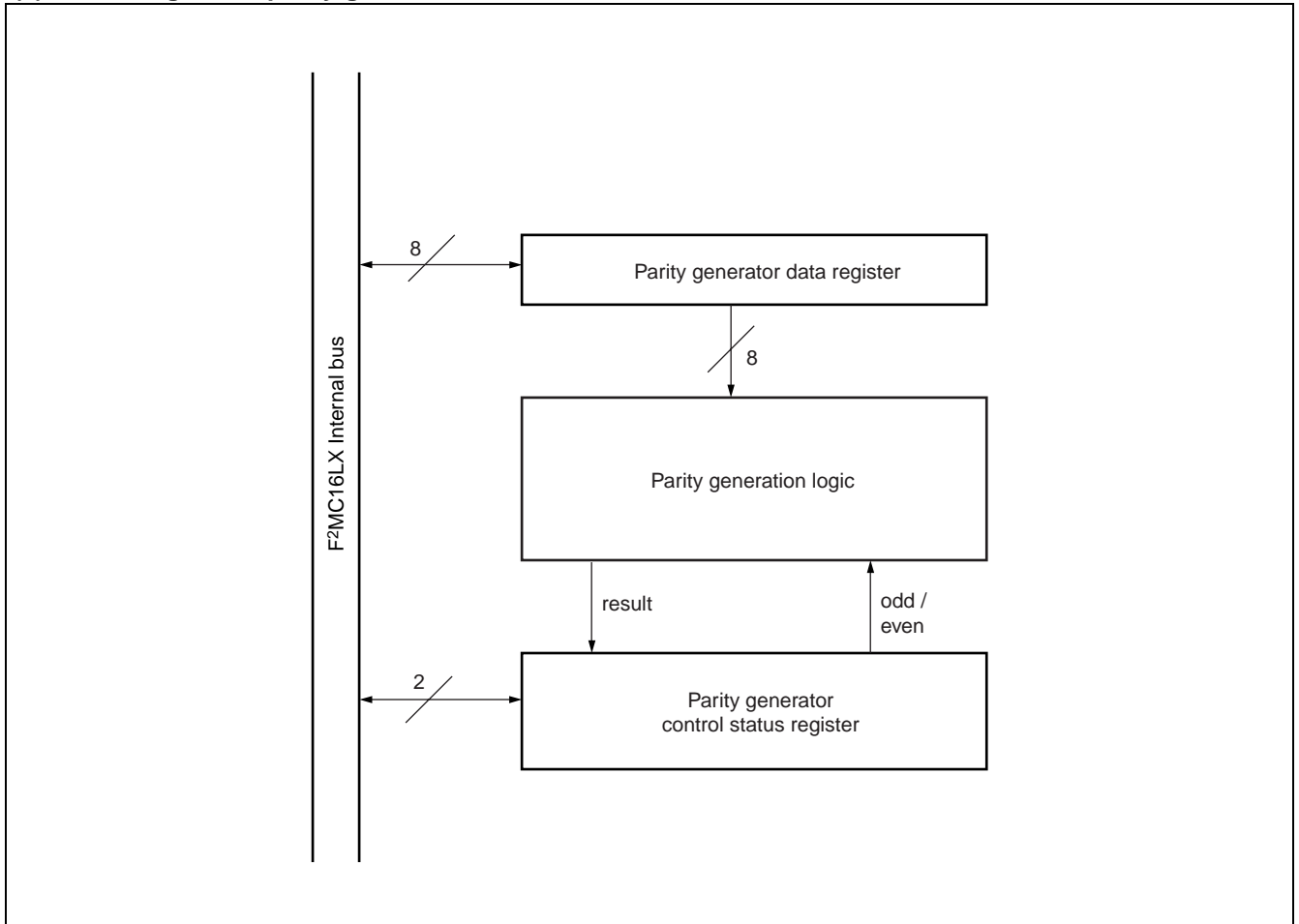

MB90370/375 Series

20. Bit decoder

The bit decoder is a simple one-hot decoder that can be used together with the keyscan inputs. It consists of a bit data register (BDR), a decoder logic and a bit result register (BRR). A 4-bit encoded data can be loaded into BDR, then the decoder logic will decode the data and store the 16-bit resulted data into BRR. A table below shows the decoder's logic.

4-bit encoded data	16-bit resulted data
0 _H	0000 0000 0000 0001 _B
1 _H	0000 0000 0000 0010 _B
2 _H	0000 0000 0000 0100 _B
3 _H	0000 0000 0000 1000 _B
4 _H	0000 0000 0001 0000 _B
5 _H	0000 0000 0010 0000 _B
6 _H	0000 0000 0100 0000 _B
7 _H	0000 0000 1000 0000 _B
8 _H	0000 0001 0000 0000 _B
9 _H	0000 0010 0000 0000 _B
A _H	0000 0100 0000 0000 _B
B _H	0000 1000 0000 0000 _B
C _H	0001 0000 0000 0000 _B
D _H	0010 0000 0000 0000 _B
E _H	0100 0000 0000 0000 _B
F _H	1000 0000 0000 0000 _B

(1) Register configuration of bit decoder

Bit Data Register									
Address : 0000E1 _H	15	14	13	12	11	10	9	8	⇐ Bit number
	—	—	—	—	D3	D2	D1	D0	BDR
Read/write ⇐	—	—	—	—	R/W	R/W	R/W	R/W	
Initial value ⇐	—	—	—	—	X	X	X	X	
Bit Result Register (Upper)									
Address : 0000E3 _H	15	14	13	12	11	10	9	8	⇐ Bit number
	R15	R14	R13	R12	R11	R10	R9	R8	BRRH
Read/write ⇐	R	R	R	R	R	R	R	R	
Initial value ⇐	X	X	X	X	X	X	X	X	
Bit Result Register (Lower)									
Address : 0000E2 _H	7	6	5	4	3	2	1	0	⇐ Bit number
	R7	R6	R5	R4	R3	R2	R1	R0	BRRL
Read/write ⇐	R	R	R	R	R	R	R	R	
Initial value ⇐	X	X	X	X	X	X	X	X	

(2) Block diagram of bit decoder

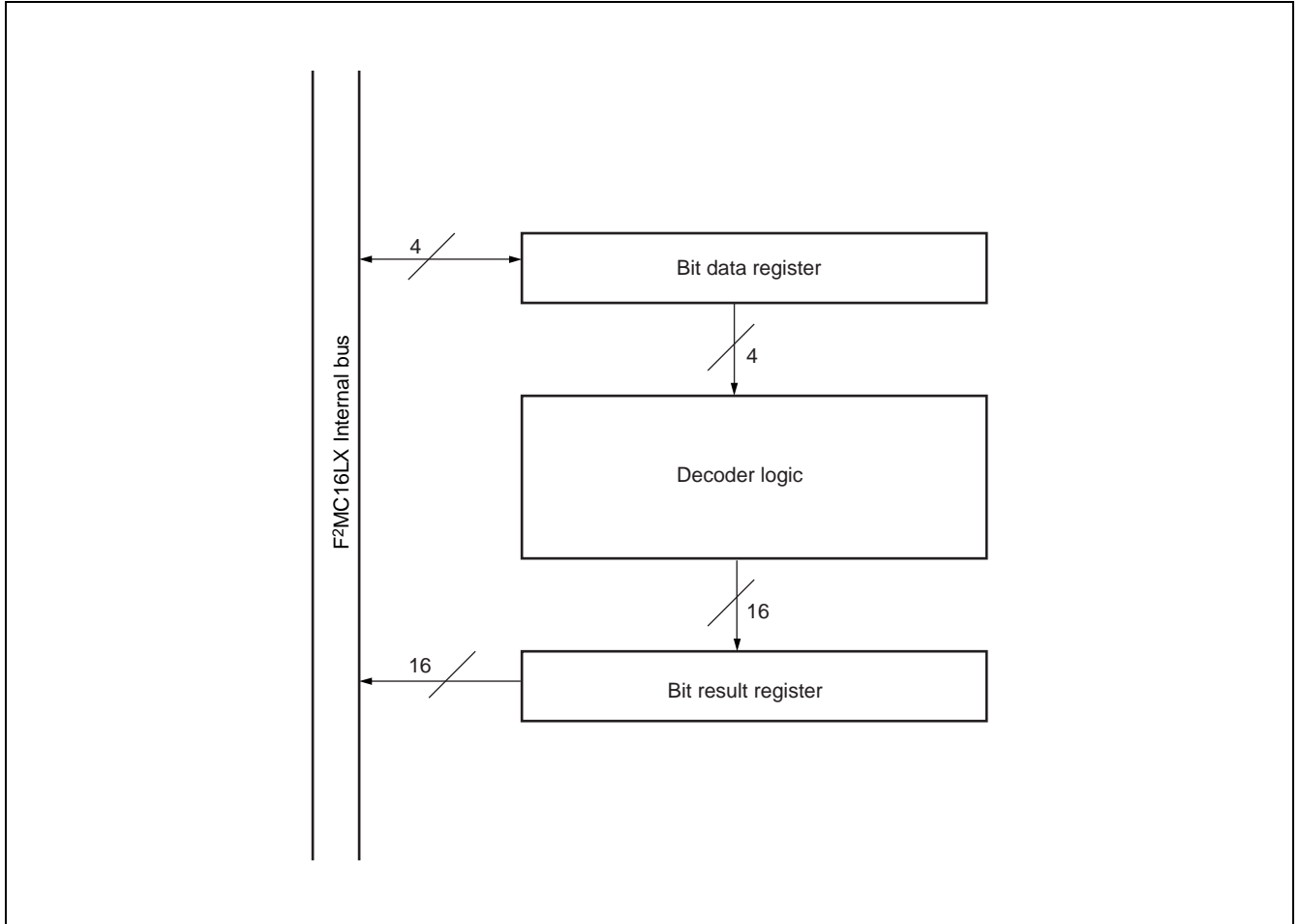

MB90370/375 Series

21. Wake-up interrupt

The wake-up interrupt circuit detects the signals of the “L” levels input to the external interrupt pins and to generate interrupt request to the CPU. These interrupts can wake up the CPU from standby mode.

Wake-up interrupt pins : 8 pins (P00/KSI0 to P07/KSI7) .

Wake-up interrupt sources : “L” level signal input to a wake-up interrupt pin.

Interrupt control : Enables or disables to input wake-up interrupt controlled by wake-up interrupt control register (EICR) .

Interrupt flag : IRQ flag bit of wake-up interrupt flag register (EIFR) . Flag set when there is an IRQ.

Interrupt request : Interrupt request #20 is generated if any enabled external interrupt pin goes LOW.

(1) Register configuration of wake-up interrupt

Wake-up Interrupt Flag Register										
Address : 0000AD _H	15	14	13	12	11	10	9	8	↔	Bit number EIFR
	—	—	—	—	—	—	—	WIF		
Read/write	⇒	—	—	—	—	—	—	R/W		
Initial value	⇒	—	—	—	—	—	—	0		
Wake-up Interrupt Control Register										
Address : 0000AC _H	7	6	5	4	3	2	1	0	↔	Bit number EICR
	EN7	EN6	EN5	EN4	EN3	EN2	EN1	EN0		
Read/write	⇒	R/W	R/W	R/W	R/W	R/W	R/W	R/W	R/W	
Initial value	⇒	0	0	0	0	0	0	0	0	

(2) Block diagram of wake-up interrupt

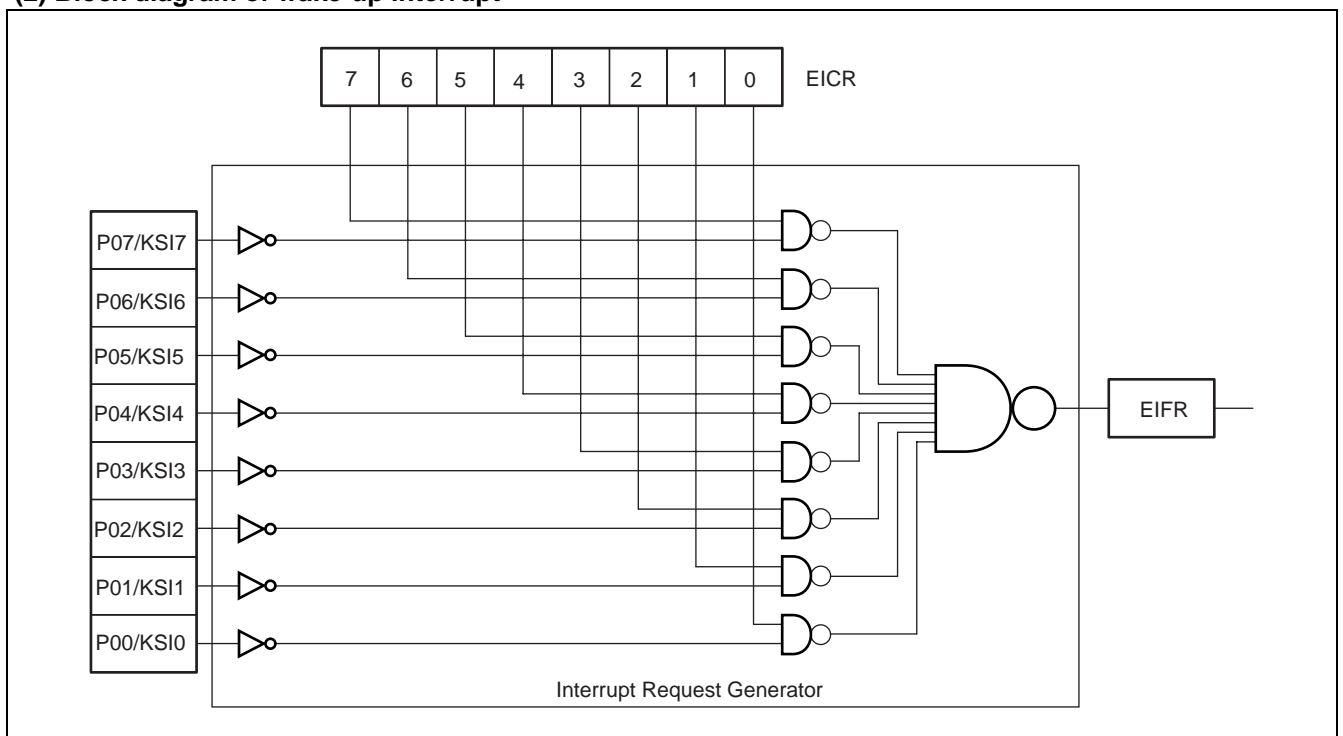

22. DTP/External interrupts

The DTP (Data Transfer Peripheral) /external interrupt circuit is activated by the signal supplied to a DTP/external interrupt pin. The CPU accepts the signal using the same as procedure used for normal hardware interrupts and generates external interrupts or activates the extended intelligent I/O service (EI²OS) .

Features of DTP/External interrupt :

- Total 6 external interrupt channels
- Two request levels (“H” and “L”) are provided for the intelligent I/O service.
- Four request levels (rise/fall edge, fall edge, “H” level and “L” level) are provided for external interrupt requests .

(1) Register configuration

DTP/Interrupt Source Register										
Address : 000027H	15	14	13	12	11	10	9	8	↔	Bit number EIRR
	—	—	ER5	ER4	ER3	ER2	ER1	ER0		
Read/write	↔	—	R/W	R/W	R/W	R/W	R/W	R/W		
Initial value	↔	—	0	0	0	0	0	0		
DTP/Interrupt Enable Register										
Address : 000026H	7	6	5	4	3	2	1	0	↔	Bit number ENIR
	—	—	EN5	EN4	EN3	EN2	EN1	EN0		
Read/write	↔	—	R/W	R/W	R/W	R/W	R/W	R/W		
Initial value	↔	—	0	0	0	0	0	0		
Request Level Setting Register (Upper)										
Address : 000029H	15	14	13	12	11	10	9	8	↔	Bit number ELVRH
	—	—	—	—	LB5	LA5	LB4	LA4		
Read/write	↔	—	—	—	R/W	R/W	R/W	R/W		
Initial value	↔	—	—	—	0	0	0	0		
Request Level Setting Register (Lower)										
Address : 000028H	7	6	5	4	3	2	1	0	↔	Bit number ELVRL
	LB3	LA3	LB2	LA2	LB1	LA1	LB0	LA0		
Read/write	↔	R/W	R/W	R/W	R/W	R/W	R/W	R/W		
Initial value	↔	0	0	0	0	0	0	0		

MB90370/375 Series

(2) Block diagram of DTP/External interrupts

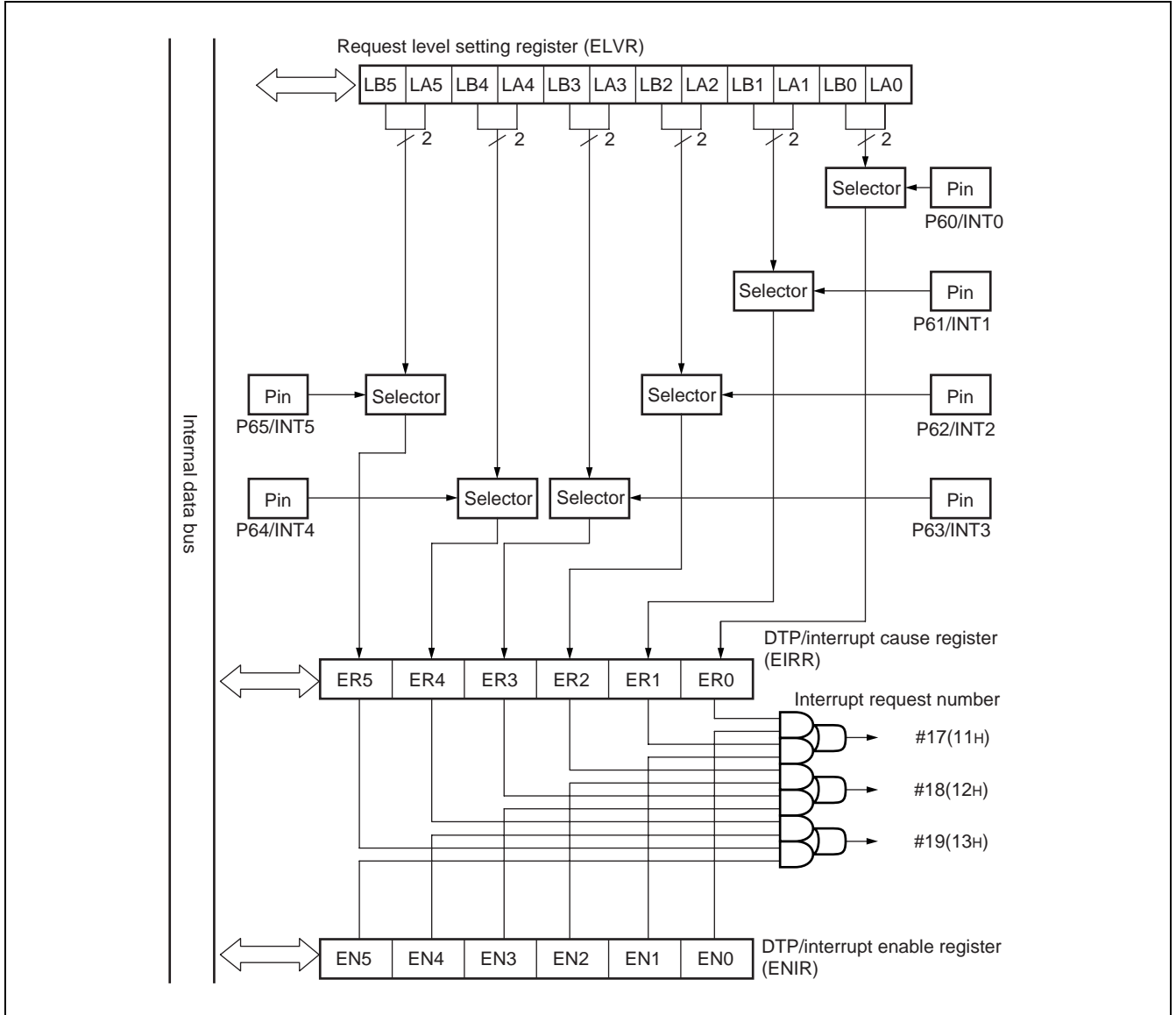

23. Delayed interrupt generation module

The delayed interrupt generation module is used to generate a task switching interrupt. Interrupt requests to the F²MC-16LX CPU can be generated and cleared by software using this module.

(1) Register configuration

Delayed Interrupt Generator Module Register								Bit number	
Address : 00009FH	15	14	13	12	11	10	9	8	DIRR
	—	—	—	—	—	—	—	R0	
Read/write	⇒	—	—	—	—	—	—	R/W	
Initial value	⇒	—	—	—	—	—	—	0	

(2) Block diagram

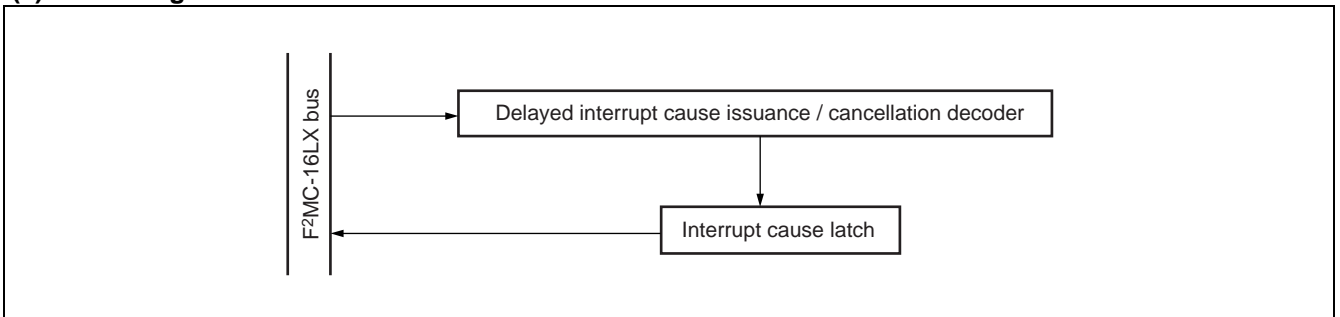

MB90370/375 Series

24. ROM correction function

When an address matches the value set in the address detection register, the instruction code to be loaded into the CPU is forced to be replaced with the INT9 instruction code (01H) . When executing a set instruction, the CPU executes the INT9 instruction. The ROM correction function is implemented by processing using the INT9 interrupt routine.

The device contains two address detection registers, each provided with a compare enable bit. When the value set in the address detection register matches an address and the interrupt enable bit is "1", the instruction code to be loaded into the CPU is forced to be replaced with the INT9 instruction code.

(1) Register configuration

Program Address Detection Control / Status Register									
Address : 00009EH	7	6	5	4	3	2	1	0	↔ Bit number PACSR
	—	—	—	—	AD1E	AD1D	AD0E	AD0D	
Read/write	⇒ —	⇒ —	⇒ —	⇒ —	⇒ R/W	⇒ R/W	⇒ R/W	⇒ R/W	
Initial value	⇒ —	⇒ —	⇒ —	⇒ —	⇒ 0	⇒ 0	⇒ 0	⇒ 0	
Program Address Detection Register 0 (Upper Byte)									
Address : 001FF2H	7	6	5	4	3	2	1	0	↔ Bit number PADRH0
Read/write	⇒ R/W	⇒ R/W	⇒ R/W	⇒ R/W	⇒ R/W	⇒ R/W	⇒ R/W	⇒ R/W	
Initial value	⇒ X	⇒ X	⇒ X	⇒ X	⇒ X	⇒ X	⇒ X	⇒ X	
Program Address Detection Register 0 (Middle Byte)									
Address : 001FF1H	15	14	13	12	11	10	9	8	↔ Bit number PADRM0
Read/write	⇒ R/W	⇒ R/W	⇒ R/W	⇒ R/W	⇒ R/W	⇒ R/W	⇒ R/W	⇒ R/W	
Initial value	⇒ X	⇒ X	⇒ X	⇒ X	⇒ X	⇒ X	⇒ X	⇒ X	
Program Address Detection Register 0 (Lower Byte)									
Address : 001FF0H	7	6	5	4	3	2	1	0	↔ Bit number PADRL0
Read/write	⇒ R/W	⇒ R/W	⇒ R/W	⇒ R/W	⇒ R/W	⇒ R/W	⇒ R/W	⇒ R/W	
Initial value	⇒ X	⇒ X	⇒ X	⇒ X	⇒ X	⇒ X	⇒ X	⇒ X	

(Continued)

MB90370/375 Series

(Continued)

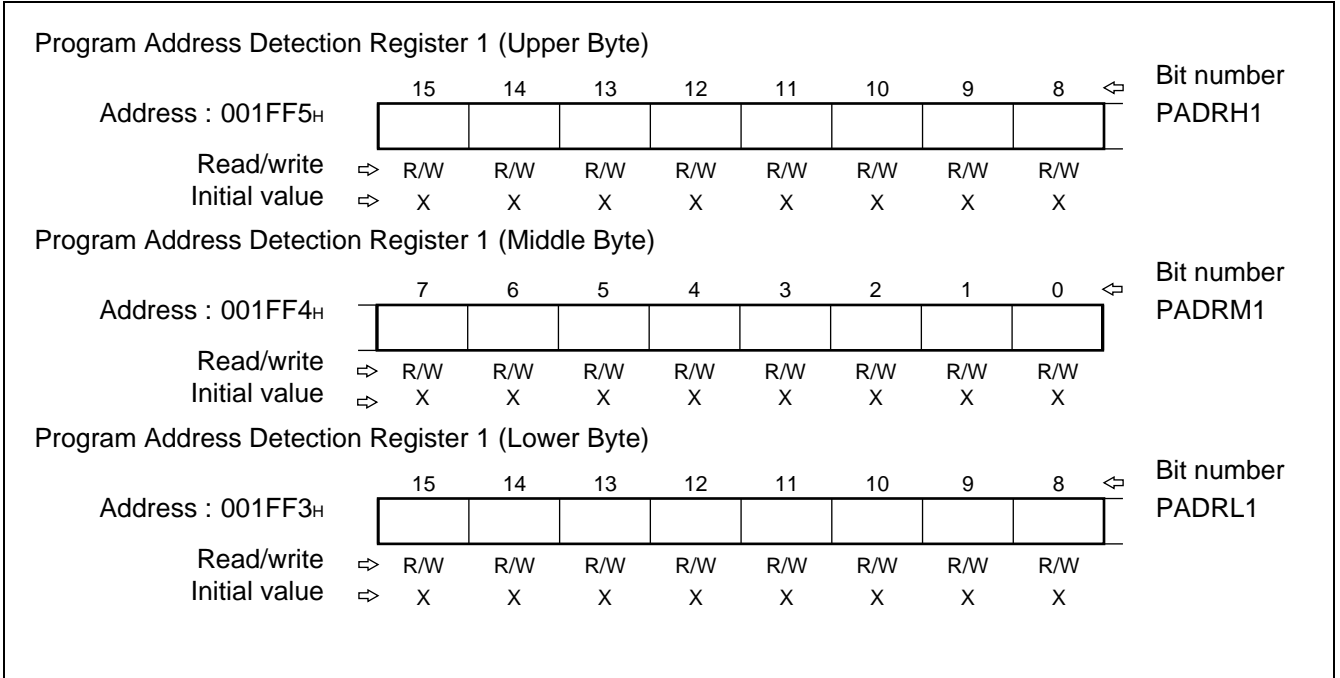

(2) Block diagram

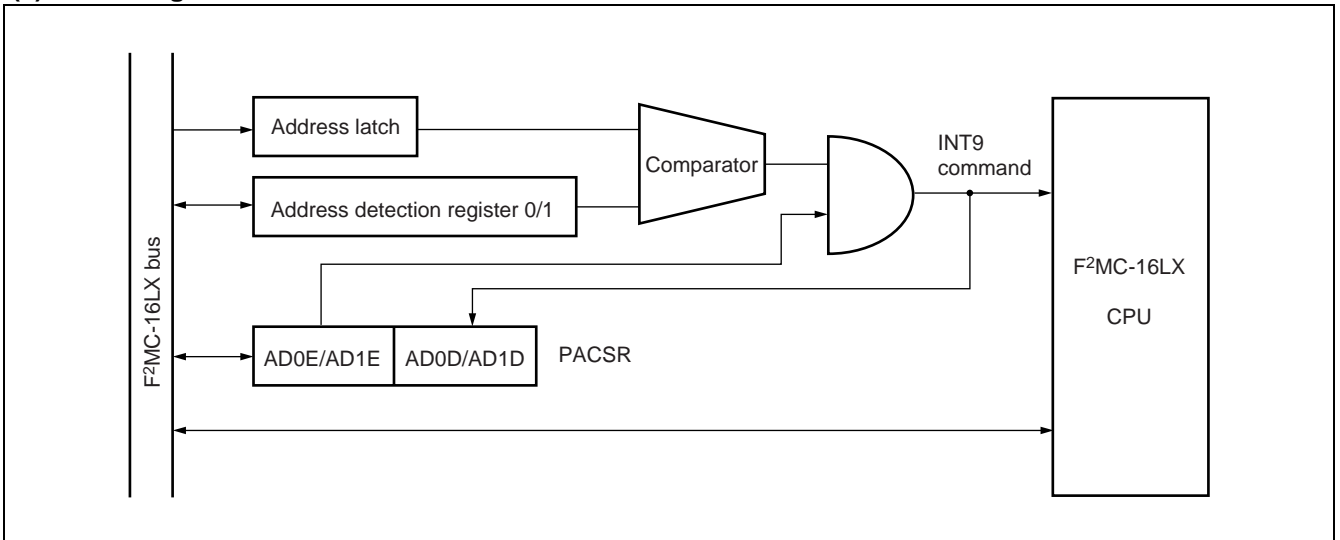

MB90370/375 Series

25. ROM mirroring function selection module

The ROM mirroring function selection module can select what the FF bank allocated the ROM sees through the 00 bank according to register settings.

(1) Register configuration

ROM Mirror Function Selection Register								Bit number	
Address : 0006FH	15	14	13	12	11	10	9	8	ROMM
Read/write	⇒	—	—	—	—	—	—	—	W
Initial value	⇒	—	—	—	—	—	—	—	1

(2) Block diagram

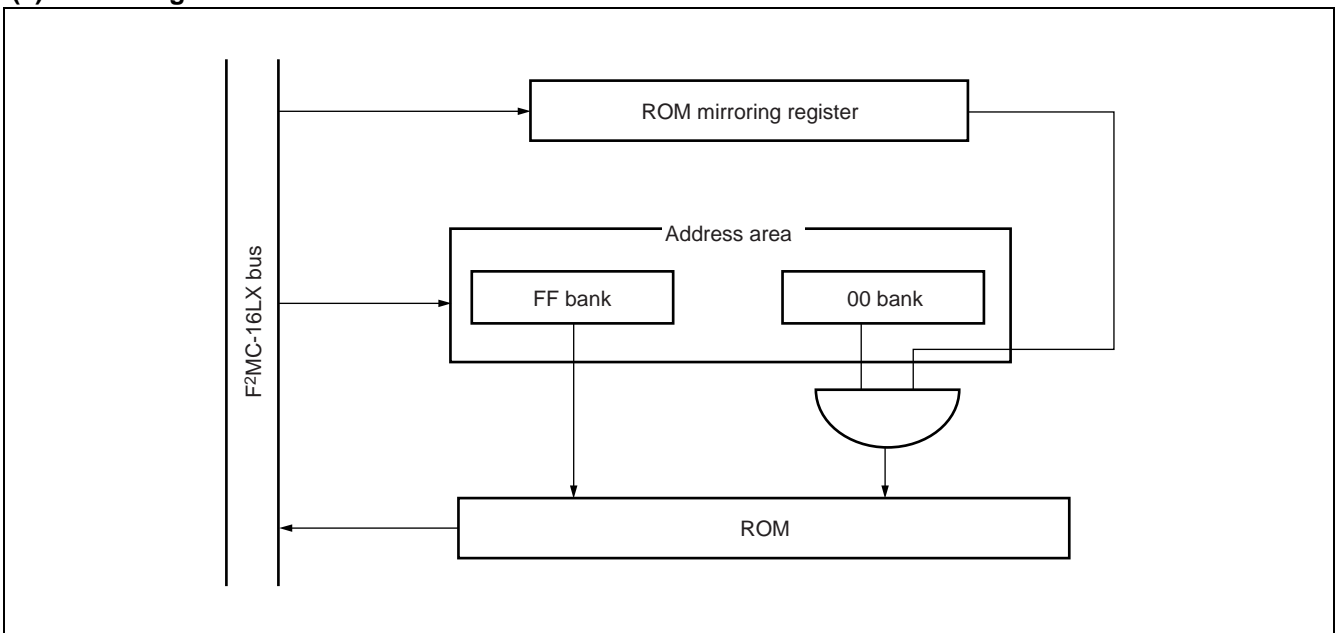

26. 512K bit flash memory

The 512K bit flash memory is allocated in the FF_H banks on the CPU memory map. Like masked ROM, flash memory is read-accessible and program-accessible to the CPU using the flash memory interface circuit. The flash memory can be programmed/erased by the instruction from the CPU via the flash memory interface circuit. The flash memory can therefore be reprogrammed (updated) while still on the circuit board under integrated CPU control, allowing program code and data to be improved efficiently. Note that sector operations such as “enable sector protect” cannot be used.

Features of 512K bit flash memory :

- 64 Kwords × 8 bits / 32 Kwords × 16 bits (16 K + 8 K + 8 K + 32 K) sector configuration
- Automatic program algorithm (same as the Embedded Algorithm* : MBM29F400TA)
- Installation of the deletion temporary stop/delete restart function
- Write/delete completion detected by the data polling or toggle bit
- Write/delete completion detected by the CPU interrupt
- Compatibility with the JEDEC standard-type command
- Each sector deletion can be executed (Sectors can be freely combined) .
- Number of write/delete operations 10,000 times guaranteed

* : Embedded Algorithm is a trademark of Advanced Micro Devices, Inc.

(1) Register configuration

Flash Memory Control Status Register									Bit number
Address : 0000AE _H	7	6	5	4	3	2	1	0	↔
	INTE	RDYINT	WE	RDY	Reserved	LPM1	Reserved	LPM0	FMCS
Read/write	⇒ R/W	R/W	R/W	R	W	R/W	W	R/W	
Initial value	⇒ 0	0	0	1	0	0	0	0	

MB90370/375 Series

(2) Sector configuration of 512K bits flash memory

The 512K bits flash memory has the sector configuration illustrated below. The addresses in the illustration are the upper and lower addresses of each sector.

When accessed from the CPU, SA0 and SA1 to SA3 are allocated in the FF bank registers, respectively.

Flash memory	CPU address	*Writer address
SA3 (16 Kbytes)	FFFFFFH	7FFFFH
	FFC000H	7C000H
SA2 (8 Kbytes)	FFBFFFH	7BFFFH
	FFA000H	7A000H
SA1 (8 Kbytes)	FF9FFFH	79FFFH
	FF8000H	78000H
SA0 (32 Kbytes)	FF7FFFH	77FFFH
	FF0000H	70000H

* : Writer addresses correspond to CPU addresses when data is programmed in flash memory by a parallel writer. Writer addresses are used to program/erase data using a general-purpose writer.

MB90370/375 Series

■ ELECTRICAL CHARACTERISTICS

1. Absolute Maximum Ratings

($V_{SS} = AV_{SS} = CV_{SS} = 0.0\text{ V}$)

Parameter	Symbol	Rating		Unit	Remarks
		Min	Max		
Power supply voltage	V_{CC}	$V_{SS} - 0.3$	$V_{SS} + 4.0$	V	
	CV_{CC}	$V_{SS} - 0.3$	$V_{SS} + 4.0$	V	$V_{CC} \geq CV_{CC}$ *1
	AV_{CC}	$V_{SS} - 0.3$	$V_{SS} + 4.0$	V	$V_{CC} \geq AV_{CC}$ *1
A/D converter reference input voltage	AVR	$V_{SS} - 0.3$	$V_{SS} + 4.0$	V	$AV_{CC} \geq AVR$, $AVR \geq AV_{SS}$
Comparator reference input voltage	CVRH1 CVRH2 CVRL	$V_{SS} - 0.3$	$V_{SS} + 4.0$	V	$CV_{CC} \geq CVRH1$, $CVRH1 \geq CV_{SS}$ $CV_{CC} \geq CVRH2$, $CVRH2 \geq CV_{SS}$ $CV_{CC} \geq CVRL$, $CVRL \geq CV_{SS}$
LCD power supply voltage	V1 to V3	$V_{SS} - 0.3$	$V_{SS} + 4.0$	V	V1 to V3 must not exceed V_{CC} Not for MB90F377
Input voltage	V_{I1}	$V_{SS} - 0.3$	$V_{SS} + 4.0$	V	All pins except P40 to P45, P80 to P82, P90 to P95 *2
	V_{I2}	$V_{SS} - 0.3$	$V_{SS} + 6.0$	V	P40 to P45, P80 to P82, P90 to P95
Output voltage	V_O	$V_{SS} - 0.3$	$V_{SS} + 4.0$	V	*2
Maximum clamp current	I_{CLAMP}	-2.0	+2.0	mA	*4
Total maximum clamp current	$\Sigma I_{CLAMP} $	—	20	mA	*4
“L” level maximum output current	I_{OL1}	—	10	mA	All pins except PF0 to PF7*3
	I_{OL2}	—	20	mA	PF0 to PF7*3
“L” level average output current	I_{OLAV1}	—	4	mA	All pins except PF0 to PF7 Average output current = operating current \times operating efficiency
	I_{OLAV2}	—	12	mA	PF0 to PF7 Average output current = operating current \times operating efficiency
“L” level total maximum output current	ΣI_{OL}	—	100	mA	
“L” level total average output current	ΣI_{OLAV}	—	50	mA	Average output current = operating current \times operating efficiency
“H” level maximum output current	I_{OH}	—	-10	mA	*3
“H” level average output current	I_{OHAV}	—	-3	mA	Average output current = operating current \times operating efficiency
“H” level total maximum output current	ΣI_{OH}	—	-100	mA	
“H” level total average output current	ΣI_{OHAV}	—	-50	mA	Average output current = operating current \times operating efficiency

(Continued)

MB90370/375 Series

(Continued)

($V_{SS} = AV_{SS} = CV_{SS} = 0.0\text{ V}$)

Parameter	Symbol	Rting		Unit	Remarks
		Min	Max		
Power consumption	P_D	—	200	mW	
Operating temperature	T_A	-40	+85	°C	
Storage temperature	T_{stg}	-55	+150	°C	

*1 : Set AV_{CC} , CV_{CC} and V_{CC} at the same voltage. Take care so that AVR, CVRH1, CVRH2 and CVRL do not exceed $V_{CC} + 0.3\text{ V}$ when the power is turned on.

*2 : V_I and V_O shall never exceed $V_{CC} + 0.3\text{ V}$. V_I should not exceed the specified ratings. However if the maximum current to/from an input is limited by some means with external components, the I_{CLAMP} rating supersedes the V_I rating.

*3 : The maximum output current is a peak value for a corresponding pin.

*4 : Applicable to pins : P00 to P07, P10 to P17, P20 to P27, P30 to P37, P47, P50 to P57, P60 to P67, P70 to P77, PA0 to PA6, PC3 to PC7, PD0 to PD3, PD6, PD7

Use within recommended operating conditions.

Use at DC voltage (current) .

The +B signal should always be applied a limiting resistance placed between the +B signal and the microcontroller.

The value of the limiting resistance should be set so that when the +B signal is applied the input current to the microcontroller pin does not exceed rated values, either instantaneously or for prolonged periods.

Note that when the microcontroller drive current is low, such as in the power saving modes, the +B input potential may pass through the protective diode and increase the potential at the V_{CC} pin, and this may affect other devices.

Note that if a +B signal is input when the microcontroller power supply is off (not fixed at 0V) , the power supply is provided from the pins, so that incomplete operation may result.

Note that if the +B input is applied during power-on, the power supply is provided from the pins and the resulting supply voltage may not be sufficient to operate the power-on reset.

Care must be taken not to leave the +B input pin open.

Note that analog system input/output pins other than the A/D input pins (LCD drive pins, comparator input pins, etc.) cannot accept +B signal input.

Sample recommended circuits :

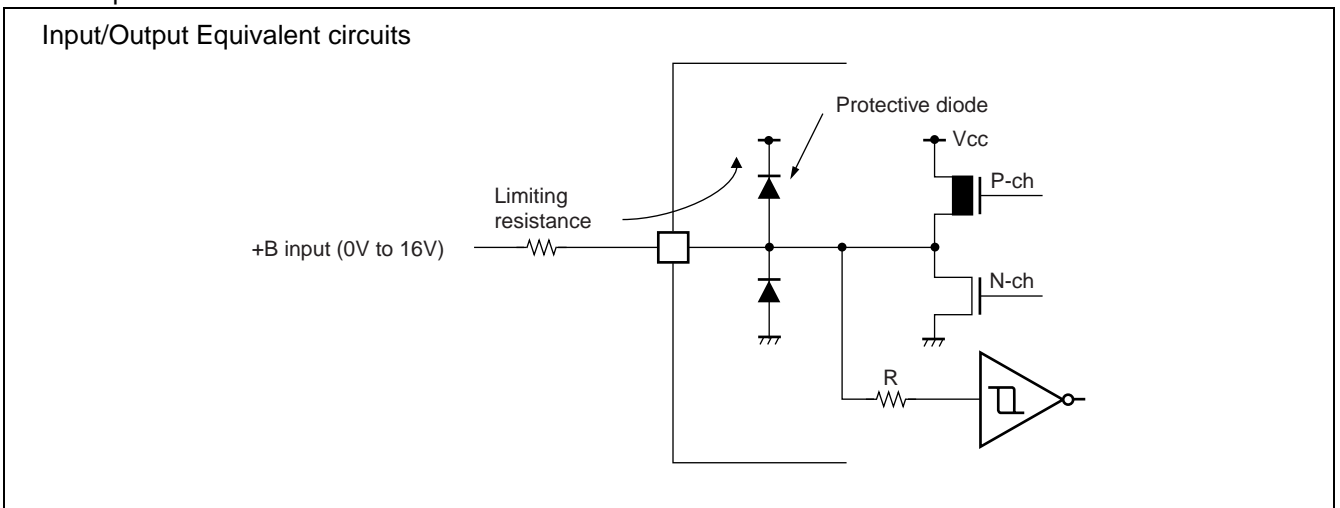

WARNING: Semiconductor devices can be permanently damaged by application of stress (voltage, current, temperature, etc.) in excess of absolute maximum ratings. Do not exceed these ratings.

MB90370/375 Series

2. Recommended Operating Conditions

($V_{SS} = AV_{SS} = CV_{SS} = 0.0\text{ V}$)

Parameter	Symbol	Value		Unit	Remarks
		Min	Max		
Power supply voltage *1	V_{CC}	3.0	3.6	V	Normal operation assurance range
	CV_{CC}	3.3	3.6	V	
	V_{CC}	1.8	3.6	V	Retains the RAM state in stop mode
A/D converter reference input voltage *2	AVR	0	AV_{CC}	V	Normal operation assurance range
LCD power supply voltage	V1 to V3	V_{SS}	V_{CC}	V	V1 to V3 pins (The optimum value is dependent on the LCD element in use.) Not for MB90F377
Operating temperature	T_A	-40	+85	°C	

*1 : Set AV_{CC} , CV_{CC} and V_{CC} at the same voltage.

*2 : Take care so that AVR, CVRH1, CVRH2 and CVRL do not exceed $V_{CC} + 0.3\text{ V}$ when power is turned on.

WARNING: The recommended operating conditions are required in order to ensure the normal operation of the semiconductor device. All of the device's electrical characteristics are warranted when the device is operated within these ranges.

Always use semiconductor devices within their recommended operating condition ranges. Operation outside these ranges may adversely affect reliability and could result in device failure.

No warranty is made with respect to uses, operating conditions, or combinations not represented on the data sheet. Users considering application outside the listed conditions are advised to contact their FUJITSU representatives beforehand.

MB90370/375 Series

3. DC Characteristics

($V_{CC} = AV_{CC} = CV_{CC} = 3.0\text{ V to }3.6\text{ V}$, $V_{SS} = AV_{SS} = CV_{SS} = 0.0\text{ V}$, $T_A = -40\text{ }^\circ\text{C to }+85\text{ }^\circ\text{C}$)

Parameter	Symbol	Pin name	Condition	Value			Unit	Remarks
				Min	Typ	Max		
"H" level input voltage	V_{IH}	P10 to P17 P20 to P27 P30 to P37 P46, P47 P50 to P57 PA0 to PA6 PB0 to PB7 PC0 to PC7 PD0 to PD7 PF0 to PF7	—	$0.7 V_{CC}$	—	$V_{CC} + 0.3$	V	CMOS input pins
	V_{IHS}	P00 to P07 P60 to P67 P70 to P77 PE0 to PE7 \overline{RST}		$0.8 V_{CC}$	—	$V_{CC} + 0.3$	V	CMOS hysteresis input pins
	V_{IHS5}	P40 to P45		$0.8 V_{CC}$	—	$V_{SS} + 5.5$	V	5 V tolerant CMOS hysteresis input pins
	V_{IH5}	P82		$0.7 V_{CC}$	—	$V_{SS} + 5.5$	V	5 V tolerant CMOS input pin
	V_{IHSM}	P80, P81 P90 to P95		2.1	—	$V_{SS} + 5.5$	V	SMbus input pins
	V_{IHM}	MD0 to MD2		$V_{CC} - 0.3$	—	$V_{CC} + 0.3$	V	Mode pins
"L" level input voltage	V_{IL}	P10 to P17 P20 to P27 P30 to P37 P46, P47 P50 to P57 P82 PA0 to PA6 PB0 to PB7 PC0 to PC7 PD0 to PD7 PF0 to PF7	—	$V_{SS} - 0.3$	—	$0.3 V_{CC}$	V	CMOS input pins
	V_{ILS}	P00 to P07 P40 to P45 P60 to P67 P70 to P77 PE0 to PE7 \overline{RST}		$V_{SS} - 0.3$	—	$0.2 V_{CC}$	V	CMOS hysteresis input pins

(Continued)

MB90370/375 Series

($V_{CC} = AV_{CC} = CV_{CC} = 3.0\text{ V to }3.6\text{ V}$, $V_{SS} = AV_{SS} = CV_{SS} = 0.0\text{ V}$, $T_A = -40\text{ }^\circ\text{C to }+85\text{ }^\circ\text{C}$)

Parameter	Symbol	Pin name	Condition	Value			Unit	Remarks
				Min	Typ	Max		
“L” level input voltage	V_{ILSM}	P80, P81 P90 to P95	—	$V_{SS} - 0.3$	—	0.8	V	SMbus input pins
	V_{ILM}	MD0 to MD2		$V_{SS} - 0.3$	—	$V_{SS} + 0.3$	V	Mode pins
Open-drain output pin application voltage	V_{D5}	P40 to P45 P80 to P82 P90 to P95		$V_{SS} - 0.3$	—	$V_{SS} + 5.5$	V	
	V_D	P46	$V_{SS} - 0.3$	—	$V_{CC} + 0.3$	V		
“H” level output voltage	V_{OH1}	All port pins except P40 to P46 P80 to P82 P90 to P95 PF0 to PF7	$V_{CC} = 3.0\text{ V}$ $I_{OH1} = -4.0\text{ mA}$	$V_{CC} - 0.5$	—	—	V	
	V_{OH2}	PF0 to PF7	$V_{CC} = 3.0\text{ V}$ $I_{OH2} = -8.0\text{ mA}$	$V_{CC} - 0.5$	—	—	V	
“L” level output voltage	V_{OL1}	All port pins except PF0 to PF7	$I_{OL1} = 4.0\text{ mA}$	—	—	0.4	V	
	V_{OL2}	PF0 to PF7	$I_{OL2} = 12.0\text{ mA}$	—	—	0.4	V	
Input leakage current (High-Z output leakage current)	I_{IL}	All input pins	$V_{CC} = 3.3\text{ V}$, $V_{SS} < V_I < V_{CC}$	-5	—	+5	μA	
Open-drain output leakage current	I_{LEAK}	P40 to P46 P80 to P82 P90 to P95	—	—	—	5	μA	
Power supply current*	I_{CC}	V_{CC}	$V_{CC} = 3.3\text{ V}$, Internal operation at 16 MHz	—	37	45	mA	MB90F372/ F377
				—	30	35	mA	MB90372
	I_{CCS}		$V_{CC} = 3.3\text{ V}$, Internal operation at 16 MHz, In sleep mode	—	15	20	mA	
I_{CCL}	$V_{CC} = 3.3\text{ V}$, External 32 kHz, Internal operation at 8 kHz, In sub-clock mode, $T_A = +25\text{ }^\circ\text{C}$	—	23	80	μA			

(Continued)

MB90370/375 Series

($V_{CC} = AV_{CC} = CV_{CC} = 3.0\text{ V to }3.6\text{ V}$, $V_{SS} = AV_{SS} = CV_{SS} = 0.0\text{ V}$, $T_A = -40\text{ }^\circ\text{C to }+85\text{ }^\circ\text{C}$)

Parameter	Symbol	Pin name	Condition	Value			Unit	Remarks
				Min	Typ	Max		
Power supply current*	I _{CCLS}	V _{CC}	V _{CC} = 3.3 V, External 32 kHz, Internal operation at 8 kHz, In sub-clock sleep mode, T _A = +25 °C	—	10	50	μA	
	I _{CCWAT}		V _{CC} = 3.3 V, External 32 kHz, Internal operation at 8 kHz, In watch mode, T _A = +25 °C	—	1.5	30	μA	
	I _{CCCT}		V _{CC} = 3.3 V, Internal operation at 16 MHz, In timebase timer mode	—	1.3	2	mA	
	I _{CCCH}		V _{CC} = 3.3 V, In stop mode, T _A = +25 °C	—	1	20	μA	
Input capacitance	C _{IN}	All input pins except V _{CC} , AV _{CC} , CV _{CC} , V _{SS} , AV _{SS} , CV _{SS}	—	—	5	15	pF	
LCD divided resistance	R _{LCD}	—	Between V _{CC} and V3 at V _{CC} = 3.3 V	100	200	400	kΩ	Not for MB90F377
			Between V3 and V2 Between V2 and V1 Between V1 and V _{SS} at V _{CC} = 3.3 V	50	100	200		
COM0 to COM3 output impedance	R _{VCOM}	COM0 to COM3	V1 to V3 = 3.3 V	—	—	5	kΩ	Not for MB90F377
SEG0 to SEG8 output impedance	R _{VSEG}	SEG0 to SEG8		—	—	5	kΩ	
LCD leakage current	L _{LCDL}	V1 to V3 COM0 to COM3 SEG0 to SEG8	—	—	—	±1	μA	Not for MB90F377

(Continued)

MB90370/375 Series

(Continued)

($V_{CC} = AV_{CC} = CV_{CC} = 3.0\text{ V to }3.6\text{ V}$, $V_{SS} = AV_{SS} = CV_{SS} = 0.0\text{ V}$, $T_A = -40\text{ }^{\circ}\text{C to }+85\text{ }^{\circ}\text{C}$)

Parameter	Symbol	Pin name	Condition	Value			Unit	Remarks
				Min	Typ	Max		
Pull-up resistance	R_{UP}	P00 to P07 P10 to P17 P20 to P27 P30 to P37 \overline{RST}	—	25	50	100	$k\Omega$	
Pull-down resistance	R_{DOWN}	MD2	—	25	50	100	$k\Omega$	MB90V370, MB90372 only

* : The power supply current is measured with an external clock.

MB90370/375 Series

4. AC Characteristics

(1) Clock Timings

($V_{CC} = AV_{CC} = CV_{CC} = 3.0\text{ V to }3.6\text{ V}$, $V_{SS} = AV_{SS} = CV_{SS} = 0.0\text{ V}$, $T_A = -40\text{ }^\circ\text{C to }+85\text{ }^\circ\text{C}$)

Parameter	Symbol	Pin name	Condition	Value			Unit	Remarks
				Min	Typ	Max		
Clock frequency	F_{CH}	X0, X1	—	3	—	16	MHz	Crystal oscillator*
	F_{CH}	X0, X1		3	—	32	MHz	External clock*
	F_{CL}	X0A, X1A		—	32.768	—	kHz	
Clock cycle time	t_{HCYL}	X0, X1	—	31.25	—	333	ns	
	t_{LCYL}	X0A, X1A		—	30.5	—	μs	
Input clock pulse width	P_{WH} P_{WL}	X0	—	5	—	—	ns	Recommend duty ratio of 30% to 70%
	P_{WHL} P_{WLL}	X0A		—	15.2	—	μs	Recommend duty ratio of 30% to 70%
Input clock rise/fall time	t_{CR} t_{CF}	X0	—	—	5	ns	External clock operation	
Internal operating clock frequency	f_{CP}	—	—	1.5	—	16	MHz	Main clock operation
	f_{LCP}	—		—	8.192	—	kHz	Sub-clock operation
Internal operating clock cycle time	t_{CP}	—	—	62.5	—	666	ns	Main clock operation
	t_{LCP}	—		—	122.1	—	μs	Sub-clock operation

* : When selecting the PLL clock, the range of clock frequency is limited. Use this product within range as mentioned in "Relationship between oscillating frequency and internal operating clock frequency" of "• PLL operation guarantee range".

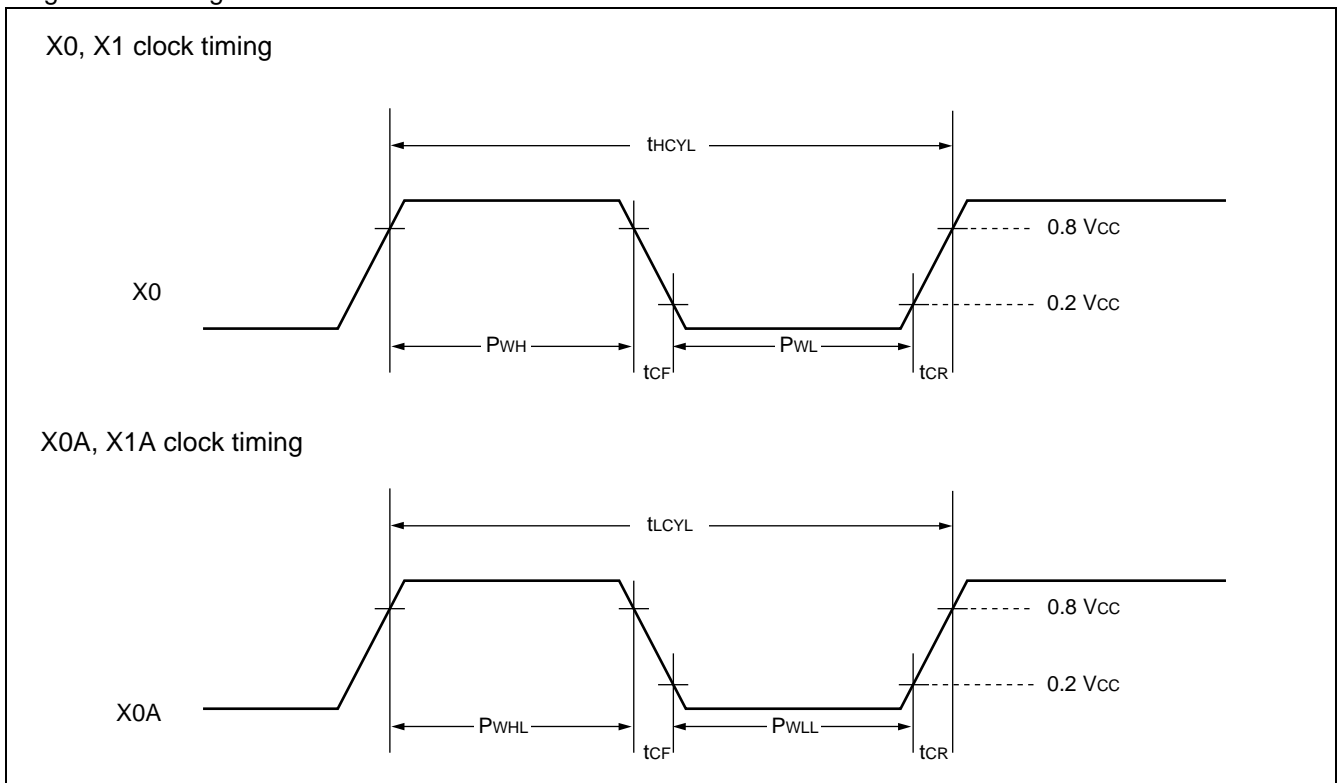

- PLL operation guarantee range

Relationship between internal operating clock frequency and power supply voltage

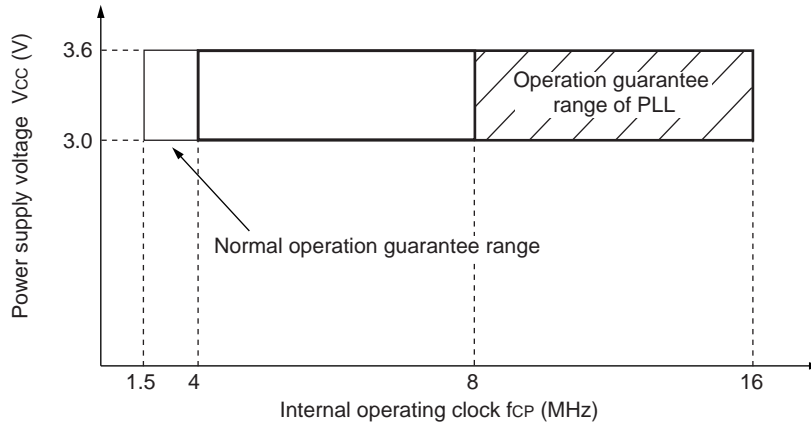

Relationship between oscillating frequency and internal operating clock frequency

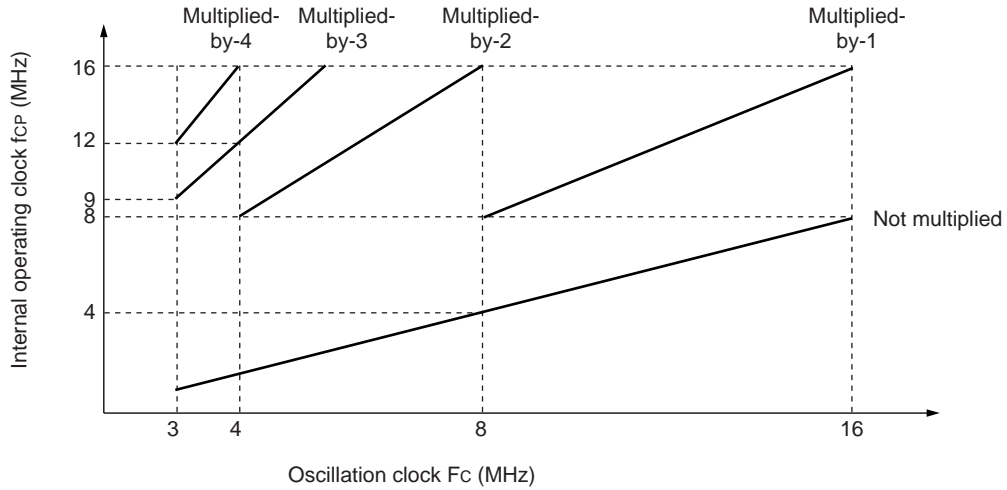

MB90370/375 Series

The AC ratings are measured for the following measurement reference voltages :

- Input signal waveform

Hysteresis input pin

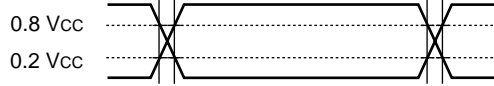

CMOS input pin



SMBus input pin

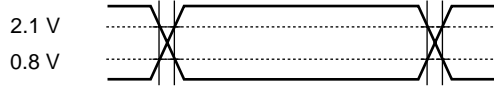

- Output signal waveform

Output pin

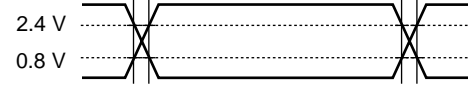

MB90370/375 Series

(2) Reset Input Timing

($V_{CC} = AV_{CC} = CV_{CC} = 3.0\text{ V to }3.6\text{ V}$, $V_{SS} = AV_{SS} = CV_{SS} = 0.0\text{ V}$, $T_A = -40\text{ }^{\circ}\text{C to }+85\text{ }^{\circ}\text{C}$)

Parameter	Symbol	Pin name	Condition	Value		Unit	Remarks
				Min	Max		
Reset input time	t_{RSTL}	$\overline{\text{RST}}$	—	16 t_{CP}	—	ns	Normal operation
				Oscillation time of oscillator* + 16 t_{CP}	—	ms	In stop mode and sub-clock mode

* : Oscillation time of oscillator is the time to reach to 90% of the oscillation amplitude from stand still. In the crystal oscillator, the oscillation time is between several ms to tens of ms. In FAR/ceramic oscillator, the oscillation time is between hundreds of μs to several ms. In the external clock, the oscillation time is 0 ms.

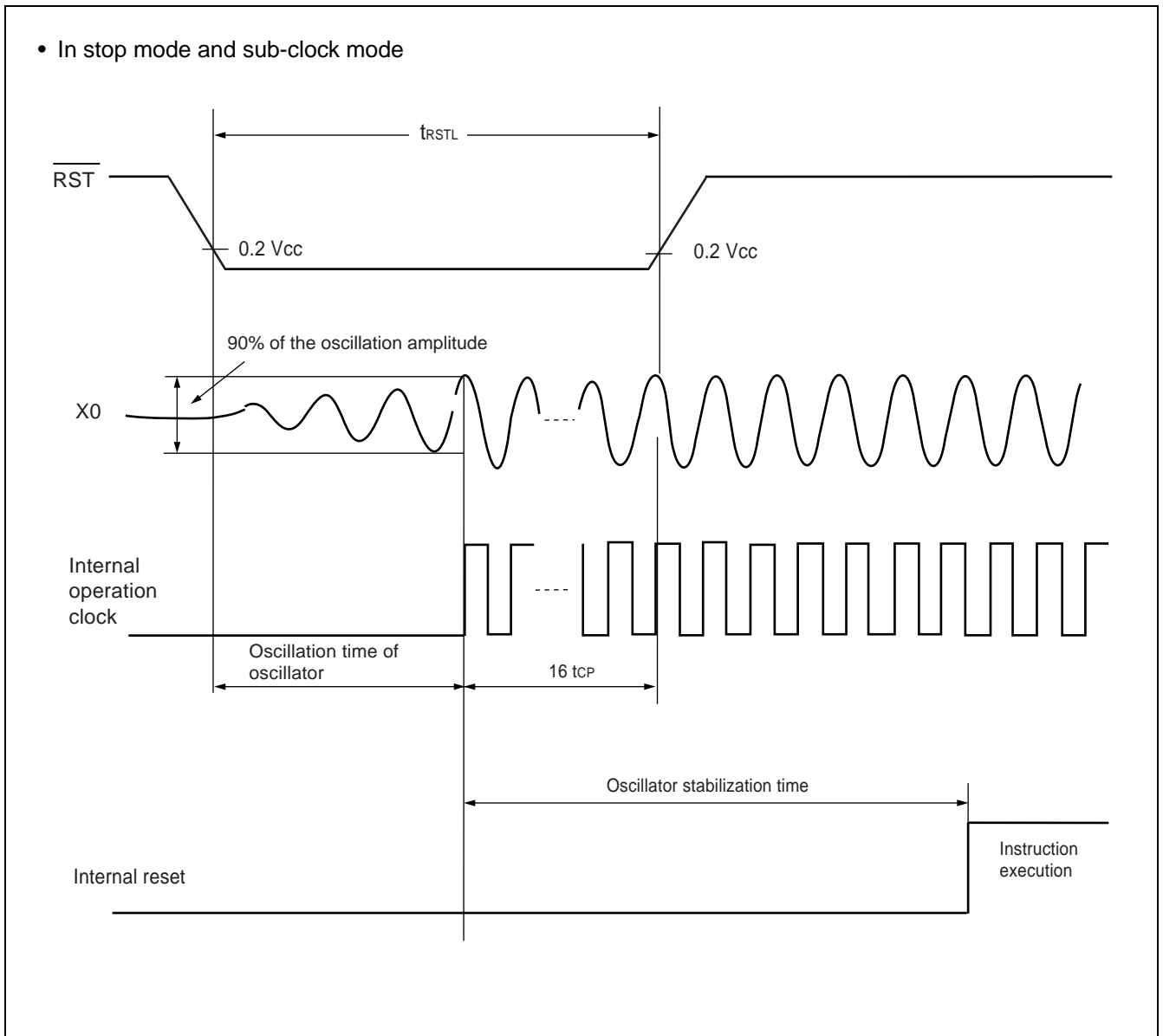

MB90370/375 Series

(3) Power-on Reset

($V_{CC} = AV_{CC} = CV_{CC} = 3.0\text{ V to }3.6\text{ V}$, $V_{SS} = AV_{SS} = CV_{SS} = 0.0\text{ V}$, $T_A = -40\text{ }^\circ\text{C to }+85\text{ }^\circ\text{C}$)

Parameter	Symbol	Pin name	Condition	Value		Unit	Remarks
				Min	Max		
Power supply rise time	t_R	V_{CC}^*	—	—	50	ms	
Power supply cut-off time	t_{OFF}	V_{CC}^*	—	1	—	ms	Due to repeated operations

* : V_{CC} must be kept lower than 0.2 V before power-on.

Notes : • The above values are used for causing a power-on reset.

Some registers in the device are initialized only upon a power-on reset. To initialize these registers, turn on the power supply using the above values.

- Make sure that power supply rises within the selected oscillation stabilization time. If the power supply voltage needs to be varied in the course of operation, a smooth voltage rise is recommended.

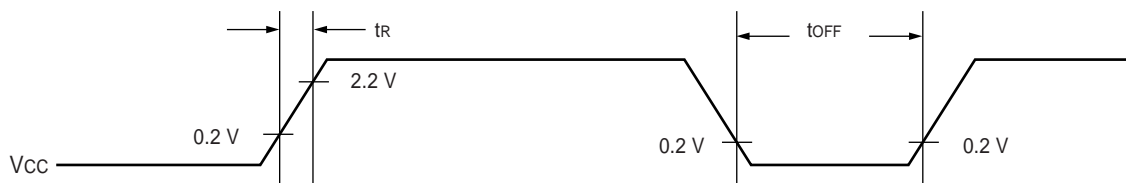

Sudden changes in the power supply voltage may cause a power-on reset.

To change the power supply voltage while the device is in operation, it is recommended to raise the voltage smoothly to suppress fluctuations as shown below. In this case, change the supply voltage with the PLL clock not used. If the voltage drop is 1 V or fewer per second, however, you can use the PLL clock.

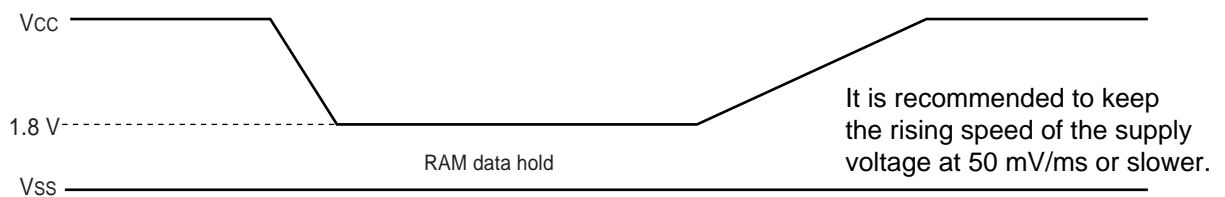

MB90370/375 Series

(4) UART1 to UART3

($V_{CC} = AV_{CC} = CV_{CC} = 3.0\text{ V to }3.6\text{ V}$, $V_{SS} = AV_{SS} = CV_{SS} = 0.0\text{ V}$, $T_A = -40\text{ }^{\circ}\text{C to }+85\text{ }^{\circ}\text{C}$)

Parameter	Symbol	Pin name	Condition	Value		Unit	Remarks
				Min	Max		
Serial clock cycle time	t_{SCYC}	UCK1 to UCK3	$C_L = 80\text{ pF} + 1\text{ TTL}$ for an output pin of internal shift clock mode	8 t_{CP}	—	ns	
UCK ↓ → UO delay time	t_{SLOV}	UCK1 to UCK3 UO1 to UO3		-80	+80	ns	
Valid UI → UCK ↑	t_{IVSH}	UCK1 to UCK3 UI1 to UI3		100	—	ns	
UCK ↑ → valid UI hold time	t_{SHIX}	UCK1 to UCK3 UI1 to UI3		t_{CP}	—	ns	
Serial clock "H" pulse width	t_{SHSL}	UCK1 to UCK3	$C_L = 80\text{ pF} + 1\text{ TTL}$ for an output pin of external shift clock mode	4 t_{CP}	—	ns	
Serial clock "L" pulse width	t_{SLSH}	UCK1 to UCK3		4 t_{CP}	—	ns	
UCK ↓ → UO delay time	t_{SLOV}	UCK1 to UCK3 UO1 to UO3		—	150	ns	
Valid UI → UCK ↑	t_{IVSH}	UCK1 to UCK3 UI1 to UI3		60	—	ns	
UCK ↑ → valid UI hold time	t_{SHIX}	UCK1 to UCK3 UI1 to UI3		60	—	ns	

- Notes :
- These are AC ratings in the CLK synchronous mode.
 - C_L is the load capacitance value connected to pins while testing.
 - t_{CP} is the internal operating clock cycle time.

MB90370/375 Series

- Internal shift clock mode

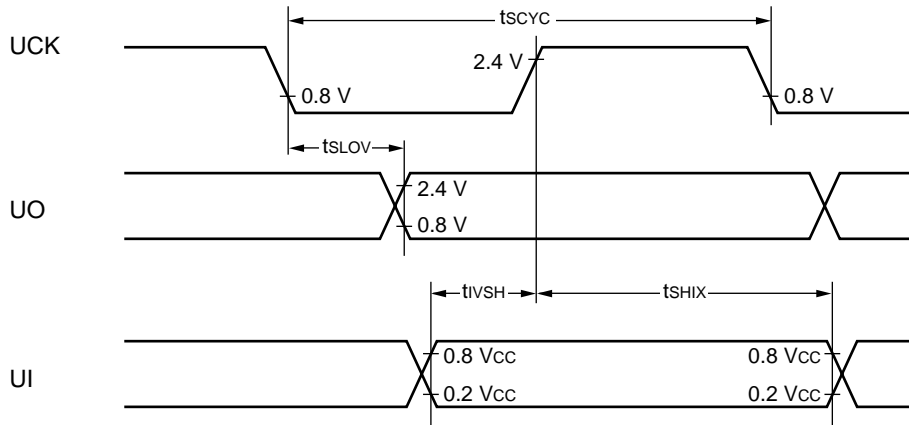

- External shift clock mode

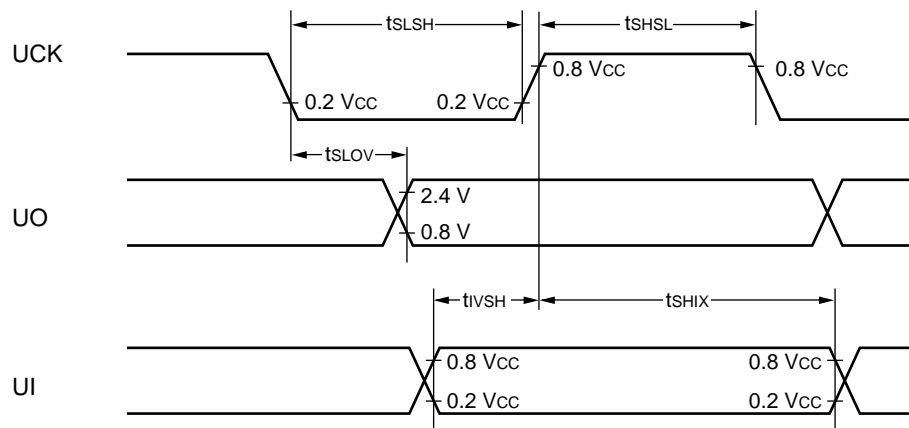

MB90370/375 Series

(5) Resources Input Timing

($V_{CC} = AV_{CC} = CV_{CC} = 3.0\text{ V to }3.6\text{ V}$, $V_{SS} = AV_{SS} = CV_{SS} = 0.0\text{ V}$, $T_A = -40\text{ }^\circ\text{C to }+85\text{ }^\circ\text{C}$)

Parameter	Symbol	Pin name	Condition	Value		Unit	Remarks
				Min	Max		
Timer input pulse width	t_{TIWH} t_{TIWL}	TIN1 to TIN4	—	4 t_{CP}	—	ns	

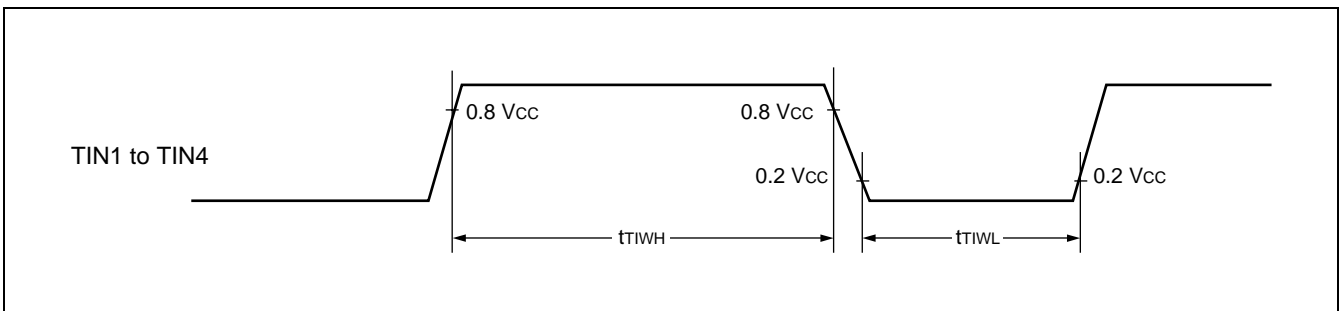

(6) Trigger Input Timing

($V_{CC} = AV_{CC} = CV_{CC} = 3.0\text{ V to }3.6\text{ V}$, $V_{SS} = AV_{SS} = CV_{SS} = 0.0\text{ V}$, $T_A = -40\text{ }^\circ\text{C to }+85\text{ }^\circ\text{C}$)

Parameter	Symbol	Pin name	Condition	Value		Unit	Remarks
				Min	Max		
Input pulse width	t_{TRGH}	ADTG	—	5 t_{CP}	—	ns	Normal operation
	t_{TRGL}	INT0 to INT5 KSI0 to KSI7		1	—	μs	Stop mode

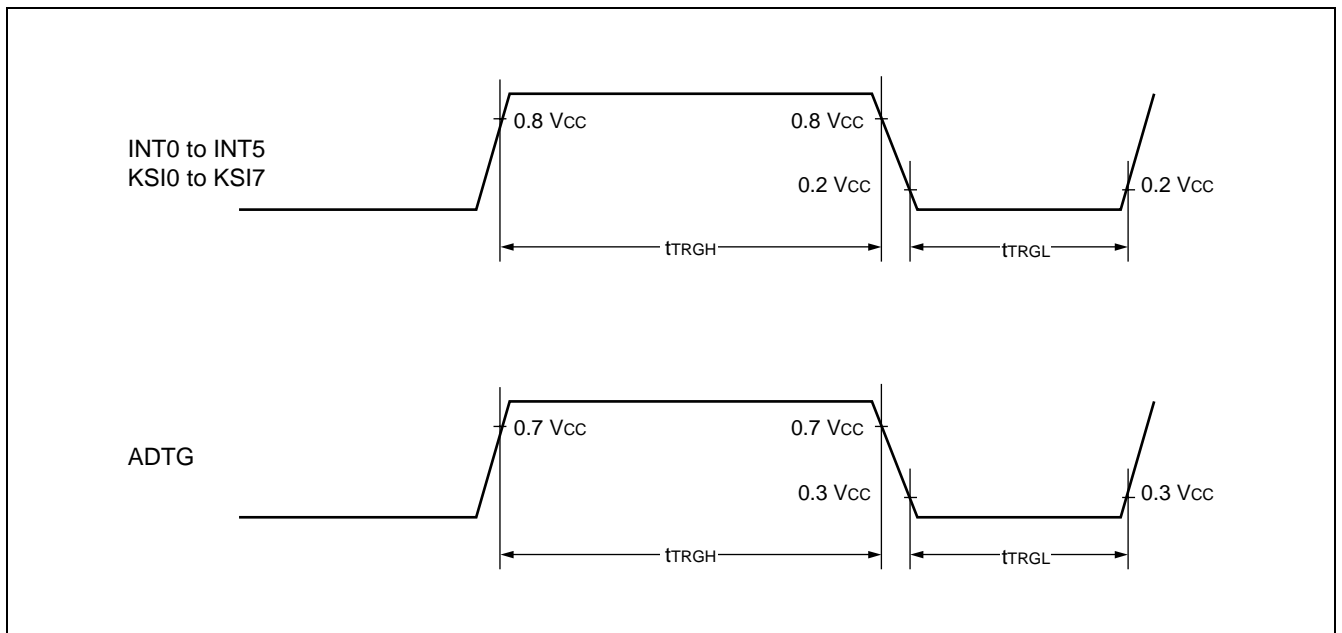

MB90370/375 Series

(7) I²C / MI²C Timing

(V_{CC} = AV_{CC} = CV_{CC} = 3.0 V to 3.6 V, V_{SS} = AV_{SS} = CV_{SS} = 0.0 V, T_A = -40 °C to +85 °C)

Parameter	Symbol	Pin name	Value		Unit	Remarks
			Min	Max		
Start condition output	t _{STA}	SCL SDA	t _{CP} (m × n/2 - 1) - 20	t _{CP} (m × n/2 - 1) + 20	ns	Master mode
Stop condition output	t _{STO}	SCL SDA	t _{CP} (m × n/2 + 3) - 20	t _{CP} (m × n/2 + 3) + 20	ns	Master mode
Start condition detect	t _{STA}	SCL SDA	t _{CP} + 40	—	ns	
Stop condition detect	t _{STO}	SCL SDA	t _{CP} + 40	—	ns	
Restart condition output	t _{STASU}	SCL SDA	t _{CP} (m × n/2 + 3) - 20	t _{CP} (m × n/2 + 3) + 20	ns	Master mode
Restart condition detect	t _{STASU}	SCL SDA	t _{CP} + 40	—	ns	
SCL output "L" width	t _{LOW}	SCL	t _{CP} × m × n/2 - 20	t _{CP} × m × n/2 + 20	ns	Master mode
SCL output "H" width	t _{HIGH}	SCL	t _{CP} (m × n/2 + 2) - 20	t _{CP} (m × n/2 + 2) + 20	ns	Master mode
SDA output delay	t _{DO}	SDA	t _{CP} × 3 - 20	t _{CP} × 3 + 20	ns	
SDA output setup time after interrupt	t _{DOSU} *3	SDA	t _{CP} × m × n/2 - 20	—	ns	*1
			t _{CP} × 4 - 20	—	ns	*2
SCL input "L" pulse	t _{LOW}	SCL	t _{CP} × 3 + 40	—	ns	
SCL input "H" pulse	t _{HIGH}	SCL	t _{CP} + 40	—	ns	
SDA output setup time	t _{SU}	SDA	40	—	ns	
SDA hold time	t _{HO}	SDA	0	—	ns	

*1 : At the stop condition or transferring of next byte.

*2 : After setting register bit IBCRH : SCC/MBCRH : SCC at restart.

*3 : t_{DOSU} is longer than the "L" width of SCL.

Notes : • t_{CP} is the internal operating clock cycle time.

- m is the setting bit of shift clock oscillation defined in the "ICCR register (CS4 to CS3)" and "MCCR register (CS4 to CS3)". Please refer to the MB90370/375 series H/W manual for details.
- n is the setting bit of shift clock oscillation defined in the "ICCR register (CS2 to CS0)" and "MCCR register (CS2 to CS0)". Please refer to the MB90370/375 series H/W manual for details.
- SDA and SCL output value is specified on condition that the rise/fall time is "0 ns".

MB90370/375 Series

- Data transmit (master / slave)

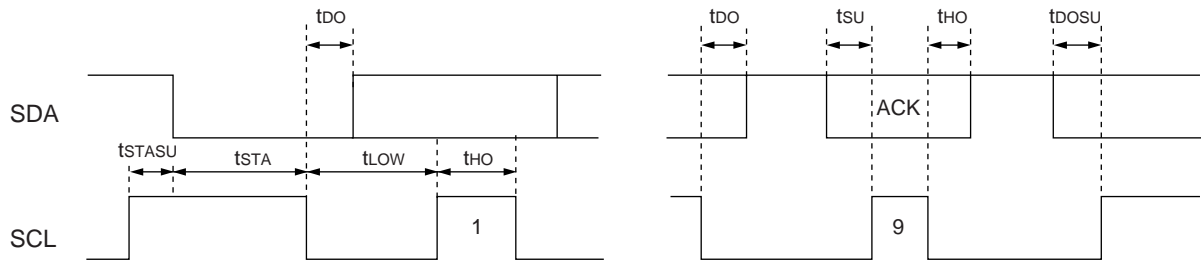

- Data receive (master / slave)

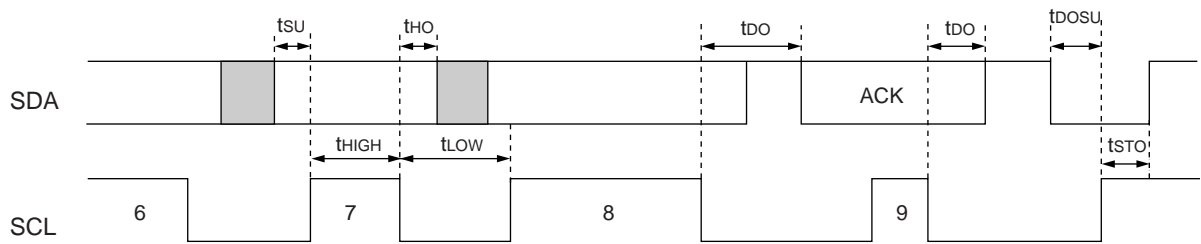

MB90370/375 Series

(8) PS/2 Interface Timing

($V_{CC} = AV_{CC} = CV_{CC} = 3.0\text{ V to }3.6\text{ V}$, $V_{SS} = 0.0\text{ V}$, $T_A = -40\text{ }^\circ\text{C to }+85\text{ }^\circ\text{C}$)

Parameter	Symbol	Pin name	Condition	Value			Unit	Remarks
				Min	Typ	Max		
PSCK clock cycle time	t_{PCYC}	PSCK0 to PSCK2 PSDA0 to PSDA2	—	$4 t_{CP}$	—	—	ns	
PSCK $\downarrow \rightarrow$ PSDA	t_{PLOW}	PSCK0 to PSCK2 PSDA0 to PSDA2	Transmission Mode	$2 t_{CP}$	—	—	ns	
Valid PSDA \rightarrow PSCK \downarrow	t_{PIVSH}	PSCK0 to PSCK2 PSDA0 to PSDA2	Reception Mode	$1 t_{CP}$	—	—	ns	
PSCK $\downarrow \rightarrow$ valid PSDA hold time	t_{PHIX}	PSCK0 to PSCK2 PSDA0 to PSDA2		$1 t_{CP}$	—	—	ns	
PSCK clock "H" pulse width	t_{PHSL}	PSCK0 to PSCK2 PSDA0 to PSDA2	—	$2 t_{CP}$	—	—	ns	
PSCK clock "L" pulse width	t_{PLSH}	PSCK0 to PSCK2 PSDA0 to PSDA2		$2 t_{CP}$	—	—	ns	

Note : t_{CP} is the internal operating clock cycle time.

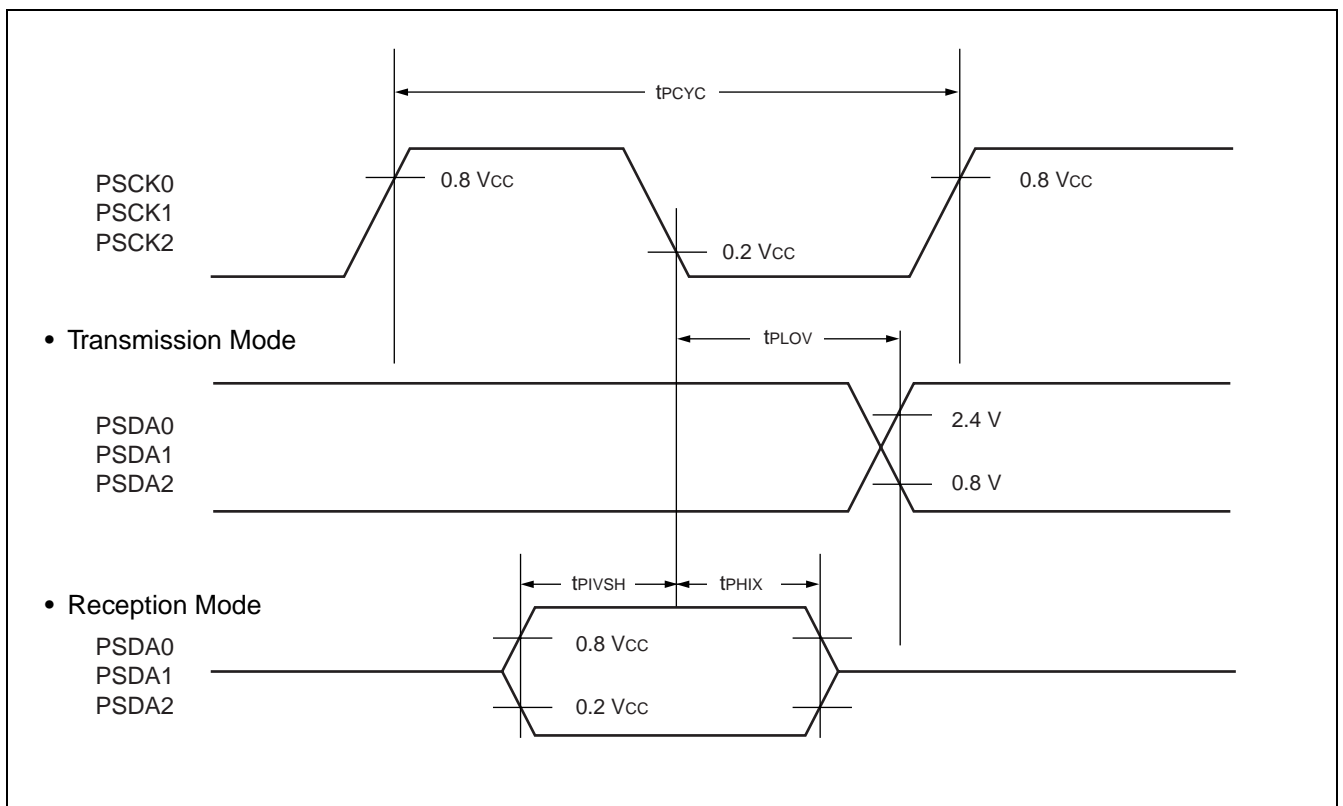

MB90370/375 Series

(9) LPC Timing

($V_{CC} = AV_{CC} = CV_{CC} = 3.0\text{ V to }3.6\text{ V}$, $V_{SS} = AV_{SS} = CV_{SS} = 0.0\text{ V}$, $T_A = -40\text{ }^{\circ}\text{C to }+85\text{ }^{\circ}\text{C}$)

Parameter	Symbol	Pin name	Condition	Value			Unit	Remarks
				Min	Typ	Max		
LCLK cycle time	t_{CYCLE}	—	—	30	—	—	ns	
LCLK high time	t_{HIGH}	—	—	12	—	—	ns	
LCLK low time	t_{LOW}	—	—	12	—	—	ns	

LCLK AC timing

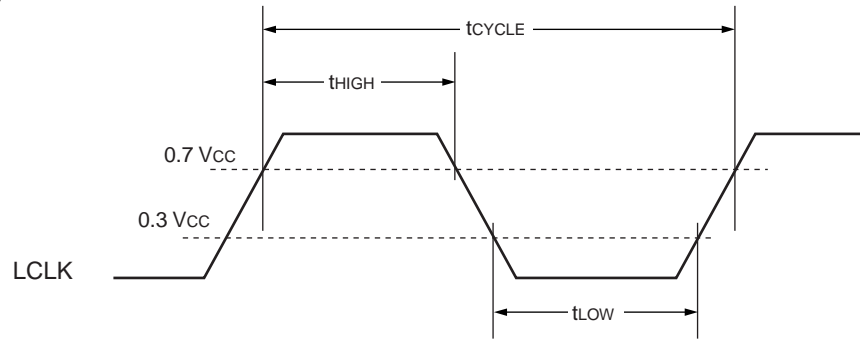

MB90370/375 Series

LAD, $\overline{\text{LFRAME}}$, GA20 AC timing

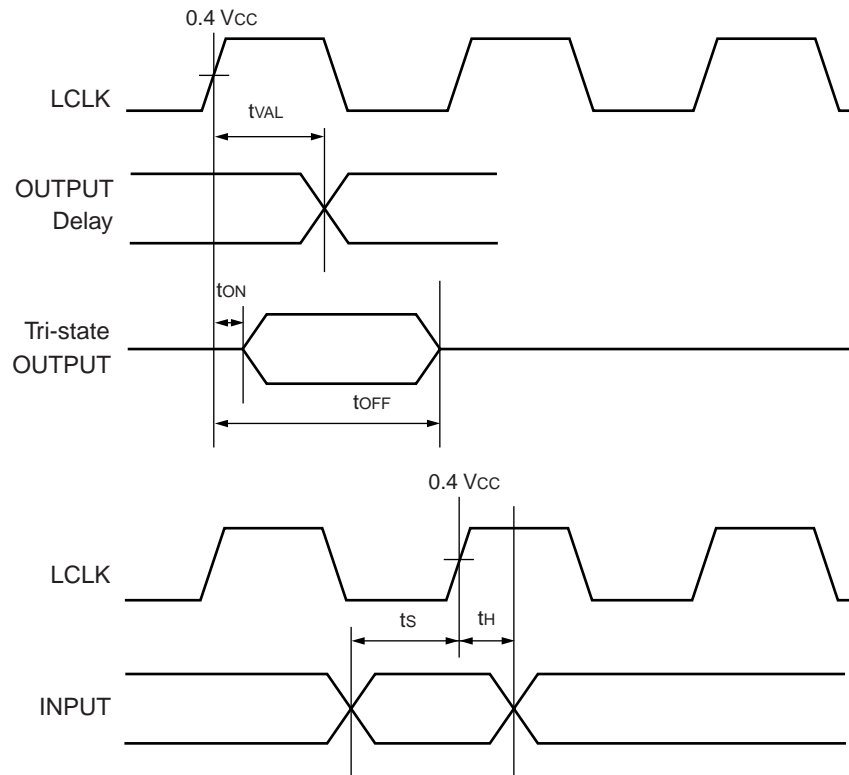

MB90370/375 Series

5. A/D Converter Electrical Characteristics

($2.7\text{ V} \leq \text{AVR} - \text{AV}_{\text{SS}}, \text{V}_{\text{CC}} = \text{AV}_{\text{CC}} = \text{CV}_{\text{CC}} = 3.0\text{ V}$ to 3.6 V , $\text{V}_{\text{SS}} = \text{AV}_{\text{SS}} = \text{CV}_{\text{SS}} = 0.0\text{ V}$, $T_{\text{A}} = -40\text{ }^{\circ}\text{C}$ to $+85\text{ }^{\circ}\text{C}$)

Parameter	Symbol	Pin name	Value			Unit	Remarks
			Min	Typ	Max		
Resolution	—	—	—	—	10	bit	
Total error	—	—	—	—	± 3.0	LSB	
Non-linear error	—	—	—	—	± 2.5	LSB	
Differential linearity error	—	—	—	—	± 1.9	LSB	
Zero transition voltage	V_{OT}	AN0 to AN11	$\text{AV}_{\text{SS}} - 1.5\text{ LSB}$	$\text{AV}_{\text{SS}} + 0.5\text{ LSB}$	$\text{AV}_{\text{SS}} + 5.5\text{ LSB}$	mV	For MB90V370
					$\text{AV}_{\text{SS}} + 2.5\text{ LSB}$		For MB90F372/F377/372
Full-scale transition voltage	V_{FST}	AN0 to AN11	$\text{AVR} - 3.5\text{ LSB}$	$\text{AVR} - 1.5\text{ LSB}$	$\text{AVR} + 0.5\text{ LSB}$	mV	
Conversion time	—	—	3.1	—	—	μs	Actual value is specified as a sum of values specified in ADCR0 : CT1, CT0 and ADCR0 : ST1, ST0. Be sure that the setting value is greater than the Min value.
Sampling period	—	—	2	—	—	μs	Actual value is specified in ADCR0 : ST1, ST0 bits. Be sure that the setting value is greater than the Min value.
Analog port input current	I_{AIN}	AN0 to AN11	—	0.1	10	μA	
Analog input voltage	V_{AIN}	AN0 to AN11	AV_{SS}	—	AVR	V	
Reference voltage	—	AVR	$\text{AV}_{\text{SS}} + 2.7$	—	AV_{CC}	V	
Power supply current	I_{A}	AV_{CC}	—	1.4	6.4	mA	
	I_{AH}		—	—	5	μA	*
Reference voltage supply current	I_{R}	AVR	—	94	300	μA	
	I_{RH}		—	—	5	μA	*
Offset between channels	—	AN0 to AN11	—	—	4	LSB	

* : The current when the A/D converter is not operating or the CPU is in stop mode (for $\text{V}_{\text{CC}} = \text{AV}_{\text{CC}} = \text{AVR} = 3.0\text{ V}$) .

MB90370/375 Series

6. A/D Converter Glossary

- Resolution : Analog changes that are identifiable with the A/D converter.
- Linearity error : The deviation of the straight line connecting the zero transition point (“00 0000 0000” ↔ “00 0000 0001”) with the full-scale transition point (“11 1111 1110” ↔ “11 1111 1111”) from actual conversion characteristics.
- Differential linearity error : The deviation of input voltage needed to change the output code by 1 LSB from the theoretical value.
- Total error : The total error is defined as a difference between the actual value and the theoretical value, which includes zero-transition error/full-scale transition error and linearity error.

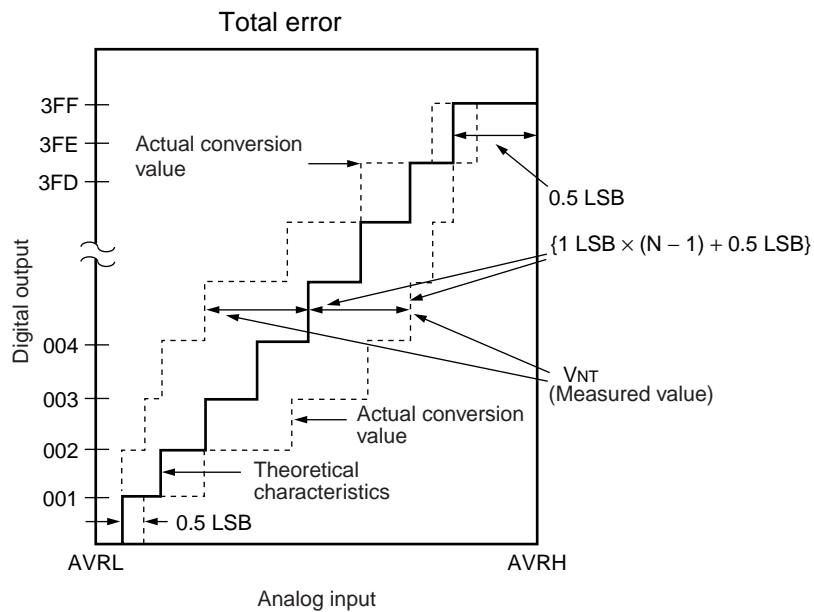

$$\text{Total error for digital output } N = \frac{V_{NT} - \{1 \text{ LSB} \times (N - 1) + 0.5 \text{ LSB}\}}{1 \text{ LSB}} \quad [\text{LSB}]$$

$$1 \text{ LSB} = (\text{Theoretical value}) \frac{AVR - AV_{SS}}{1024} \quad [\text{V}]$$

$$V_{OT} (\text{Theoretical value}) = AV_{SS} + 0.5 \text{ LSB} \quad [\text{V}]$$

$$V_{FST} (\text{Theoretical value}) = AVR - 1.5 \text{ LSB} \quad [\text{V}]$$

V_{NT} : Voltage at a transition of digital output from (N - 1) to N

(Continued)

(Continued)

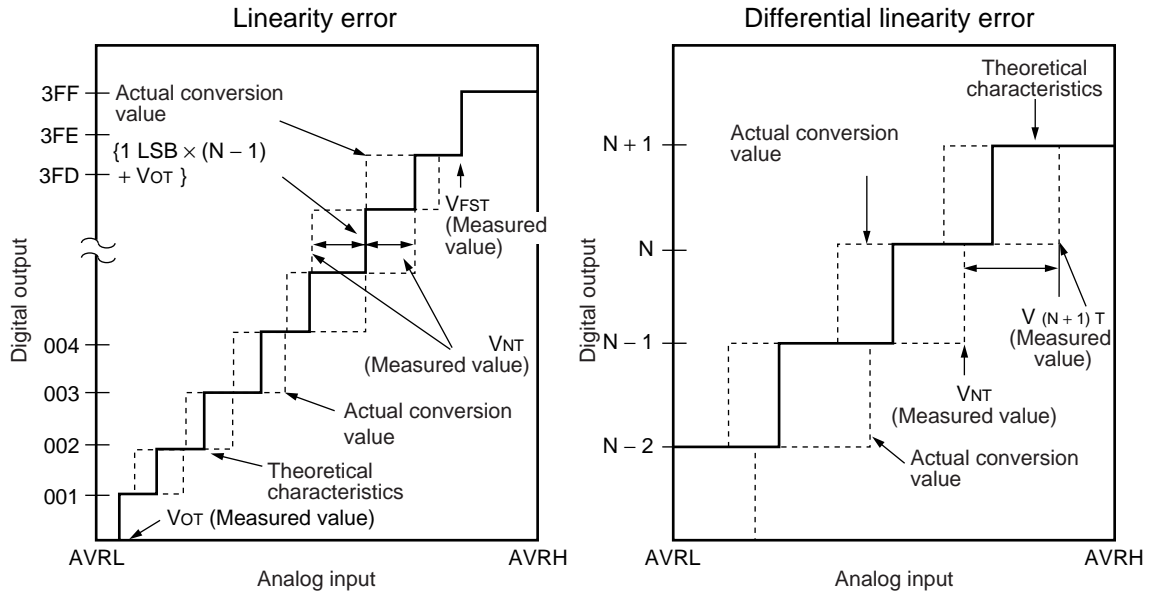

$$\text{Linearity error of digital output N} = \frac{V_{NT} - \{1 \text{ LSB} \times (N - 1) + V_{OT}\}}{1 \text{ LSB}} \quad [\text{LSB}]$$

$$\text{Differential linearity error of digital output N} = \frac{V_{(N+1)T} - V_{NT}}{1 \text{ LSB}} - 1 \quad [\text{LSB}]$$

$$1 \text{ LSB} = \frac{V_{FST} - V_{OT}}{1022} \quad [\text{V}]$$

V_{OT} : Voltage at transition of digital output from "000_H" to "001_H"

V_{FST} : Voltage at transition of digital output from "3FE_H" to "3FF_H"

MB90370/375 Series

7. Notes on Using A/D Converter

Select the output impedance value for the external circuit of analog input according to the following conditions. Output impedance values of the external circuit of 4 kΩ or lower are recommended.

When capacitors are connected to external pins, the capacitance of several thousand times the internal capacitor value is recommended to minimized the effect of voltage distribution between the external capacitor and internal capacitor.

When the output impedance of the external circuit is too high, the sampling period for analog voltages may not be sufficient.

- Equipment of analog input circuit model

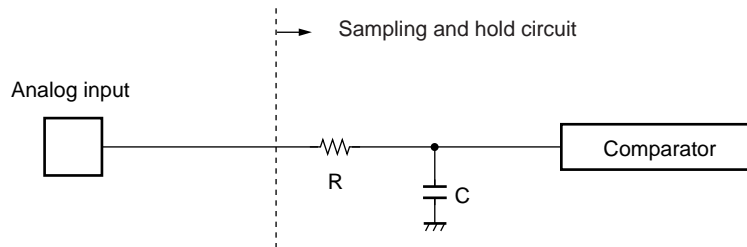

R : about 1.9 kΩ
C : about 32.3 pF

Note : Listed values must be considered as standards.

- Error

The smaller the $|AVR - AV_{SS}|$ is, the greater the error would become relatively.

8. D/A Electrical Characteristics

($V_{CC} = AV_{CC} = CV_{CC} = 3.0\text{ V to }3.6\text{ V}$, $V_{SS} = AV_{SS} = CV_{SS} = 0.0\text{ V}$, $T_A = -40\text{ °C to }+85\text{ °C}$)

Parameter	Symbol	Pin name	Condition	Value			Unit	Remarks
				Min	Typ	Max		
Resolution	—	—	—	—	8	—	bit	
Differential linearity error	—	—		—	—	±0.9	LSB	
Non-linearity error	—	—		—	—	±1.5	LSB	
Conversion time	—	—		—	0.6	—	μs	*
Analog output impedance	—	—		2.0	2.9	3.8	kΩ	
Power supply	I_{DVR}	AV_{CC}		—	—	460	μA	
Current	I_{DVRs}	AV_{CC}		—	0.1	—	μA	D/A stops

* : With load capacitance is 20 pF.

MB90370/375 Series

9. Comparator Electrical Characteristics

($V_{CC} = AV_{CC} = CV_{CC} = 3.3\text{ V to }3.6\text{ V}$, $V_{SS} = AV_{SS} = CV_{SS} = 0.0\text{ V}$, $T_A = -40\text{ °C to }+85\text{ °C}$)

Parameter	Symbol	Pin name	Condition	Value			Unit	Remarks
				Min	Typ	Max		
Reference voltage	—	CVRH2	—	1.1	—	2.9	V	*
		CVRH1		CVRL	—	2.9	V	
		CVRL		1.1	—	CVRH1	V	
Reference voltage supply current	I_{CR}	CVRH2 CVRH1 CVRL	—	—	—	± 1	μA	
Comparator supply current	I_{CV}	CV _{CC}	—	—	—	50	μA	active
				—	—	10	μA	inactive
Analog input voltage	V_{IH}	DCIN DCIN2 VOL1 to VOL3 VSI1 to VSI3	—	CV _{SS}	—	CV _{CC}	V	

*: Please use the reference voltage of CVRH2, CVRH1 and CVRL to $0.5V_{CC}$ for MB90F377.

10. Serial IRQ Electrical Characteristics

($V_{CC} = AV_{CC} = CV_{CC} = 3.0\text{ V to }3.6\text{ V}$, $V_{SS} = AV_{SS} = CV_{SS} = 0.0\text{ V}$, $T_A = -40\text{ °C to }+85\text{ °C}$)

Parameter	Symbol	Pin name	Condition	Value			Unit	Remarks
				Min	Typ	Max		
"H" level input voltage	V_{IH}	—	—	$0.7V_{CC}$	—	V_{CC}	V	
"L" level input voltage	V_{IL}	—	—	V_{SS}	—	$0.3V_{CC}$	V	
"H" level output voltage	V_{OH}	—	—	$V_{CC} - 0.5$	—	—	V	
"L" level output voltage	V_{OL}	—	—	—	—	0.4	V	

11. Flash Memory Program/Erase Characteristics

Parameter	Condition	Value			Unit	Remarks
		Min	Typ	Max		
Sector erase time	$T_A = +25\text{ °C}$ $V_{CC} = 3.0\text{ V}$	—	1	15	s	Excludes 00H programming prior to erasure
Chip erase time		—	4	—	s	Excludes 00H programming prior to erasure
Word (16 bit width) programming time		—	16	3,600	μs	Except for the over head time of the system
Program/Erase cycle	—	10,000	—	—	cycle	

MB90370/375 Series

EXAMPLE CHARACTERISTICS

- MB90F372

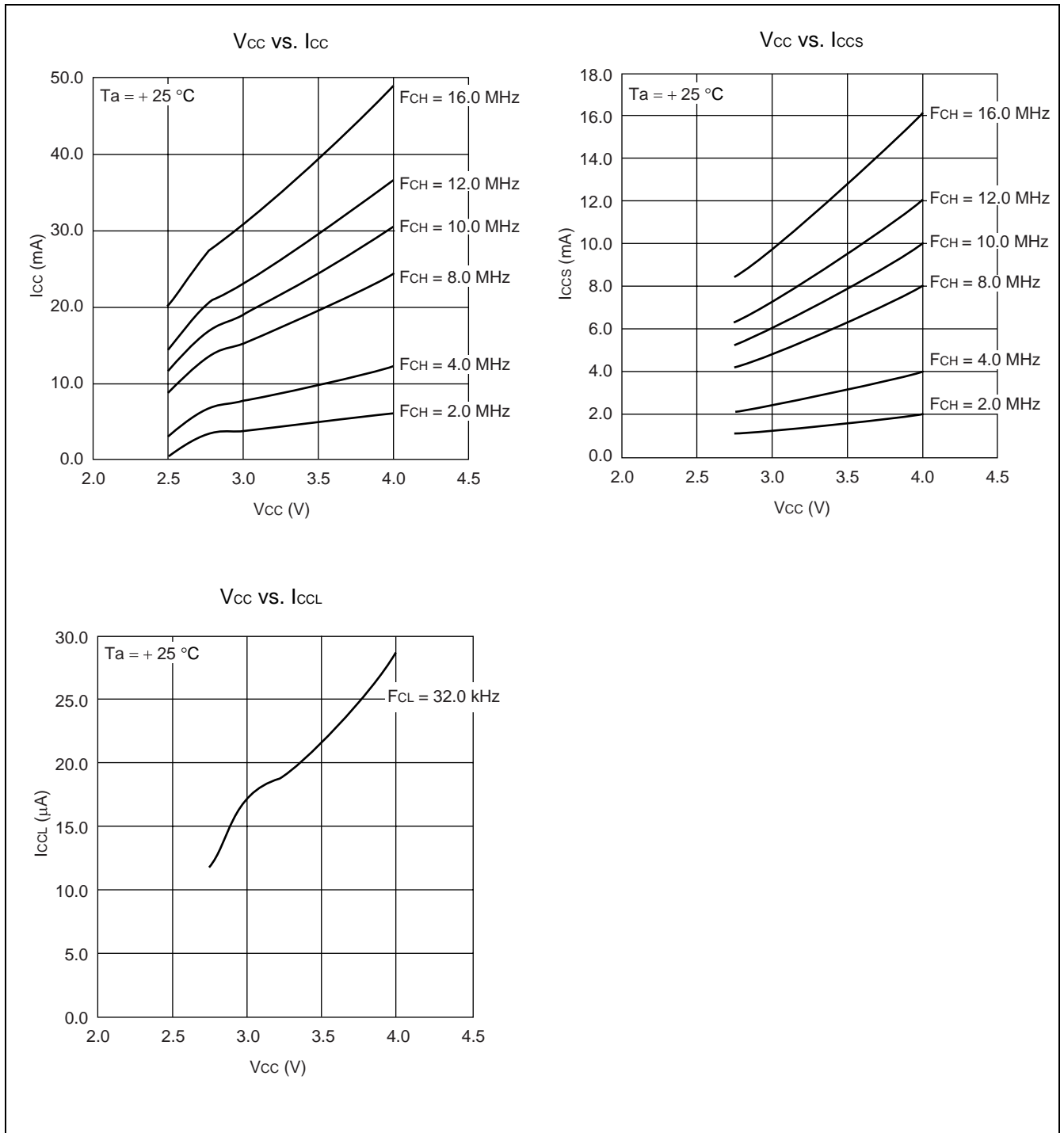

(Continued)

MB90370/375 Series

(Continued)

I_{OH1} vs. $V_{CC} - V_{OH1}$

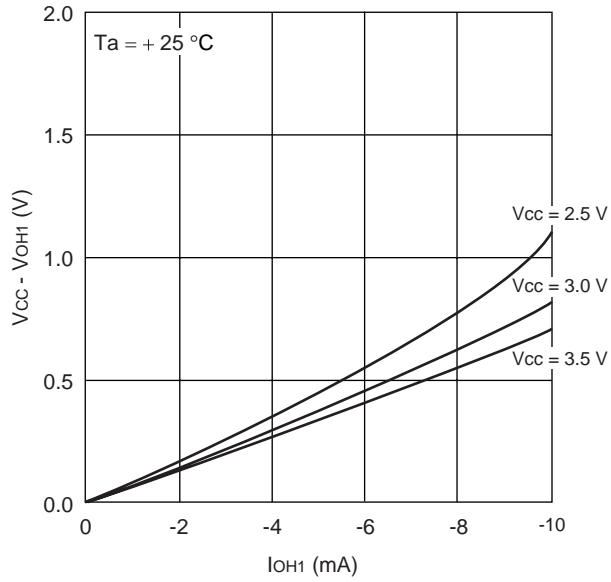

I_{OH2} vs. $V_{CC} - V_{OH2}$

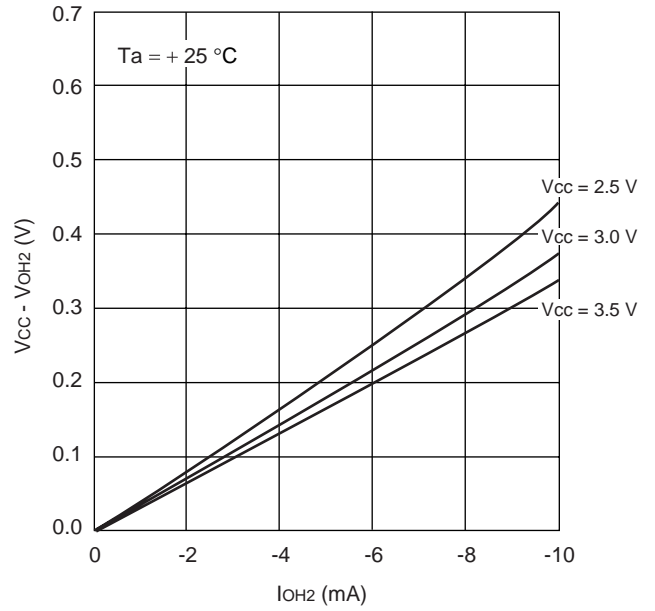

I_{OL1} vs. V_{OL1}

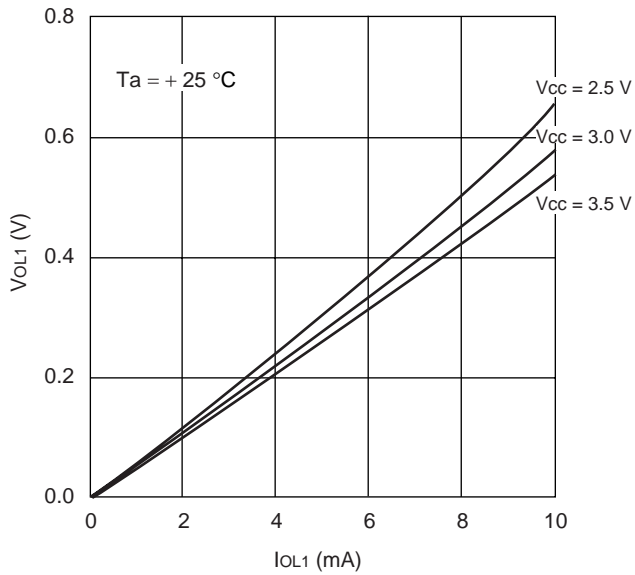

I_{OL2} vs. V_{OL2}

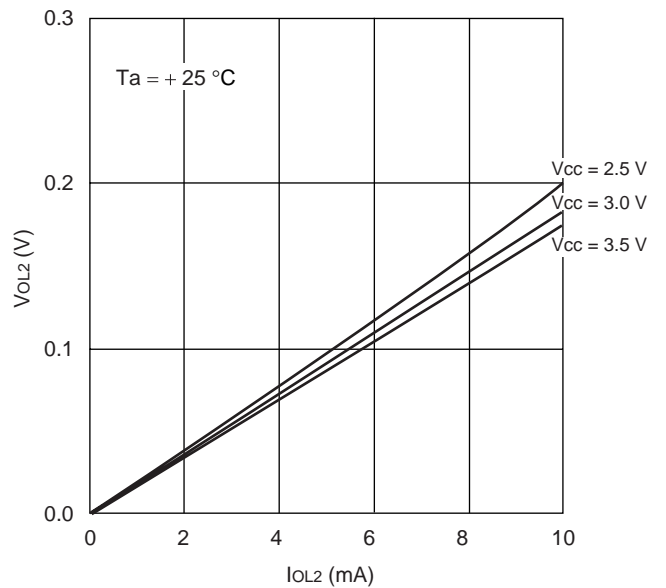

MB90370/375 Series

- MB90372t

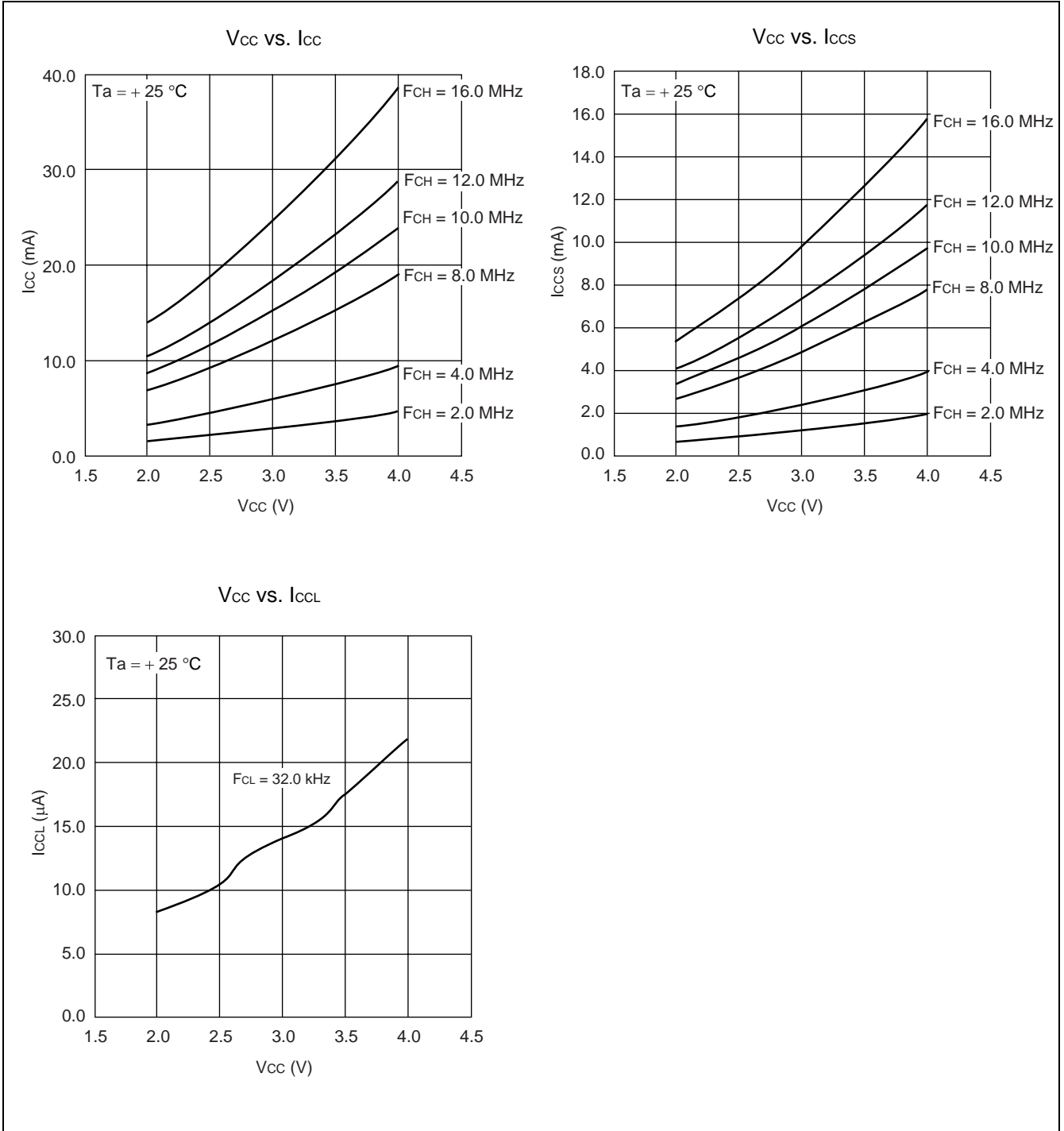

(Continued)

MB90370/375 Series

(Continued)

I_{OH1} vs. $V_{CC} - V_{OH1}$

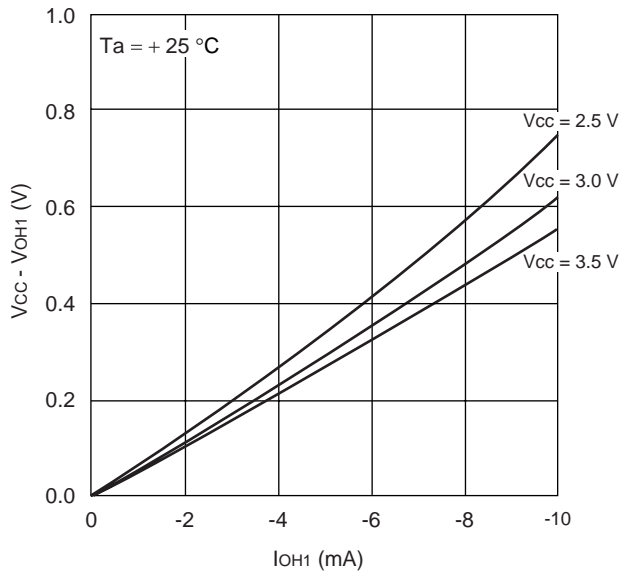

I_{OH2} vs. $V_{CC} - V_{OH2}$

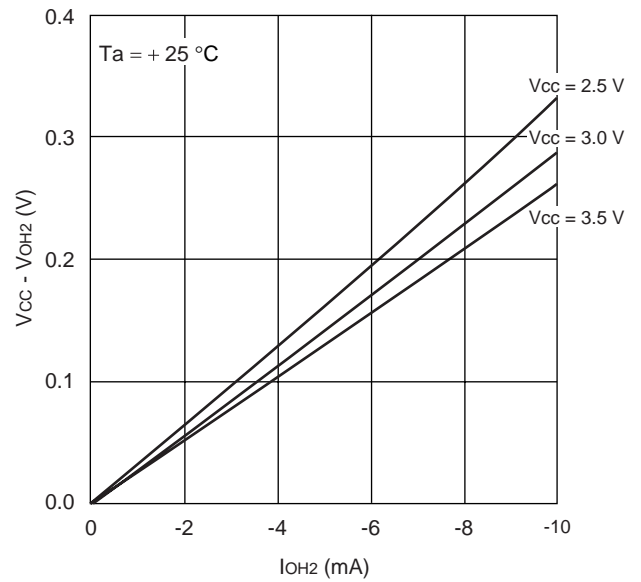

I_{OL1} vs. V_{OL1}

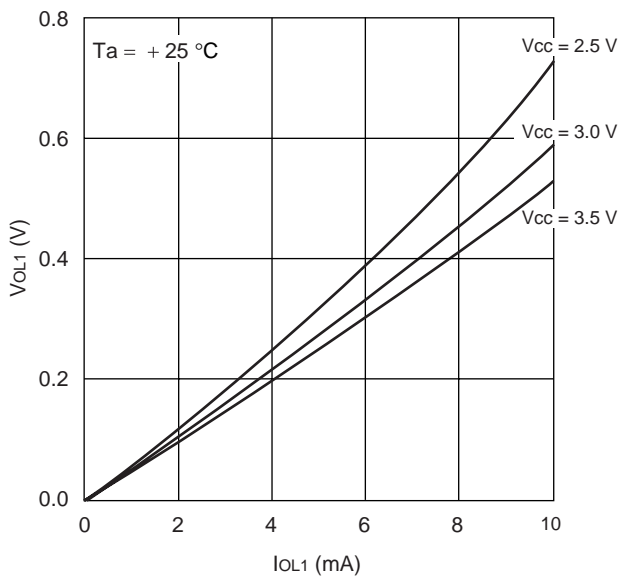

I_{OL2} vs. V_{OL2}

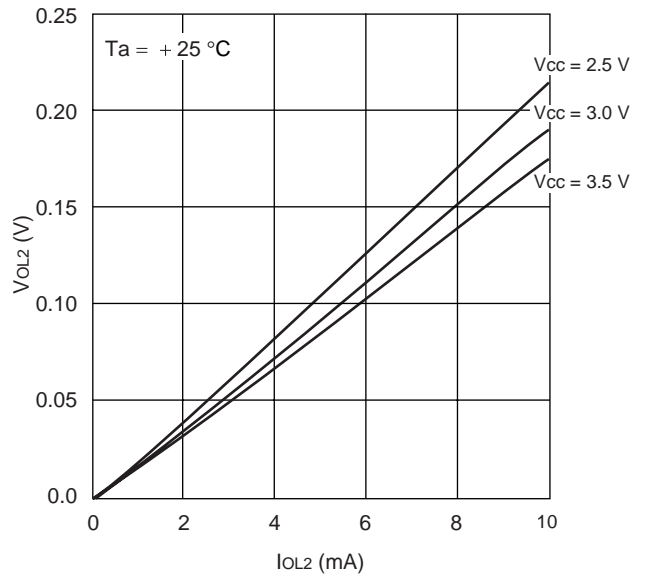

MB90370/375 Series

■ ORDERING INFORMATION

Part number	Package	Remarks
MB90F372PFF-G MB90F377PFF-G MB90372PFF-G-XXX	144-pin Plastic LQFP (FPT-144P-M12)	XXX is the ROM release number.

MB90370/375 Series

FUJITSU LIMITED

All Rights Reserved.

The contents of this document are subject to change without notice. Customers are advised to consult with FUJITSU sales representatives before ordering.

The information, such as descriptions of function and application circuit examples, in this document are presented solely for the purpose of reference to show examples of operations and uses of Fujitsu semiconductor device; Fujitsu does not warrant proper operation of the device with respect to use based on such information. When you develop equipment incorporating the device based on such information, you must assume any responsibility arising out of such use of the information. Fujitsu assumes no liability for any damages whatsoever arising out of the use of the information.

Any information in this document, including descriptions of function and schematic diagrams, shall not be construed as license of the use or exercise of any intellectual property right, such as patent right or copyright, or any other right of Fujitsu or any third party or does Fujitsu warrant non-infringement of any third-party's intellectual property right or other right by using such information. Fujitsu assumes no liability for any infringement of the intellectual property rights or other rights of third parties which would result from the use of information contained herein.

The products described in this document are designed, developed and manufactured as contemplated for general use, including without limitation, ordinary industrial use, general office use, personal use, and household use, but are not designed, developed and manufactured as contemplated (1) for use accompanying fatal risks or dangers that, unless extremely high safety is secured, could have a serious effect to the public, and could lead directly to death, personal injury, severe physical damage or other loss (i.e., nuclear reaction control in nuclear facility, aircraft flight control, air traffic control, mass transport control, medical life support system, missile launch control in weapon system), or (2) for use requiring extremely high reliability (i.e., submersible repeater and artificial satellite).

Please note that Fujitsu will not be liable against you and/or any third party for any claims or damages arising in connection with above-mentioned uses of the products.

Any semiconductor devices have an inherent chance of failure. You must protect against injury, damage or loss from such failures by incorporating safety design measures into your facility and equipment such as redundancy, fire protection, and prevention of over-current levels and other abnormal operating conditions.

If any products described in this document represent goods or technologies subject to certain restrictions on export under the Foreign Exchange and Foreign Trade Law of Japan, the prior authorization by Japanese government will be required for export of those products from Japan.

F0402

© FUJITSU LIMITED Printed in Japan