

STRUCTURE	Silicon Monolithic Integrated Circuit
PRODUCT NAME	Dual Synchronous DC/DC converter controller
TYPE	<b>BD9011EKN</b>
FEATURES	<ul style="list-style-type: none"> <li>• Wide Input Range</li> <li>• High Precision Reference Voltage</li> <li>• Built-in over current protect with OFF latch and Auto remove</li> <li>• Adjustable Frequency with synchronous function</li> </ul>

## ○ABSOLUTE MAXIMUM RATINGS (Ta=25°C)

Symbol	Limits	Unit	Symbol	Limits	Unit
EXTVCC	34 *1	V	VREG33	VREG5	V
VCCCL1,2	34 *1	V	SS1,2,FB1,2		
CL1,2	34	V	COMP1,2		
SW1,2	34 *1	V	DET1,2		
BOOT1,2	40 *1	V	RT, SYNC		
BOOT1,2-SW1,2	7 *1	V	Power Dissipatio	0.875 *2	W
STB, EN1,2	VCC	V	Operating Temperature Range	-40~+105	°C
VREG5,5A	7	V	Storage Temperature Range	-55~+150	°C
			Maximum Junction Temperature	+150	°C

(1) Do not however exceed Pd.

(2) Pd derated at 7mW/°C for temperature above Ta=25°C, Mounted on PCB 70mm×70mm×1.6mm.

## ○OPERATING CONDITIONS (Ta=25°C)

Parameter	Symbol	Min	Max	Unit
Supply Voltage 1	EXTVCC1	3.9	30	V
Supply Voltage 2	VCC1	3.9	30	V
Recommend Supply Voltage 1	EXTVCC2	6	24	V
Recommend Supply Voltage 2	VCC2	6	24	V
BOOT—SW Voltage	BOOT—SW	4.5	VREG5	V
Oscillator Frequency	OSC	250	550	kHz
Synchronizing Frequency	SYNC	OSC	550	kHz

※Electrical characteristics are not guaranteed (especially when operating on reduce voltage)

\*The product described in this specification is a strategic product (and/or service) subject to COCOM regulations. It should not be exported without authorization from the appropriate government.

\*This product is not designed for normal operation within a radio active environment.

\*Status of this document

The Japanese version of this document is the formal specification.

A customer may use this translation version only for a reference to help reading the formal version.

If there are any differences in translation version of this document, formal version takes priority.

○ELECTRICAL CHARACTERISTICS (Unless otherwise specified, Ta=25°C VCC/EXTVCC=12V STB=5V EN1,2=5V)

Parameter	Symbol	Limit			Unit	Conditions	Test Circuit
		Min	Typ	Max			
VIN Bias Current	IIN	-	5	10	mA		
Stand-by Current	IST	-	0	10	μA	VSTB=0V	
STB Low Voltage	Vstblow	GND	-	1.0	V		
STB High Voltage	Vstbhigh	2.0	-	Vcc	V		
STB input Voltage	Istb	10	20	30	μA	VSTB=5V	
[VREG5]							
Output Voltage	VREG5	4.8	5	5.2	V	IREF=6mA	
Peak Output Current	IREG5_MAX	10	-	-	mA		
Line Regulation	VREG5_I	-	10	50	mV	VIN=7.5 to 25V	
Load Regulation	VREG5_L	-	10	50	mV	IREF=0 to 6mA	
[VREG33]							
Output Voltage	VREG33	3.0	3.3	3.6	V	IREF=6mA	
Peak Output Current	IREG33_MAX	10	-	-	mA		
Line Regulation	VREG33_I	-	10	50	mV	VIN=7.5 to 25V	
Load Regulation	VREG33_L	-	10	50	mV	IREF=0 to 6mA	
[Under Voltage Lock Out]							
VREG5 Threshold Voltage	VREG_UVLO	2.6	2.8	3.0	V	VREG:Sweep down	
VREG5 Hysteresis Voltage	DVREG_UVLO	50	100	200	mV	VREG:Sweep up	
[Oscillator Section]							
Oscillator Frequency	FOSC	270	300	330	kHz	RT=100 kΩ	
Synchronous Frequency	Fsync	-	550	-	kHz	RT=100 kΩ SYNC=550kHz	
Synchronous Pulse Low voltage	Vsynclow	GND	-	1.0	V		
Synchronous Pulse High voltage	Vsynchigh	3	-	VREG5	V		
SYNC input Current	Isync	10	20	30	μA	Vsync=5V	
[Error Amp]							
Open Loop Gain	Averr	-	46	-	dB		
VO Bias Current	Ivo+	-	-	1	μA		
Comp Source Current	Isource	-14	-7	-3	mA	VFB=0.6V	
Comp Sink Current	Isink	1	2	4	mA	VFB=1.0V	
Reference Voltage	VOB	0.792	0.800	0.808	V		
Temperature Coefficient of Reference Voltage	VOB+	-	±0.04	-	mV/°C		
Output rise Threshold	VODET	0.51	0.61	0.71	V	VFB	
Output Short Threshold	Vosh	0.46	0.56	0.66	V	VFB	
[Soft Start]							
Charging Current	ISS	6.5	10	13.5	μA	VSS=1V	
Temperature Coefficient of Charging Current	ISS+	-	±0.03	-	μA/°C	Vss=1V	
Discharging Current	IDIS	0.6	1.7	3	mA	VSS=1V,VCC=3V	
Temperature Coefficient of Discharging Current	IDIS+	-	±0.006	-	mA/°C	Vss=1V,VCC=3V	
Maximum Voltage	VSS_MAX	2.05	2.25	2.45	V		
Stand-by Voltage	VSS_STB	-	-	0.3	V	VCC=3V	
[FET Driver]							
HG Pch ON Resistance	HGhon	-	1.5	3.0	Ω		
HG Nch ON Resistance	HGlon	-	1.0	2.0	Ω		
LG Pch ON Resistance	LGhon	-	1.5	3.0	Ω		
LG Nch ON Resistance	LGlon	-	0.5	1.0	Ω		
[Over Current Protect.]							
CL Threshold voltage	Vswth	70	90	110	mV		
Temperature Coefficient of CL Threshold Voltage	Vswth+	-	±0.04	-	mV/°C		
CL Bias current 1	Iswin1	-	-	10	μA		
CL Bias current 2	Iswin2	-	-	10	μA		
[CTL]							
EN1,2 Low Voltage	VENTh1	GND	-	1.0	V		
EN1,2 High Voltage	VENTh2	2.0	-	Vcc	V		
EN1,2 input Current	IEN	10	20	30	μA	VEN=5V	

※Ensured by design

OBLOCK DIAGRAM

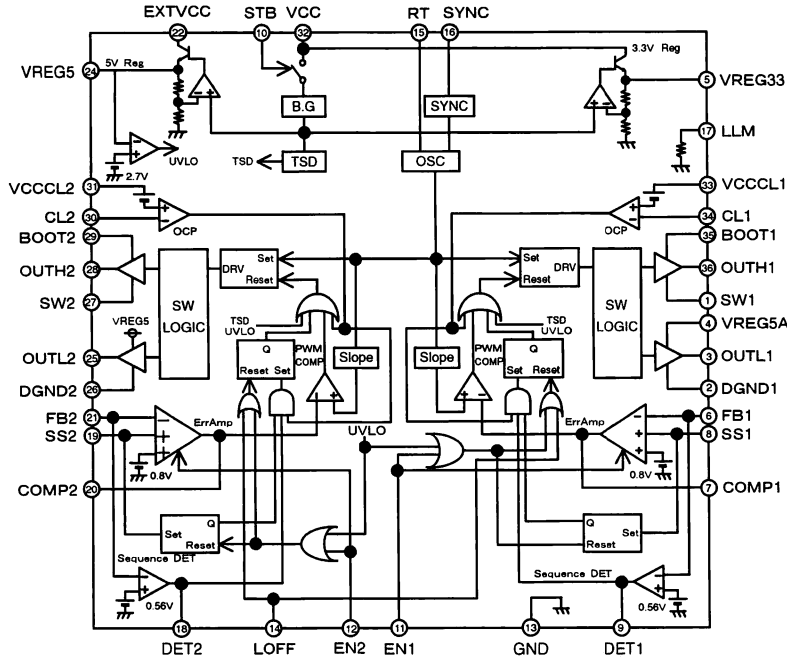

OPHYSICAL DIMENSIONS-MARKING

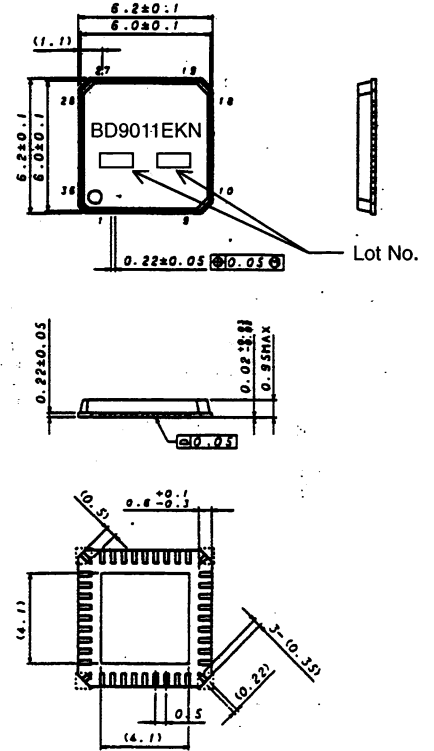

※Refer to the Technical Note about the details of the application.

○Pin No. • Pin Name

HQFN(Unit:mm)

Pin No.	Pin Name	Function	Pin No.	Pin Name	Function
1	SW1	High Side FET Source 1	19	SS2	Soft Start 2
2	DGND1	Low Side FET Source 1	20	COMP2	Error Amp Output 2
3	OUTL1	Low Side FET Gate Drive 1	21	FB2	Error Amp Inverting Input 2
4	VREG5A	FET Driver REG Input	22	EXTVCC	External Power Input
5	VREG33	3.3V Regulator Output	23	N.C	Non Connect
6	FB1	Error Amp Inverting Input 1	24	VREG5	5V Regulator Output
7	COMP1	Error Amp Output 1	25	OUTL2	Low Side FET Gate Driver 2
8	SS1	Soft Start 1	26	DGND2	Low Side FET Source 2
9	DET1	FB1 Detector Output 1	27	SW2	High Side FET Source 2
10	STB	Stand-by Input	28	OUTH2	High Aide FET Gate Driver 2
11	EN1	Control Voltage Input 1	29	BOOT2	OUTH2 Driver Supply Input
12	EN2	Control Voltage Input 2	30	CL2	OCP Setting terminal by External Resistance 2
13	GND	Ground	31	VCCCL2	Supply Voltage for OCP 2
14	LOFF	OCP OFF Latch ON/OFF CONTROL	32	VCC	Power Input
15	RT	Connect to External Resistor Setting Operating Frequency	33	VCCCL1	Supply Voltage for OCP 1
16	SYNC	Synchronized Pulse Input	34	CL1	OCP Setting terminal by External Resistance 2
17	LLM	Pull Down Resistance	35	BOOT1	OUTH1 Driver Supply Input
18	DET2	FB2 Detector Output 2	36	OUTH1	High Side FET Gate Driver 1

## NOTES FOR USE

1. **Absolute maximum range**  
Absolute Maximum Ratings are those values beyond which the life of a device may be destroyed we cannot be defined the failure mode, such as short mode or open mode.  
Therefore physical security countermeasure, like fuse, is to be given when a specific mode to be beyond absolute maximum ratings is considered.
2. **GND pin voltage**  
GND terminal should be connected the lowest voltage, under all conditions. And all terminals except SW should be under GND terminal voltage under all conditions including transient situations. If a terminal exists under GND, it should be inserting a bypass route.
3. **Power dissipation**  
If IC is used on condition that the power loss is over the power dissipation, the reliability will become worse by heat up, such as reduced output current capability.  
Also, be sure to use this IC within a power dissipation range allowing enough of margin.
4. **Input supply voltage**  
Input supply pattern layout should be as short as possible.
5. **Electrical characteristics described in these specifications may vary, depending on temperature, supply voltage, external circuits and other conditions. Therefore, be sure to check all relevant factors, including transient characteristics.**
6. **Thermal Shut Down Circuit**  
A temperature control is built in the IC to prevent the damage due to overheat. Therefore, the output is turned off without VREG5 when the thermal circuit works and are turned on when the temperature goes down to the specified level.
7. **Mounting Failures**  
Mounting failure, such as misdirection or mismount, may cause a malfunction in the device.
8. **Internal circuits or elements may be damaged when Vcc and pin voltage are reversed. For example, Vcc short circuit to GND while a external capacitor is charged. Pin capacitor of Vreg5 and VREG33 outputs is recommended no larger than 100  $\mu$  F. In addition, inserting a Vcc series countercurrent prevention diode, or a bypass diode between the various pins and the vcc, is recommended.**
9. **Malfunction may be happened when the device is used in the strong electromagnetic field.**
10. **We recommend to put Diode for protection purpose in case of output pin connected with large load of impedance or reserve current occurred at initial and output off.**
11. **Precautions for board inspection**  
Connecting low-impedance capacitors to run inspections with the board may produce stress on the IC. Therefore, be certain to use proper discharge procedure before each process of the test operation.  
To prevent electrostatic accumulation and discharge in the assembly process, thoroughly ground yourself and any equipment that could sustain ESD damage, and continue observing ESD-prevention procedures in all handling, transfer and storage operations. Before attempting to connect components to the test setup, make certain that the power supply is OFF. Likewise, be sure the power supply is OFF before removing any component connected to the test setup.
12. **GND pattern**  
When both a small-signal GND and high current GND are present, single-point grounding (at the set standard point ) is recommended, in order to separate the small-signal and high current patterns, and to be sure the voltage change stemming from the wiring resistance and high current does not cause any voltage change in the small-signal GND. In the same way, care must be taken to avoid voltage fluctuations in any connected external component GND.
13. **SW Terminal**  
A counter-electromotive force may generate a negative potential at the SW terminal during connection to the particular application. Therefore, it should be inserting a bypass route between SW to GND.
14. **Drop-out operation**  
A decrease in the input voltage to less than 90% of the output voltage (varies depending on operating frequency fluctuation) may prevent the MOS at the OUTL side to turn ON, which will, in turn, prevent BOOST STRAP operation. A load should be connected in order to reduce the SW voltage to the GND level in the event the difference in the input and output voltages is small.

### Notes

- No technical content pages of this document may be reproduced in any form or transmitted by any means without prior permission of ROHM CO.,LTD.
- The contents described herein are subject to change without notice. The specifications for the product described in this document are for reference only. Upon actual use, therefore, please request that specifications to be separately delivered.
- Application circuit diagrams and circuit constants contained herein are shown as examples of standard use and operation. Please pay careful attention to the peripheral conditions when designing circuits and deciding upon circuit constants in the set.
- Any data, including, but not limited to application circuit diagrams information, described herein are intended only as illustrations of such devices and not as the specifications for such devices. ROHM CO.,LTD. disclaims any warranty that any use of such devices shall be free from infringement of any third party's intellectual property rights or other proprietary rights, and further, assumes no liability of whatsoever nature in the event of any such infringement, or arising from or connected with or related to the use of such devices.
- Upon the sale of any such devices, other than for buyer's right to use such devices itself, resell or otherwise dispose of the same, no express or implied right or license to practice or commercially exploit any intellectual property rights or other proprietary rights owned or controlled by
- ROHM CO., LTD. is granted to any such buyer.
- Products listed in this document are no antiradiation design.

The products listed in this document are designed to be used with ordinary electronic equipment or devices (such as audio visual equipment, office-automation equipment, communications devices, electrical appliances and electronic toys).

Should you intend to use these products with equipment or devices which require an extremely high level of reliability and the malfunction of which would directly endanger human life (such as medical instruments, transportation equipment, aerospace machinery, nuclear-reactor controllers, fuel controllers and other safety devices), please be sure to consult with our sales representative in advance.

#### About Export Control Order in Japan

Products described herein are the objects of controlled goods in Annex 1 (Item 16) of Export Trade Control Order in Japan.

In case of export from Japan, please confirm if it applies to "objective" criteria or an "informed" (by MITI clause) on the basis of "catch all controls for Non-Proliferation of Weapons of Mass Destruction.

Thank you for your accessing to ROHM product informations.  
More detail product informations and catalogs are available,  
please contact your nearest sales office.

Please contact our sales offices for details ;

U.S.A / San Diego	TEL : +1(858)625-3630	FAX : +1(858)625-3670
Atlanta	TEL : +1(770)754-5972	FAX : +1(770)754-0691
Dallas	TEL : +1(972)312-8818	FAX : +1(972)312-0330
Germany / Dusseldorf	TEL : +49(2154)9210	FAX : +49(2154)921400
United Kingdom / London	TEL : +44(1)908-282-666	FAX : +44(1)908-282-528
France / Paris	TEL : +33(0)1 56 97 30 60	FAX : +33(0) 1 56 97 30 80
China / Hong Kong	TEL : +852(2)740-6262	FAX : +852(2)375-8971
Shanghai	TEL : +86(21)6279-2727	FAX : +86(21)6247-2066
Dilian	TEL : +86(411)8230-8549	FAX : +86(411)8230-8537
Beijing	TEL : +86(10)8525-2483	FAX : +86(10)8525-2489
Taiwan / Taipei	TEL : +866(2)2500-6956	FAX : +866(2)2503-2869
Korea / Seoul	TEL : +82(2)8182-700	FAX : +82(2)8182-715
Singapore	TEL : +65-6332-2322	FAX : +65-6332-5662
Malaysia / Kuala Lumpur	TEL : +60(3)7958-8355	FAX : +60(3)7958-8377
Philippines / Manila	TEL : +63(2)807-6872	FAX : +63(2)809-1422
Thailand / Bangkok	TEL : +66(2)254-4890	FAX : +66(2)256-6334

Japan /  
(Internal Sales)

Tokyo	2-1-1, Yaesu, Chuo-ku, Tokyo 104-0082	TEL : +81(3)5203-0321	FAX : +81(3)5203-0300
Yokohama	2-4-8, Shin Yokohama, Kohoku-ku, Yokohama, Kanagawa 222-8575	TEL : +81(45)476-2131	FAX : +81(45)476-2128
Nagoya	Dainagayo Building 9F 3-28-12, Meieki, Nakamura-ku, Nagoya, Aichi 450-0002	TEL : +81(52)581-8521	FAX : +81(52)561-2173
Kyoto	579-32 Higashi Shiokouji-cho, Karasuma Nishi-iru, Shiokoujidori, Shimogyo-ku, Kyoto 600-8216	TEL : +81(75)311-2121	FAX : +81(75)314-6559

(Contact address for overseas customers in Japan)

Yokohama	TEL : +81(45)476-9270	FAX : +81(045)476-9271
----------	-----------------------	------------------------