

DM7131/DM8131 6-Bit Unified Bus Comparator

General Description

The DM7131/DM8131 compares two binary words of two-to-six bits in length and indicates matching (bit-for-bit) of the two words. Inputs for one word are 54/74 series-compatible TTL inputs, whereas those of the second word are high-impedance receivers driven by a terminated data bus. These bus inputs include 0.65V typical hysteresis, which provides 1.4V noise immunity. The DM7131/DM8131 has active pull-up outputs and goes to the low state upon equality. The device has an output latch which is strobe controlled.

The transfer of information to the output occurs when the STROBE input goes from a logic "1" to a logic "0" state. Inputs may be changed while the STROBE is at the logic "1" level, without affecting the state of the output. These devices are useful as address comparators in computer systems utilizing unified data bus organization.

Features

- Low bus input current 15 μ A typ
- High bus input noise immunity 1.4V typ
- Bus inputs comply with IEEE 488-1975
- TTL-compatible output
- Output latch provision

Connection Diagram

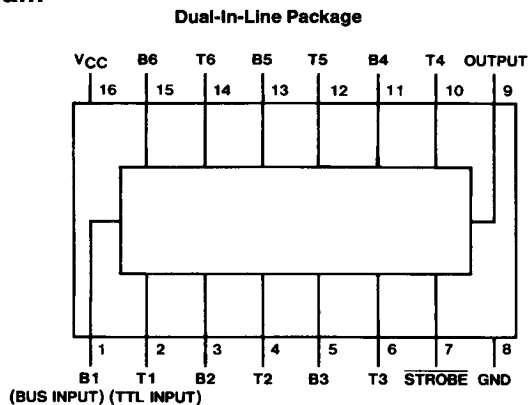

TL/F/6576-1

Order Number DM7131J or DM8131N
See NS Package Number J16A or N16A

Function Table

Condition	STROBE	Output
		DM71/8131
T = B, T \neq B	H	$Q_N - 1^*$
T = B	L	L
T \neq B	L	H

*Latched in a previous state.
H = High Logic Level.
L = Low Logic Level.

Absolute Maximum Ratings (Note)

Specifications for Military/Aerospace products are not contained in this datasheet. Refer to the associated reliability electrical test specifications document.

Supply Voltage	7V
Input Voltage	5.5V
Operating Free Air Temperature Range	
DM71	-55°C to +125°C
DM81	0°C to +70°C
Storage Temperature Range	-65°C to +150°C

Note: The "Absolute Maximum Ratings" are those values beyond which the safety of the device cannot be guaranteed. The device should not be operated at these limits. The parametric values defined in the "Electrical Characteristics" table are not guaranteed at the absolute maximum ratings. The "Recommended Operating Conditions" table will define the conditions for actual device operation.

Recommended Operating Conditions

Symbol	Parameter	DM7131			DM8131			Units
		Min	Nom	Max	Min	Nom	Max	
V _{CC}	Supply Voltage	4.5	5	5.5	4.75	5	5.25	V
V _{T+}	Positive-Going Input Threshold Voltage for Bus Inputs (Note 1)	1.4	1.75	2	1.45	1.75	1.95	V
V _{T-}	Negative-Going Input Threshold Voltage for Bus Inputs (Note 1)	0.9	1.1	1.35	0.95	1.1	1.3	V
V _{IH}	High Level Input Voltage for Strobe and TTL Inputs	2			2			V
V _{IL}	Low Level Input Voltage for Strobe and TTL Inputs			0.8			0.8	V
I _{OH}	High Level Output Current			-0.4			-0.4	mA
I _{OL}	Low Level Output Current			16			16	mA
T _A	Free Air Operating Temperature	-55		125	0		70	°C

Electrical Characteristics over recommended operating free air temperature range (unless otherwise noted)

Symbol	Parameter	Conditions	Min	Typ (Note 2)	Max	Units
V _I	Input Clamp Voltage	V _{CC} = Min, I _I = -12 mA			-1.5	V
V _{OH}	High Level Output Voltage	V _{CC} = Min, I _{OH} = Max V _{IL} = Max, V _{IH} = Min	2.4			V
V _{OL}	Low Level Output Voltage	V _{CC} = Min, I _{OL} = Max V _{IH} = Min, V _{IL} = Max			0.4	V
I _I	Input Current @ Max Input Voltage	V _{CC} = Max V _I = 5.5V	TTL		1	mA
			Strobe		2	
I _{IH}	High Level Input Current	V _{CC} = Max V _I = 2.4V	TTL		40	μA
			Strobe		80	
I _{IL}	Low Level Input Current	V _{CC} = Max V _I = 0.4V	TTL		-1.6	mA
			Strobe		-2.4	
I _{IN}	Bus Input Current	V _I = 4V	V _{CC} = Max	15	50	μA
			V _{CC} = 0V	1	50	
I _{OS}	Short Circuit Output Current	V _{CC} = Max (Note 3)	DM71	-18	-55	mA
			DM81	-18	-55	
I _{CC}	Supply Current	V _{CC} = Max (Note 4)		50	74	mA

Note 1: V_{CC} = 5V

Note 2: All typicals are at V_{CC} = 5V, T_A = 25°C.

Note 3: Not more than one output should be shorted at a time.

Note 4: I_{CC} is measured with all inputs grounded and all outputs open.

Switching Characteristics at $V_{CC} = 5V$ and $T_A = 25^\circ C$ (See Section 1 for Test Waveforms and Output Load)

Symbol	Parameter	From (Input) To (Output)	$R_L = 400\Omega, C_L = 15\text{ pF}$		Units
			Min	Max	
t_{PLH}	Propagation Delay Time Low to High Level Output	TTL to Output		30	ns
t_{PHL}	Propagation Delay Time High to Low Level Output	TTL to Output		30	ns
t_{PLH}	Propagation Delay Time Low to High Level Output	Bus to Output		45	ns
t_{PHL}	Propagation Delay Time High to Low Level Output	Bus to Output		45	ns
t_{PLH}	Propagation Delay Time Low to High Level Output	Strobe to Output		30	ns
t_{PHL}	Propagation Delay Time High to Low Level Output	Strobe to Output		30	ns

Logic Diagram

DM71/8131

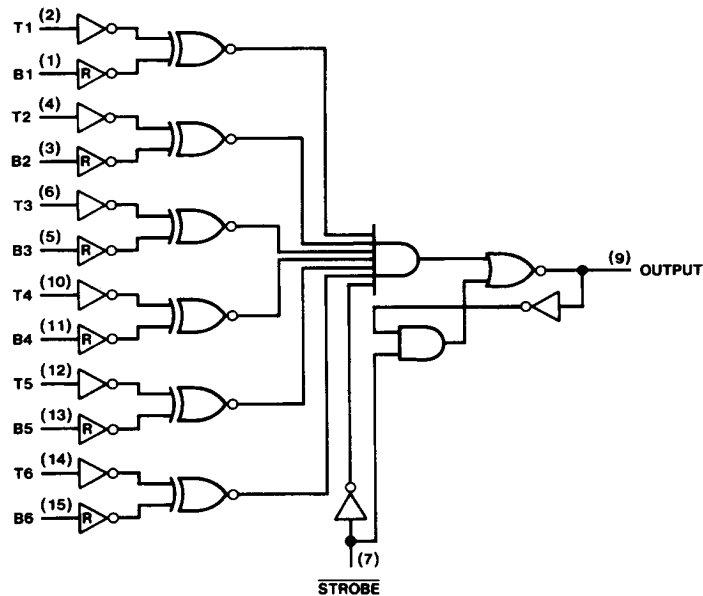

R = High Impedance
Bus Receiver

TL/F/6576-2