HB52R168DB-F

128 MB Unbuffered SDRAM S.O.DIMM
16-Mword \times 64-bit, 66 MHz Memory Bus, 1-Bank Module
(16 pcs of 16 M \times 4 components)

HITACHI

ADE-203-1098A (Z)

Rev. 1.0

Jan. 24, 2000

Description

The HB52R168DB is a 16M \times 64 \times 1 bank Synchronous Dynamic RAM Small Outline Dual In-line Memory Module (S.O.DIMM), mounted 16 pieces of 64-Mbit SDRAM (HM5264405FTB) sealed in TCP package and 1 piece of serial EEPROM (2-kbit) for Presence Detect (PD). An outline of the HB52R168DB is 144-pin Zig Zag Dual tabs socket type compact and thin package. Therefore, the HB52R168DB makes high density mounting possible without surface mount technology. The HB52R168DB provides common data inputs and outputs. Decoupling capacitors are mounted beside TCP on the module board.

Note: Do not push the cover or drop the modules in order to protect from mechanical defects, which would be electrical defects.

Features

- Fully compatible with JEDEC standard outline 8-byte S.O.DIMM
- 144-pin Zig Zag Dual tabs socket type
 - Outline: 67.60 mm (Length) \times 25.40 mm (Height) \times 3.80 mm (Thickness)
 - Lead pitch: 0.80 mm
- 3.3 V power supply
- Clock frequency: 66 MHz
- LVTTTL interface
- Data bus width: \times 64 Non parity
- Single pulsed $\overline{\text{RAS}}$
- 4 Banks can operates simultaneously and independently
- Burst read/write operation and burst read/single write operation capability
- Programmable burst length : 1/2/4/8/full page

HB52R168DB-F

- 2 variations of burst sequence
 - Sequential (BL = 1/2/4/8/full page)
 - Interleave (BL = 1/2/4/8)
- Programmable \overline{CE} latency: 2/3
- Byte control by DQMB
- Refresh cycles: 4096 refresh cycles/64 ms
- 2 variations of refresh
 - Auto refresh
 - Self refresh
- Low self refresh current: HB52R168DB-10FL (L-version)
- Full page burst length capability
 - Sequential burst
 - Burst stop capability

Ordering Information

Type No.	Frequency	\overline{CE} latency	Package	Contact pad
HB52R168DB-10F	66 MHz	2/3	Small outline DIMM (144-pin)	Gold
HB52R168DB-10FL	66 MHz	2/3		

Pin Arrangement

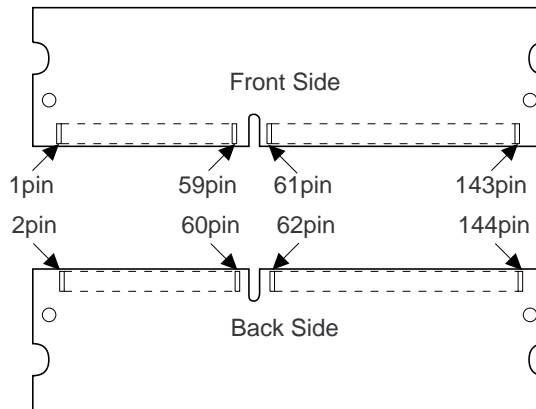

Pin Arrangement (cont.)

Front side				Back side			
Pin No.	Signal name	Pin No.	Signal name	Pin No.	Signal name	Pin No.	Signal name
1	V _{SS}	73	NC	2	V _{SS}	74	CK1
3	DQ0	75	V _{SS}	4	DQ32	76	V _{SS}
5	DQ1	77	NC	6	DQ33	78	NC
7	DQ2	79	NC	8	DQ34	80	NC
9	DQ3	81	V _{CC}	10	DQ35	82	V _{CC}
11	V _{CC}	83	DQ16	12	V _{CC}	84	DQ48
13	DQ4	85	DQ17	14	DQ36	86	DQ49
15	DQ5	87	DQ18	16	DQ37	88	DQ50
17	DQ6	89	DQ19	18	DQ38	90	DQ51
19	DQ7	91	V _{SS}	20	DQ39	92	V _{SS}
21	V _{SS}	93	DQ20	22	V _{SS}	94	DQ52
23	DQMB0	95	DQ21	24	DQMB4	96	DQ53
25	DQMB1	97	DQ22	26	DQMB5	98	DQ54
27	V _{CC}	99	DQ23	28	V _{CC}	100	DQ55
29	A0	101	V _{CC}	30	A3	102	V _{CC}
31	A1	103	A6	32	A4	104	A7
33	A2	105	A8	34	A5	106	A13 (BA0)
35	V _{SS}	107	V _{SS}	36	V _{SS}	108	V _{SS}
37	DQ8	109	A9	38	DQ40	110	A12 (BA1)
39	DQ9	111	A10 (AP)	40	DQ41	112	A11
41	DQ10	113	V _{CC}	42	DQ42	114	V _{CC}
43	DQ11	115	DQMB2	44	DQ43	116	DQMB6
45	V _{CC}	117	DQMB3	46	V _{CC}	118	DQMB7
47	DQ12	119	V _{SS}	48	DQ44	120	V _{SS}
49	DQ13	121	DQ24	50	DQ45	122	DQ56
51	DQ14	123	DQ25	52	DQ46	124	DQ57
53	DQ15	125	DQ26	54	DQ47	126	DQ58
55	V _{SS}	127	DQ27	56	V _{SS}	128	DQ59
57	NC	129	V _{CC}	58	NC	130	V _{CC}
59	NC	131	DQ28	60	NC	132	DQ60
61	CK0	133	DQ29	62	CKE0	134	DQ61
63	V _{CC}	135	DQ30	64	V _{CC}	136	DQ62
65	\overline{RE}	137	DQ31	66	\overline{CE}	138	DQ63

HB52R168DB-F

Front side

Back side

Pin No.	Signal name	Pin No.	Signal name	Pin No.	Signal name	Pin No.	Signal name
67	\overline{W}	139	V_{SS}	68	NC	140	V_{SS}
69	$\overline{S0}$	141	SDA	70	NC	142	SCL
71	NC	143	V_{CC}	72	NC	144	V_{CC}

Pin Description

Pin name

Function

A0 to A11

Address input

- Row address A0 to A11
- Column address A0 to A9

A12/A13

Bank select address BA1, BA0

DQ0 to DQ63

Data-input/output

$\overline{S0}$

Chip select

\overline{RE}

Row address asserted bank enable

\overline{CE}

Column address asserted

\overline{W}

Write enable

DQMB0 to DQMB7

Byte input/output mask

CK0/CK1

Clock input

CKE0

Clock enable

SDA

Data-input/output for serial PD

SCL

Clock input for serial PD

V_{CC}

Power supply

V_{SS}

Ground

NC

No connection

Serial PD Matrix*¹

Byte No.	Function described	Bit7	Bit6	Bit5	Bit4	Bit3	Bit2	Bit1	Bit0	Hex value	Comments
0	Number of bytes used by module manufacturer	1	0	0	0	0	0	0	0	80	128
1	Total SPD memory size	0	0	0	0	1	0	0	0	08	256 byte
2	Memory type	0	0	0	0	0	1	0	0	04	SDRAM
3	Number of row addresses bits	0	0	0	0	1	1	0	0	0C	12
4	Number of column addresses bits	0	0	0	0	1	0	1	0	0A	10
5	Number of banks	0	0	0	0	0	0	0	1	01	1
6	Module data width	0	1	0	0	0	0	0	0	40	64
7	Module data width (continued)	0	0	0	0	0	0	0	0	00	0 (+)
8	Module interface signal levels	0	0	0	0	0	0	0	1	01	LVTTTL
9	SDRAM cycle time (highest CE latency) 15 ns	1	1	1	1	0	0	0	0	F0	CL = 3
10	SDRAM access from Clock (highest CE latency) 9 ns	1	0	0	1	0	0	0	0	90	
11	Module configuration type	0	0	0	0	0	0	0	0	00	Non parity
12	Refresh rate/type	1	0	0	0	0	0	0	0	80	Normal (15.625 μs) Self refresh
13	SDRAM width	0	0	0	0	0	1	0	0	04	16M × 4
14	Error checking SDRAM width	0	0	0	0	0	0	0	0	00	—
15	SDRAM device attributes: minimum clock delay for back-to-back random column addresses	0	0	0	0	0	0	0	1	01	1 CLK
16	SDRAM device attributes: Burst lengths supported	1	0	0	0	1	1	1	1	8F	1, 2, 4, 8, full page
17	SDRAM device attributes: number of banks on SDRAM device	0	0	0	0	0	1	0	0	04	4
18	SDRAM device attributes: CE latency	0	0	0	0	0	1	1	0	06	2, 3
19	SDRAM device attributes: S latency	0	0	0	0	0	0	0	1	01	0
20	SDRAM device attributes: W latency	0	0	0	0	0	0	0	1	01	0
21	SDRAM module attributes	0	0	0	0	0	0	0	0	00	Non buffer

HB52R168DB-F

Byte No.	Function described	Bit7	Bit6	Bit5	Bit4	Bit3	Bit2	Bit1	Bit0	Hex value	Comments
22	SDRAM device attributes: General	0	0	0	0	1	1	1	0	0E	$V_{CC} \pm 10\%$
23	SDRAM cycle time (2nd highest \overline{CE} latency) 15 ns	1	1	1	1	0	0	0	0	F0	CL = 2
24	SDRAM access from Clock (2nd highest \overline{CE} latency) 9 ns	1	0	0	1	0	0	0	0	90	
25	SDRAM cycle time (3rd highest \overline{CE} latency) Undefined	0	0	0	0	0	0	0	0	00	
26	SDRAM access from Clock (3rd highest \overline{CE} latency) Undefined	0	0	0	0	0	0	0	0	00	
27	Minimum row precharge time	0	0	0	1	1	1	1	0	1E	30 ns
28	Row active to row active min	0	0	0	1	0	1	0	0	14	20 ns
29	\overline{RE} to \overline{CE} delay min	0	0	0	1	1	1	1	0	1E	30 ns
30	Minimum \overline{RE} pulse width	0	0	1	1	1	1	0	0	3C	60 ns
31	Density of each bank on module	0	0	1	0	0	0	0	0	20	128M byte
32	Address and command signal input setup time	0	0	1	1	0	0	0	0	30	3 ns
33	Address and command signal input hold time	0	0	0	1	0	1	0	1	15	1.5 ns
34	Data signal input setup time	0	0	1	1	0	0	0	0	30	3 ns
35	Data signal input hold time	0	0	0	1	0	1	0	1	15	1.5 ns
36 to 61	Superset information	0	0	0	0	0	0	0	0	00	Future use
62	SPD data revision code	0	0	0	1	0	0	1	0	12	Rev. 1.2A
63	Checksum for bytes 0 to 62	0	1	0	1	1	0	1	0	5A	90
64	Manufacturer's JEDEC ID code	0	0	0	0	0	1	1	1	07	HITACHI
65 to 71	Manufacturer's JEDEC ID code	0	0	0	0	0	0	0	0	00	
72	Manufacturing location	×	×	×	×	×	×	×	×	×	*3 (ASCII- 8bit code)
73	Manufacturer's part number	0	1	0	0	1	0	0	0	48	H
74	Manufacturer's part number	0	1	0	0	0	0	1	0	42	B
75	Manufacturer's part number	0	0	1	1	0	1	0	1	35	5
76	Manufacturer's part number	0	0	1	1	0	0	1	0	32	2
77	Manufacturer's part number	0	1	0	1	0	0	1	0	52	R

Byte No.	Function described	Bit7	Bit6	Bit5	Bit4	Bit3	Bit2	Bit1	Bit0	Hex value	Comments
78	Manufacturer's part number	0	0	1	1	0	0	0	1	31	1
79	Manufacturer's part number	0	0	1	1	0	1	1	0	36	6
80	Manufacturer's part number	0	0	1	1	1	0	0	0	38	8
81	Manufacturer's part number	0	1	0	0	0	1	0	0	44	D
82	Manufacturer's part number	0	1	0	0	0	0	1	0	42	B
83	Manufacturer's part number	0	0	1	0	1	1	0	1	2D	—
84	Manufacturer's part number	0	0	1	1	0	0	0	1	31	1
85	Manufacturer's part number	0	0	1	1	0	0	0	0	30	0
86	Manufacturer's part number	0	1	0	0	0	1	1	0	46	F
87	Manufacturer's part number (L-version)	0	1	0	0	1	1	0	0	4C	L
	Manufacturer's part number	0	0	1	0	0	0	0	0	20	(Space)
88	Manufacturer's part number	0	0	1	0	0	0	0	0	20	(Space)
89	Manufacturer's part number	0	0	1	0	0	0	0	0	20	(Space)
90	Manufacturer's part number	0	0	1	0	0	0	0	0	20	(Space)
91	Revision code	0	0	1	1	0	0	0	0	30	Initial
92	Revision code	0	0	1	0	0	0	0	0	20	(Space)
93	Manufacturing date	×	×	×	×	×	×	×	×	×	Year code (BCD)*4
94	Manufacturing date	×	×	×	×	×	×	×	×	×	Week code (BCD)*4
95 to 98	Assembly serial number	*6									
99 to 125	Manufacturer specific data	—									*5
126	Intel specification frequency	0	1	1	0	0	1	1	0	66	66 MHz
127	Intel specification \overline{CE} # latency support	0	0	0	0	0	1	1	0	06	CL = 2, 3

- Notes:
1. All serial PD data are not protected. 0: Serial data, "driven Low", 1: Serial data, "driven High"
These SPD are based on Intel specification (Rev.1.2A).
 2. Regarding byte32 to 35, based on JEDEC Committee Ballot JC42.5-97-119.
 3. Byte72 is manufacturing location code. (ex: In case of Japan, byte72 is 4AH. 4AH shows "J" on ASCII code.)
 4. Regarding byte93 and 94, based on JEDEC Committee Ballot JC42.5-97-135. BCD is "Binary Coded Decimal".
 5. All bits of 99 through 125 are not defined ("1" or "0").
 6. Bytes 95 through 98 are assembly serial number.

Block Diagram

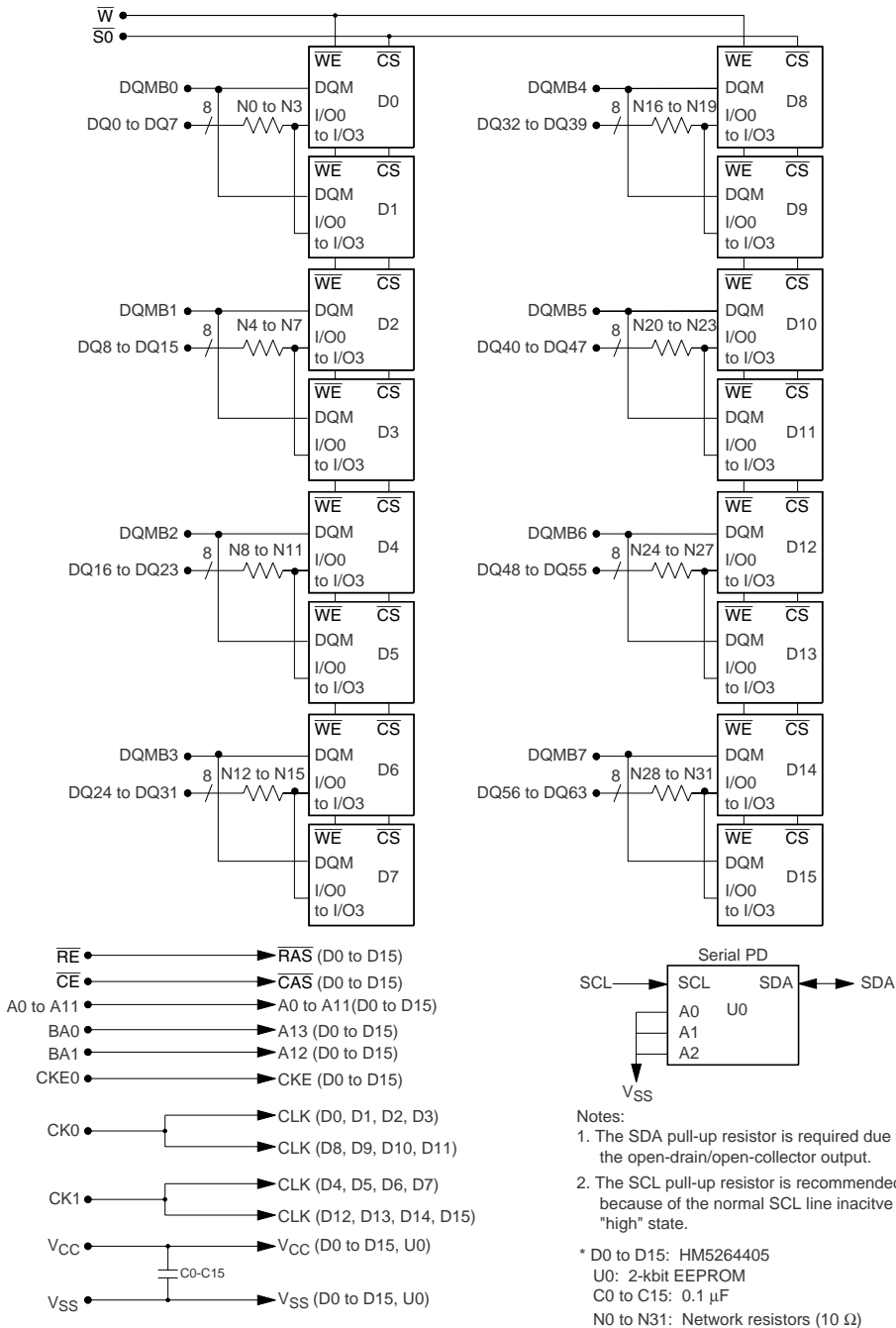

Absolute Maximum Ratings

Parameter	Symbol	Value	Unit	Note
Voltage on any pin relative to V_{SS}	V_T	-0.5 to $V_{CC} + 0.5$ (≤ 4.6 (max))	V	1
Supply voltage relative to V_{SS}	V_{CC}	-0.5 to +4.6	V	1
Short circuit output current	I_{out}	50	mA	
Power dissipation	P_T	16	W	
Operating temperature	T_{opr}	0 to +65	°C	
Storage temperature	T_{stg}	-55 to +125	°C	

Note: 1. Respect to V_{SS} .

DC Operating Conditions ($T_a = 0$ to +65°C)

Parameter	Symbol	Min	Typ	Max	Unit	Notes
Supply voltage	V_{CC}	3.0	3.3	3.6	V	1, 2
	V_{SS}	0	0	0	V	3
Input high voltage	V_{IH}	2.0	—	$V_{CC} + 0.3$	V	1, 4, 5
Input low voltage	V_{IL}	-0.3	—	0.8	V	1, 6
Ambient illuminance	—	—	—	100	lx	

Notes: 1. All voltage referred to V_{SS}

2. The supply voltage with all V_{CC} pins must be on the same level.
3. The supply voltage with all V_{SS} pins must be on the same level.
4. CK, CKE, \bar{S} , DQMB, DQ pins: V_{IH} (max) = $V_{CC} + 0.5$ V for pulse width ≤ 5 ns at V_{CC} .
5. Others: V_{IH} (max) = 4.6 V for pulse width ≤ 5 ns at V_{CC} .
6. V_{IL} (min) = -1.0 V for pulse width ≤ 5 ns at V_{SS} .

HB52R168DB-F

DC Characteristics (Ta = 0 to 65°C, V_{CC} = 3.3 V ± 0.3 V, V_{SS} = 0 V)

Parameter	Symbol	HB52R168DB		Unit	Test conditions	Notes
		Min	Max			
Operating current (\overline{CE} latency = 2)	I_{CC1}	—	960	mA	Burst length = 1 $t_{RC} = \min$	1, 2, 3
	I_{CC1}	—	960			
Standby current in power down	I_{CC2P}	—	24	mA	CKE0 = V _{IL} , $t_{CK} = 12$ ns	6
Standby current in power down (input signal stable)	I_{CC2PS}	—	16			
Standby current in non power down	I_{CC2N}	—	160	mA	CKE0, $\overline{S} = V_{IH}$, $t_{CK} = 12$ ns	4
Active standby current in power down	I_{CC3P}	—	64			
Active standby current in non power down	I_{CC3N}	—	288	mA	CKE0, $\overline{S} = V_{IH}$, $t_{CK} = 12$ ns	1, 2, 4
Burst operating current (\overline{CE} latency = 2)	I_{CC4}	—	880			
(\overline{CE} latency = 3)	I_{CC4}	—	880	mA	$t_{CK} = \min$, BL = 4	1, 2, 5
Refresh current	I_{CC5}	—	1760			
Self refresh current	I_{CC6}	—	16	mA	V _{IH} ≥ V _{CC} - 0.2 V V _{IL} ≤ 0.2 V	8
Self refresh current (L-version)	I_{CC6}	—	6.4			
Input leakage current	I_{LI}	-10	10	μA	0 ≤ Vin ≤ V _{CC}	
Output leakage current	I_{LO}	-10	10			
Output high voltage	V _{OH}	2.4	—	V	I _{OH} = -2 mA	
Output low voltage	V _{OL}	—	0.4			

- Notes: 1. I_{CC} depends on output load condition when the device is selected. I_{CC} (max) is specified at the output open condition.
2. One bank operation.
 3. Input signals are changed once per one clock.
 4. Input signals are changed once per two clocks.
 5. Input signals are changed once per four clocks.
 6. After power down mode, CK0/CK1 operating current.
 7. After power down mode, no CK0/CK1 operating current.
 8. After self refresh mode set, self refresh current.

Capacitance ($T_a = 25^\circ\text{C}$, $V_{CC} = 3.3\text{ V} \pm 0.3\text{ V}$)

Parameter	Symbol	Max	Unit	Notes
Input capacitance (Address)	C_{IN}	90	pF	1, 2, 4
Input capacitance (\overline{RE} , \overline{CE} , \overline{W} , \overline{S} , CKE)	C_{IN}	90	pF	1, 2, 4
Input capacitance (CK)	C_{IN}	60	pF	1, 2, 4
Input capacitance (DQMB)	C_{IN}	20	pF	1, 2, 4
Input/Output capacitance (DQ)	$C_{I/O}$	20	pF	1, 2, 3, 4

- Notes: 1. Capacitance measured with Boonton Meter or effective capacitance measuring method.
 2. Measurement condition: $f = 1\text{ MHz}$, 1.4 V bias, 200 mV swing.
 3. $DQMB = V_{IH}$ to disable Data-out.
 4. This parameter is sampled and not 100% tested.

AC Characteristics ($T_a = 0$ to 65°C , $V_{CC} = 3.3\text{ V} \pm 0.3\text{ V}$, $V_{SS} = 0\text{ V}$)

Parameter	Symbol	HB52R168DB		Unit	Notes
		Min	Max		
		-10F/10FL			
System clock cycle time (\overline{CE} latency = 2)	t_{CK}	15	—	ns	1
(\overline{CE} latency = 3)	t_{CK}	15	—		
CK0/CK1 high pulse width	t_{CKH}	5	—	ns	1
CK0/CK1 low pulse width	t_{CKL}	5	—	ns	1
Access time from CK0/CK1 (\overline{CE} latency = 2)	t_{AC}	—	9	ns	1, 2
(\overline{CE} latency = 3)	t_{AC}	—	9		
Data-out hold time	t_{OH}	2.5	—	ns	1, 2
CK0/CK1 to Data-out low impedance	t_{LZ}	2	—	ns	1, 2, 3
CK0/CK1 to Data-out high impedance	t_{HZ}	—	7	ns	1, 4
Data-in setup time	t_{DS}	3	—	ns	1
Data in hold time	t_{DH}	1.5	—	ns	1
Address setup time	t_{AS}	3	—	ns	1
Address hold time	t_{AH}	1.5	—	ns	1
CKE0 setup time	t_{CES}	3	—	ns	1, 5
CKE0 setup time for power down exit	t_{CESP}	3	—	ns	1
CKE0 hold time	t_{CEH}	1.5	—	ns	1

AC Characteristics (Ta = 0 to 65°C, V_{CC} = 3.3 V ± 0.3 V, V_{SS} = 0 V) (cont)

Parameter	Symbol	HB52R168DB		Unit	Notes
		Min	Max		
Command ($\overline{S0}$, \overline{RE} , \overline{CE} , \overline{W} , DQMB) setup time	t _{CS}	3	—	ns	1
Command ($\overline{S0}$, \overline{RE} , \overline{CE} , \overline{W} , DQMB) hold time	t _{CH}	1.5	—	ns	1
Ref/Active to Ref/Active command period	t _{RC}	105	—	ns	1
Active to precharge command period	t _{RAS}	60	120000	ns	1
Active command to column command (same bank)	t _{RCD}	30	—	ns	1
Precharge to active command period	t _{RP}	30	—	ns	1
Write recovery or data in to precharge lead time	t _{DPL}	30	—	ns	1
Active (a) to Active (b) command period	t _{RRD}	20	—	ns	1
Transition time (rise and fall)	t _T	1	5	ns	
Refresh period	t _{REF}	—	64	ms	

- Notes: 1. AC measurement assumes t_r = 1 ns. Reference level for timing of input signals is 1.4 V.
 2. Access time is measured at 1.4 V. Load condition is C_L = 50 pF with current source.
 3. t_{LZ} (min) defines the time at which the outputs achieves the low impedance state.
 4. t_{HZ} (max) defines the time at which the outputs achieves the high impedance state.
 5. t_{CES} defines CKE0 setup time to CK rising edge except power down exit command.

Test Conditions

- Input and output timing reference levels: 1.4 V
- Input waveform and output load: See following figures
- Ambient illuminance: Under 100 lx

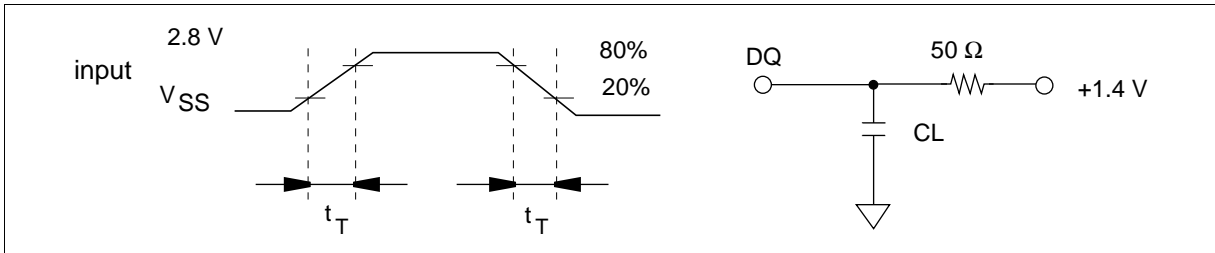

Relationship Between Frequency and Minimum Latency

Parameter	HB52R168DB		
	-10F/10FL		
Frequency (MHz)	66		
t_{CK} (ns)	Symbol	15	Notes
Active command to column command (same bank)	I_{RCD}	2	1
Active command to active command (same bank) (\overline{CE} latency = 2)	I_{RC}	7	= [$I_{RAS} + I_{RP}$] 1
(\overline{CE} latency = 3)	I_{RC}	8	
Active command to precharge command (same bank) (\overline{CE} latency = 2)	I_{RAS}	4	1
(\overline{CE} latency = 3)	I_{RAS}	5	
Precharge command to active command (same bank)	I_{RP}	3	1
Write recovery or data input to precharge command (same bank)	I_{DPL}	2	1
Active command to active command (different bank)	I_{RRD}	2	1
Self refresh exit time	I_{SREX}	2	2
Last data in to active command (Auto precharge, same bank)	I_{APW}	5	= [$I_{DPL} + I_{RP}$]
Self refresh exit to command input	I_{SEC}	7	= [I_{RC}] 3
Precharge command to high impedance (\overline{CE} latency = 2)	I_{HZP}	2	
(\overline{CE} latency = 3)	I_{HZP}	3	
Last data out to active command (auto precharge) (same bank)	I_{APR}	1	
Last data out to precharge (early precharge) (\overline{CE} latency = 2)	I_{EP}	-1	
(\overline{CE} latency = 3)	I_{EP}	-2	
Column command to column command	I_{CCD}	1	
Write command to data in latency	I_{WCD}	0	
DQMB to data in	I_{DID}	0	
DQMB to data out (\overline{CE} latency = 2)	I_{DOD}	2	
(\overline{CE} latency = 3)	I_{DOD}	3	
CKE0 to CK0/CK1 disable	I_{CLE}	1	

Relationship Between Frequency and Minimum Latency (cont)

Parameter	HB52R168DB		Notes
	-10F/10FL		
Frequency (MHz)		66	
t_{CK} (ns)	Symbol	15	
Register set to active command	t_{RSA}	3	
$\overline{S0}$ to command disable	I_{ODD}	0	
Power down exit to command input	I_{PEC}	1	
Burst stop to output valid data hold (\overline{CE} latency = 2)	I_{BSR}	1	
(\overline{CE} latency = 3)	I_{BSR}	2	
Burst stop to output high impedance (\overline{CE} latency = 2)	I_{BSH}	2	
(\overline{CE} latency = 3)	I_{BSH}	3	
Burst stop to write data ignore	I_{BSW}	0	

- Notes:
1. t_{RCD} to t_{RRD} are recommended value.
 2. Be valid [DSEL] or [NOP] at next command of self refresh exit.
 3. Except [DSEL] and [NOP]

Pin Functions

CK0/CK1 (input pin): CK is the master clock input to this pin. The other input signals are referred at CK rising edge.

$\overline{S0}$ (input pin): When \overline{S} is Low, the command input cycle becomes valid. When \overline{S} is High, all inputs are ignored. However, internal operations (bank active, burst operations, etc.) are held.

\overline{RE} , \overline{CE} and \overline{W} (input pins): Although these pin names are the same as those of conventional DRAM modules, they function in a different way. These pins define operation commands (read, write, etc.) depending on the combination of their voltage levels. For details, refer to the command operation section.

A0 to A11 (input pins): Row address (AX0 to AX11) is determined by A0 to A11 level at the bank active command cycle CK rising edge. Column address (AY0 to AY9) is determined by A0 to A9 level at the read or write command cycle CK rising edge. And this column address becomes burst access start address. A10 defines the precharge mode. When A10 = High at the precharge command cycle, both banks are precharged. But when A10 = Low at the precharge command cycle, only the bank that is selected by A12/A13 (BA) is precharged.

A12/A13 (input pin): A12/A13 is a bank select signal (BA). The memory array of the HB52R168DB is divided into bank0, bank1, bank2 and bank3, If A12 is Low and A13 is Low, bank0 is selected. If A12 is High and A13 is Low, bank1 is selected. If A12 is Low and A13 is High, bank2 is selected. If A12 is High and A13 is High, bank3 is selected.

CKE0 (input pin): This pin determines whether or not the next CK is valid. If CKE is High, the next CK rising edge is valid. If CKE is Low, the next CK rising edge is invalid. This pin is used for power-down and clock suspend modes.

DQMB0 to DQMB7 (input pins): Read operation: If DQMB is High, the output buffer becomes High-Z. If the DQMB is Low, the output buffer becomes Low-Z.

Write operation: If DQMB is High, the previous data is held (the new data is not written). If DQMB is Low, the data is written.

DQ0 to DQ63 (DQ pins): Data is input to and output from these pins.

V_{CC} (power supply pins): 3.3 V is applied.

V_{SS} (power supply pins): Ground is connected.

Command Operation

Command Truth Table

The SDRAM module recognizes the following commands specified by the \overline{S} , \overline{RE} , \overline{CE} , \overline{W} and address pins.

Command	Symbol	CKE						A12/ A13 A10		A0 to A11
		n - 1	n	\overline{S}	\overline{RE}	\overline{CE}	\overline{W}			
Ignore command	DESL	H	×	H	×	×	×	×	×	×
No operation	NOP	H	×	L	H	H	H	×	×	×
Burst stop in full page	BST	H	×	L	H	H	L	×	×	×
Column address and read command	READ	H	×	L	H	L	H	V	L	V
Read with auto-precharge	READ A	H	×	L	H	L	H	V	H	V
Column address and write command	WRIT	H	×	L	H	L	L	V	L	V
Write with auto-precharge	WRIT A	H	×	L	H	L	L	V	H	V
Row address strobe and bank act.	ACTV	H	×	L	L	H	H	V	V	V
Precharge select bank	PRE	H	×	L	L	H	L	V	L	×
Precharge all bank	PALL	H	×	L	L	H	L	×	H	×
Refresh	REF/SELF	H	V	L	L	L	H	×	×	×
Mode register set	MRS	H	×	L	L	L	L	V	V	V

Note: H: V_{IH} . L: V_{IL} . ×: V_{IH} or V_{IL} . V: Valid address input

Ignore command [DESL]: When this command is set (\overline{S} is High), the SDRAM module ignore command input at the clock. However, the internal status is held.

No operation [NOP]: This command is not an execution command. However, the internal operations continue.

Burst stop in full-page [BST]: This command stops a full-page burst operation (burst length = full-page), and is illegal otherwise. When data input/output is completed for a full page of data, it automatically returns to the start address, and input/output is performed repeatedly.

Column address strobe and read command [READ]: This command starts a read operation. In addition, the start address of burst read is determined by the column address and the bank select address (BA). After the read operation, the output buffer becomes High-Z.

Read with auto-precharge [READ A]: This command automatically performs a precharge operation after a burst read with a burst length of 1, 2, 4, or 8. When the burst length is full-page, this command is illegal.

Column address strobe and write command [WRIT]: This command starts a write operation. When the burst write mode is selected, the column address and the bank select address (BA) become the burst write start address. When the single write mode is selected, data is only written to the location specified by the column address and the bank select address (BA).

Write with auto-precharge [WRIT A]: This command automatically performs a precharge operation after a burst write with a length of 1, 2, 4, or 8, or after a single write operation. When the burst length is full-page, this command is illegal.

Row address strobe and bank activate [ACTV]: This command activates the bank that is selected by bank select address (BA) and determines the row address (AX0 to AX11). When A12 and A13 are Low, bank0 is activated. When A12 is High and A13 is Low, bank1 is activated. When A12 is Low and A13 is High, bank2 is activated. When A12 and A13 are High, bank3 is activated.

Precharge selected bank [PRE]: This command starts precharge operation for the bank selected by A12/A13. If A12 and A13 are Low, bank0 is selected. If A12 is High and A13 is Low, bank1 is selected. If A12 is Low and A13 is High, bank2 is selected. If A12 and A13 are High, bank3 is selected.

Precharge all banks [PALL]: This command starts a precharge operation for all banks.

Refresh [REF/SELF]: This command starts the refresh operation. There are two types of refresh operation, the one is auto-refresh, and the other is self-refresh. For details, refer to the CKE0 truth table section.

Mode register set [MRS]: The SDRAM module has a mode register that defines how it operates. The mode register is specified by the address pins (A0 to A13) at the mode register set cycle. For details, refer to the mode register configuration. After power on, the contents of the mode register are undefined, execute the mode register set command to set up the mode register.

DQMB Truth Table

Command	Symbol	CKE		DQMB
		n - 1	n	
Write enable/output enable	ENB	H	×	L
Write inhibit/output disable	MASK	H	×	H

Note: H: V_{IH} , L: V_{IL} , ×: V_{IH} or V_{IL} .

Read: I_{DOD} is needed.

Write: I_{DOD} is needed.

The SDRAM module can mask input/output data by means of DQMB. During reading, the output buffer is set to Low-Z by setting DQMB to Low, enabling data output. On the other hand, when DQMB is set to High, the output buffer becomes High-Z, disabling data output. During writing, data is written by setting DQMB to Low. When DQMB is set to High, the previous data is held (the new data is not written). Desired data can be masked during burst read or burst write by setting DQMB. For details, refer to the DQMB control section of the SDRAM module operating instructions.

CKE Truth Table

Current state	Command	CKE						Address
		n-1	n	\overline{S}	\overline{RE}	\overline{CE}	\overline{W}	
Active	Clock suspend mode entry	H	L	×	×	×	×	×
Any	Clock suspend	L	L	×	×	×	×	×
Clock suspend	Clock suspend mode exit	L	H	×	×	×	×	×
Idle	Auto refresh command REF	H	H	L	L	L	H	×
Idle	Self refresh entry SELF	H	L	L	L	L	H	×
Idle	Power down entry	H	L	L	H	H	H	×
		H	L	H	×	×	×	×
Self-refresh	Self refresh exit SELFX	L	H	L	H	H	H	×
		L	H	H	×	×	×	×
Power down	Power down exit	L	H	L	H	H	H	×
		L	H	H	×	×	×	×

Note: H: V_{IH} , L: V_{IL} , ×: V_{IH} or V_{IL} .

Clock suspend mode entry: The SDRAM module enters clock suspend mode from active mode by setting CKE to Low. If command is input in the clock suspend mode entry cycle, the command is valid. The clock suspend mode changes depending on the current status (1 clock before) as shown below.

ACTIVE clock suspend: This suspend mode ignores inputs after the next clock by internally maintaining the bank active status.

READ suspend and READ with Auto-precharge suspend: The data being output is held (and continues to be output).

WRITE suspend and WRIT with Auto-precharge suspend: In this mode, external signals are not accepted. However, the internal state is held.

Clock suspend: During clock suspend mode, keep the CKE to Low.

Clock suspend mode exit: The SDRAM module exits from clock suspend mode by setting CKE to High during the clock suspend state.

IDLE: In this state, all banks are not selected, and completed precharge operation.

Auto refresh command [REF]: When this command is input from the IDLE state, the SDRAM module starts auto refresh operation. (The auto refresh is the same as the CBR refresh of conventional DRAM module.) During the auto refresh operation, refresh address and bank select address are generated inside the SDRAM module. For every auto refresh cycle, the internal address counter is updated. Accordingly, 4096 times are required to refresh the entire memory. Before executing the auto refresh command, all the banks must be in the IDLE state. In addition, since the precharge for all banks is automatically performed after auto refresh, no precharge command is required after auto refresh.

Self refresh entry [SELF]: When this command is input during the IDLE state, the SDRAM module starts self refresh operation. After the execution of this command, self refresh continues while CKE0 is Low. Since self refresh is performed internally and automatically, external refresh operations are unnecessary.

Power down mode entry: When this command is executed during the IDLE state, the SDRAM module enters power down mode. In power down mode, power consumption is suppressed by cutting off the initial input circuit.

Self refresh exit: When this command is executed during self refresh mode, the SDRAM module can exit from self refresh mode. After exiting from self refresh mode, the SDRAM module enters the IDLE state.

Power down exit: When this command is executed at the power down mode, the SDRAM module can exit from power down mode. After exiting from power down mode, the SDRAM module enters the IDLE state.

Function Truth Table

The following table shows the operations that are performed when each command is issued in each mode of the SDRAM module. The following table assumes that CKE is high.

Current state	\bar{S}	\bar{RE}	\bar{CE}	\bar{W}	Address	Command	Operation
Precharge	H	×	×	×	×	DESL	Enter IDLE after t_{RP}
	L	H	H	H	×	NOP	Enter IDLE after t_{RP}
	L	H	H	L	×	BST	NOP
	L	H	L	H	BA, CA, A10	READ/READ A	ILLEGAL
	L	H	L	L	BA, CA, A10	WRIT/WRIT A	ILLEGAL
	L	L	H	H	BA, RA	ACTV	ILLEGAL
	L	L	H	L	BA, A10	PRE, PALL	NOP
	L	L	L	H	×	REF, SELF	ILLEGAL
	L	L	L	L	MODE	MRS	ILLEGAL
Idle	H	×	×	×	×	DESL	NOP
	L	H	H	H	×	NOP	NOP
	L	H	H	L	×	BST	NOP
	L	H	L	H	BA, CA, A10	READ/READ A	ILLEGAL
	L	H	L	L	BA, CA, A10	WRIT/WRIT A	ILLEGAL
	L	L	H	H	BA, RA	ACTV	Bank and row active
	L	L	H	L	BA, A10	PRE, PALL	NOP
	L	L	L	H	×	REF, SELF	Refresh
	L	L	L	L	MODE	MRS	Mode register set

HB52R168DB-F

Current state	\overline{S}	\overline{RE}	\overline{CE}	\overline{W}	Address	Command	Operation
Row active	H	x	x	x	x	DESL	NOP
	L	H	H	H	x	NOP	NOP
	L	H	H	L	x	BST	NOP
	L	H	L	H	BA, CA, A10	READ/READ A	Begin read
	L	H	L	L	BA, CA, A10	WRIT/WRIT A	Begin write
	L	L	H	H	BA, RA	ACTV	Other bank active ILLEGAL on same bank ^{*3}
	L	L	H	L	BA, A10	PRE, PALL	Precharge
	L	L	L	H	x	REF, SELF	ILLEGAL
	L	L	L	L	MODE	MRS	ILLEGAL
Read	H	x	x	x	x	DESL	Continue burst to end
	L	H	H	H	x	NOP	Continue burst to end
	L	H	H	L	x	BST	Burst stop to full page
	L	H	L	H	BA, CA, A10	READ/READ A	Continue burst read to \overline{CE} latency and new read
	L	H	L	L	BA, CA, A10	WRIT/WRIT A	Term burst read/start write
	L	L	H	H	BA, RA	ACTV	Other bank active ILLEGAL on same bank ^{*3}
	L	L	H	L	BA, A10	PRE, PALL	Term burst read and Precharge
	L	L	L	H	x	REF, SELF	ILLEGAL
	L	L	L	L	MODE	MRS	ILLEGAL
Read with auto-precharge	H	x	x	x	x	DESL	Continue burst to end and precharge
	L	H	H	H	x	NOP	Continue burst to end and precharge
	L	H	H	L	x	BST	ILLEGAL
	L	H	L	H	BA, CA, A10	READ/READ A	ILLEGAL
	L	H	L	L	BA, CA, A10	WRIT/WRIT A	ILLEGAL
	L	L	H	H	BA, RA	ACTV	Other bank active ILLEGAL on same bank ^{*3}
	L	L	H	L	BA, A10	PRE, PALL	ILLEGAL
	L	L	L	H	x	REF, SELF	ILLEGAL
	L	L	L	L	MODE	MRS	ILLEGAL

Current state	\overline{S}	\overline{RE}	\overline{CE}	\overline{W}	Address	Command	Operation
Write	H	x	x	x	x	DESL	Continue burst to end
	L	H	H	H	x	NOP	Continue burst to end
	L	H	H	L	x	BST	Burst stop on full page
	L	H	L	H	BA, CA, A10	READ/READ A	Term burst and new read
	L	H	L	L	BA, CA, A10	WRIT/WRIT A	Term burst and new write
	L	L	H	H	BA, RA	ACTV	Other bank active ILLEGAL on same bank* ³
	L	L	H	L	BA, A10	PRE, PALL	Term burst write and precharge* ²
	L	L	L	H	x	REF, SELF	ILLEGAL
	L	L	L	L	MODE	MRS	ILLEGAL
Write with auto-precharge	H	x	x	x	x	DESL	Continue burst to end and precharge
	L	H	H	H	x	NOP	Continue burst to end and precharge
	L	H	H	L	x	BST	ILLEGAL
	L	H	L	H	BA, CA, A10	READ/READ A	ILLEGAL
	L	H	L	L	BA, CA, A10	WRIT/WRIT A	ILLEGAL
	L	L	H	H	BA, RA	ACTV	Other bank active ILLEGAL on same bank* ³
	L	L	H	L	BA, A10	PRE, PALL	ILLEGAL
	L	L	L	H	x	REF, SELF	ILLEGAL
	L	L	L	L	MODE	MRS	ILLEGAL
Refresh (auto refresh)	H	x	x	x	x	DESL	Enter IDLE after t_{RC}
	L	H	H	H	x	NOP	Enter IDLE after t_{RC}
	L	H	H	L	x	BST	Enter IDLE after t_{RC}
	L	H	L	H	BA, CA, A10	READ/READ A	ILLEGAL
	L	H	L	L	BA, CA, A10	WRIT/WRIT A	ILLEGAL
	L	L	H	H	BA, RA	ACTV	ILLEGAL
	L	L	H	L	BA, A10	PRE, PALL	ILLEGAL
	L	L	L	H	x	REF, SELF	ILLEGAL
	L	L	L	L	MODE	MRS	ILLEGAL

Notes: 1. H: V_{IH} . L: V_{IL} . x: V_{IH} or V_{IL} .

The other combinations are inhibit.

2. An interval of t_{DPL} is required between the final valid data input and the precharge command.

3. If t_{RRD} is not satisfied, this operation is illegal.

From PRECHARGE state, command operation

To [DESL], [NOP] or [BST]: When these commands are executed, the SDRAM module enters the IDLE state after t_{RP} has elapsed from the completion of precharge.

From IDLE state, command operation

To [DESL], [NOP], [BST], [PRE] or [PALL]: These commands result in no operation.

To [ACTV]: The bank specified by the address pins and the ROW address is activated.

To [REF], [SELF]: The SDRAM module enters refresh mode (auto refresh or self refresh).

To [MRS]: The SDRAM module enters the mode register set cycle.

From ROW ACTIVE state, command operation

To [DESL], [NOP] or [BST]: These commands result in no operation.

To [READ], [READ A]: A read operation starts. (However, an interval of t_{RCD} is required.)

To [WRIT], [WRIT A]: A write operation starts. (However, an interval of t_{RCD} is required.)

To [ACTV]: This command makes the other bank active. (However, an interval of t_{RRD} is required.) Attempting to make the currently active bank active results in an illegal command.

To [PRE], [PALL]: These commands set the SDRAM module to precharge mode. (However, an interval of t_{RAS} is required.)

From READ state, command operation

To [DESL], [NOP]: These commands continue read operations until the burst operation is completed.

To [BST]: This command stops a full-page burst.

To [READ], [READ A]: Data output by the previous read command continues to be output. After \overline{CE} latency, the data output resulting from the next command will start.

To [WRIT], [WRIT A]: These commands stop a burst read, and start a write cycle.

To [ACTV]: This command makes other banks bank active. (However, an interval of t_{RRD} is required.) Attempting to make the currently active bank active results in an illegal command.

To [PRE], [PALL]: These commands stop a burst read, and the SDRAM module enters precharge mode.

From READ with AUTO PRECHARGE state, command operation

To [DESL], [NOP]: These commands continue read operations until the burst operation is completed, and the SDRAM module then enters precharge mode.

To [ACTV]: This command makes other banks bank active. (However, an interval of t_{RRD} is required.) Attempting to make the currently active bank active results in an illegal command.

From WRITE state, command operation

To [DESL], [NOP]: These commands continue write operations until the burst operation is completed.

To [BST]: This command stops a full-page burst.

To [READ], [READ A]: These commands stop a burst and start a read cycle.

To [WRIT], [WRIT A]: These commands stop a burst and start the next write cycle.

To [ACTV]: This command makes the other bank active. (However, an interval of t_{RRD} is required.) Attempting to make the currently active bank active results in an illegal command.

To [PRE], [PALL]: These commands stop burst write and the SDRAM module then enters precharge mode.

From WRITE with AUTO-PRECHARGE state, command operation

To [DESL], [NOP]: These commands continue write operations until the burst is completed, and the SDRAM module enters precharge mode.

To [ACTV]: This command makes the other bank active. (However, an interval of t_{RRD} is required.) Attempting to make the currently active bank active results in an illegal command.

From REFRESH state, command operation

To [DESL], [NOP], [BST]: After an auto-refresh cycle (after t_{RC}), the SDRAM module automatically enters the IDLE state.

Simplified State Diagram

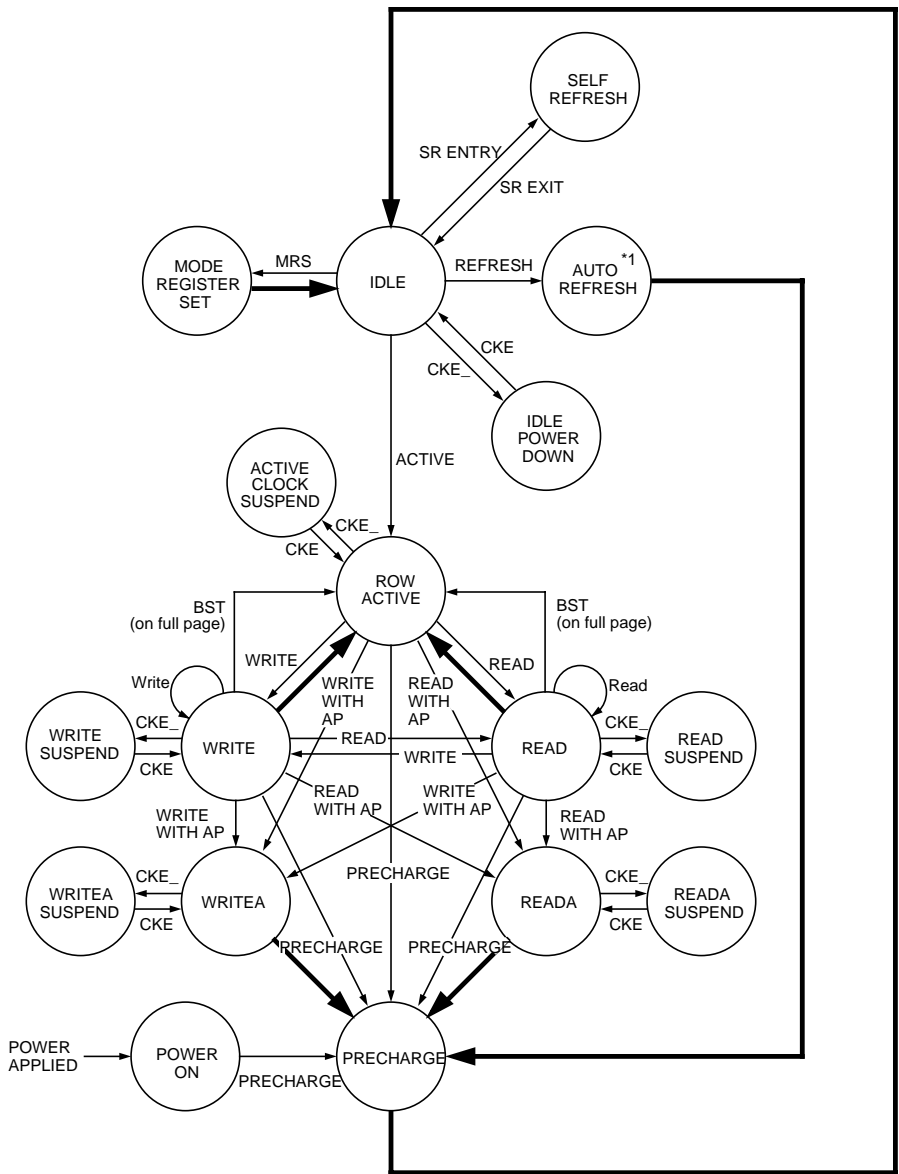

- ➔ Automatic transition after completion of command.
- Transition resulting from command input.

Note: 1. After the auto-refresh operation, precharge operation is performed automatically and enter the IDLE state.

Mode Register Configuration

The mode register is set by the input to the address pins (A0 to A13) during mode register set cycles. The mode register consists of five sections, each of which is assigned to address pins.

A13, A12, A11, A10, A9, A8: (OPCODE): The SDRAM module has two types of write modes. One is the burst write mode, and the other is the single write mode. These bits specify write mode.

Burst read and burst write: Burst write is performed for the specified burst length starting from the column address specified in the write cycle.

Burst read and single write: Data is only written to the column address specified during the write cycle, regardless of the burst length.

A7: Keep this bit Low at the mode register set cycle. If this pin is high, the vendor test mode is set.

A6, A5, A4: (LMODE): These pins specify the \overline{CE} latency.

A3: (BT): A burst type is specified. When full-page burst is performed, only “sequential” can be selected.

A2, A1, A0: (BL): These pins specify the burst length.

A13	A12	A11	A10	A9	A8	A7	A6	A5	A4	A3	A2	A1	A0
OPCODE						0	LMODE			BT	BL		

A6	A5	A4	CAS Latency
0	0	0	R
0	0	1	R
0	1	0	2
0	1	1	3
1	X	X	R

A3	Burst Type
0	Sequential
1	Interleave

A2	A1	A0	Burst Length	
			BT=0	BT=1
0	0	0	1	1
0	0	1	2	2
0	1	0	4	4
0	1	1	8	8
1	0	0	R	R
1	0	1	R	R
1	1	0	R	R
1	1	1	F.P.	R

A13	A12	A11	A10	A9	A8	Write mode
0	0	0	0	0	0	Burst read and burst write
X	X	X	X	0	1	R
X	X	X	X	1	0	Burst read and single write
X	X	X	X	1	1	R

F.P. = Full Page
 R is Reserved (inhibit)
 X: 0 or 1

Burst Sequence

Burst length = 2

Starting Ad.	Addressing(decimal)	
A0	Sequential	Interleave
0	0, 1,	0, 1,
1	1, 0,	1, 0,

Burst length = 4

Starting Ad.		Addressing(decimal)	
A1	A0	Sequential	Interleave
0	0	0, 1, 2, 3,	0, 1, 2, 3,
0	1	1, 2, 3, 0,	1, 0, 3, 2,
1	0	2, 3, 0, 1,	2, 3, 0, 1,
1	1	3, 0, 1, 2,	3, 2, 1, 0,

Burst length = 8

Starting Ad.			Addressing(decimal)	
A2	A1	A0	Sequential	Interleave
0	0	0	0, 1, 2, 3, 4, 5, 6, 7,	0, 1, 2, 3, 4, 5, 6, 7,
0	0	1	1, 2, 3, 4, 5, 6, 7, 0,	1, 0, 3, 2, 5, 4, 7, 6,
0	1	0	2, 3, 4, 5, 6, 7, 0, 1,	2, 3, 0, 1, 6, 7, 4, 5,
0	1	1	3, 4, 5, 6, 7, 0, 1, 2,	3, 2, 1, 0, 7, 6, 5, 4,
1	0	0	4, 5, 6, 7, 0, 1, 2, 3,	4, 5, 6, 7, 0, 1, 2, 3,
1	0	1	5, 6, 7, 0, 1, 2, 3, 4,	5, 4, 7, 6, 1, 0, 3, 2,
1	1	0	6, 7, 0, 1, 2, 3, 4, 5,	6, 7, 4, 5, 2, 3, 0, 1,
1	1	1	7, 0, 1, 2, 3, 4, 5, 6,	7, 6, 5, 4, 3, 2, 1, 0,

Operation of the SDRAM module

Read/Write Operations

Bank active: Before executing a read or write operation, the corresponding bank and the row address must be activated by the bank active (ACTV) command. Bank0, bank1, bank2 or bank3 is activated according to the status of the bank select address pin, and the row address (AX0 to AX11) is activated by the A0 to A11 pins at the bank active command cycle. An interval of t_{RCD} is required between the bank active command input and the following read/write command input.

Read operation: A read operation starts when a read command is input. Output buffer becomes Low-Z in the (\overline{CE} Latency-1) cycle after read command set. The SDRAM module can perform a burst read operation. The burst length can be set to 1, 2, 4, 8 or full-page. The start address for a burst read is specified by the column address and the bank select address (BA) at the read command set cycle. In a read operation, data output starts after the number of clocks specified by the \overline{CE} Latency. The \overline{CE} Latency can be set to 2 or 3. When the burst length is 1, 2, 4, or 8, full-page, the Dout buffer automatically becomes High-Z at the next clock after the successive burst-length data has been output. The \overline{CE} latency and burst length must be specified at the mode register.

\overline{CE} Latency

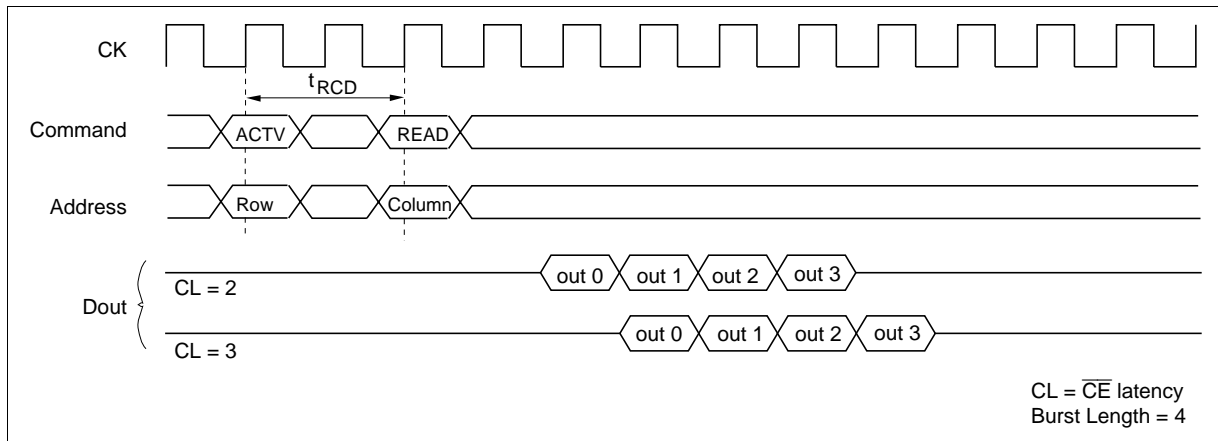

Burst Length

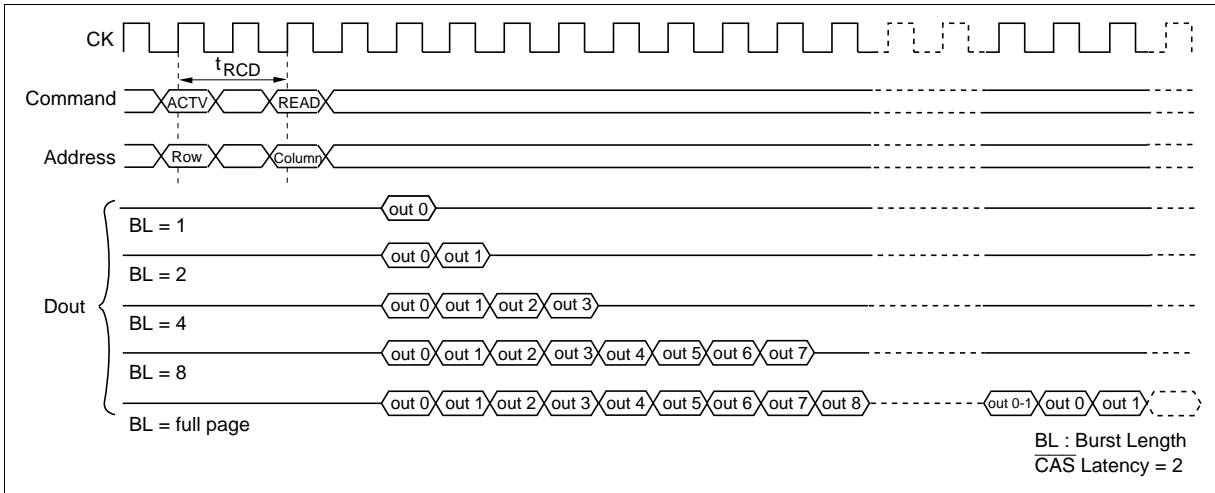

Write operation: Burst write or single write mode is selected by the OPCODE (A13, A12, A11, A10, A9, A8) of the mode register.

Burst write

A burst write operation is enabled by setting OPCODE (A9, A8) to (0, 0). A burst write starts in the same clock as a write command set. (The latency of data input is 0 clock.) The burst length can be set to 1, 2, 4, 8, and full-page, like burst read operations. The write start address is specified by the column address and the bank select address (BA) at the write command set cycle.

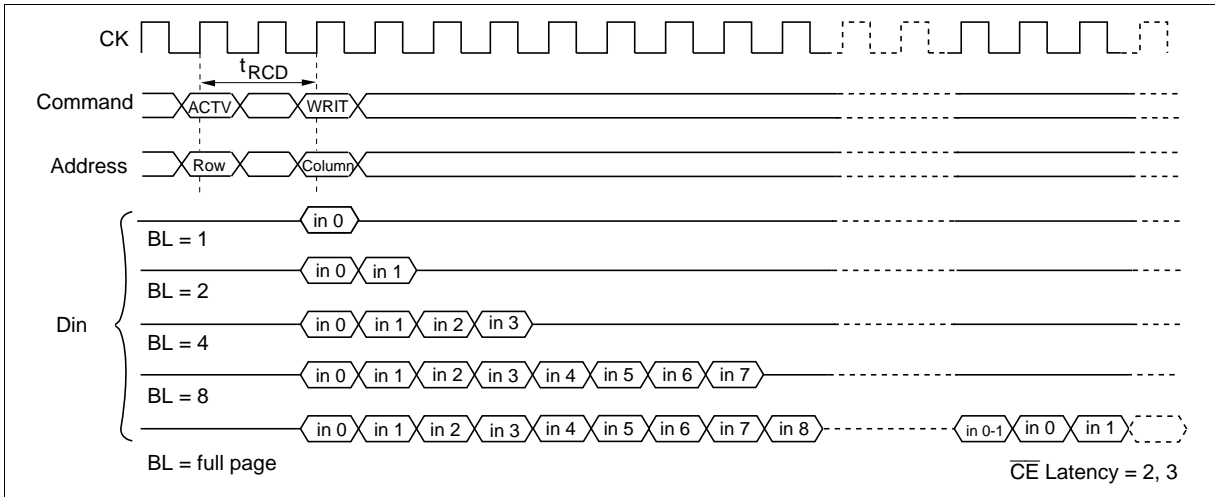

Single write

A single write operation is enabled by setting OPCODE (A9, A8) to (1, 0). In a single write operation, data is only written to the column address and the bank select address (BA) specified by the write command set cycle without regard to the burst length setting. (The latency of data input is 0 clock).

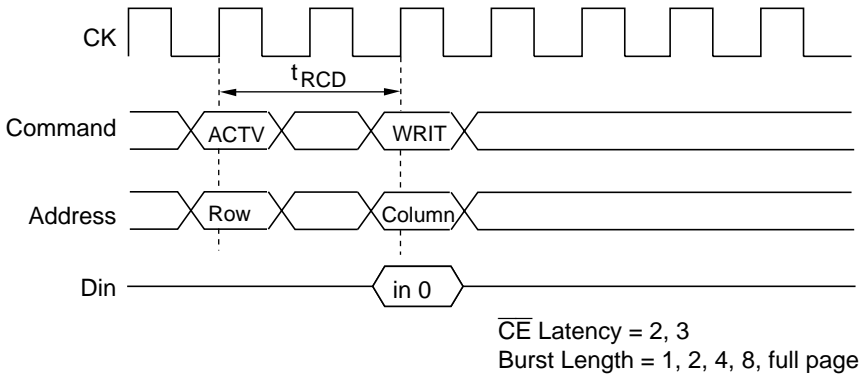

Auto Precharge

Read with auto precharge: In this operation, since precharge is automatically performed after completing a read operation, a precharge command need not be executed after each read operation. The command executed for the same bank after the execution of this command must be the bank active (ACTV) command. In addition, an interval defined by I_{APR} is required before execution of the next command.

CE latency

Precharge start cycle

3	2 cycle before the final data is output
2	1 cycle before the final data is output

Burst Read (Burst Length = 4)

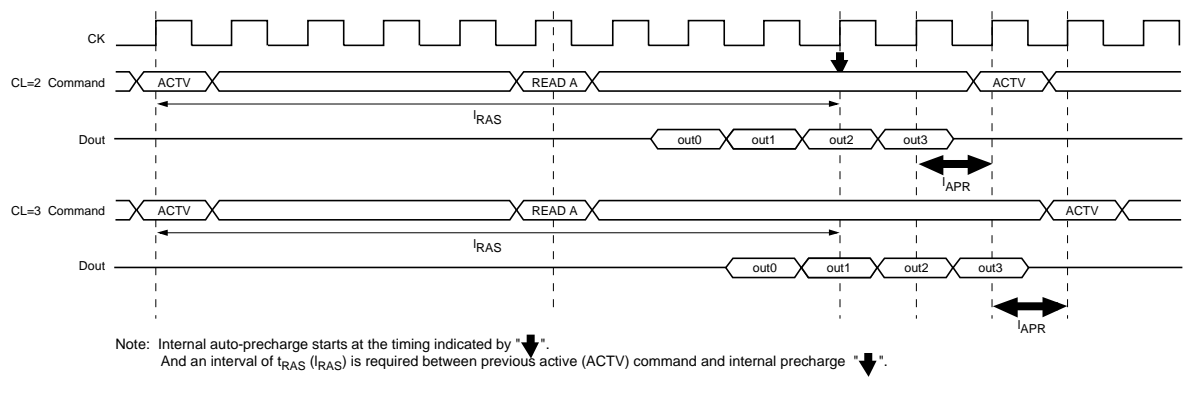

Write with auto-precharge: In this operation, since precharge is automatically performed after completing a burst write or single write operation, a precharge command need not be executed after each write operation. The command executed for the same bank after the execution of this command must be the bank active (ACTV) command. In addition, an interval of I_{APW} is required between the final valid data input and input of next command.

Burst Write (Burst Length = 4)

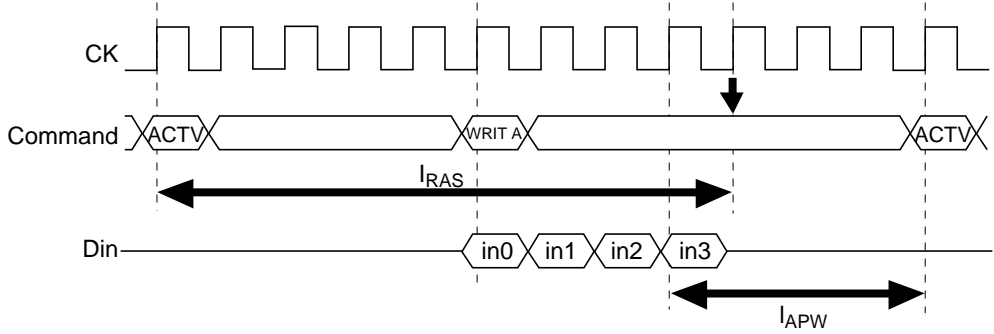

Note: Internal auto-precharge starts at the timing indicated by "↓".
and an interval of t_{RAS} (I_{RAS}) is required between previous active (ACTV) command and internal precharge "↓".

Single Write

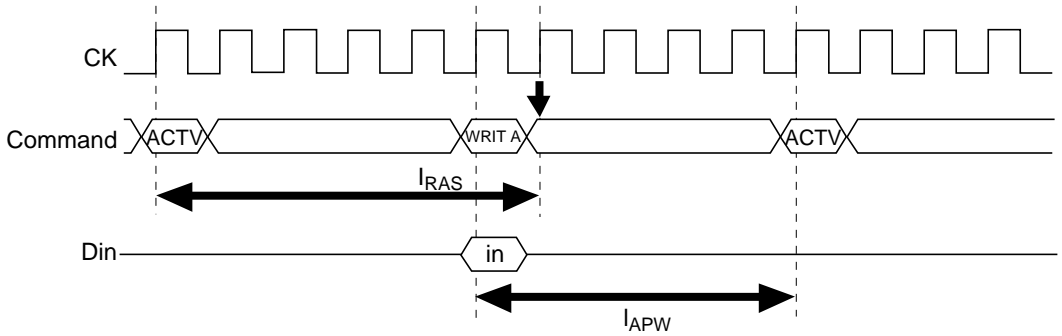

Note: Internal auto-precharge starts at the timing indicated by "↓".
and an interval of t_{RAS} (I_{RAS}) is required between previous active (ACTV) command and internal precharge "↓".

Full-page Burst Stop

Burst stop command during burst read: The burst stop (BST) command is used to stop data output during a full-page burst. The BST command sets the output buffer to High-Z and stops the full-page burst read. The timing from command input to the last data changes depending on the \overline{CE} latency setting. In addition, the BST command is valid only during full-page burst mode, and is invalid with burst lengths 1, 2, 4 and 8.

\overline{CE} latency	BST to valid data	BST to high impedance
2	1	2
3	2	3

\overline{CE} Latency = 2, Burst Length = full page

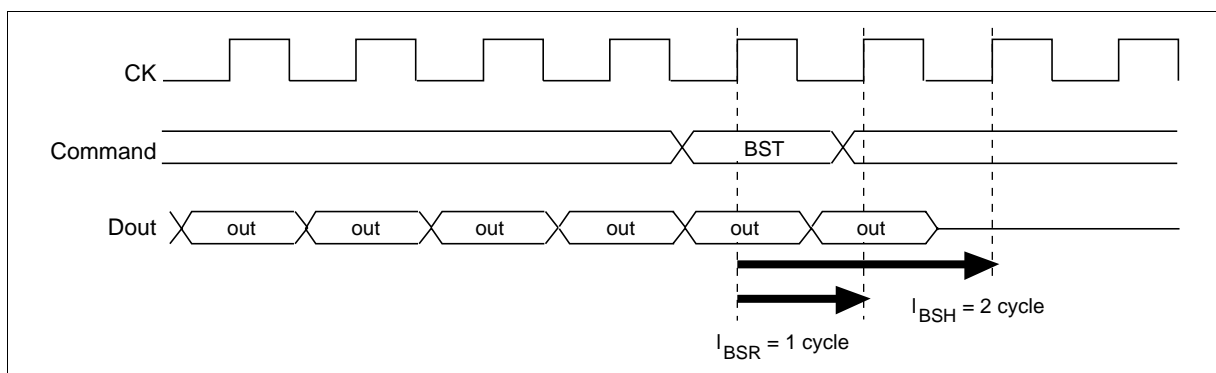

\overline{CE} Latency = 3, Burst Length = full page

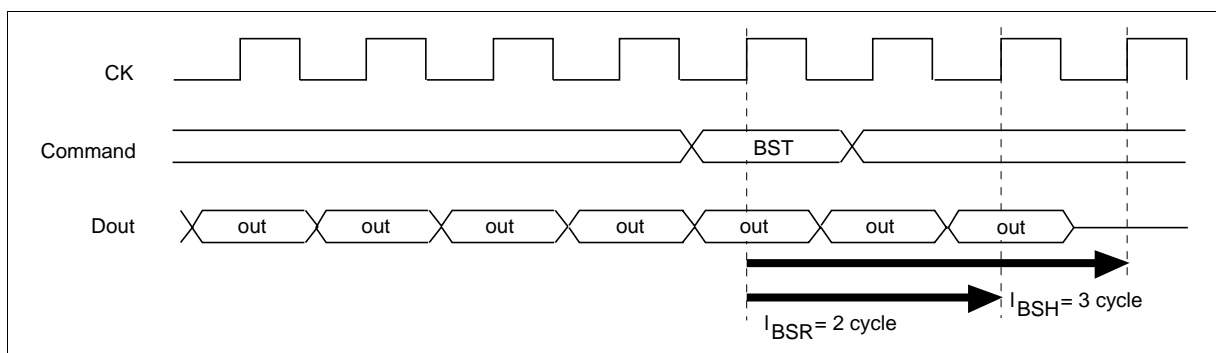

Burst stop command at burst write: The burst stop command (BST command) is used to stop data input during a full-page burst write. No data is written in the same clock as the BST command and in subsequent clocks. In addition, the BST command is only valid during full-page burst mode, and is invalid with burst lengths of 1, 2, 4 and 8. And an interval of t_{DPL} is required between last data-in and the next precharge command.

Burst Length = full page

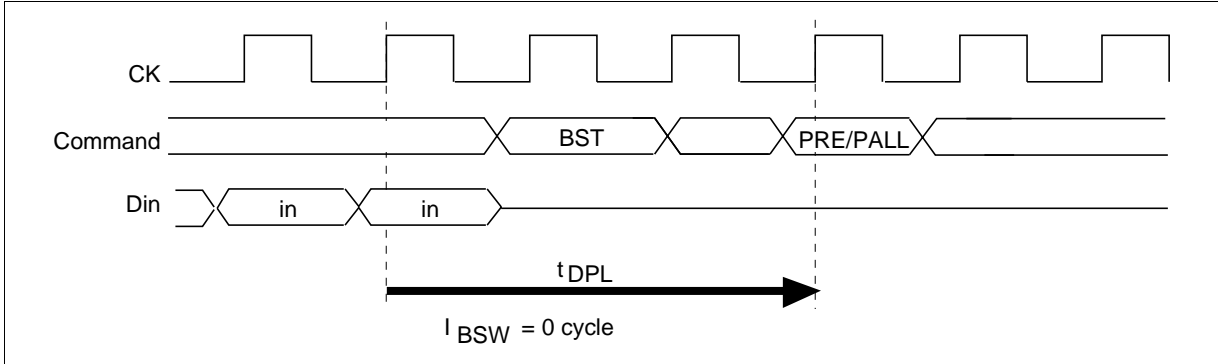

Command Intervals

Read command to Read command interval:

1. Same bank, same ROW address: When another read command is executed at the same ROW address of the same bank as the preceding read command execution, the second read can be performed after an interval of no less than 1 clock. Even when the first command is a burst read that is not yet finished, the data read by the second command will be valid.

READ to READ Command Interval (same ROW address in same bank)

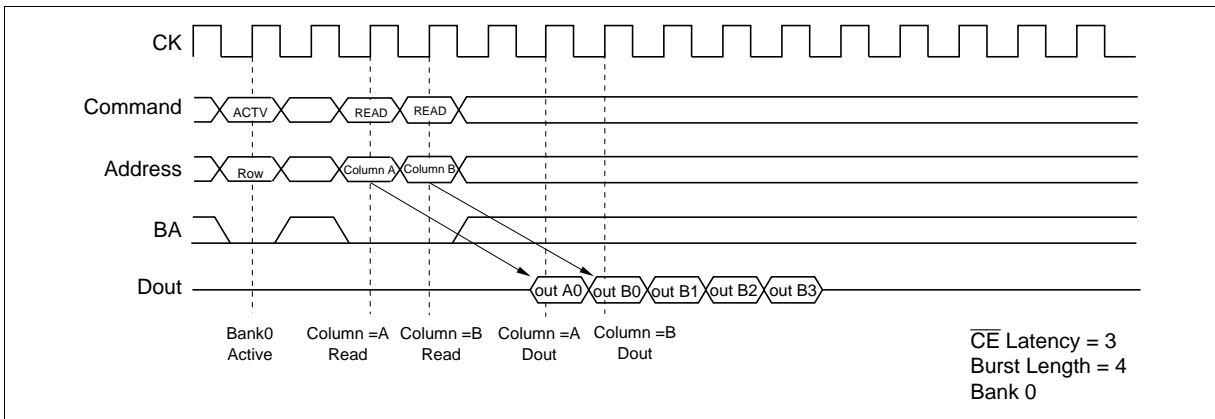

2. Same bank, different ROW address: When the ROW address changes on same bank, consecutive read commands cannot be executed; it is necessary to separate the two read commands with a precharge command and a bank-active command.

3. Different bank: When the bank changes, the second read can be performed after an interval of no less than 1 clock, provided that the other bank is in the bank-active state. Even when the first command is a burst read that is not yet finished, the data read by the second command will be valid.

READ to READ Command Interval (different bank)

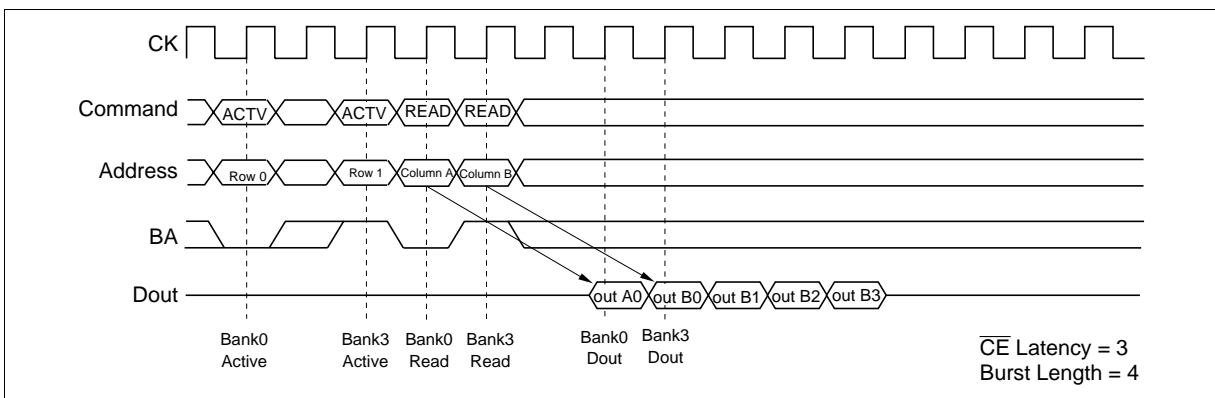

Write command to Write command interval:

1. Same bank, same ROW address: When another write command is executed at the same ROW address of the same bank as the preceding write command, the second write can be performed after an interval of no less than 1 clock. In the case of burst writes, the second write command has priority.

WRITE to WRITE Command Interval (same ROW address in same bank)

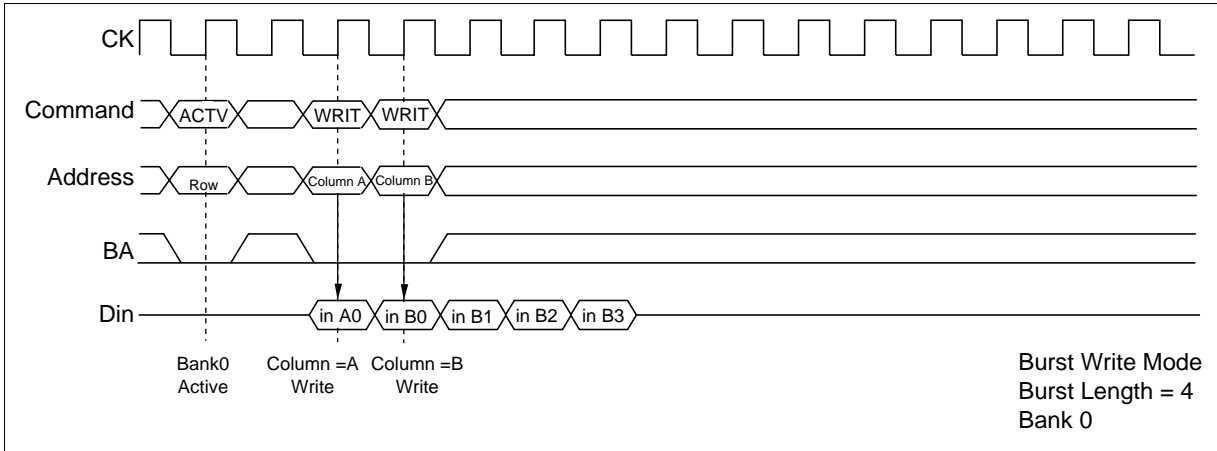

2. Same bank, different ROW address: When the ROW address changes, consecutive write commands cannot be executed; it is necessary to separate the two write commands with a precharge command and a bank-active command.

3. Different bank: When the bank changes, the second write can be performed after an interval of no less than 1 clock, provided that the other bank is in the bank-active state. In the case of burst write, the second write command has priority.

WRITE to WRITE Command Interval (different bank)

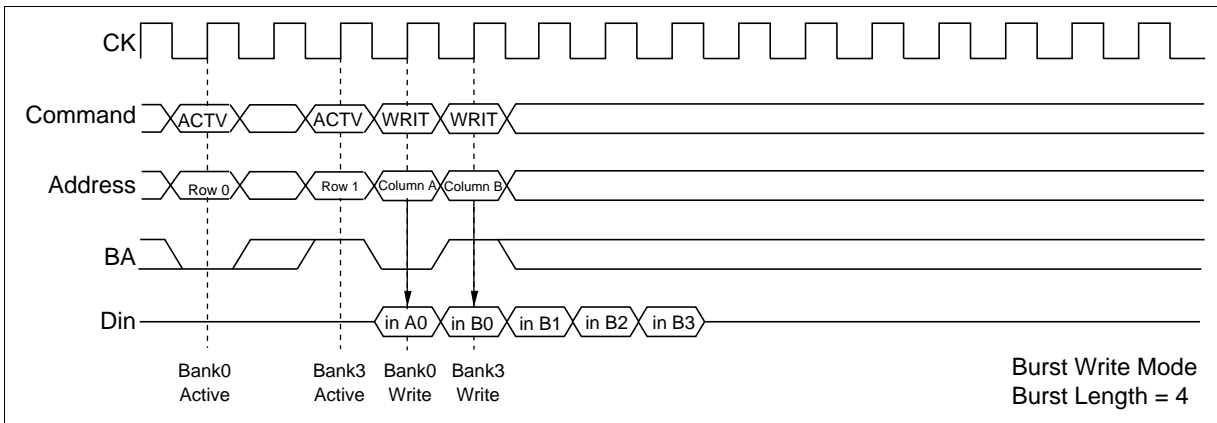

Read command to Write command interval:

1. Same bank, same ROW address: When the write command is executed at the same ROW address of the same bank as the preceding read command, the write command can be performed after an interval of no less than 1 clock. However, DQMB must be set High so that the output buffer becomes High-Z before data input.

READ to WRITE Command Interval (1)

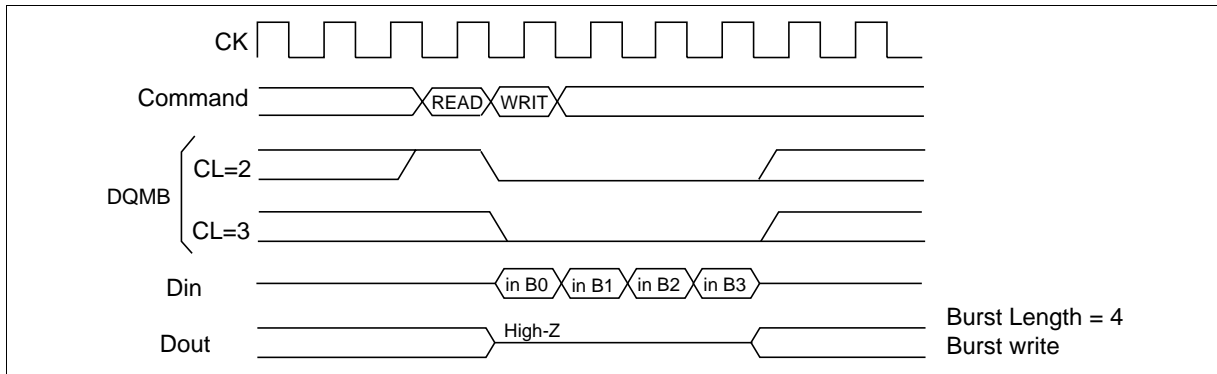

READ to WRITE Command Interval (2)

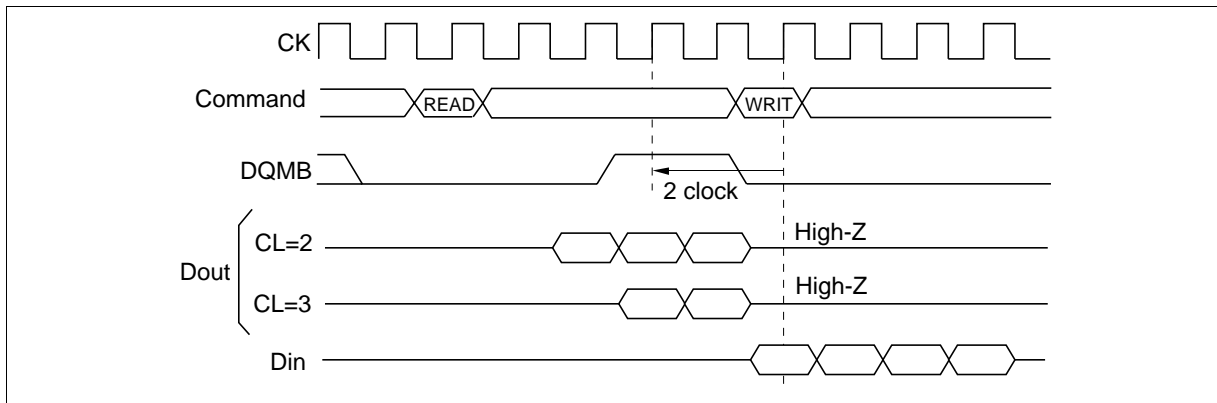

2. Same bank, different ROW address: When the ROW address changes, consecutive write commands cannot be executed; it is necessary to separate the two commands with a precharge command and a bank-active command.

3. Different bank: When the bank changes, the write command can be performed after an interval of no less than 1 clock, provided that the other bank is in the bank-active state. However, DQMB must be set High so that the output buffer becomes High-Z before data input.

Write command to Read command interval:

1. Same bank, same ROW address: When the read command is executed at the same ROW address of the same bank as the preceding write command, the read command can be performed after an interval of no less than 1 clock. However, in the case of a burst write, data will continue to be written until one cycle before the read command is executed.

WRITE to READ Command Interval (1)

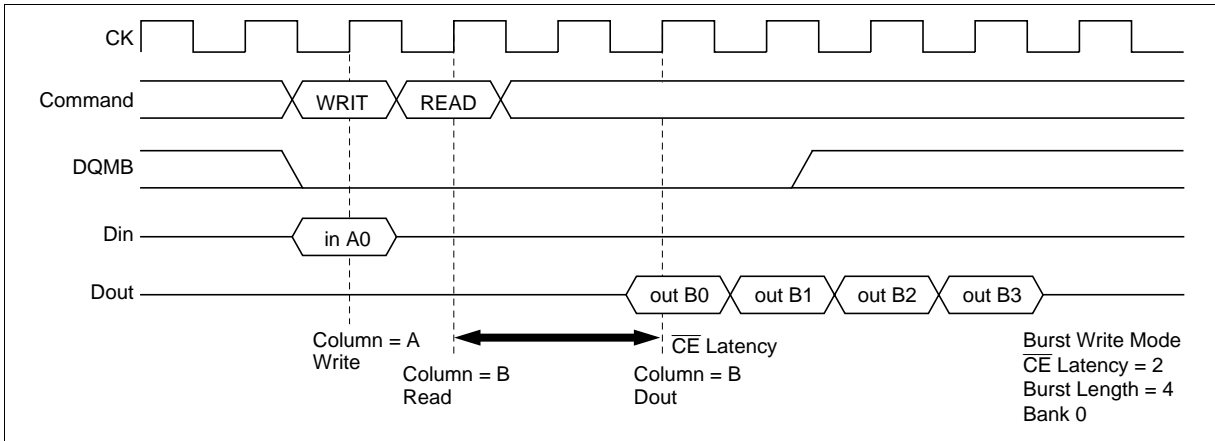

WRITE to READ Command Interval (2)

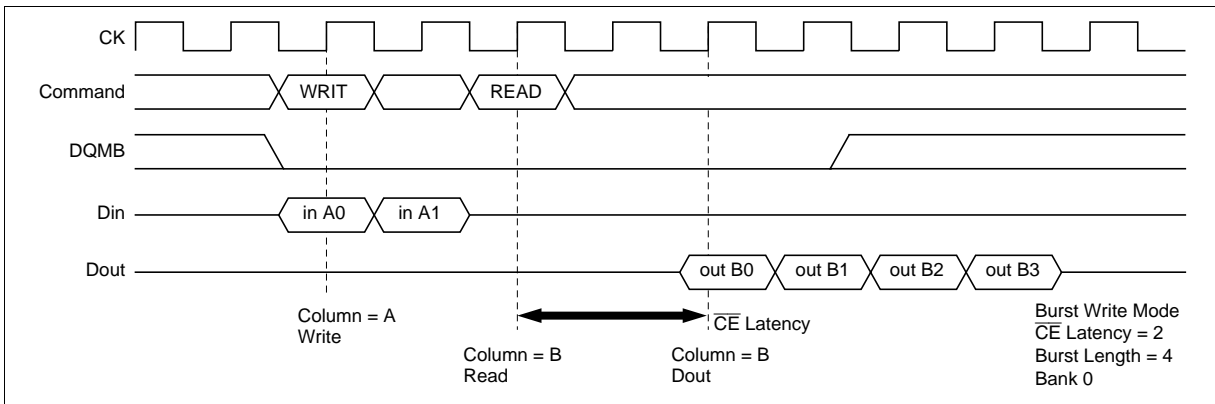

2. Same bank, different ROW address: When the ROW address changes, consecutive read commands cannot be executed; it is necessary to separate the two commands with a precharge command and a bank-active command.

3. Different bank: When the bank changes, the read command can be performed after an interval of no less than 1 clock, provided that the other bank is in the bank-active state. However, in the case of a burst write, data will continue to be written until one clock before the read command is executed (as in the case of the same bank and the same address).

Read command to Precharge command interval (same bank): When the precharge command is executed for the same bank as the read command that preceded it, the minimum interval between the two commands is one clock. However, since the output buffer then becomes High-Z after the clocks defined by I_{H2P} , there is a case of interruption to burst read data output will be interrupted, if the precharge command is input during burst read. To read all data by burst read, the clocks defined by I_{EP} must be assured as an interval from the final data output to precharge command execution.

READ to PRECHARGE Command Interval (same bank): To output all data

\overline{CE} Latency = 2, Burst Length = 4

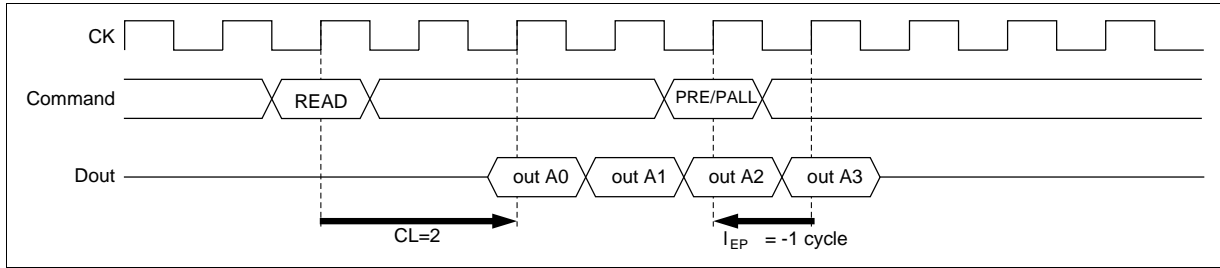

\overline{CE} Latency = 3, Burst Length = 4

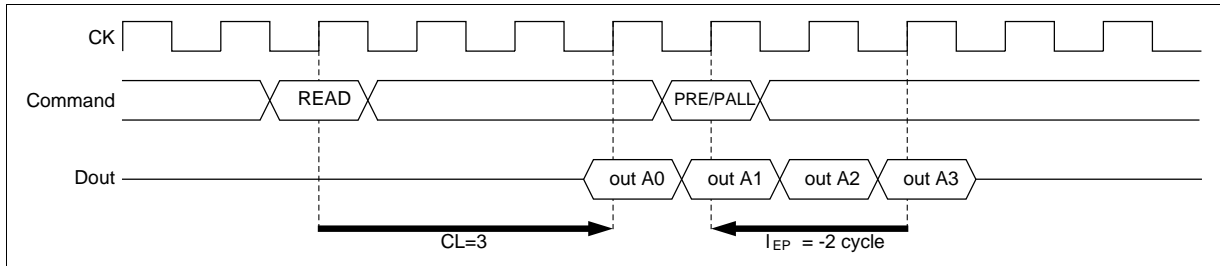

READ to PRECHARGE Command Interval (same bank): To stop output data

$\overline{\text{CE}}$ Latency = 2, Burst Length = 1, 2, 4, 8, full page burst

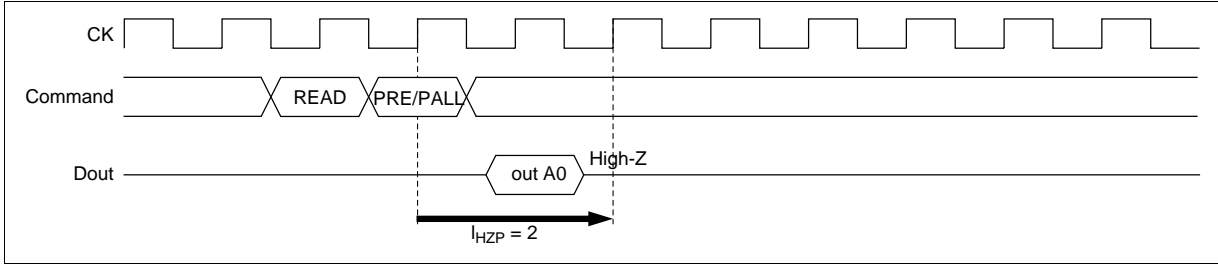

$\overline{\text{CE}}$ Latency = 3, Burst Length = 1, 2, 4, 8, full page burst

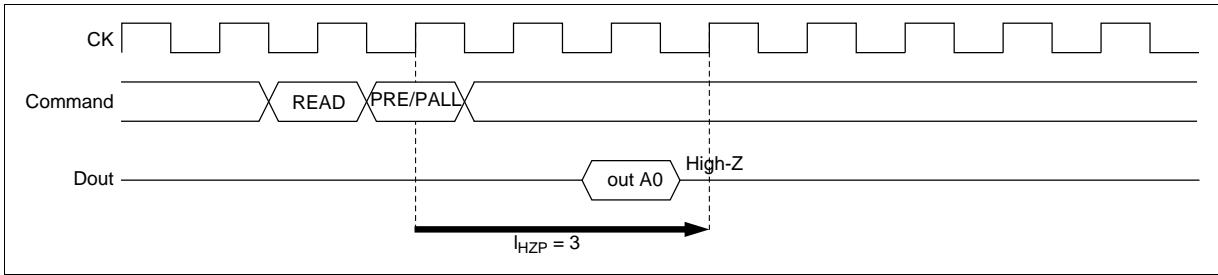

Write command to Precharge command interval (same bank): When the precharge command is executed for the same bank as the write command that preceded it, the minimum interval between the two commands is 1 clock. However, if the burst write operation is unfinished, the input data must be masked by means of DQMB for assurance of the clock defined by t_{DPL} .

WRITE to PRECHARGE Command Interval (same bank)

Burst Length = 4 (To stop write operation)

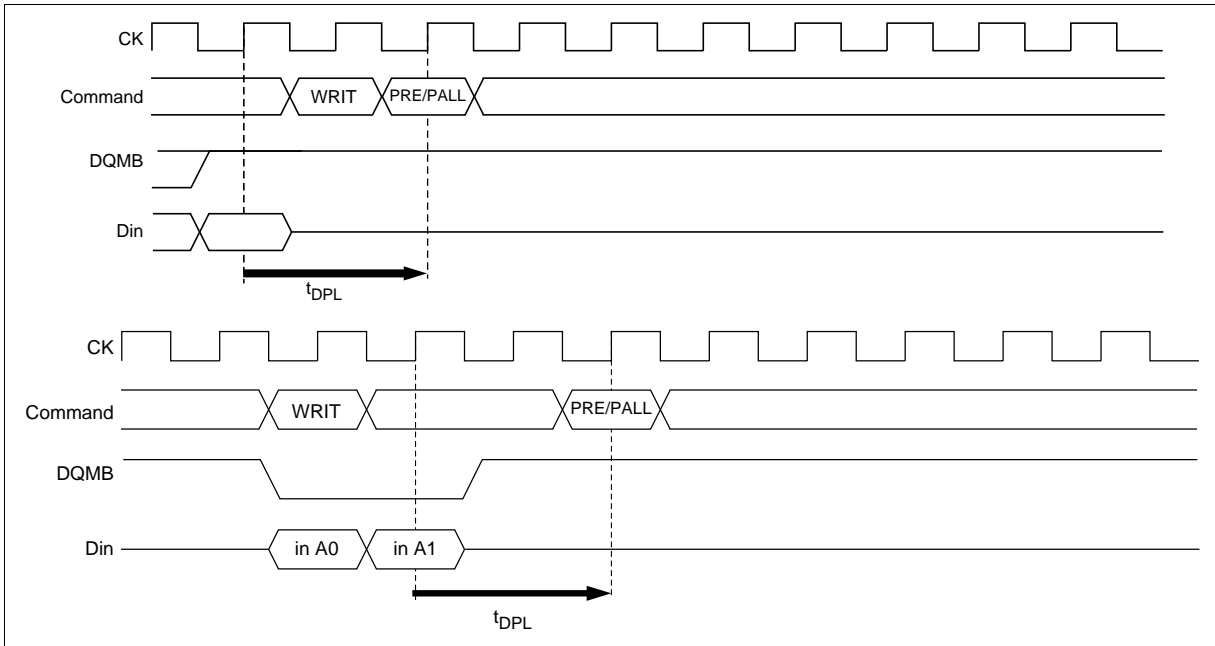

Burst Length = 4 (To write all data)

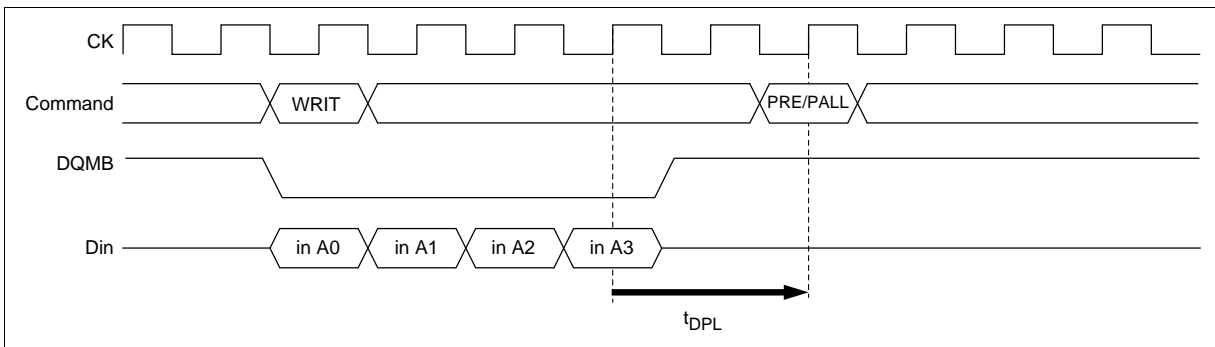

Bank active command interval:

1. **Same bank:** The interval between the two bank-active commands must be no less than t_{RC} .

Bank active to bank active for same bank

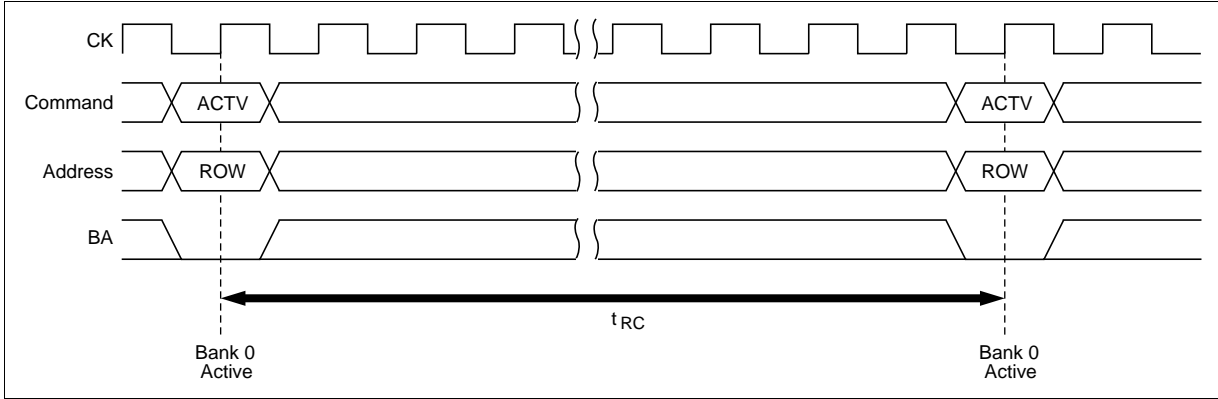

2. **In the case of different bank-active commands:** The interval between the two bank-active commands must be no less than t_{RRD} .

Bank active to bank active for different bank

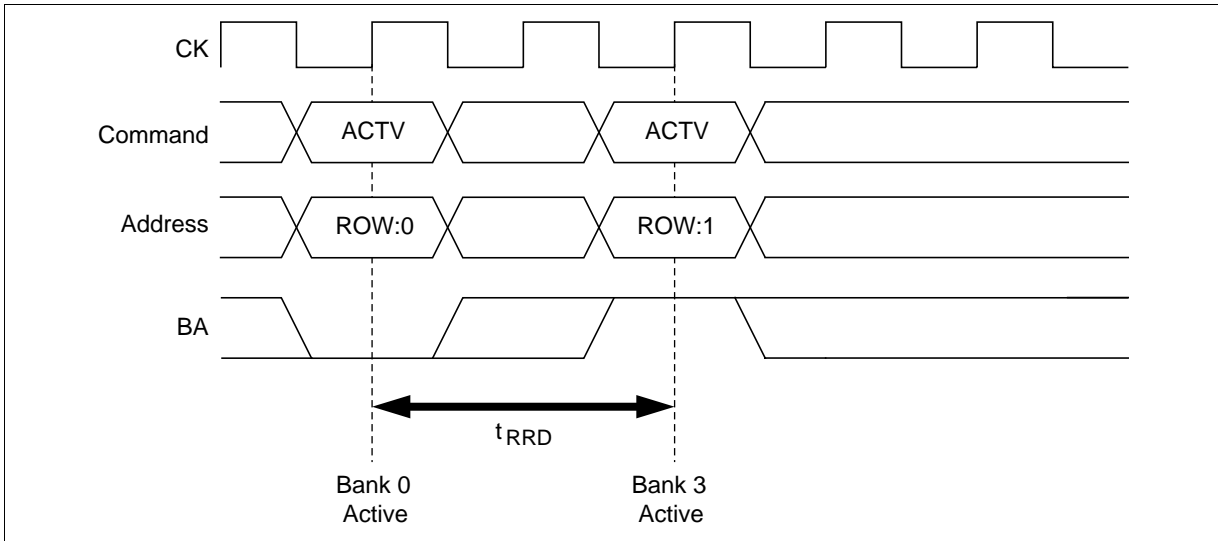

Mode register set to Bank-active command interval: The interval between setting the mode register and executing a bank-active command must be no less than t_{RSA} .

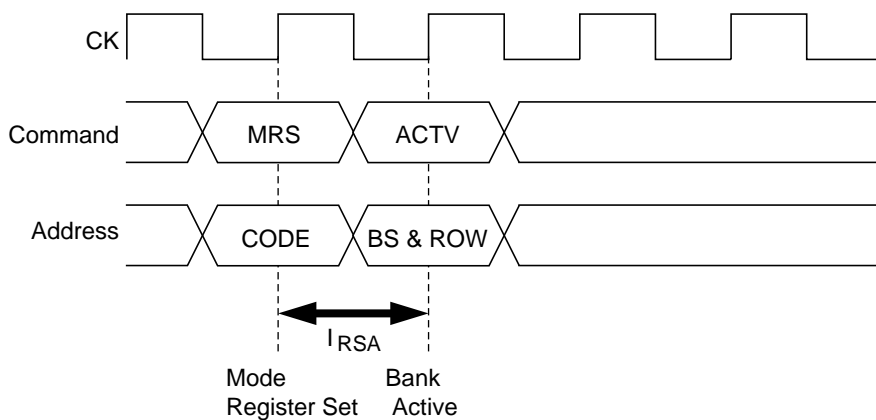

DQMB Control

The DQMB mask the lower and upper bytes of the DQ data, respectively. The timing of DQMB is different during reading and writing.

Reading: When data is read, the output buffer can be controlled by DQMB. By setting DQMB to Low, the output buffer becomes Low-Z, enabling data output. By setting DQMB to High, the output buffer becomes High-Z, and the corresponding data is not output. However, internal reading operations continue. The latency of DQMB during reading is 2 clocks.

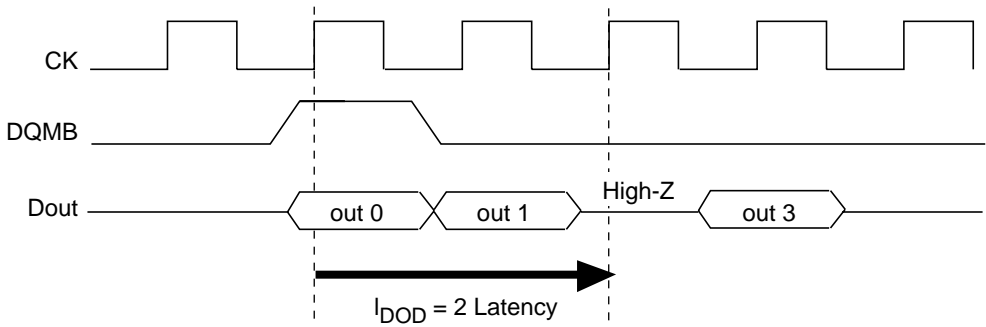

Writing: Input data can be masked by DQMB. By setting DQMB to Low, data can be written. In addition, when DQMB is set to High, the corresponding data is not written, and the previous data is held. The latency of DQMB during writing is 0 clock.

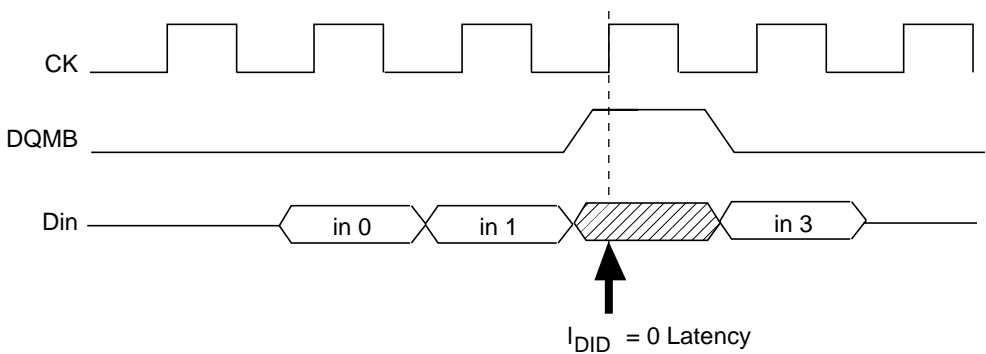

Refresh

Auto-refresh: All the banks must be precharged before executing an auto-refresh command. Since the auto-refresh command updates the internal counter every time it is executed and determines the banks and the ROW addresses to be refreshed, external address specification is not required. The refresh cycle is 4096 cycles/64 ms. (4096 cycles are required to refresh all the ROW addresses.) The output buffer becomes High-Z after auto-refresh start. In addition, since a precharge has been completed by an internal operation after the auto-refresh, an additional precharge operation by the precharge command is not required.

Self-refresh: After executing a self-refresh command, the self-refresh operation continues while CKE is held Low. During self-refresh operation, all ROW addresses are refreshed by the internal refresh timer. A self-refresh is terminated by a self-refresh exit command. Before and after self-refresh mode, execute auto-refresh to all refresh addresses in or within 64 ms period on the condition (1) and (2) below.

- (1) Enter self-refresh mode within 15.6 μ s after either burst refresh or distributed refresh at equal interval to all refresh addresses are completed.
- (2) Start burst refresh or distributed refresh at equal interval to all refresh addresses within 15.6 μ s after exiting from self-refresh mode.

Others

Power-down mode: The SDRAM module enters power-down mode when CKE goes Low in the IDLE state. In power down mode, power consumption is suppressed by deactivating the input initial circuit. Power down mode continues while CKE is held Low. In addition, by setting CKE to High, the SDRAM module exits from the power down mode, and command input is enabled from the next clock. In this mode, internal refresh is not performed.

Clock suspend mode: By driving CKE to Low during a bank-active or read/write operation, the SDRAM module enters clock suspend mode. During clock suspend mode, external input signals are ignored and the internal state is maintained. When CKE is driven High, the SDRAM module terminates clock suspend mode, and command input is enabled from the next clock. For details, refer to the “CKE Truth Table”.

Power-up sequence: The SDRAM module should be initialized by the following sequence with power up.

The CK, CKE, \bar{S} , DQMB and DQ pins keep low till power stabilizes.

The CK pin is stabilized within 100 μ s after power stabilizes before the following initialization sequence.

The CKE and DQMB is driven to high between power stabilizes and the initialization sequence.

This SDRAM module has V_{CC} clamp diodes for CK, CKE, \bar{S} DQMB and DQ pins. If these pins go high before power up, the large current flows from these pins to V_{CC} through the diodes.

Initialization sequence: When 200 μ s or more has past after the above power on, all banks must be precharged using the precharge command (PALL). After t_{RP} delay, set 8 or more auto refresh commands (REF). Set the mode register set command (MRS) to initialize the mode register. We recommend that by keeping DQM, DQMU/DQML to High, the output buffer becomes High-Z during Initialization sequence, to avoid DQ bus contention on memory system formed with a number of device.

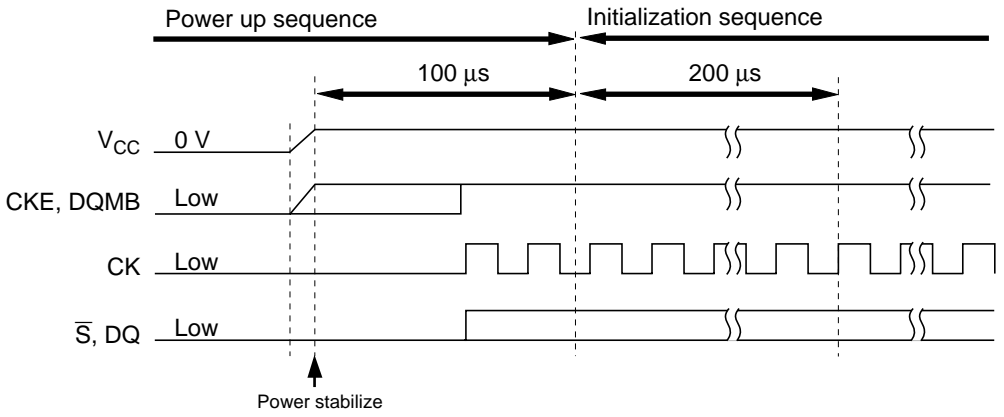

Write Cycle

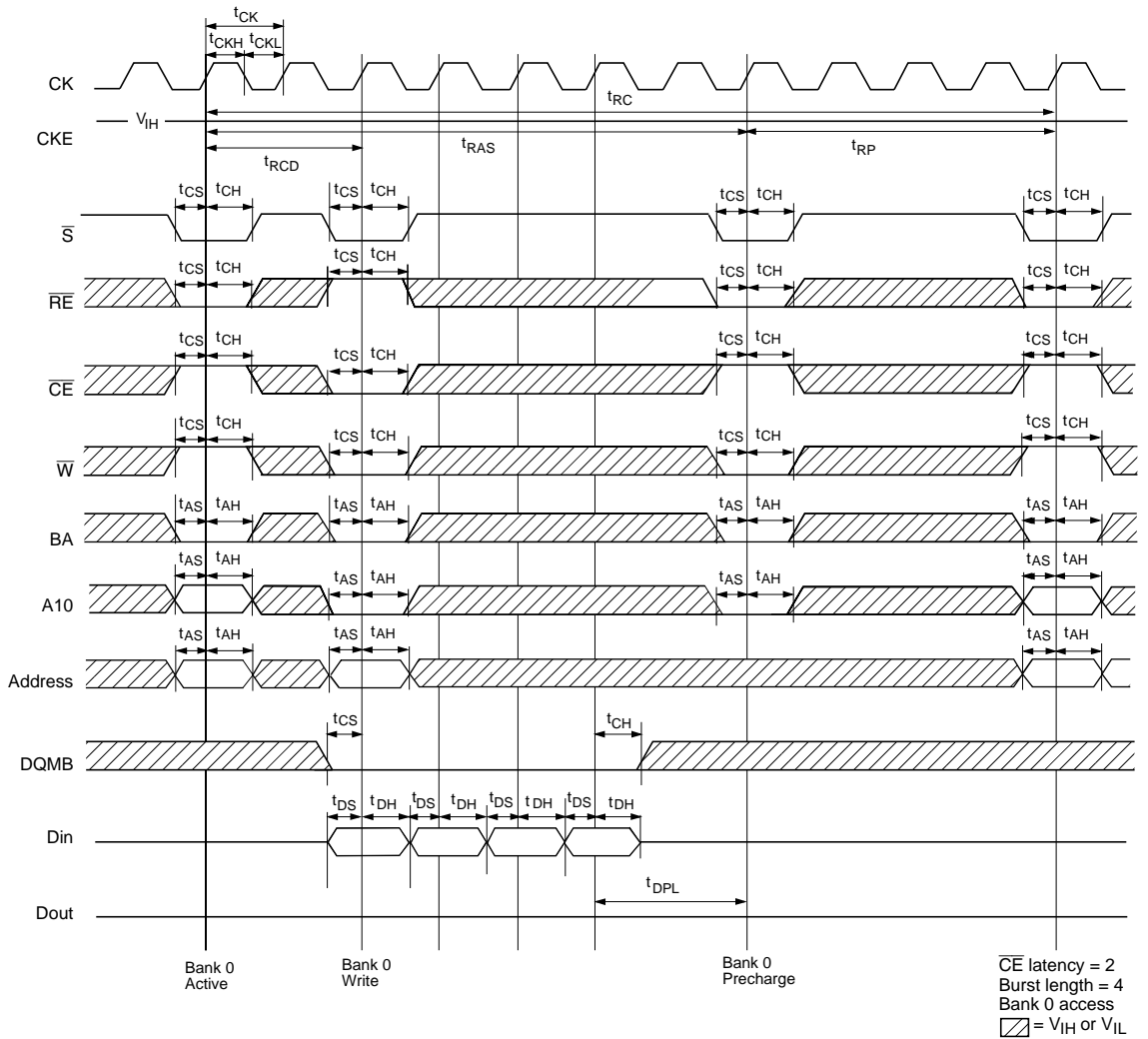

Mode Register Set Cycle

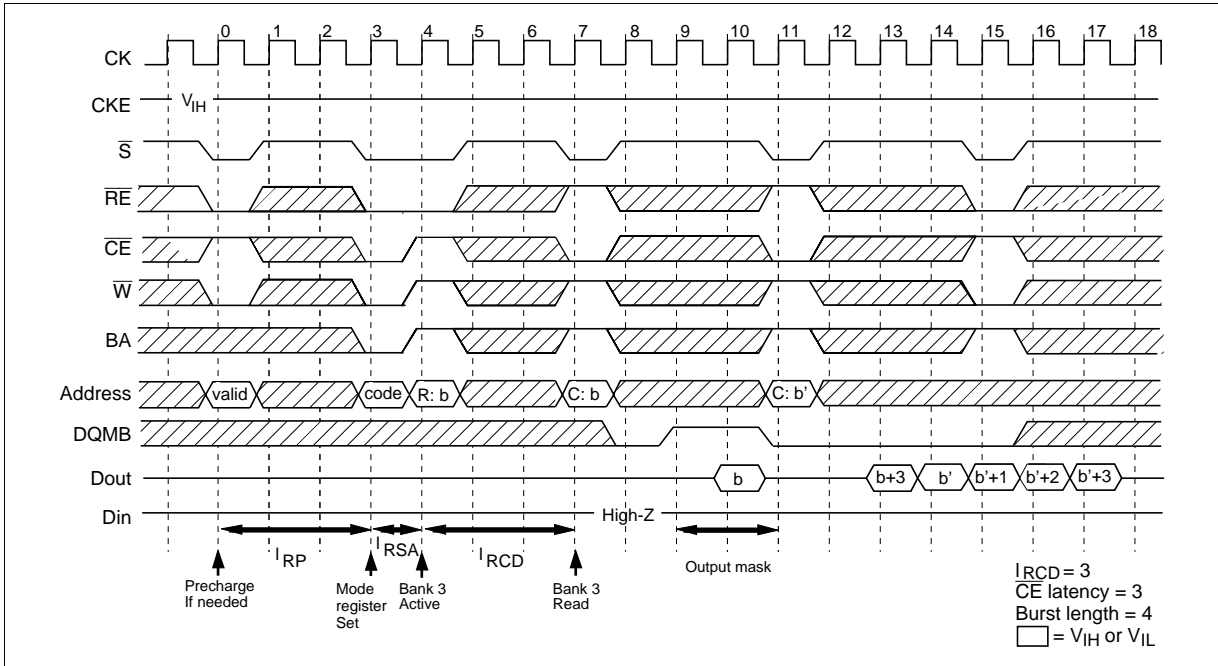

Read Cycle/Write Cycle

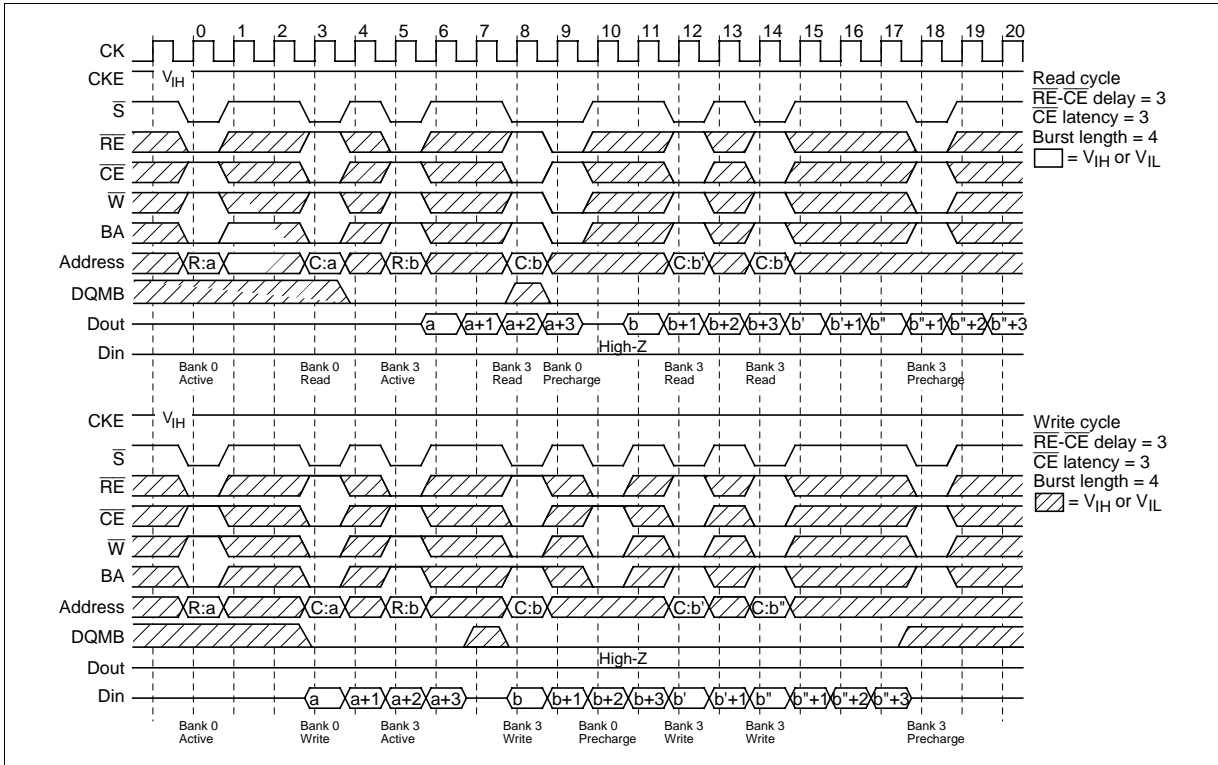

Read/Single Write Cycle

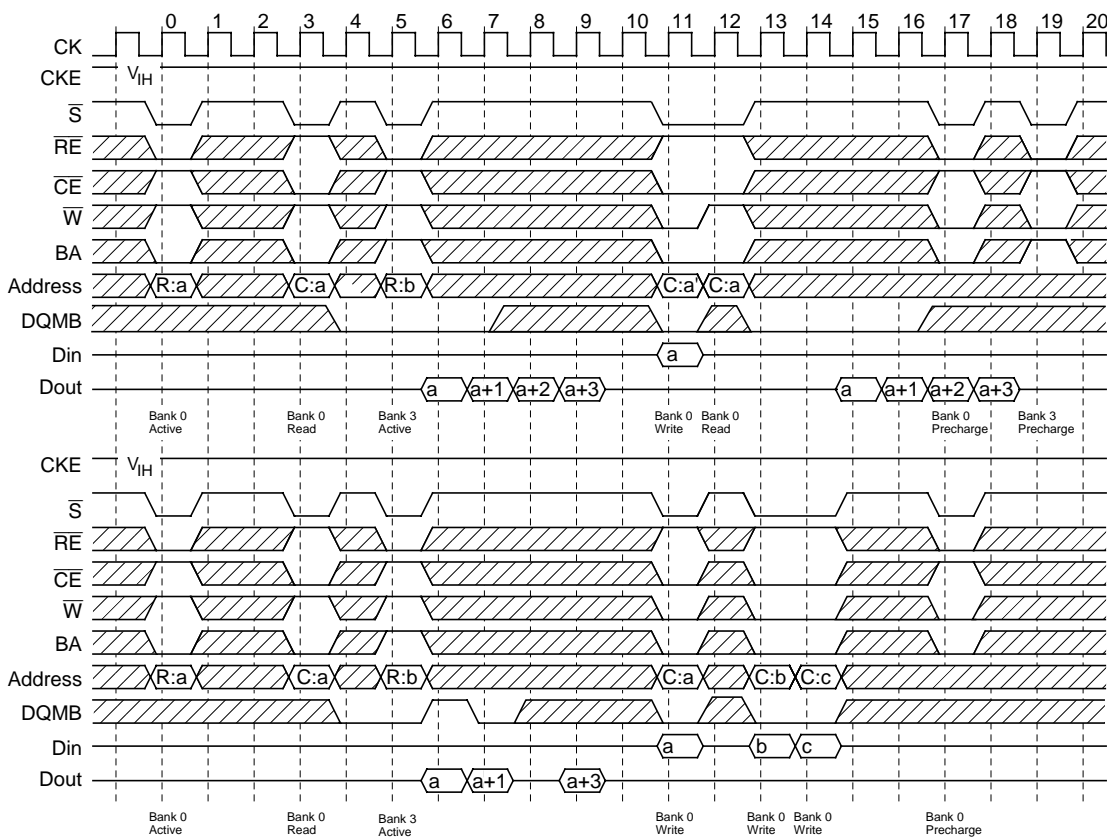

Read/Single write
 RE-CE delay = 3
 CE latency = 3
 Burst length = 4
 □ = V_{IH} or V_{IL}

Read/Burst Write Cycle

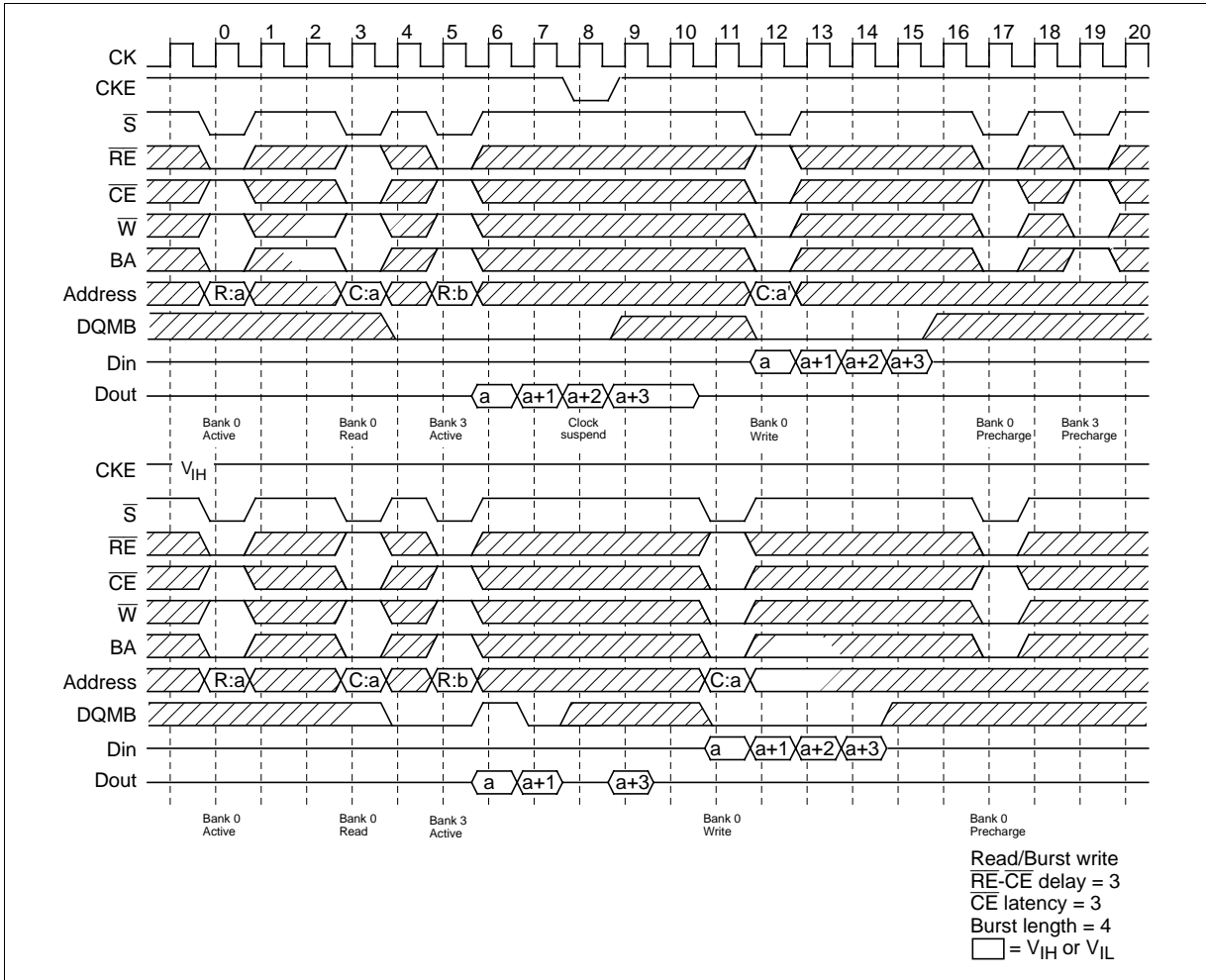

Full Page Read/Write Cycle

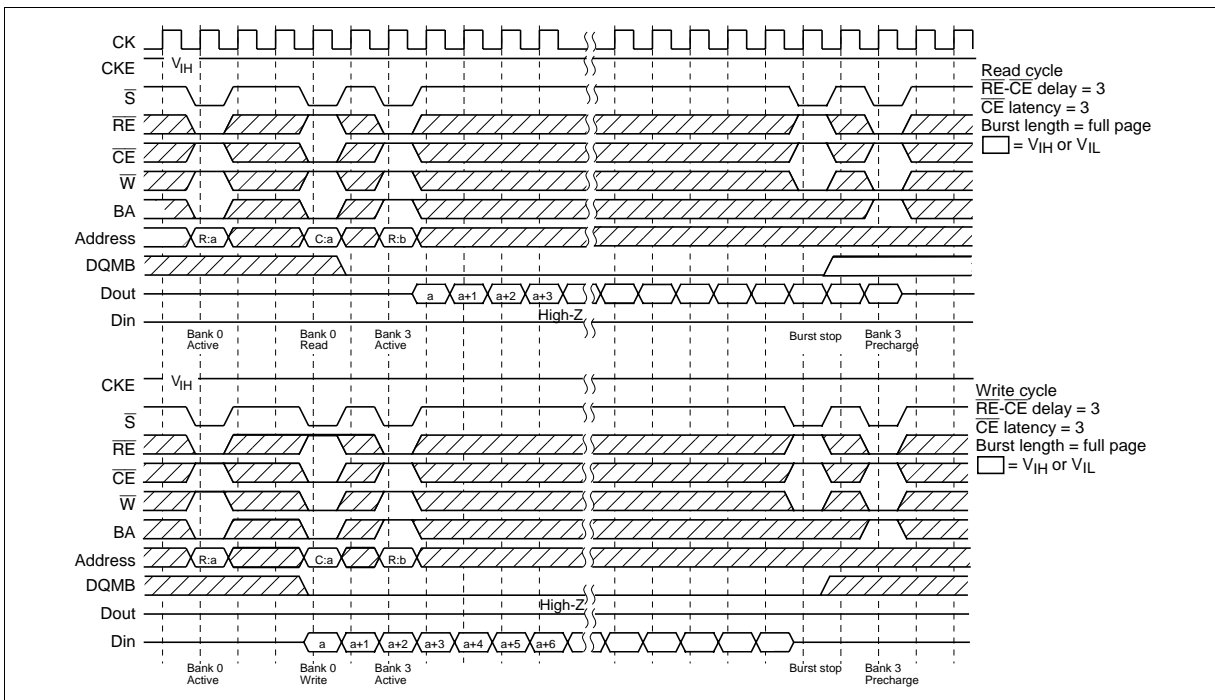

Auto Refresh Cycle

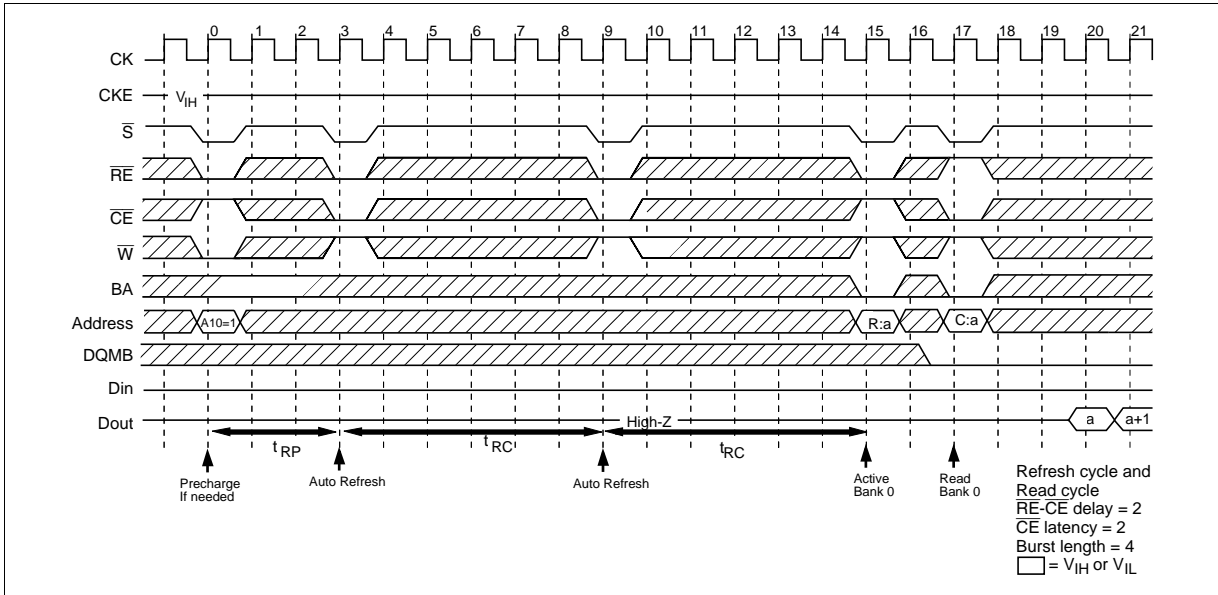

Self Refresh Cycle

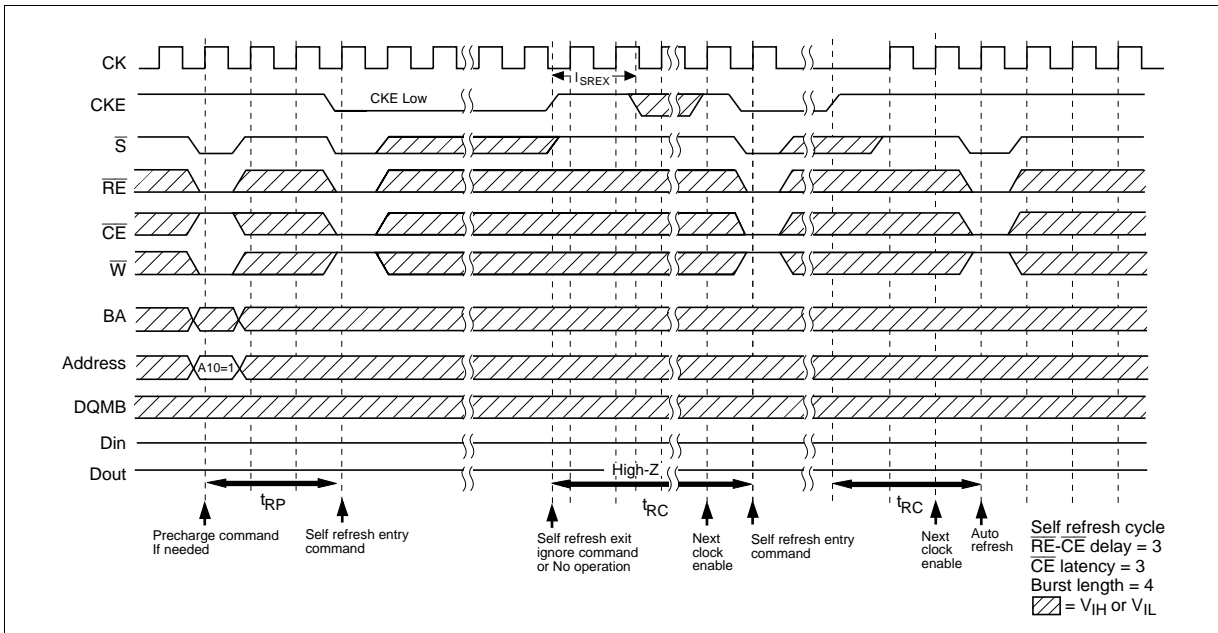

Clock Suspend Mode

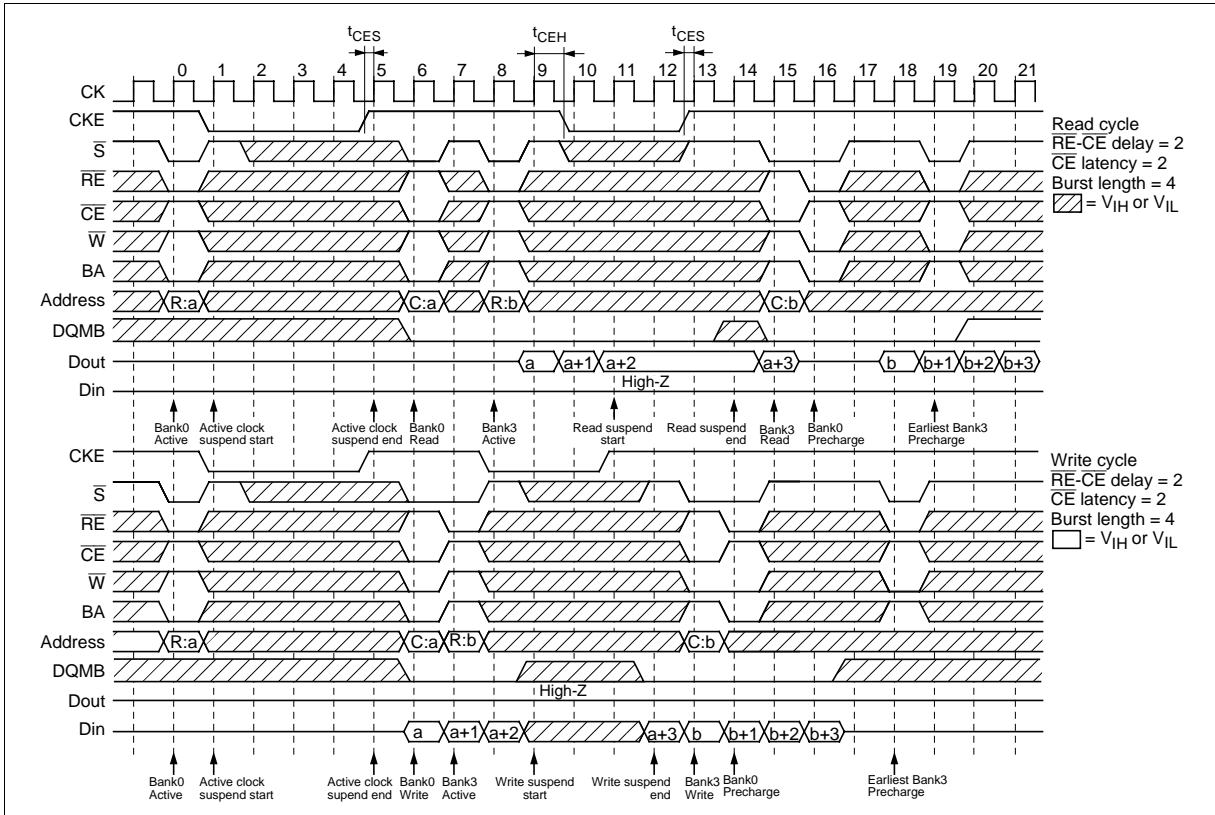

Power Down Mode

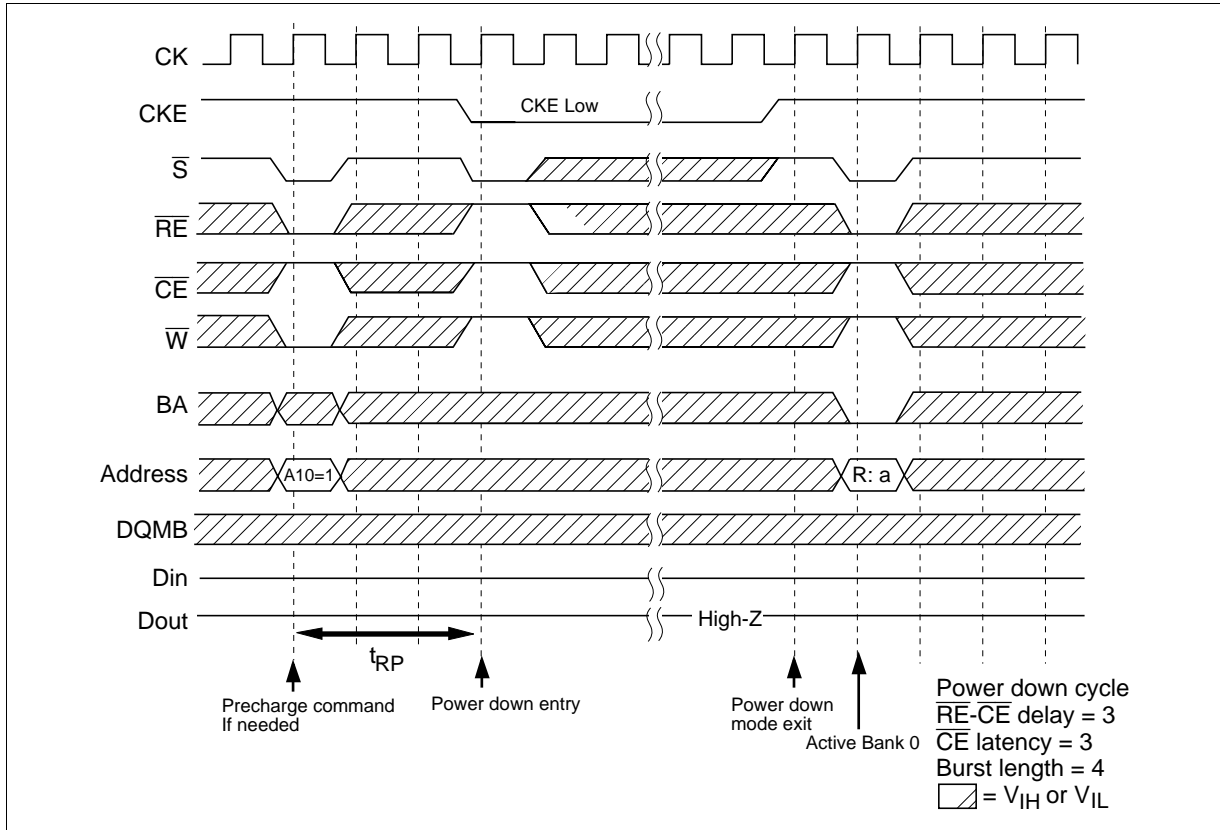

Initialization Sequence

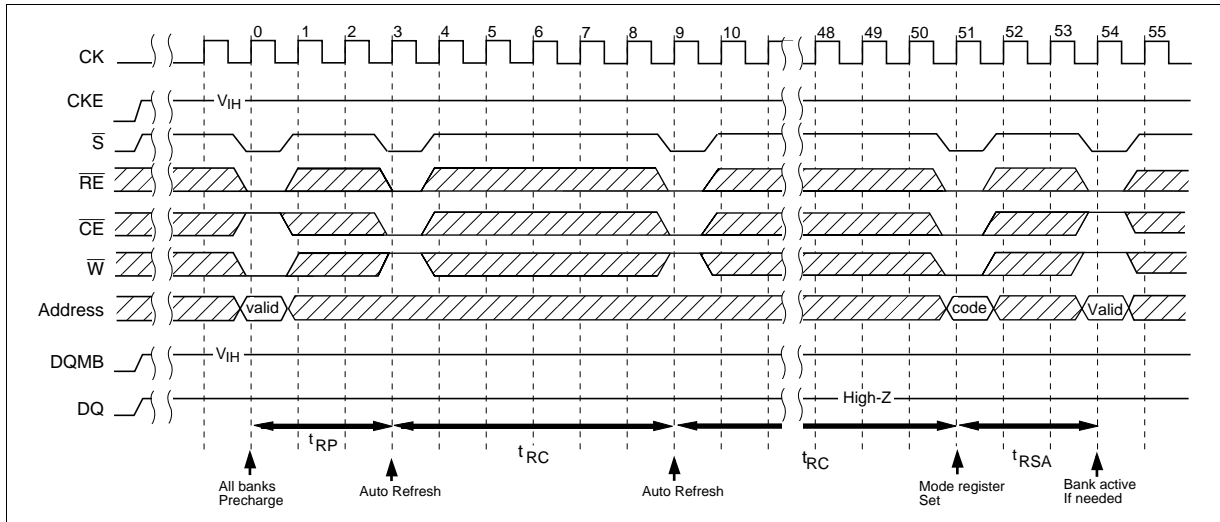

Physical Outline

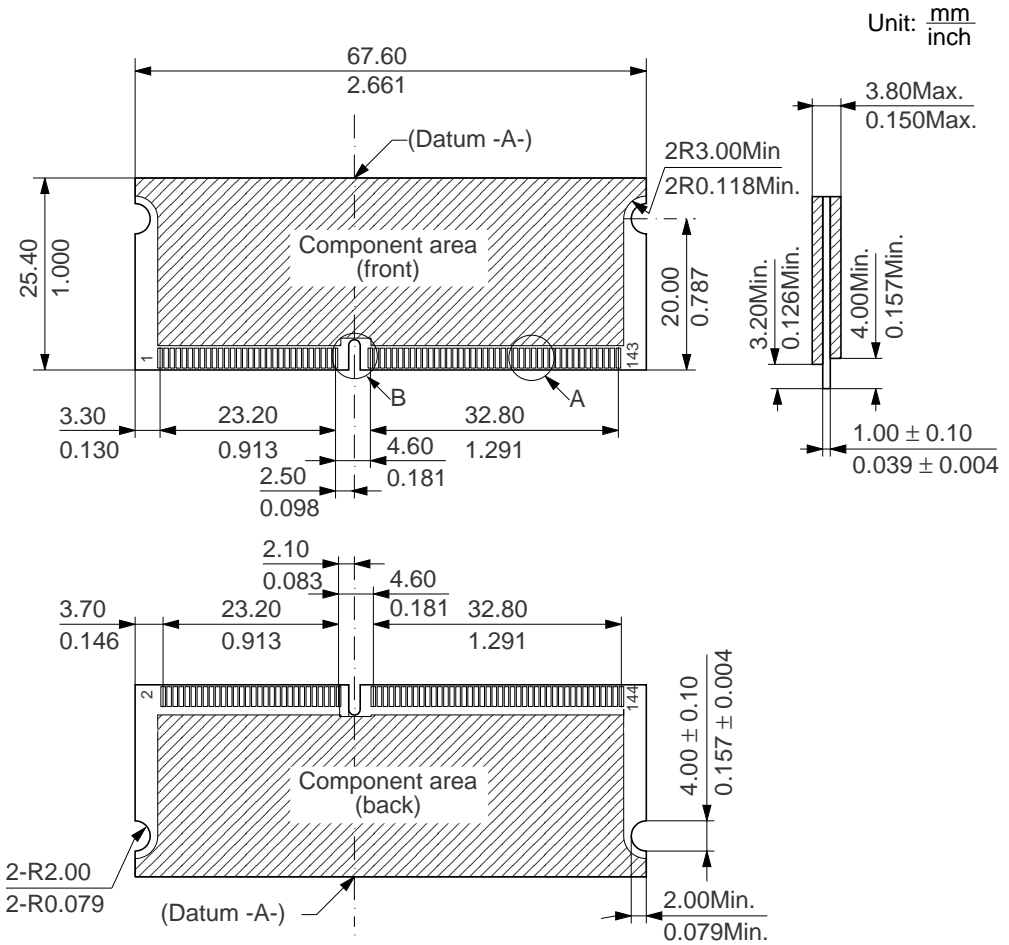

Detail A

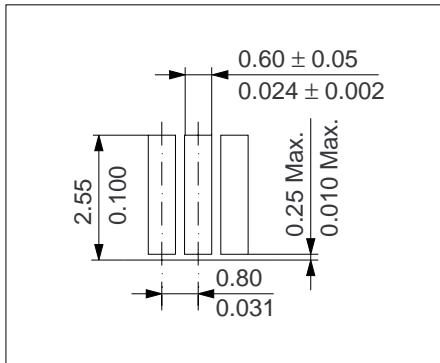

Detail B

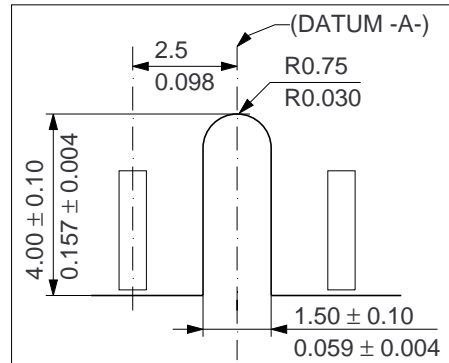

Cautions

1. Hitachi neither warrants nor grants licenses of any rights of Hitachi's or any third party's patent, copyright, trademark, or other intellectual property rights for information contained in this document. Hitachi bears no responsibility for problems that may arise with third party's rights, including intellectual property rights, in connection with use of the information contained in this document.
2. Products and product specifications may be subject to change without notice. Confirm that you have received the latest product standards or specifications before final design, purchase or use.
3. Hitachi makes every attempt to ensure that its products are of high quality and reliability. However, contact Hitachi's sales office before using the product in an application that demands especially high quality and reliability or where its failure or malfunction may directly threaten human life or cause risk of bodily injury, such as aerospace, aeronautics, nuclear power, combustion control, transportation, traffic, safety equipment or medical equipment for life support.
4. Design your application so that the product is used within the ranges guaranteed by Hitachi particularly for maximum rating, operating supply voltage range, heat radiation characteristics, installation conditions and other characteristics. Hitachi bears no responsibility for failure or damage when used beyond the guaranteed ranges. Even within the guaranteed ranges, consider normally foreseeable failure rates or failure modes in semiconductor devices and employ systemic measures such as fail-safes, so that the equipment incorporating Hitachi product does not cause bodily injury, fire or other consequential damage due to operation of the Hitachi product.
5. This product is not designed to be radiation resistant.
6. No one is permitted to reproduce or duplicate, in any form, the whole or part of this document without written approval from Hitachi.
7. Contact Hitachi's sales office for any questions regarding this document or Hitachi semiconductor products.

HITACHI

Hitachi, Ltd.

Semiconductor & Integrated Circuits.

Nippon Bldg., 2-6-2, Ohite-machi, Chiyoda-ku, Tokyo 100-0004, Japan

Tel: Tokyo (03) 3270-2111 Fax: (03) 3270-5109

URL NorthAmerica : <http://semiconductor.hitachi.com/>
 Europe : <http://www.hitachi-eu.com/hel/ecg>
 Asia (Singapore) : <http://www.has.hitachi.com.sg/grp3/sicd/index.htm>
 Asia (Taiwan) : http://www.hitachi.com.tw/E/Product/SICD_Frame.htm
 Asia (HongKong) : <http://www.hitachi.com.hk/eng/bo/grp3/index.htm>
 Japan : <http://www.hitachi.co.jp/Sicd/index.htm>

For further information write to:

Hitachi Semiconductor
 (America) Inc.
 179 East Tasman Drive,
 San Jose, CA 95134
 Tel: <1> (408) 433-1990
 Fax: <1> (408) 433-0223

Hitachi Europe GmbH
 Electronic components Group
 Dornacher Straße 3
 D-85622 Feldkirchen, Munich
 Germany
 Tel: <49> (89) 9 9180-0
 Fax: <49> (89) 9 29 30 00
 Hitachi Europe Ltd.
 Electronic Components Group.
 Whitebrook Park
 Lower Cookham Road
 Maidenhead
 Berkshire SL6 8YA, United Kingdom
 Tel: <44> (1628) 585000
 Fax: <44> (1628) 778322

Hitachi Asia Pte. Ltd.
 16 Collyer Quay #20-00
 Hitachi Tower
 Singapore 049318
 Tel: 535-2100
 Fax: 535-1533

Hitachi Asia Ltd.
 Taipei Branch Office
 3F, Hung Kuo Building, No.167,
 Tun-Hwa North Road, Taipei (105)
 Tel: <886> (2) 2718-3666
 Fax: <886> (2) 2718-8180

Hitachi Asia (Hong Kong) Ltd.
 Group III (Electronic Components)
 7/F., North Tower, World Finance Centre,
 Harbour City, Canton Road, Tsim Sha Tsui,
 Kowloon, Hong Kong
 Tel: <852> (2) 735 9218
 Fax: <852> (2) 730 0281
 Telex: 40815 HITEC HX

Copyright © Hitachi, Ltd., 1998. All rights reserved. Printed in Japan.

Revision Record

Rev.	Date	Contents of Modification	Drawn by	Approved by
0.0	Sep. 3, 1999	Initial issue (referred to HM5264165F/HM5264805F/HM5264405F rev 0.0)	S. Tsukui	K. Tsuneda
1.0	Jan. 24, 2000	(referred to HM5264165F/HM5264805F/HM5264405F rev 0.0) CKE Truth Table Clock suspend mode entry (\bar{S}): H to × DC Characteristics I_{CC1} max (CL = 2): 1120 mA to 960 mA I_{CC1} max (CL = 3): 1120 mA to 960 mA I_{CC2P} max: 48 mA to 24 mA I_{CC2PS} max: 32 mA to 16 mA I_{CC2N} max: 256 mA to 160 mA I_{CC3N} max: 320 mA to 288mA I_{CC4} max (CL = 2): 1120 mA to 880 mA I_{CC4} max (CL = 3): 1120 mA to 880 mA I_{CC5} max: 1840 mA to 1760 mA Physical Outline: Correct error		