

## CDSX400B

RoHS Device



### Features

- Designed for mounting on small surface.
- Extremely thin/leadless package.
- Low leakage current.
- High mounting capability, strong surge withstand, high reliability.

### Mechanical data

- Case: SOD-923 standard package, molded plastic.
- Terminals: solderable per MIL-STD-750 method 2026.
- Polarity: Indicated by cathode band.
- Mounting position: Any

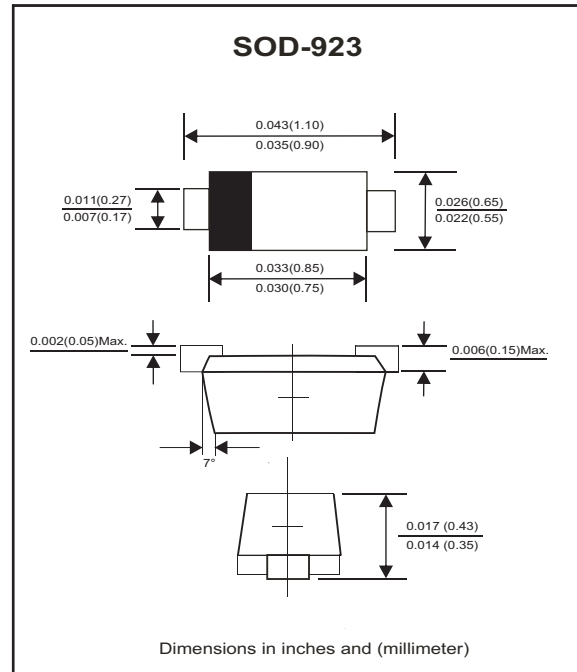

### Maximum Ratings (at TA=25°C unless otherwise noted)

Parameter	Conditions	Symbol	Min	Typ	Max	Unit
Repetitive peak reverse voltage		VRRM			90	V
Reverse voltage		VR			80	V
Average forward current		Io			100	mA
Forward current,surge peak	8.3 ms single half sine-wave superimposed on rate load ( JEDEC method)	IFSM		500		mA
Repetitive peak forward current		IFRM			225	mA
Power Dissipation		PD			125	mW
Storage temperature		TSTG	-55		+150	°C
Junction temperature		Tj			+150	°C

### Electrical Characteristics (at TA=25°C unless otherwise noted)

Parameter	Conditions	Symbol	Min	Typ	Max	Unit
Forward voltage	IF = 100 mA	VF			1.2	V
Reverse current	VR = 80 V	IR			0.1	uA
Capacitance between terminals	f = 1 MHz, and 0.5VDC reverse voltage	CT		3		pF
Reverse recovery time	VR = 6V ,IF =10 mA, RL =100 ohms	Trr		4		nS

## RATING AND CHARACTERISTIC CURVES (CDSX400B )

Fig.1 - Forward characteristics

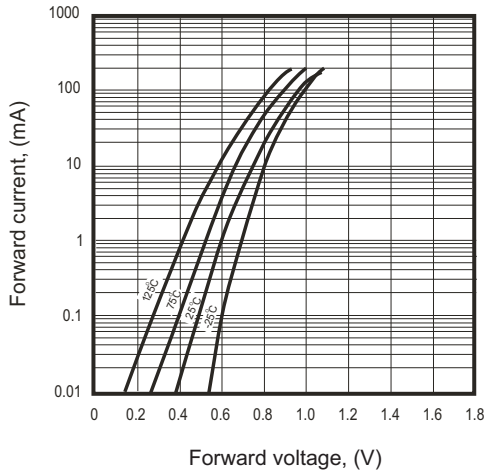

Fig.2 - Reverse characteristics

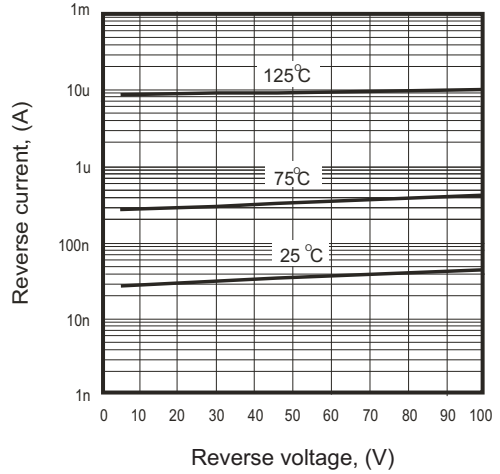

Fig.3 - Capacitance between terminals characteristics

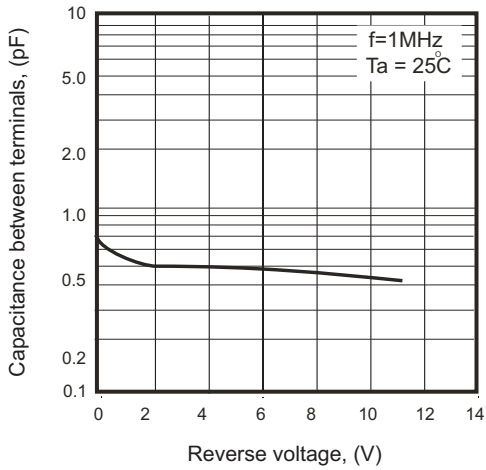

Fig.4 - Current derating curve characteristics

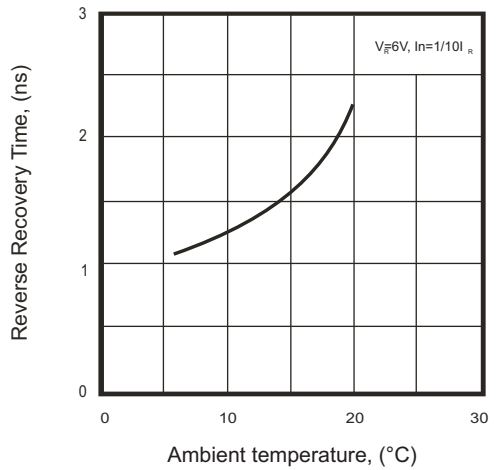

Fig.5 - Surge current characteristics

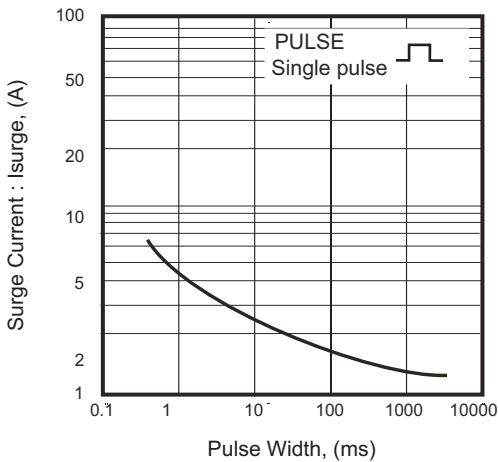
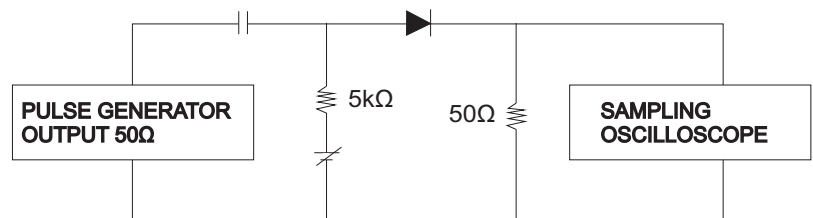
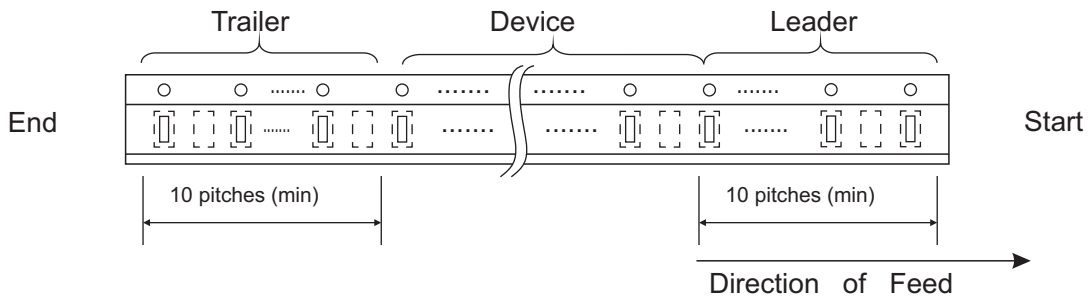
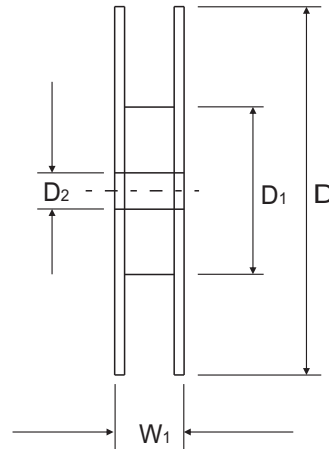
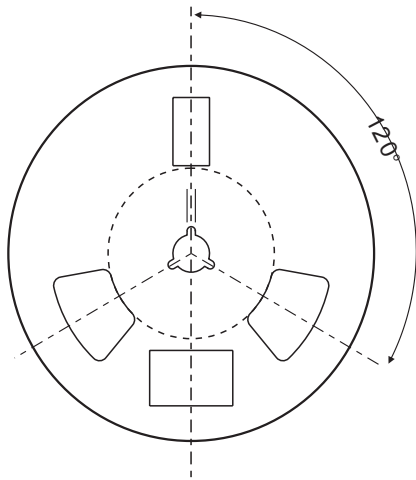
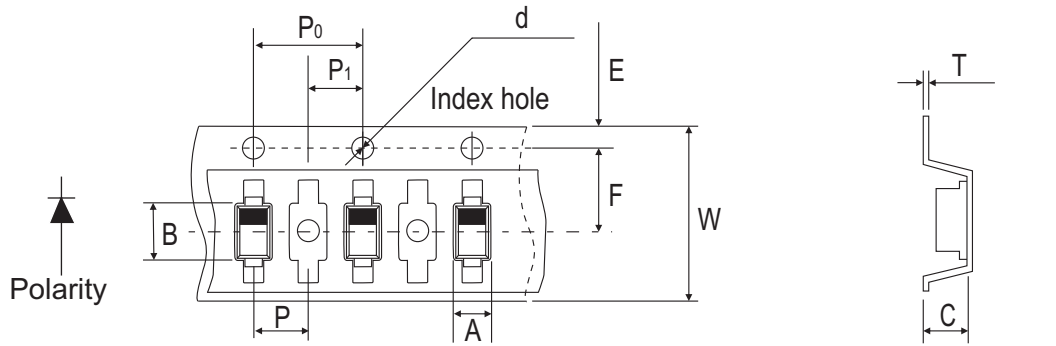

Fig.6 - Reverse recovery time (trr) measurement circuit surge current



## Reel Taping Specification



SOD-923	SYMBOL	A	B	C	d	D	D <sub>1</sub>	D <sub>2</sub>
	(mm)	0.68 ± 0.05	1.32 ± 0.05	0.46 ± 0.05	1.55 ± 0.10	178 ± 1	54.4 ± 0.4	1.30 ± 0.05
	(inch)	0.027 ± 0.002	0.052 ± 0.002	0.018 ± 0.002	0.061 ± 0.004	7.008 ± 0.04	2.142 ± 0.02	0.512 ± 0.002

SOD-923	SYMBOL	E	F	P	P <sub>0</sub>	P <sub>1</sub>	T	W	W <sub>1</sub>
	(mm)	1.75 ± 0.10	3.50 ± 0.05	2.00 ± 0.05	4.00 ± 0.10	2.00 ± 0.05	0.20 ± 0.02	8.00 ± 0.15	12.3 ± 1.00
	(inch)	0.069 ± 0.004	0.138 ± 0.002	0.079 ± 0.002	0.157 ± 0.004	0.079 ± 0.002	0.008 ± 0.001	0.315 ± 0.006	0.484 ± 0.040

## Marking Code

Part Number	Marking Code
CDSX400B	L



## Suggested PAD Layout

SIZE	SOD-923	
	(mm)	(inch)
A	0.80	0.031
B	0.50	0.020
C	0.62	0.024
D	1.30	0.051
E	0.30	0.012

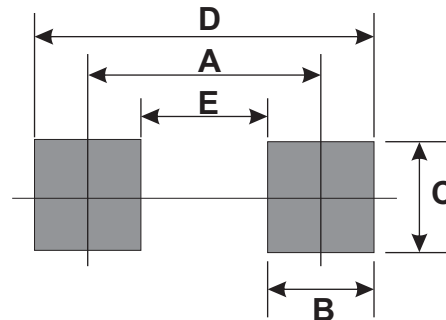

## Standard Packaging

Case Type	REEL PACK	
	REEL ( pcs )	Reel Size (inch)
SOD-923	3,000	7