

GSC1815

NPN EPITAXIAL PLANAR TRANSISTOR

Description

The GSC1815 is designed for use in driver stage of AF amplifier and general purpose applications.

Features

*Complementary to GSA1015

Package Dimensions

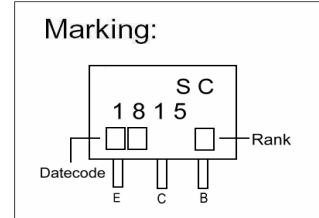
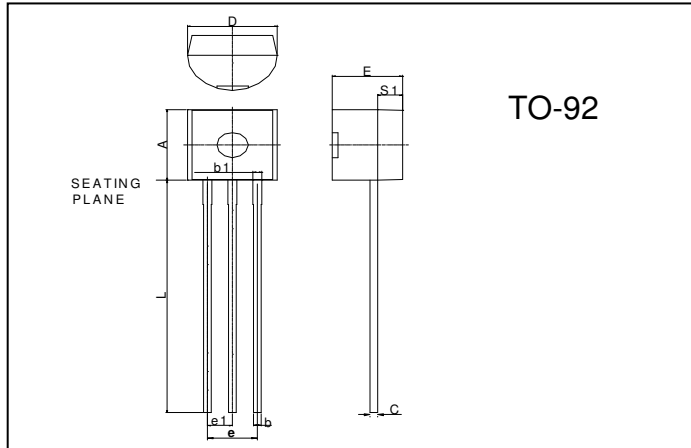

REF.	Millimeter		REF.	Millimeter	
	Min.	Max.		Min.	Max.
A	4.45	4.7	D	4.44	4.7
S1	1.02	-	E	3.30	3.81
b	0.36	0.51	L	12.70	-
b1	0.36	0.76	e1	1.150	1.390
C	0.36	0.51	e	2.42	2.66

Absolute Maximum Ratings at Ta = 25°C

Parameter	Symbol	Ratings	Unit
Junction Temperature	Tj	+150	°C
Storage Temperature	Tstg	-55 ~ +150	°C
Collector to Base Voltage	VCBO	60	V
Collector to Emitter Voltage	VCEO	50	V
Emitter to Base Voltage	VEBO	5	V
Collector Current	Ic	150	mA
Base Current	IB	50	mA
Total Power Dissipation	PD	400	mW

Characteristics at Ta = 25°C

Symbol	Min.	Typ.	Max.	Unit	Test Conditions
BVCBO	60	-	-	V	IC=100uA
BVCEO	50	-	-	V	IC=1 mA
BVEBO	5	-	-	V	IE=10uA
ICBO	-	-	100	nA	VCE=60V, IE = 0
IEBO	-	-	100	nA	VEB=5V, Ic = 0
*VCE(sat)	-	0.1	0.25	V	IC=100mA, IB=10mA
*VBE(sat)	-	-	1.0	V	IC=100mA, IB=10mA
hFE1	70	-	700		VCE=6V, IC=2mA
hFE2	25	-	-		VCE=6V, IC=150mA
fT	80	-	-	MHz	VCE=10V, IC=1mA, f=100MHz
Cob	-	-	3.0	pF	VCB=10V, IE = 0, f=1MHz

* Pulse Test: Pulse Width ≤ 380us, Duty Cycle ≤ 2%

Classification Of hFE1

Rank	O	Y	GR	L
Range	70-140	120-240	200-400	350-700

Characteristics Curve

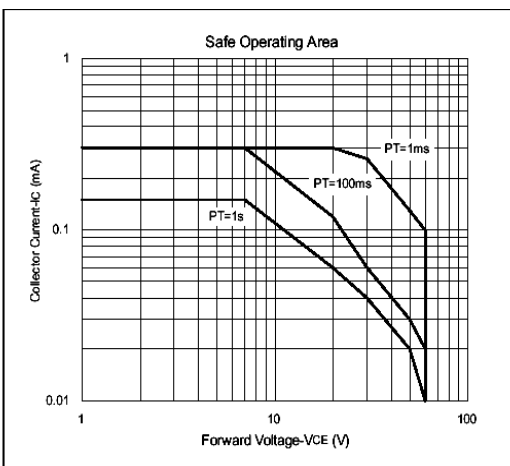
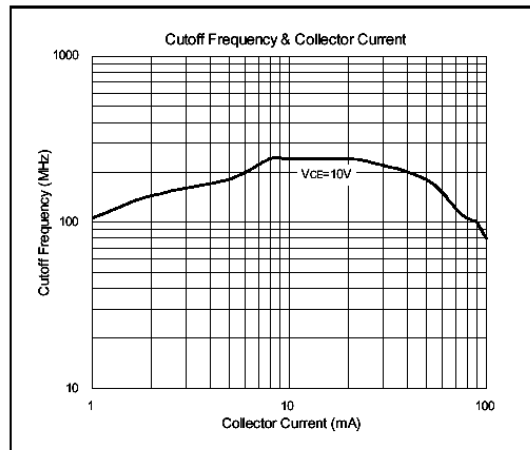
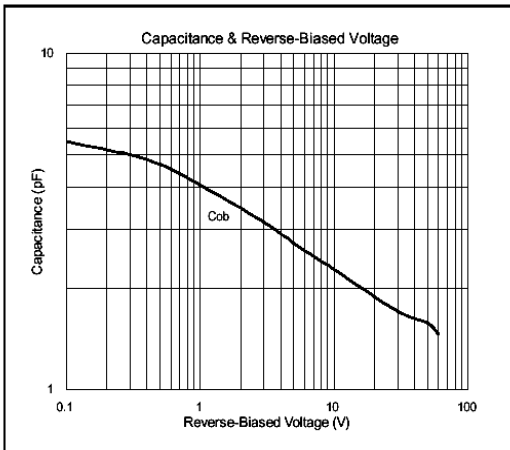
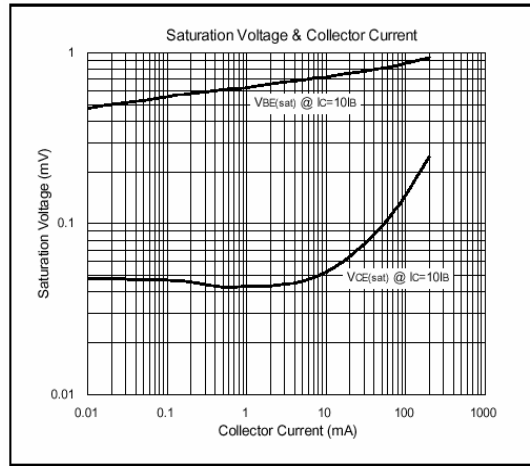
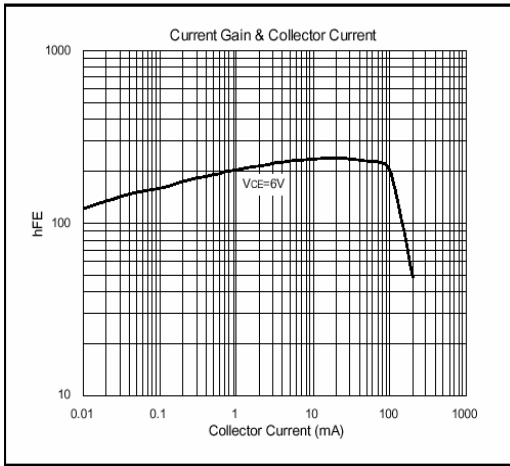

Important Notice:

- All rights are reserved. Reproduction in whole or in part is prohibited without the prior written approval of GTM.
- GTM reserves the right to make changes to its products without notice.
- GTM semiconductor products are not warranted to be suitable for use in life-support Applications, or systems.
- GTM assumes no liability for any consequence of customer product design, infringement of patents, or application assistance.

Head Office And Factory:

- Taiwan:** No. 17-1 Tatung Rd. Fu Kou Hsin-Chu Industrial Park, Hsin-Chu, Taiwan, R. O. C.
- TEL : 886-3-597-7061 FAX : 886-3-597-9220, 597-0785
- China:** (201203) No.255, Jang-Jiang Tsai-Lueng RD. , Pu-Dung-Hsin District, Shang-Hai City, China
- TEL : 86-21-5895-7671 ~ 4 FAX : 86-21-38950165