



# PS300R~PS3010R

## FAST SWITCHING PLASTIC RECTIFIER

**VOLTAGE** 50 to 1000 Volts **CURRENT** 3.0 Amperes

**DO-201AD**

Unit: inch(mm)

### FEATURES

- High current capability.
- Plastic package has Underwriters Laboratory Flammability Classification 94V-O utilizing Flame Retardant Epoxy Molding Compound.
- Low leakage.
- Exceeds environmental standards of MIL-S-19500/228
- Fast switching for high efficiency.
- In compliance with EU RoHS 2002/95/EC directives

### MECHANICAL DATA

- Case: Molded plastic, DO-201AD
- Terminals: Axial leads, solderable to MIL-STD-750, Method 2026
- Polarity: Color Band denotes cathode end
- Mounting Position: Any
- Weight: 0.0395 ounce, 1.122 gram

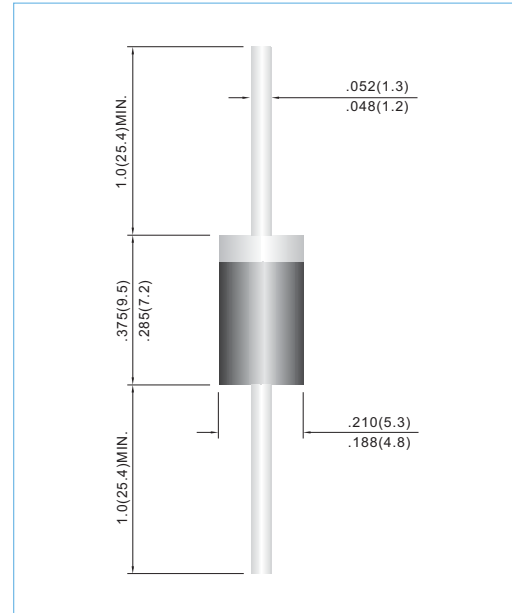

## MAXIMUM RATINGS AND ELECTRICAL CHARACTERISTICS

Ratings at 25°C ambient temperature unless otherwise specified. Resistive or inductive load, 60Hz.

PARAMETER	SYMBOL	PS300R	PS301R	PS302R	PS304R	PS306R	PS308R	PS3010R	UNITS
Maximum Recurrent Peak Reverse Voltage	$V_{RRM}$	50	100	200	400	600	800	1000	V
Maximum RMS Voltage	$V_{RMS}$	35	70	140	280	420	560	700	V
Maximum DC Blocking Voltage	$V_{DC}$	50	100	200	400	600	800	1000	V
Maximum Average Forward Current .375" (9.5mm) lead length at $T_A=55^\circ\text{C}$	$I_{F(AV)}$	3.0							A
Peak Forward Surge Current : 8.3ms single half sine-wave superimposed on rated load(JEDEC method)	$I_{FSM}$	200							A
Maximum Forward Voltage at 3.0A	$V_F$	1.3							V
Maximum DC Reverse Current at $T_j=25^\circ\text{C}$ Rated DC Blocking Voltage $T_j=100^\circ\text{C}$	$I_R$	5.0 500							$\mu\text{A}$
Maximum Reverse Recovery Time (Note 1)	$t_{rr}$	150				250	500		ns
Typical Junction capacitance (Note 2)	$C_J$	60							pF
Typical Thermal Resistance(Note 3)	$R_{\theta JA}$	22							$^\circ\text{C} / \text{W}$
Operating Junction and Storage Temperature Range	$T_J, T_{STG}$	-55 to +150							$^\circ\text{C}$

- NOTES: 1. Reverse Recovery Test Conditions:  $I_F=.5\text{A}$ ,  $I_R=1\text{A}$ ,  $I_{rr}=.25\text{A}$   
 2. Measured at 1 MHz and applied reverse voltage of 4.0 VDC  
 3. Thermal resistance from junction to ambient and from junction to lead length 0.375"(9.5mm) P.C.B. mounted



# PS300R~PS3010R

## RATING AND CHARACTERISTIC CURVES

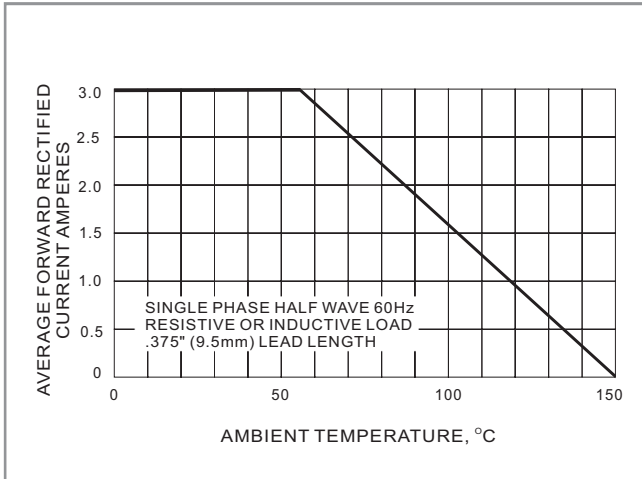

FIG. 1 FORWARD CURRENT DERATING CURVE

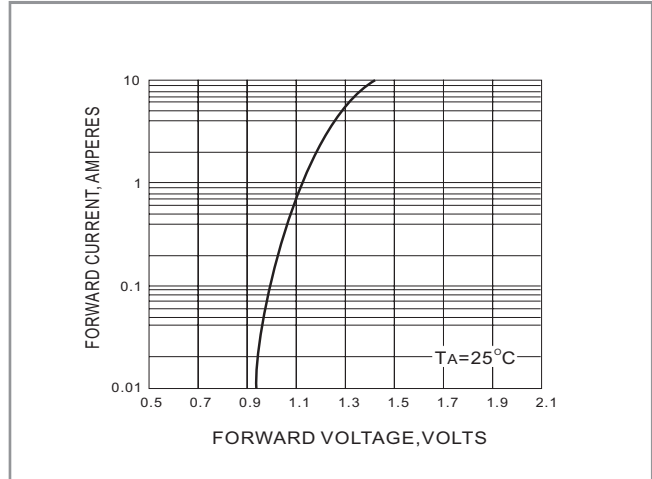

FIG. 2 TYPICAL FORWARD CHARACTERISTIC

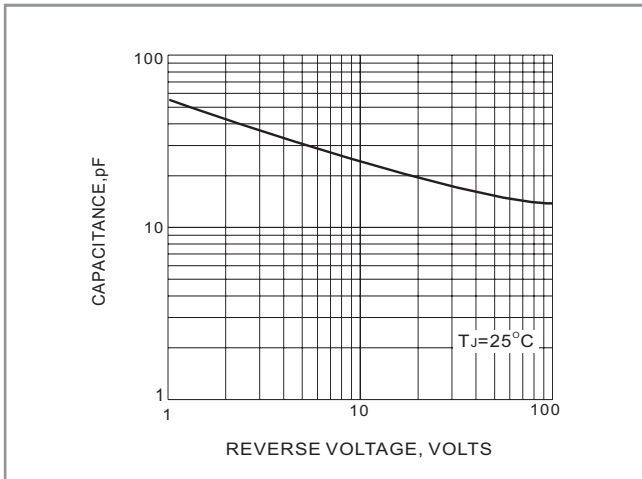

FIG. 3 TYPICAL JUNCTION CAPACITANCE

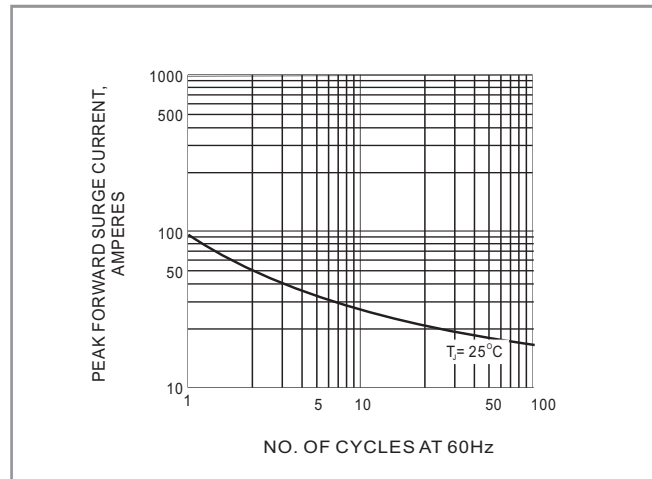

FIG. 4 PEAK FORWARD SURGE CURRENT

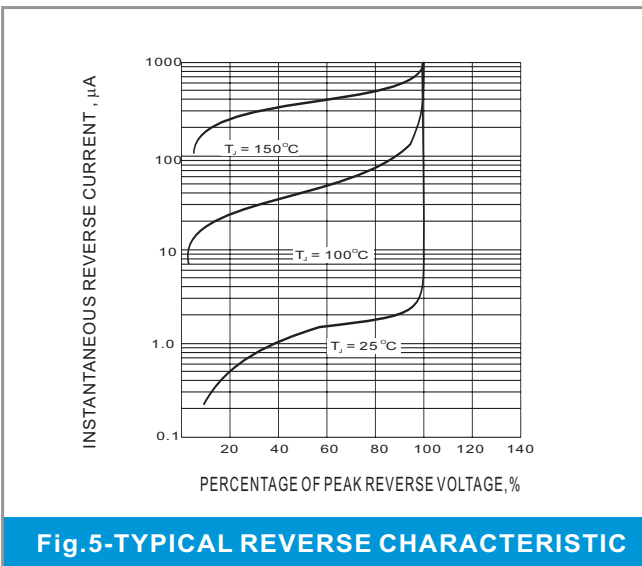

Fig. 5-TYPICAL REVERSE CHARACTERISTIC