HVM14S

Silicon Epitaxial Planar PIN Diode for High Frequency Attenuator

HITACHI

ADE-208-083D(Z)

Rev. 4
Feb. 1999

Features

- Low forward resistance. ($r_f = 7.0\Omega_{\max}$)
- Low capacitance. ($C = 0.25\text{pF typ}$)
- MPAK package is suitable for high density surface mounting and high speed assembly.

Ordering Information

Type No.	Laser Mark	Package Code
HVM14S	H6	MPAK

Outline

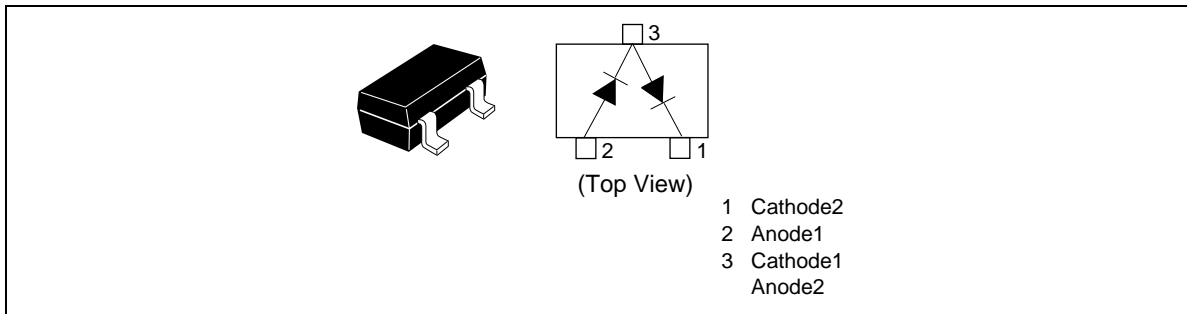

HVM14S

Absolute Maximum Ratings

(Ta = 25°C)

Item	Symbol	Value	Unit
Reverse voltage	V_R	50	V
Forward current	I_F	50	mA
Power dissipation	P_d^{*1}	100	mW
Junction temperature	Tj	125	°C
Storage temperature	Tstg	-55to+125	°C

Note: 1. Two device total.

Electrical Characteristics ^{*2}

(Ta = 25°C)

Item	Symbol	Min	Typ	Max	Unit	Test Condition
Forward voltage	V_F	—	—	1.0	V	$I_F = 50 \text{ mA}$
Reverse current	I_R	—	—	100	nA	$V_R = 50\text{V}$
Capacitance	C	—	0.25	—	pF	$V_R = 50\text{V}, f = 1 \text{ MHz}$
Forward resistance	r_f	—	—	7	Ω	$I_F = 10 \text{ mA}, f = 100 \text{ MHz}$
ESD-Capability ^{*1}	—	200	—	—	V	C=200pF, Both forward and reverse direction 1 pulse

Note: 1. Failure criterion ; $I_R \geq 200\text{nA}$ at $V_R = 50 \text{ V}$

Note: 2. Per one device.

Main Characteristic

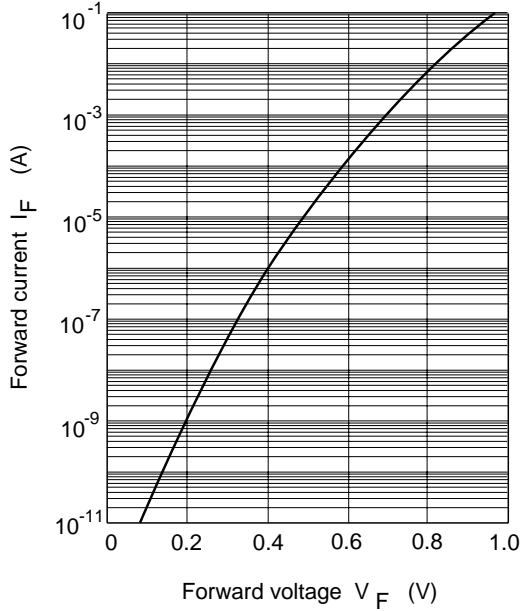

Fig.1 Forward current Vs. Forward voltage

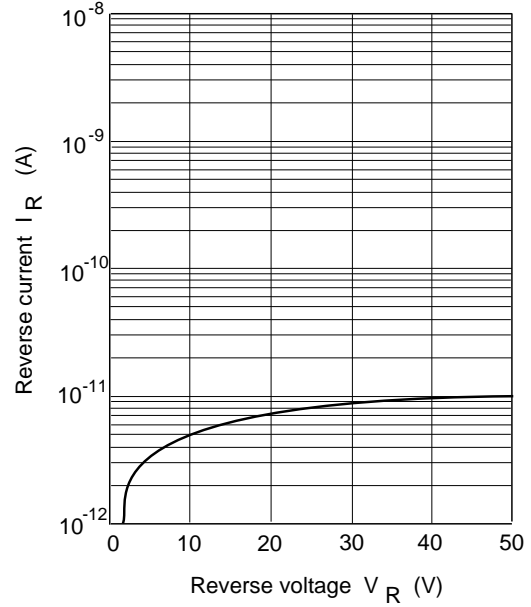

Fig.2 Reverse current Vs. Reverse voltage

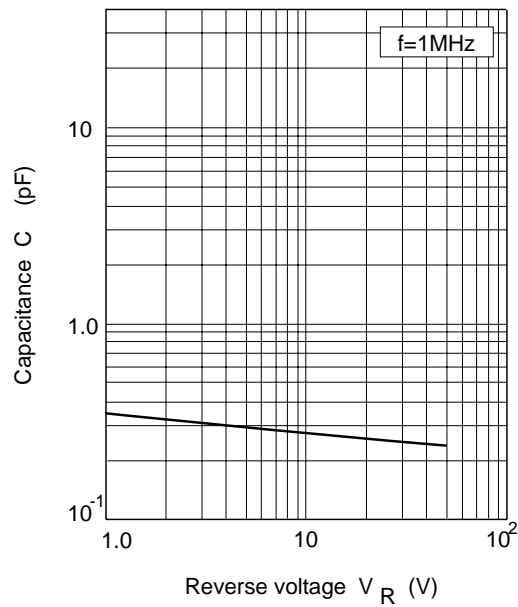

Fig.3 Capacitance Vs. Reverse voltage

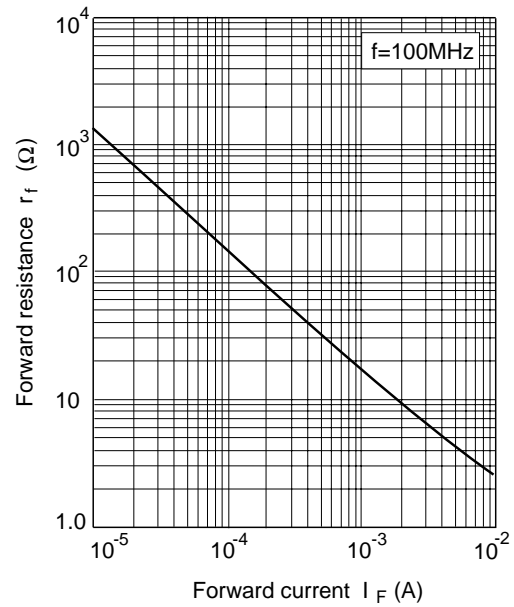
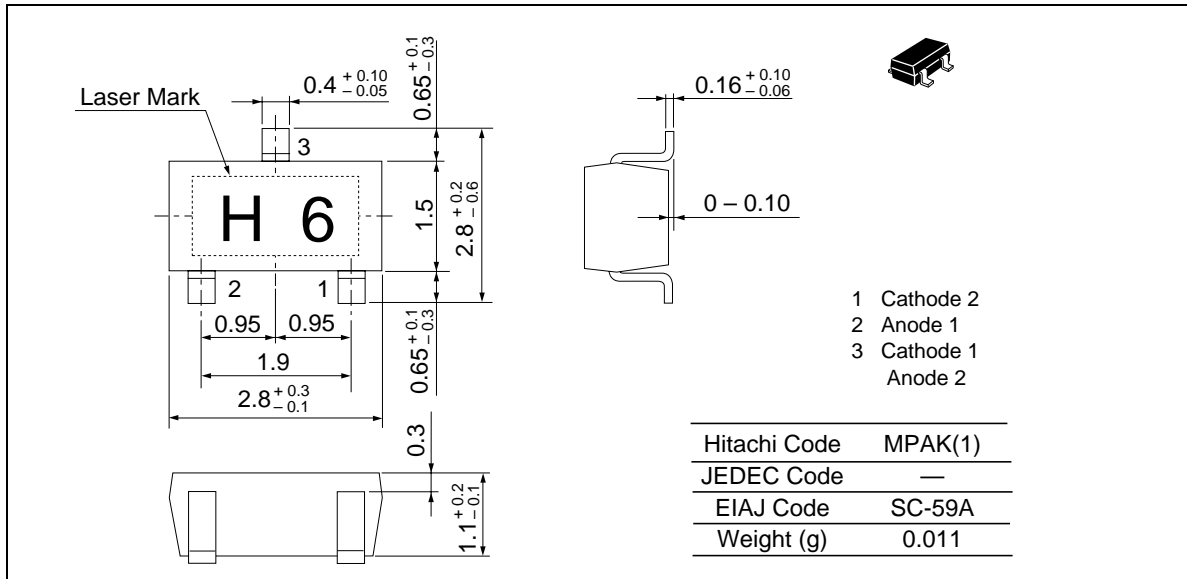

Fig.4 Forward resistance Vs. Forward current

HVM14S

Package Dimensions

Unit : mm



Disclaimer

1. Hitachi neither warrants nor grants licenses of any rights of Hitachi's or any third party's patent, copyright, trademark, or other intellectual property rights for information contained in this document. Hitachi bears no responsibility for problems that may arise with third party's rights, including intellectual property rights, in connection with use of the information contained in this document.
2. Products and product specifications may be subject to change without notice. Confirm that you have received the latest product standards or specifications before final design, purchase or use.
3. Hitachi makes every attempt to ensure that its products are of high quality and reliability. However, contact Hitachi's sales office before using the product in an application that demands especially high quality and reliability or where its failure or malfunction may directly threaten human life or cause risk of bodily injury, such as aerospace, aeronautics, nuclear power, combustion control, transportation, traffic, safety equipment or medical equipment for life support.
4. Design your application so that the product is used within the ranges guaranteed by Hitachi particularly for maximum rating, operating supply voltage range, heat radiation characteristics, installation conditions and other characteristics. Hitachi bears no responsibility for failure or damage when used beyond the guaranteed ranges. Even within the guaranteed ranges, consider normally foreseeable failure rates or failure modes in semiconductor devices and employ systemic measures such as fail-safes, so that the equipment incorporating Hitachi product does not cause bodily injury, fire or other consequential damage due to operation of the Hitachi product.
5. This product is not designed to be radiation resistant.
6. No one is permitted to reproduce or duplicate, in any form, the whole or part of this document without written approval from Hitachi.
7. Contact Hitachi's sales office for any questions regarding this document or Hitachi semiconductor products.

Sales Offices

HITACHI**Hitachi, Ltd.**

Semiconductor & Integrated Circuits
Nippon Bldg., 2-6-2, Ohte-machi, Chiyoda-ku, Tokyo 100-0004, Japan
Tel: (03) 3270-2111 Fax: (03) 3270-5109

URL NorthAmerica : <http://semiconductor.hitachi.com/>
 Europe : <http://www.hitachi-eu.com/hel/ecg>
 Asia : <http://sicapac.hitachi-asia.com>
 Japan : <http://www.hitachi.co.jp/Sicd/indx.htm>

For further information write to:

Hitachi Semiconductor
(America) Inc.
179 East Tasman Drive
San Jose, CA 95134
Tel: <1> (408) 433-1990
Fax: <1> (408) 433-0223

Hitachi Europe Ltd.
Electronic Components Group
Whitebrook Park
Lower Cookham Road
Maidenhead
Berkshire SL6 8YA, United Kingdom
Tel: <44> (1628) 585000
Fax: <44> (1628) 585200

Hitachi Europe GmbH
Electronic Components Group
Dornacher Straße 3
D-85622 Feldkirchen, Munich
Germany
Tel: <49> (89) 9 9180-0
Fax: <49> (89) 9 29 30 00

Hitachi Asia Ltd.
Hitachi Tower
16 Collyer Quay #20-00
Singapore 049318
Tel: <65>-538-6533/538-8577
Fax: <65>-538-6933/538-3877
URL: <http://www.hitachi.com.sg>

Hitachi Asia Ltd.
(Taipei Branch Office)
4/F, No. 167, Tun Hwa North Road
Hung-Kuo Building
Taipei (105), Taiwan
Tel: <886>-(2)-2718-3666
Fax: <886>-(2)-2718-8180
Telex: 23222 HAS-TP
URL: <http://www.hitachi.com.tw>

Hitachi Asia (Hong Kong) Ltd.
Group III (Electronic Components)
7/F., North Tower
World Finance Centre,
Harbour City, Canton Road
Tsim Sha Tsui, Kowloon
Hong Kong
Tel: <852>-(2)-735-9218
Fax: <852>-(2)-730-0281
URL: <http://semiconductor.hitachi.com.hk>

Copyright © Hitachi, Ltd., 2001. All rights reserved. Printed in Japan.
Colophon 4.0