

RoHS Compliant Product
 A suffix of "-C" specifies halogen & lead-free

FEATURES

- Glass passivated chip junction
- High surge overload rating : 30A peak
- Save space on printed circuit boards
- High temperature soldering guaranteed :
 260°C / 10 seconds at 5 lbs. (2.3 kg) tension

MECHANICAL DATA

- Case: Molded plastic body over passivated junctions
- Terminals: Plated leads solderable per MIL-STD-750, Method 2026
- Polarity: Polarity symbols marked on body
 Dimensions in inches and (millimeters)
- Mounting position: Any

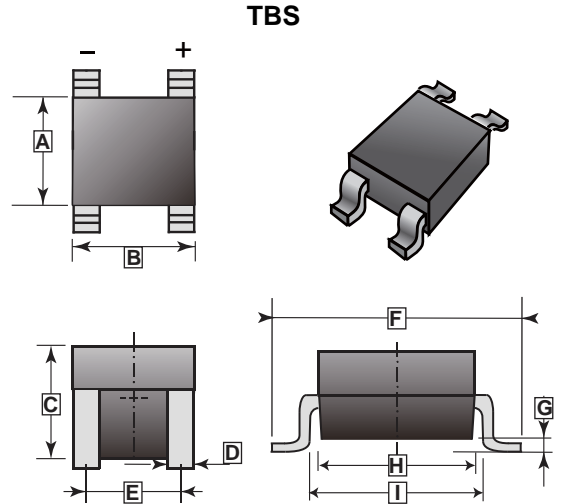

PACKAGE INFORMATION

Package	MPQ	Leader Size
TBS	4K	13 inch

REF.	Millimeter		REF.	Millimeter	
	Min.	Max.		Min.	Max.
A	4.25	4.55	F	6.30	6.70
B	4.85	5.15	G	0.05	0.15
C	1.15	1.45	H	4.25	4.55
D	0.60	0.70	I	0.50	0.70
E	3.90	4.10			

MAXIMUM RATINGS AND ELECTRICAL CHARACTERISTICS

(Rating 25°C ambient temperature unless otherwise specified. Single phase, half wave, 60Hz, resistive or inductive load.
 For capacitive load, derate current by 20%.)

Parameter	Symbol	Part Number					Unit
		TB2S	TB4S	TB6S	TB8S	TB10S	
Maximum Recurrent Reverse Voltage	V_{RRM}	200	400	600	800	1000	V
Maximum RMS Voltage	V_{RMS}	140	280	420	560	700	V
Maximum DC Blocking Voltage	V_{DC}	200	400	600	800	1000	V
Maximum Instantaneous Forward Voltage @ $I_{FM}=0.4A$	V_F	0.95					V
Maximum Average Forward Rectified Current @ $T_L=100^\circ C$	$I_{F(AV)}$	0.8 ¹					A
		1.0 ²					
Peak Forward Surge Current, 8.3ms single half sine-wave superimposed on rated load (JEDEC method)	I_{FSM}	30					A
Typical thermal resistance junction to ambient	On aluminum substrate	62.5					°C / W
	On glass-epoxy substrate	80					
Typical thermal resistance junction to lead	$R_{\theta JL}$	25					
Maximum DC Reverse Current at Rated DC Blocking Voltage @ $T_A=25^\circ C$	I_R	10					A
Operating & Storage Temperature Range	T_J, T_{STG}	-55~150					°C

Notes:

1. On glass epoxy P.C.B.
2. On aluminum substrate.

RATINGS AND CHARACTERISTIC CURVES

FIG.1 TYPICAL FORWARD CHARACTERISTICS

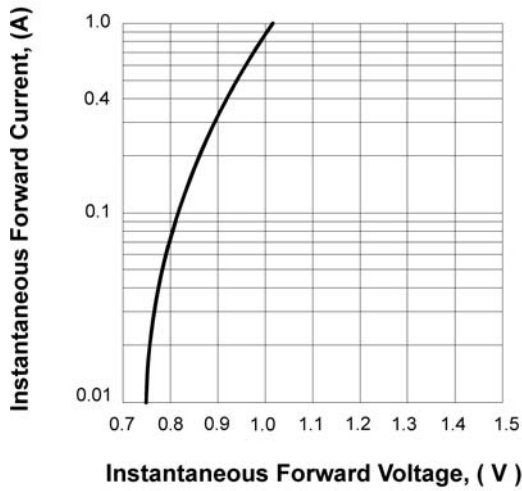

FIG.2 FORWARD DERATING CURVE

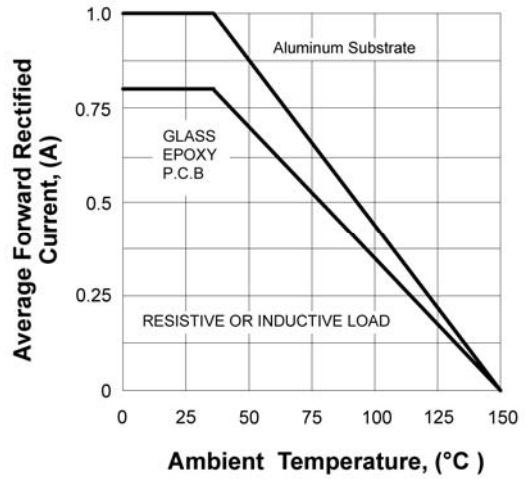

FIG.3 TYPICAL REVERSE CHARACTERISTICS

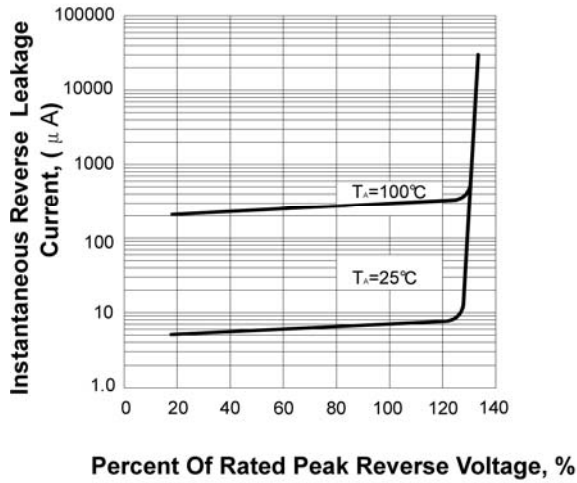

FIG.4 PEAK FORWARD SURGE CURRENT

