

Many applications using a DC/DC regulator are implemented with a resistor divider in the feedback path to set up V_{out} . However, for some high end applications, the voltage needs to be adjusted in order to optimize the application's performance. A Digitally Controlled Potentiometer (DCP) can be used in both high end and low end applications to provide this flexibility.

The typical Buck DC/DC converter scheme includes a PWM driver, switches, inductor, filter, and feedback divider (Figure 1).

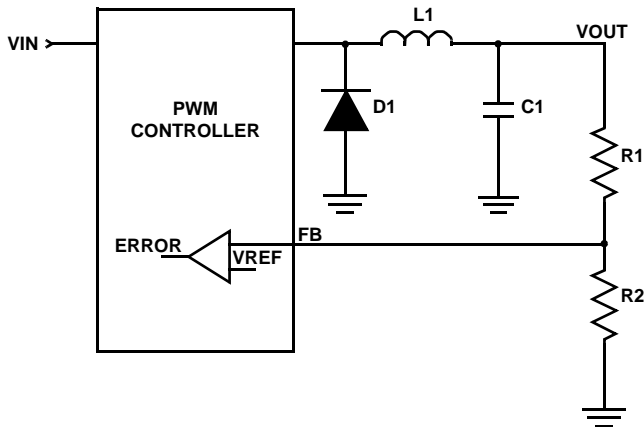

FIGURE 1. TYPICAL BUCK DC/DC CONVERTER

The feedback voltage, FB, from the resistor divider R1 and R2, is a negative input for the error amplifier of the voltage control loop. In addition to the point of load regulation, the feedback divider also sets up the desired output voltage, V_{out} . In other words, V_{out} is programmable through an external resistor divider based on Equation 1.

$$V_{out} = V_{ref} \cdot \left(\frac{R1}{R2} + 1 \right) \quad (EQ. 1)$$

where V_{ref} is a reference voltage and a positive input for the error amplifier.

The minimum output voltage can be set as low as V_{ref} , according to Equation 1. The maximum output is also determined by the resistor divider ratio, as well as input voltage and the maximum duty cycle. The reference voltage, V_{ref} , can be obtained from a PWM controller datasheet.

Thus, making the feedback divider adjustable makes the DC/DC regulator also adjustable, as shown in Figure 2.

The adjustable output voltage of the DC/DC regulator can be expressed by Equation 2.

$$V_{out} = V_{ref} \cdot \left(\frac{R1}{R2 + R_w + R_{total} \cdot \text{code}/(n-1)} + 1 \right) \quad (EQ. 2)$$

where R1 and R2 are fixed resistors, R_w is a wiper resistance, R_{total} is the total resistance of the DCP, code is a decimal code of wiper position and n is a total number of wiper taps.

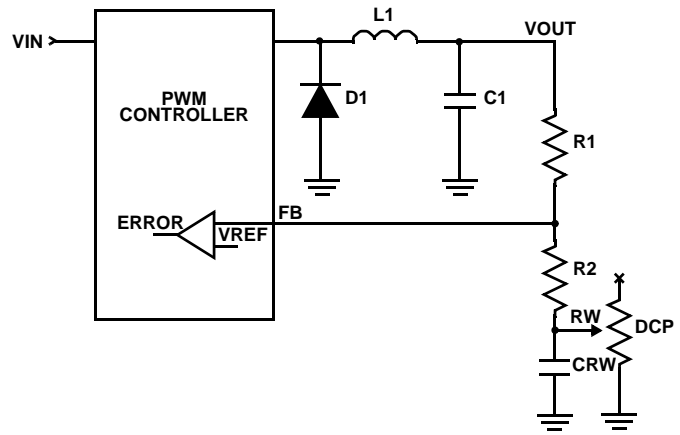

FIGURE 2. ADJUSTABLE POINT OF LOAD DC/DC REGULATOR

The advantages of having the DCP in series with the R2 resistor (rather than in parallel) are easier calculation and bandwidth limitation of the DCP. The DCP terminals have a parasitic capacitance of 10pF to 25pF, which is shown in Figure 2 as C_{rw} . Connecting any of the DCP terminals to the FB node will cause phase shift and may decrease DC/DC regulator performance, such as transient response and stability.

The right DCP should be chosen to meet the application requirements based on knowing the V_{out} adjusting range and desired resolution. For example, we would like to adjust the V_{out} output voltage of a DC/DC regulator, built on the ISL85001 PWM controller, in a range from 0.8V to 3.3V.

The DCP total resistance, R_{total} , R1 and R2 resistor values can be derived from Equation 2. For simplicity, it can be overwritten as Equation 3, where the wiper resistance is counted together with the R2 serial resistor. The suggested value of the R2 resistor should be less than or equal to $0.1 \cdot R_{total}$ in order to have a bigger adjusting range.

$$V_{out} = V_{ref} \cdot \frac{R1 + 0.1R_{total} + R_{total} \cdot \text{code}/(n-1)}{0.1R_{total} + R_{total} \cdot \text{code}/(n-1)} \quad (EQ. 3)$$

The maximum V_{out} will be at code = 0

$$V_{out(max)} = V_{ref} \cdot \frac{R1 + 0.1R_{total}}{0.1R_{total}} \quad (EQ. 4)$$

and the minimum V_{out} will be at max code = n - 1

$$V_{out(min)} = V_{ref} \cdot \frac{R1 + 1.1R_{total}}{1.1R_{total}} \quad (EQ. 5)$$

According to the ISL85001 datasheet, the internal $V_{ref} = 0.6V$ and the recommended value for the R1 resistor is from 1kΩ to 10kΩ. Since the number of R_{total} values of the DCPs are limited, let's select the $R_{total} = 10kΩ$ first and then calculate R1 and R2.

$$R1 = 0.1R_{total} \cdot \frac{V_{out(max)} - V_{ref}}{V_{ref}} = 1kΩ \cdot \frac{3.3V - 0.6V}{0.6V} = 4.5kΩ$$

$$R2 \leq 1kΩ \quad (EQ. 6)$$

Thus, the ideal DCP for this example should have an R_{total} resistance of $10k\Omega$ and minimum wiper resistance.

There are some other features that should be taken into account when choosing the appropriate DCP, such as digital interface, non-volatile programmability, R_{total} tolerance and Temperature Coefficient (TCr). Most of the available DCPs on the market have a $\pm 20\%$ R_{total} tolerance from part to part. That means each DC/DC regulator requires calibration and that the calibrated value of the wiper position can be stored in the non-volatile memory.

The perfect solution for DC/DC margining uses a 1% precision DCP, like the ISL22317, which eliminates the necessity of individual calibration and provides 0Ω of wiper resistance and low TCr. The V_{out} curve versus ISL22317W tap position is shown in Figure 3. Since Equation 2 is a hyperbola, the V_{out} resolution per step changes with the tap position, from 50mV per tap at the low end to 2mV per tap at the high end of the DCP settings in our example.

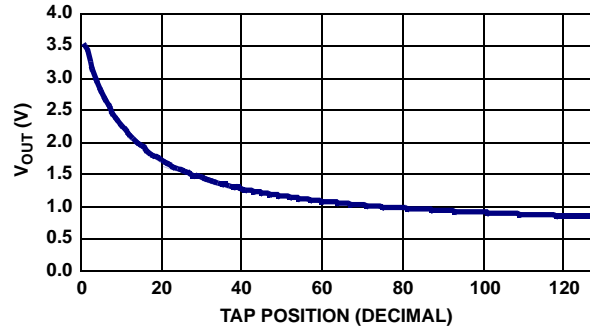

FIGURE 3. THE ISL85001 V_{OUT} vs THE ISL22317W TAP POSITION