

IS31AP2010E

MONO FILTER-LESS CLASS-D AUDIO POWER AMPLIFIER

Advanced Information

May 2012

GENERAL DESCRIPTION

The IS31AP2010E is a high efficiency, mono filter-less class-D audio power amplifier. A low noise, filter-less PWM architecture eliminates the output filter, reduces external component count, system cost, and simplifying design.

In cellular handsets, the earpiece, speaker phone, and melody ringer speaker can each be driven by the IS31AP2010E. The gain of IS31AP2010E is externally configurable which allows independent gain control from multiple sources by summing signals from each function.

IS31AP2010E is available in UTQFN-9 packages. It operates from 2.7V to 5.5V over the temperature range of -40°C to +85°C.

FEATURES

- Supply voltage from 2.7V ~ 5.5V
- High efficiency
- Less than 1μA shutdown current
- Optimized PWM output stage eliminates LC output filter
- Fully differential design reduces RF rectification and eliminates bypass capacitor
- Improved CMRR eliminates two input coupling capacitors
- Integrated click-and-pop suppression circuitry
- UTQFN-9 package
- RoHS compliant and 100% lead(Pb)-free

APPLICATIONS

- Wireless or cellular handsets and PDAs
- Portable DVD player
- Notebook PC
- Portable radio
- Educational toys
- Portable gaming

TYPICAL APPLICATION CIRCUIT

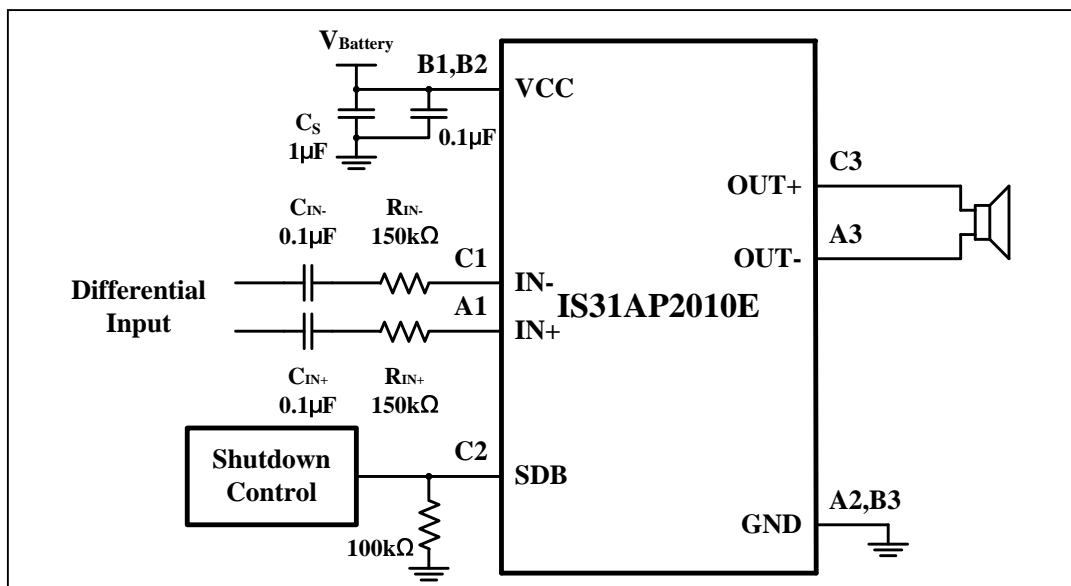

Figure 1 Typical Application Circuit (Differential Input)

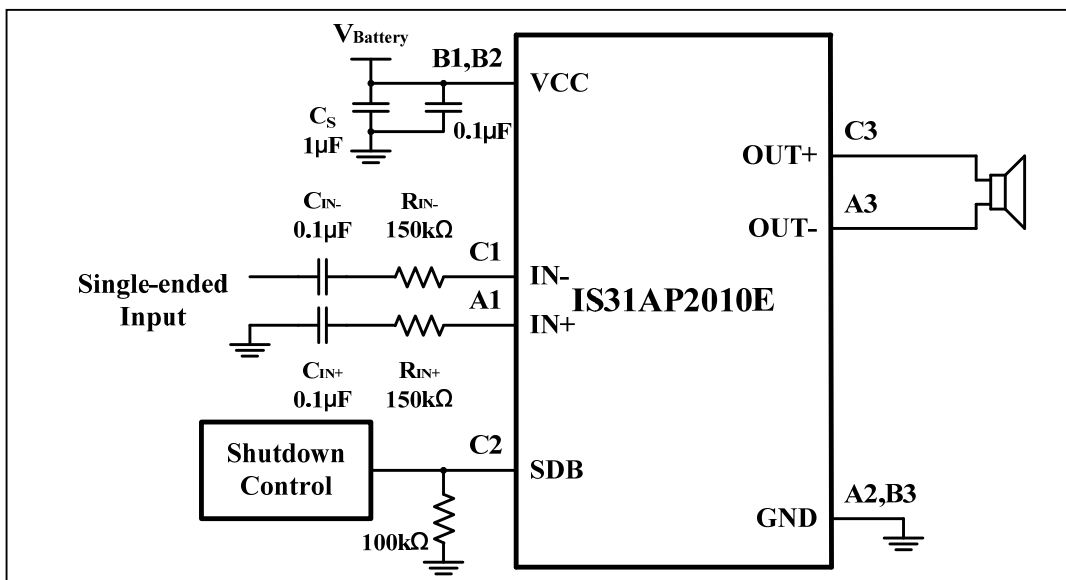
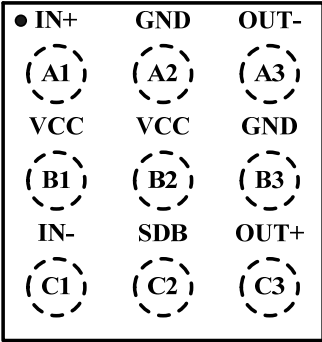

Figure 2 Typical Application Circuit (Single-ended Input)

IS31AP2010E

PIN CONFIGURATION

Package	Pin Configuration (Top View)
UTQFN-9	 <p> • IN+ GND OUT- (A1) (A2) (A3) VCC VCC GND (B1) (B2) (B3) IN- SDB OUT+ (C1) (C2) (C3) </p>

PIN DESCRIPTION

No.	Pin	Description
A1	IN+	Positive audio input.
A2, B3	GND	Connect to ground.
A3	OUT-	Negative audio output.
B1, B2	VCC	Power supply.
C1	IN-	Negative audio input.
C2	SDB	Enter in shutdown mode when active low.
C3	OUT+	Positive audio output.

Copyright © 2011 Integrated Silicon Solution, Inc. All rights reserved. ISSI reserves the right to make changes to this specification and its products at any time without notice. ISSI assumes no liability arising out of the application or use of any information, products or services described herein. Customers are advised to obtain the latest version of this device specification before relying on any published information and before placing orders for products.

Integrated Silicon Solution, Inc. does not recommend the use of any of its products in life support applications where the failure or malfunction of the product can reasonably be expected to cause failure of the life support system or to significantly affect its safety or effectiveness. Products are not authorized for use in such applications unless Integrated Silicon Solution, Inc. receives written assurance to its satisfaction, that:

- a.) the risk of injury or damage has been minimized;
- b.) the user assume all such risks; and
- c.) potential liability of Integrated Silicon Solution, Inc is adequately protected under the circumstances



IS31AP2010E

ORDERING INFORMATION

Industrial Range: -40°C to +85°C

Order Part No.	Package	QTY/Reel
IS31AP2010E-UTLS2-TR	UTQFN-9, Lead-free	3000



IS31AP2010E

ABSOLUTE MAXIMUM RATINGS

Supply voltage, V_{CC}	-0.3V ~ +6.0V
Voltage at any input pin	-0.3V ~ $V_{CC}+0.3V$
Junction temperature, T_{JMAX}	+150°C
Storage temperature range, T_{stg}	-65°C ~ +150°C

Note:

1. Stresses beyond those listed under “Absolute Maximum Ratings” may cause permanent damage to the device. These are stress ratings only and functional operation of the device at these or any other condition beyond those indicated in the operational sections of the specifications is not implied. Exposure to absolute maximum rating conditions for extended periods may affect device reliability.

ELECTRICAL CHARACTERISTICS

$V_{CC} = 2.7V \sim 5.5V$, $T_A = 25^\circ C$, unless otherwise noted. (Note 1)

Symbol	Parameter	Condition	Min.	Typ.	Max.	Unit
V_{CC}	Supply voltage		2.7		5.5	V
$ V_{OS} $	Output offset voltage (measured differentially)	$V_{SDB} = 0V$, $A_V = 2V/V$		10		mV
I_{CC}	Quiescent current	$V_{CC} = 5.5V$, no load		2.6		mA
		$V_{CC} = 2.7V$, no load		1.2		
I_{SD}	Shutdown current	$V_{SDB} = 0.4V$			1	μA
f_{sw}	Switching frequency			250		kHz
R_{IN}	Input resistor	Gain $\leq 20V/V$	15			k Ω
Gain		$R_{IN} = 150k\Omega$		2		V/V
V_{IH}	High-level input voltage		1.4		V_{CC}	V
V_{IL}	Low-level input voltage		0		0.4	V

IS31AP2010E

ELECTRICAL CHARACTERISTICS

$T_A = 25^\circ\text{C}$, Gain = 2V/V, $C_{IN} = 2\mu\text{F}$, unless otherwise noted. (Note 2)

Symbol	Parameter	Condition	Min.	Typ.	Max.	Unit
P_O	Output power	THD+N = 10% $f = 1\text{kHz}$, $R_L = 8\Omega$	$V_{CC} = 5.0\text{V}$		1.68	W
			$V_{CC} = 4.2\text{V}$		1.2	
			$V_{CC} = 3.6\text{V}$		0.88	
		THD+N = 10% $f = 1\text{kHz}$, $R_L = 4\Omega$	$V_{CC} = 5.0\text{V}$		3.0	W
			$V_{CC} = 4.2\text{V}$		2.0	
			$V_{CC} = 3.6\text{V}$		1.5	
		THD+N = 1% $f = 1\text{kHz}$, $R_L = 8\Omega$	$V_{CC} = 5.0\text{V}$		1.4	W
			$V_{CC} = 4.2\text{V}$		1.0	
			$V_{CC} = 3.6\text{V}$		0.7	
		THD+N = 1% $f = 1\text{kHz}$, $R_L = 4\Omega$	$V_{CC} = 5.0\text{V}$		2.4	W
			$V_{CC} = 4.2\text{V}$		1.68	
			$V_{CC} = 3.6\text{V}$		1.2	
THD+N	Total harmonic distortion plus noise	$V_{CC} = 4.2\text{V}$, $P_O = 0.6\text{W}$, $R_L = 8\Omega$, $f = 1\text{kHz}$		0.18	%	
		$V_{CC} = 4.2\text{V}$, $P_O = 1.1\text{W}$, $R_L = 4\Omega$, $f = 1\text{kHz}$		0.22		
V_{NO}	Output voltage noise	$V_{CC} = 4.2\text{V}$, $f = 20\text{Hz}$ to 20kHz Inputs AC-grounded		80	μVrms	
T_{WU}	Wake-up time from shutdown	$V_{CC} = 3.6\text{V}$		32	ms	
SNR	Signal-to-noise ratio	$P_O = 1.0\text{W}$, $R_L = 8\Omega$, $V_{CC} = 4.2\text{V}$		91	dB	
PSRR	Power supply rejection ratio	$f = 217\text{Hz}$, $R_L = 8\Omega$ Input grounded	$V_{CC} = 5.0\text{V}$		-75	dB
			$V_{CC} = 4.2\text{V}$		-70	
			$V_{CC} = 3.6\text{V}$		-66	

Note 1: All parts are production tested at $T_A = 25^\circ\text{C}$. Other temperature limits are guaranteed by design.

Note 2: Guaranteed by design.

IS31AP2010E

PACKAGING INFORMATION

UTQFN-9

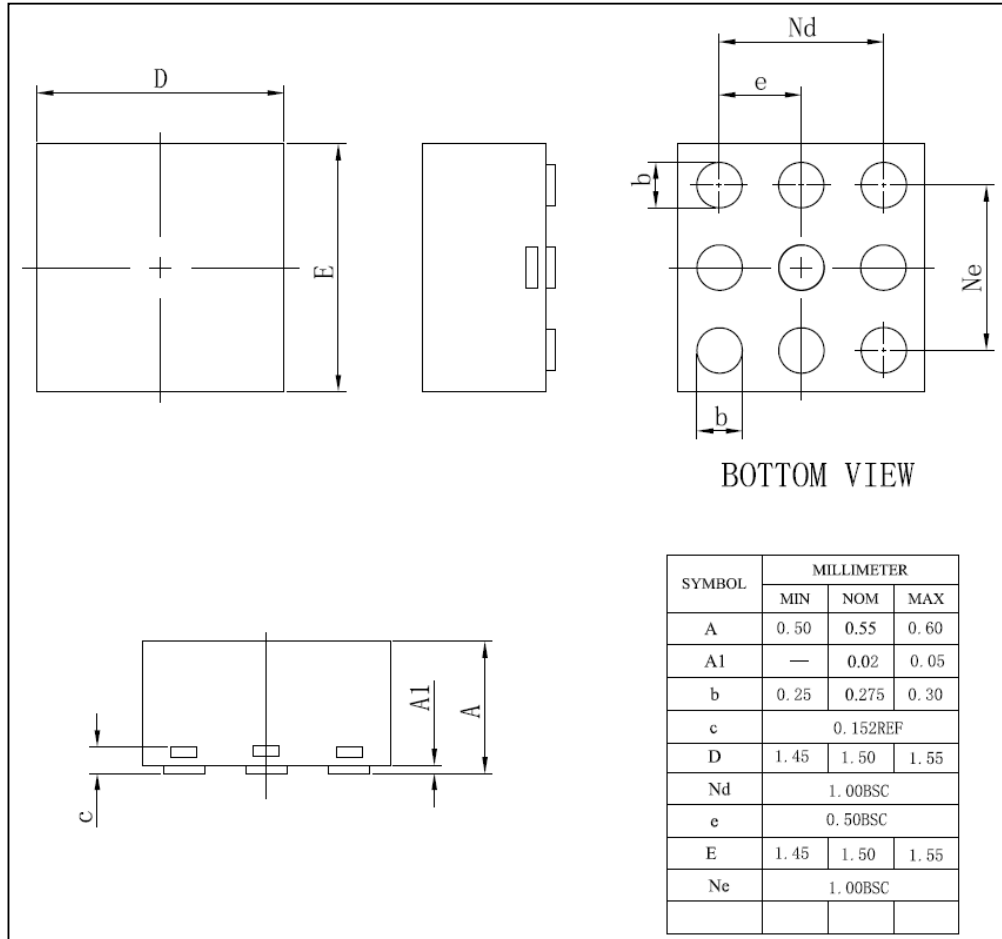

Note: All dimensions in millimeters unless otherwise stated.