

# KMA200

## Programmable angle sensor

Rev. 8 — 7 December 2011

Product data sheet

## 1. Product profile

### 1.1 General description

The KMA200 is an angle sensor system. The MagnetoResistive (MR) element and the mixed signal Integrated Circuit (IC) are integrated in one package. This angle system is already pre-programmed, offsets are compensated and therefore, ready to use.

Via the Serial Peripheral Interface (SPI) the KMA200 is user programmable. This allows user specific adjustments of the maximum angle, zero point, clamping level and a 32-bit identifier. The data is stored permanently in an Electrically Erasable Programmable Read-Only Memory (EEPROM).

The device can be programmed to work either in analog or digital (SPI) output mode. Furthermore, different analog output characteristics are possible. The resolution is better than 0.05°.

The implemented online diagnosis supervises the input and output signals as well as the data processing. Deviations and failures of the angle value are indicated in the output signal. Overall temperature supervision is implemented.

### 1.2 Features and benefits

- Magnetic field angular sensing
- High accuracy
- Operating temperature range from -40 °C to +160 °C
- Online diagnosis
- Bidirectional digital interface (SPI)
- Programmable maximum angle up to 180°
- Pre-calibrated, ready to use device
- One package angle sensor system
- Resolution better than 0.05°
- Digital or analog output signals (user programmable)
- Overvoltage protection at all external pins
- EEPROM (user programmable)
- Programmable zero point



### 1.3 Quick reference data

Table 1. Quick reference data

Symbol	Parameter	Conditions	Min	Typ	Max	Unit
V <sub>DD</sub>	supply voltage	normal operation	4.5	5.0	5.5	V
V <sub>DD(pr)</sub>	programming supply voltage	EEPROM	12	12.5	13	V
T <sub>amb</sub>	ambient temperature	< 1000 hours in life time at 160 °C	-40	-	+160	°C
T <sub>amb(pr)</sub>	programming ambient temperature	EEPROM	10	-	70	°C
C <sub>L</sub>	load capacitance	at pin 2 and pin 3	0.1	-	27	nF
R <sub>L(pu)</sub>	pull-up load resistance		[1] 5	-	∞	kΩ
R <sub>L(pd)</sub>	pull-down load resistance		[2][3] 5	-	10	kΩ
C <sub>ext</sub>	external capacitance between V <sub>DD</sub> and GND	conducted closely to supply pins of KMA200	82	-	120	nF

- [1] Diagnosis GND and V<sub>DD</sub> lost only possible with a pull-up resistor of 5 kΩ to 6 kΩ.
- [2] Diagnosis V<sub>DD</sub> lost only possible with a pull-down resistor of 5 kΩ to 6 kΩ.
- [3] Load resistor required to enable the diagnosis features. Infinite resistor load permitted for normal operation without the diagnosis features.

## 2. Pinning information

Table 2. Pinning

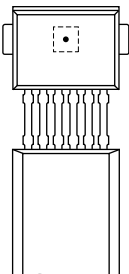
Pin	Symbol	Description	Simplified outline <sup>[1]</sup>
1	V <sub>DD</sub>	supply voltage	
2	DATA/OUT1	data Input/Output (I/O) analog output 1	
3	CLK/OUT2	data clock analog output 2	
4	GND	ground	
5	$\overline{CS}$	chip select (used for data transfer I/O)	

- [1] The other pins and lead frame parts must not be electrical connected. For operation of the device the external pins must/have to be used.

## 3. Ordering information

Table 3. Ordering information

Type number	Package		Version
	Name	Description	
KMA200	-	plastic single-ended multi-chip package; 6 interconnections; 5 in-line leads	SOT637

4. Functional diagram

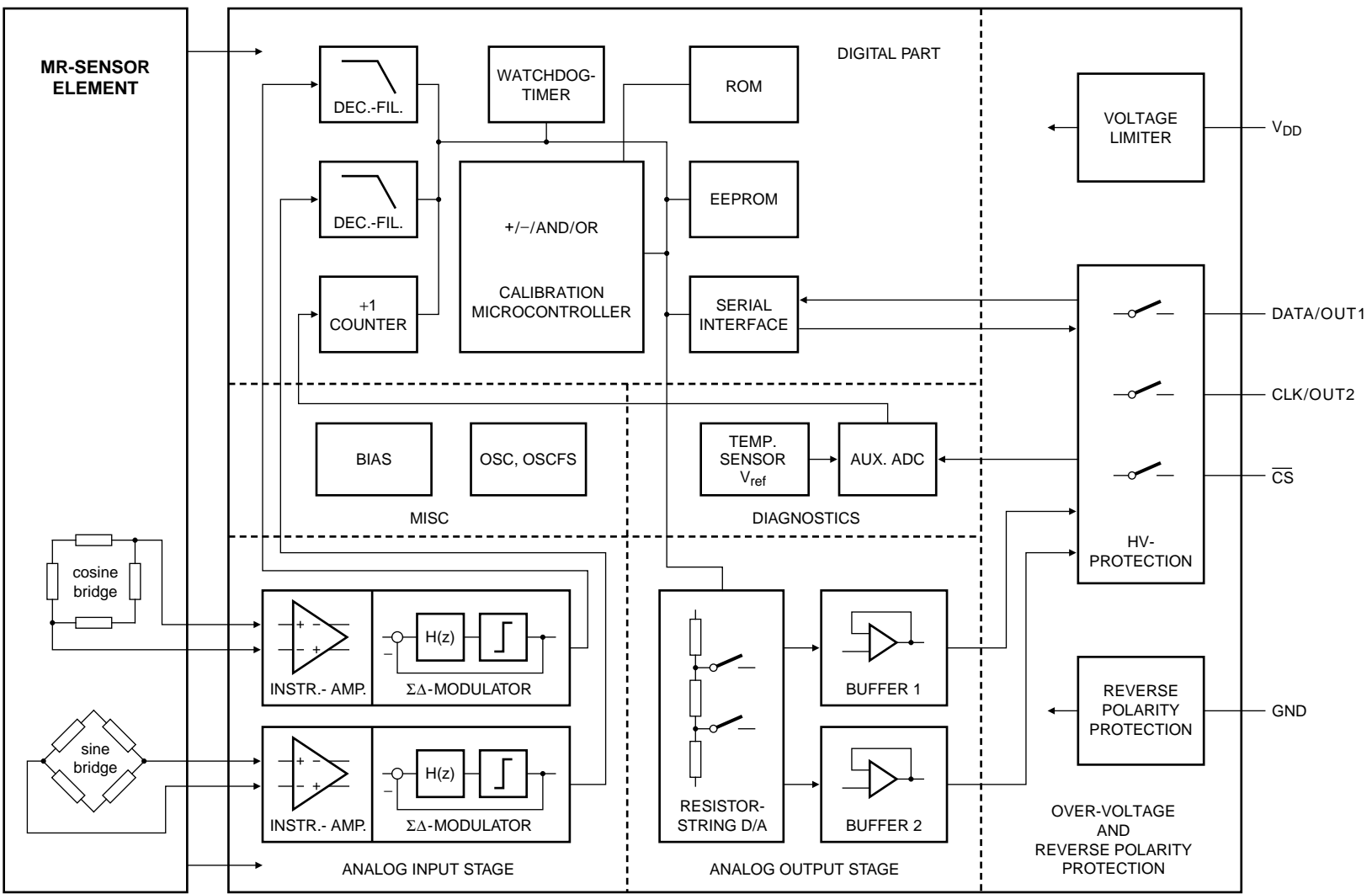

006aaa296

Fig 1. Functional diagram

## 5. Functional description

The KMA200 amplifies two orthogonal sinusoidal signals delivered by the MR-sensor element and converts them into the digital domain. Using the COordinate Rotation Digital Computer (CORDIC) algorithm, the angle is calculated. Angle output is either analog or digital. The KMA200 comprises diagnostic features that ensure a complete online supervision of all essential functional blocks including verification of input and output signals and temperature supervision. In addition, the circuit is protected against reverse polarity, overvoltage and short circuit at all external pins.

Two instrumentation amplifiers and  $\Sigma\Delta$ -modulators convert the amplified signals into two high-speed digital bit streams. The bit streams are filtered and decimated by two digital decimation filters to obtain digital signals with higher resolution at a lower speed.

Further processing is done within an on-chip calibration microcontroller. This includes offset cancellation, calculation of the mechanical angle using the CORDIC algorithm, zero-angle and angular-range adjustment.

In addition, the calibration microcontroller performs diagnostic tasks to ensure the validity of its results. The calibration microcontroller takes calibration constants from an on-chip EEPROM and stores intermediate results in a Random Access Memory (RAM). The calculated angle is given out either digitally with an SPI-compatible serial interface or analog via the analog output stage. Several output characteristics can be selected.

In case of analog output the analog output stage is used for conversion of the angle information into two analog output voltages ratiometric to the supply voltages. For this purpose, the analog output stage contains two resistor-string Digital-to-Analog Converters (DACs) which share the same resistor string. The two analog output voltages are buffered by two offset-compensated amplifiers.

The internal circuitry is protected against overvoltage with special protection circuits. Protection against reverse polarity is realized with the help of a current limiting circuit.

In addition, there are various support circuits like bias generators, a free-running oscillator including an oscillator fail-safe circuit and a power-on reset circuit which generates a reset in dependence of the supply voltage.

## 6. Diagnostic features

The KMA200 includes diagnostic features to ensure the validity of its output signals. The diagnostic features can be configured with the control information words (ctrl) written to the user-programmable EEPROM.

In the analog output modes a diagnostic error condition is signaled to the user by setting the outputs into the high-impedance state. The outputs are forced to lie in the upper or lower diagnostic range by external pull-up or pull-down resistors.

With no external pull-up/pull-down resistors the output signal will be internally pulled up to upper diagnosis range.

If digital output is selected, an error condition can also be signaled by setting the error flag in the digital output word. The least significant bits show the error code. The [Table 4](#) shows the behavior in detail:

Once a diagnostic error condition is reached, the KMA200 continues to work normally after a new external power-on reset or by itself, as described in the table below. It is possible to configure the KMA200 the way that the error condition has to be fulfilled more than once. The number of error conditions that is necessary can also be programmed with bits in the control information words.

**Table 4. Summary KMA200 behavior at diagnosis conditions in normal operation mode**

Error appearance	Analog output	Digital output
Oscillator fail detection	[1] high-impedance state	[1] high-impedance state
Cyclic Redundancy Check (CRC)	[1] high-impedance state	[1] diagnosis bit set
Watchdog	[1] high-impedance state	[1] high-impedance state
Input stage (including magnet lost)	high-impedance state	diagnosis bit set
Output stage	[1] high-impedance state	-
Over-temperature warning	-	diagnosis bit set
Over-temperature shutdown	[1] high-impedance state	[1] high-impedance state
Overvoltage	high-impedance state	high-impedance state
Reverse polarity	high-impedance state	high-impedance state

[1] Reactivation for angular measurement with valid angle information (normal operation mode) only by new external power-on reset

### Temperature supervision

The chip temperature measured within the KMA200 can be used to detect over-temperature conditions. Two temperature levels are defined: the temperature warning level and the temperature shutdown level.

The user can evaluate the temperature warning if digital output mode is selected. When the device temperature exceeds the warning level, the error flag in the digital output word is set. The other data bits still show the angle information. In the analog output modes, the device temperature warning is not available. If the temperature exceeds the over-temperature shutdown level, the KMA200 switches off.

### Diagnosis of input stage

For diagnosis of the input stage, the calibration microcontroller calculates the expected signal magnitude using the temperature information and the EEPROM constants and compares it to the signal magnitude based on the current measurement.

If the difference of the two magnitudes is greater than an allowed deviation, an error condition is signaled to the user.

The allowed difference depends on the bits DI1 and DI0 in the EEPROM control information word.

### Diagnosis of output stage

Both analog outputs are supervised by the auxiliary ADC which reads the present analog signal and converts it back to the digital domain with a resolution of 8 bits. The digitized value is compared to the digital angle value originally sent.

If the difference of these two values is greater than an error bound, an error condition is signaled by switching off the analog outputs.

The allowed difference depends on the bits DO1 and DO0 in the EEPROM control information word.

### CRC check of EEPROM constants

During normal operation mode a CRC code of the configuration constants taken from the EEPROM is calculated on a regular basis. This code is compared to a pre-calculated CRC code from the EEPROM (CRC). If there is a mismatch, an error condition is signaled to the user by setting the error flag in the digital output word or by switching off the analog outputs.

The CRC code used is the CRC-16 code (*ISO/IEC 3309:1993* and *ITU-T V.42*)

### Watchdog timer

The KMA200 comprises a watchdog timer to supervise the flow of the program. After reset, the watchdog is automatically activated. During operation the watchdog timer must be toggled on a regular basis, as otherwise the error condition is signaled. The access to the watchdog timer is protected against unwanted operations using a fail-safe watchdog feed sequence.

**Oscillator fail-safe circuit**

The function of the free-running oscillator is checked with re-triggered mono flop. If the mono flop is not triggered, the KMA200 signals an error.

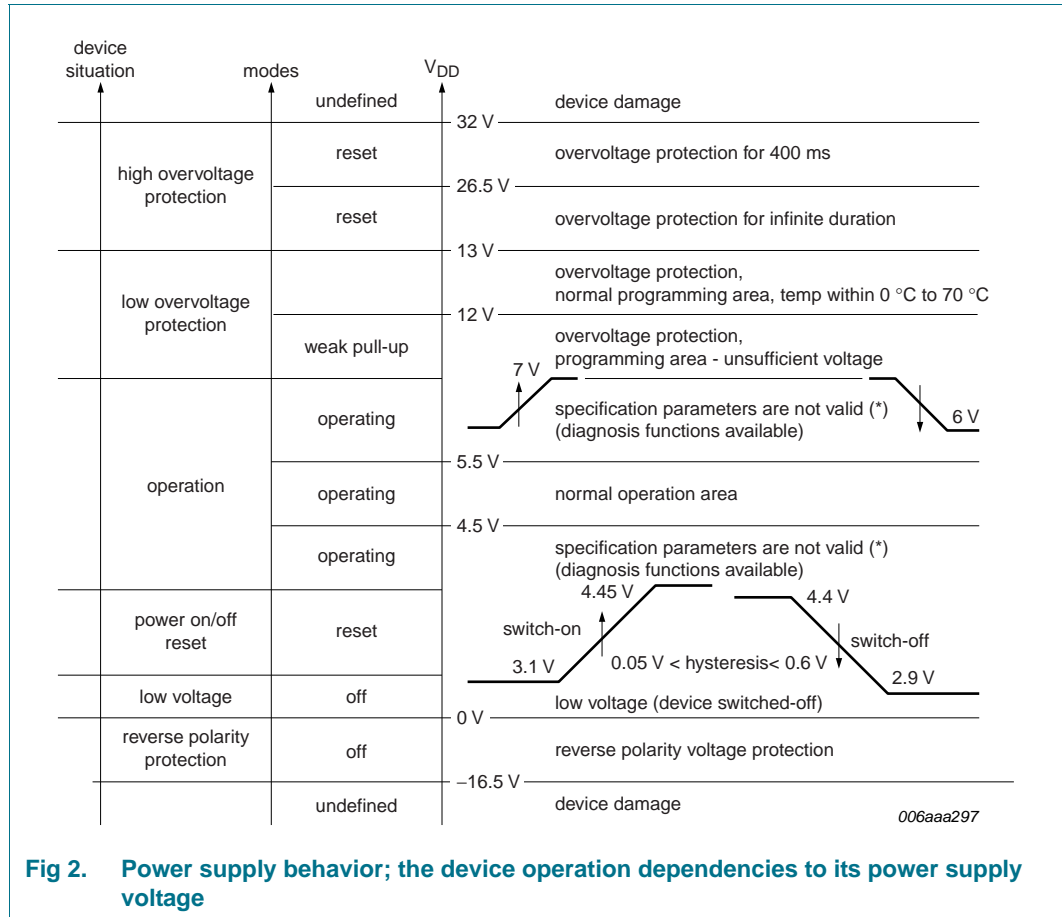

**Fig 2. Power supply behavior; the device operation dependencies to its power supply voltage**

## 7. Outputs of KMA200

The output of the KMA200 is either digital or analog, depending on the control word stored in the EEPROM. The analog output consists of a standard and a programmable output stage. The programmable output stage allows four different characteristics; mode 1, mode 2, mode 3 or none output. The digital output has two different modes; mode 5 and mode 6.

### Analog output

In the analog output mode the measured angle value is converted linear into a value that is ratiometric to the supply voltage  $V_{DD}$ . This voltage is driven by the standard output stage to pin DATA/OUT1. The same value is fed to a second output stage that is connected to pin CLK/OUT2. This second output stage is programmable to one of four different output characteristics; mode 1, mode 2, mode 3 or high-impedance state output.

A valid angle value is nominally mapped to an output voltage range of  $V_{(CL)l}$  (default = 5 %) to  $V_{(CL)u}$  (default = 95 %) of  $V_{DD}$  at the standard output  $V_{OUT1}$  (see [Figure 3](#)).

For mode 1 the valid output voltage range at pin CLK/OUT2 is identical to the output voltage range of the standard analog voltage but the output characteristic is inverted (see [Figure 4](#)).

In mode 2 (see [Figure 5](#)) the valid output range at pin CLK/OUT2 is nominally  $V_{(CL)l}/2$  to  $V_{(CL)u}/2$  of  $V_{DD}$ .

A further possibility is to program the  $V_{OUT2}$  (mode 3,  $\alpha_{thresh}$ ) as a comparator depending from the angle value (see [Figure 6](#)).

When the KMA200 detects an error condition, it switches the analog outputs into high-impedance state. The outputs are forced to lie in the upper or lower diagnostic range by the external pull-up or pull-down resistors.

**Table 5. Setting the KMA200 output characteristics**

Output characteristics		Pin assignment		Mode setting of EEPROM (ctrl1)		
Mode	Type	DATA/OUT1	CLK/OUT2	OM2	OM1	OM0
Mode 1	analog	standard	inverted	1	0	0
Mode 2	analog	standard	half range	1	0	1
Mode 3	analog	standard	comparator	1	1	0
Mode 4	analog	standard	high-impedance state	1	1	1
Mode 5	digital	serial data (SPI)	(clock)	0	0	0
Mode 6	digital	bit complement serial data (SPI)	(clock)	0	0	1



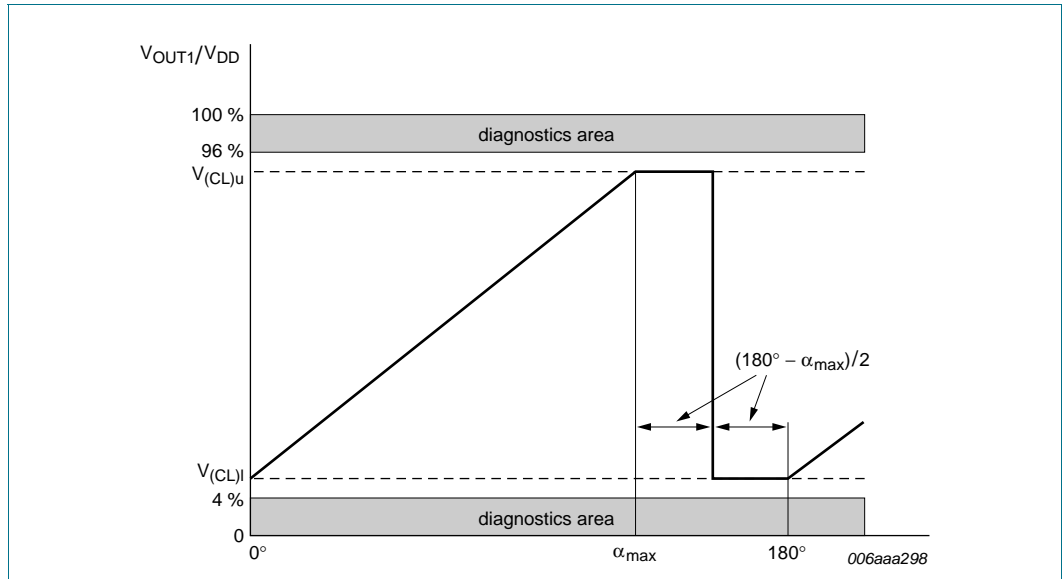

Fig 3. Standard analog output mode

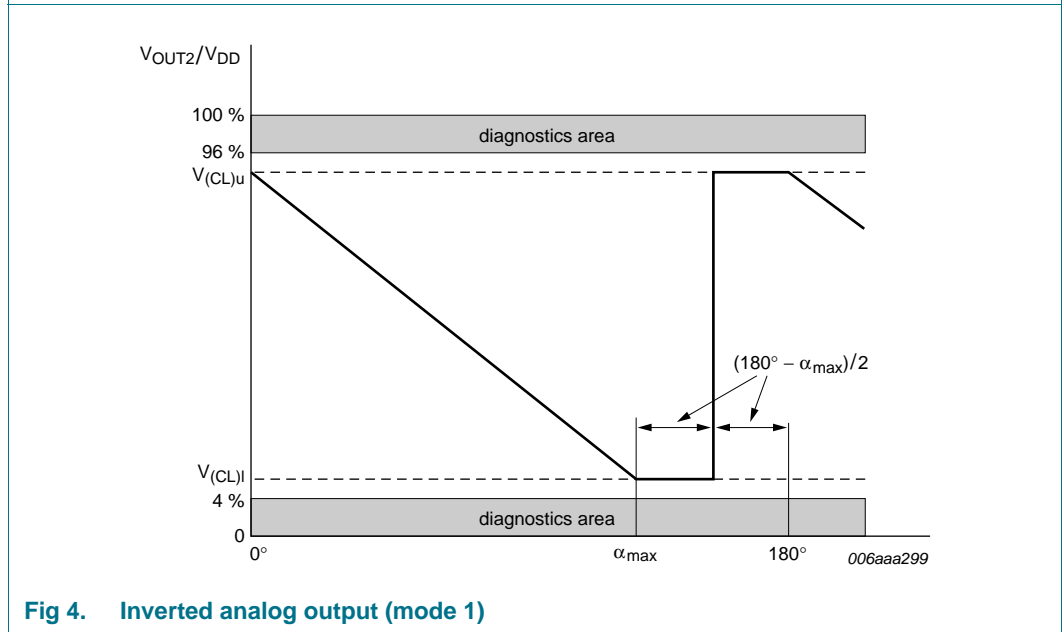

Fig 4. Inverted analog output (mode 1)

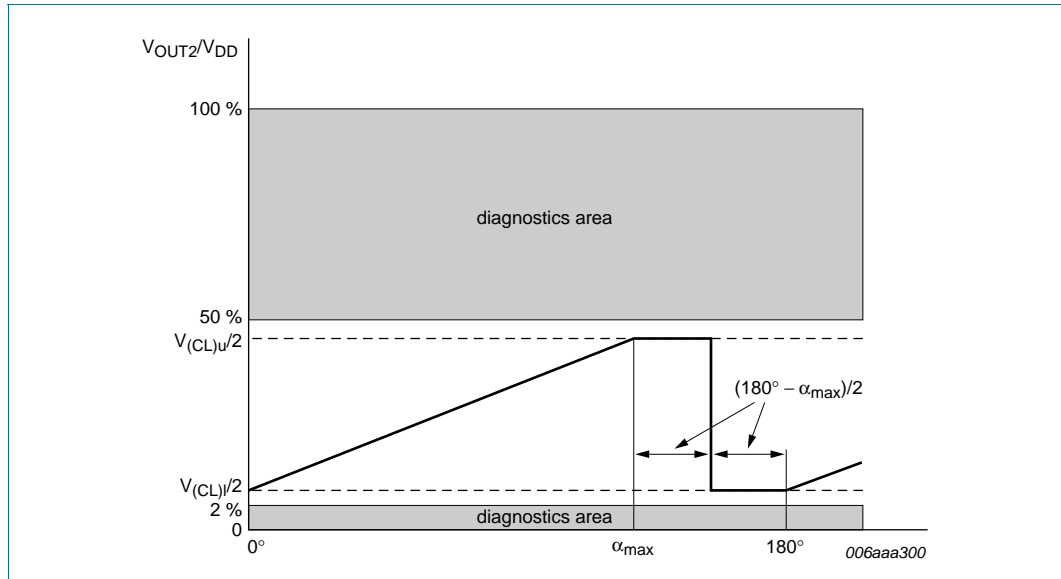

Fig 5. Half range output mode (mode 2)

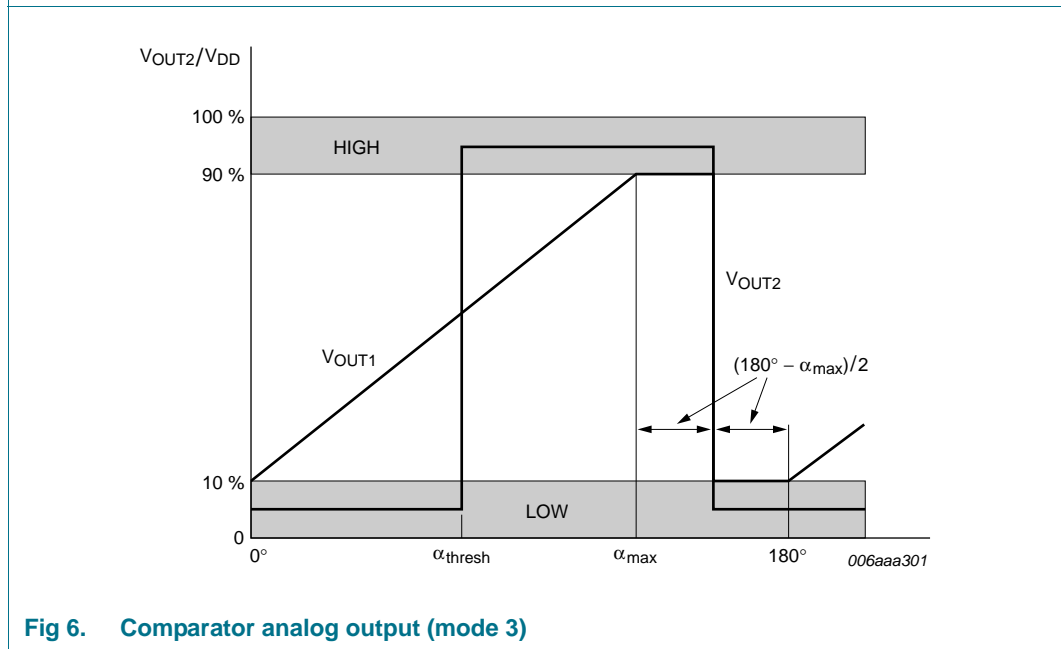

Fig 6. Comparator analog output (mode 3)

## 8. Digital output (SPI)

### Standard digital output

If the standard digital output mode is configured, output data can be read with the serial interface. [Figure 7](#) shows the timing diagram of an interface access. The access is enclosed by a HIGH-to-LOW and LOW-to-HIGH transition of  $\overline{CS}$ .

DATA are clocked out at the falling edge of CLK and should be evaluated at the rising edge. The output data consist of 3 bytes (24 bits). The first two data bytes contain an error flag and 13 bits of angle information. The last data byte contains the measured temperature as 7-bit value. Every byte features a parity bit (odd parity).

The data transmission can be interrupted at any time by deactivating  $\overline{CS}$ . If, for instance, the temperature information is not desired, the data transfer can be finished by deactivating  $\overline{CS}$  after reading the first two data bytes.

If the error flag is 0, the 13 angle data bits contain the most significant bits of the calculated angle. If the error flag is 1, an error condition was detected. The two least significant angle data bits (A[1:0]) are replaced by an error code. All other angle data bits (A[12:2]) still show the current measurement value. Depending on the special error case, the measurement values are reliable or not. Error codes are described in [Table 8](#).

The output driver of the DATA pin is slew-rate limited. The rise and fall times of the DATA output can be programmed with the SL bit (ctrl EEPROM constant); see [Table 12](#).

### Complementary digital output

In complementary digital output mode the data transmitted is identical to the output data in standard digital output mode except that the angle and temperature information data bits are logically inverted. The error flag and the error code in bits A[1:0] when the error flag is set are coded as in case of standard digital output. The parity bits also use odd parity as standard digital output mode.

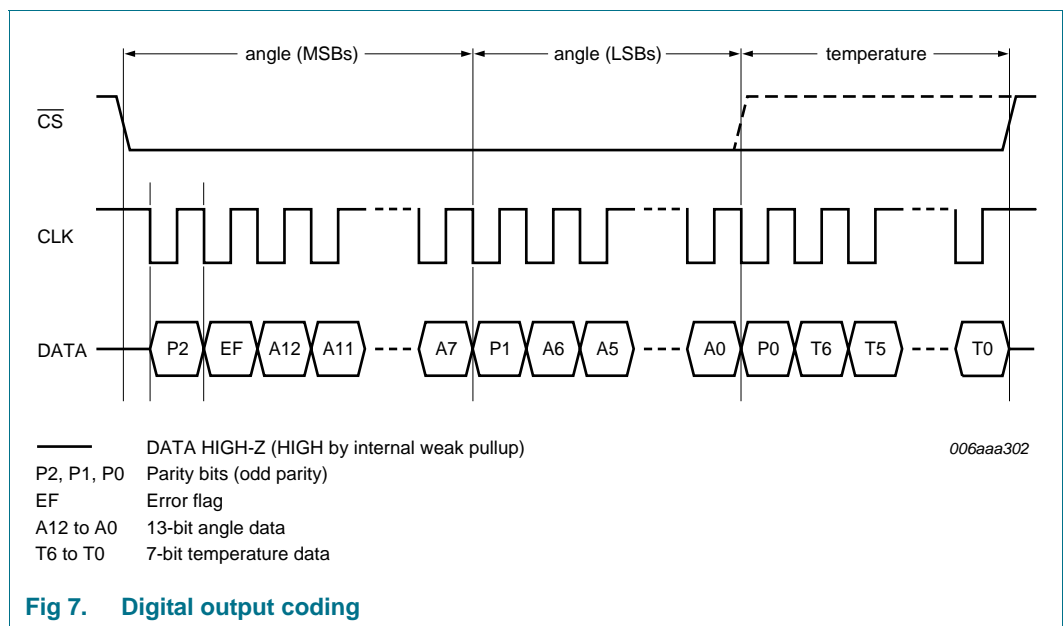

## 9. Limiting values

**Table 6. Limiting values**

*In accordance with the Absolute Maximum Rating System (IEC 60134).*

Symbol	Parameter	Conditions	Min	Max	Unit
V <sub>DD</sub>	supply voltage	pin V <sub>DD</sub> versus GND	-16.5	+26.5	V
		at t < 400 ms	-	32	V
V <sub>X</sub>	voltage on pins	$\overline{\text{CS}}$ , DATA/OUT1, CLK/OUT2 versus GND	0	100	%V <sub>DD</sub>
T <sub>amb</sub>	ambient temperature	< 1000 hours in life time at 160 °C	-40	+160	°C
T <sub>amb(pr)</sub>	programming ambient temperature	EEPROM	10	70	°C
T <sub>stg</sub>	storage temperature		-50	+150	°C
<b>EEPROM</b>					
t <sub>ret</sub>	retention time	T <sub>max(AV)</sub> = 50 °C	17	-	year
N <sub>endu(W_ER)</sub>	write or erase endurance	T <sub>max(AV)</sub> = 70 °C for programming	-	500	cycle

## 10. Characteristics

**Table 7. Characteristics**

In homogenous magnetic field at saturation field strength of minimum 35 kA/m and external capacitance  $C_{ext}$  between  $V_{DD}$  and GND.  $T_{amb} = -40\text{ °C}$  to  $+160\text{ °C}$ ;  $V_{DD} = 4.5\text{ V}$  to  $5.5\text{ V}$ .

Symbol	Parameter	Conditions	Min	Typ	Max	Unit
<b>Supply voltage and operation currents</b>						
$V_{DD}$	supply voltage	normal operation	4.5	5.0	5.5	V
$V_{DD(pr)}$	programming supply voltage	EEPROM	12	12.5	13	V
$I_{DD}$	supply current	for normal operation mode	5	-	12	mA
$C_L$	load capacitance	at pin 2 and pin 3	0.1	-	27	nF
$R_{L(pu)}$	pull-up load resistance		[1] 5	-	$\infty$	k $\Omega$
$R_{L(pd)}$	pull-down load resistance		[2][3] 5	-	10	k $\Omega$
$C_{ext}$	external capacitance between $V_{DD}$ and GND	conducted closely to supply pins of KMA200	82	-	120	nF
<b>Power-on reset</b>						
$V_{DDon}$	switch-on threshold voltage	KMA200 switches on if $V_{DD} > V_{DDon}$	3.1	3.75	4.45	V
$V_{DDoff}$	switch-off threshold voltage	KMA200 switches off if $V_{DD} < V_{DDoff}$	2.9	-	4.4	V
$V_{hys}$	hysteresis voltage	$V_{hys} = V_{DDon} - V_{DDoff}$	0.05	-	0.6	V
<b>System performance</b>						
<b>Analog output <math>V_{OUT1}</math>: standard output</b>						
$V_{OUT1(nom)}$	nominal output voltage range on pin OUT1		5	-	95	% $V_{DD}$
$V_{O(ldr)}$	lower diagnostic range output voltage	on OUT1	0	-	4	% $V_{DD}$
$V_{O(udr)}$	upper diagnostic range output voltage	on OUT1	96	-	100	% $V_{DD}$
$\alpha_{max}$	maximum angle	programmable from 0° to angle range $\alpha_{max}$ EEPROM address 3	0.1	-	180	deg
$V_{(CL)u}$	upper clamping voltage level	setting by EEPROM address 9	69.5	-	95	% $V_{DD}$
$V_{(CL)l}$	lower clamping voltage level	setting by EEPROM address 9	5	-	30.5	% $V_{DD}$
$\alpha_{res}$	angle resolution	4608 counts in nominal output voltage range (clamping level 5 % $V_{DD}$ to 95 % $V_{DD}$ )	[4] -	0.04	0.05	deg
$N_o$	output noise	peak to peak, 25 ms measurement time	[4] -	-	0.1	deg
$\Delta V_{(CL)}$	clamping voltage variation	at 5 % $V_{DD}$ and 95 % $V_{DD}$	[4] -0.3	-	+0.3	% $V_{DD}$
$\Delta\phi_{lin}$	angle linearity error	normal operation mode, deviation from reference line	[4] -1.65	-	+1.65	deg
$\Delta\phi_T$	angle temperature drift	valid for temperature range $-25\text{ °C}$ up to $+125\text{ °C}$ (3 sigma)	[4][5] -0.64	-	+0.64	deg
$\Delta\phi_{\mu lin}$	microlinearity	deviation at an angle step of 1°	[4] -0.1	-	+0.1	deg
$\Delta\phi_{hys}$	hysteresis	absolute value	[4] 0	-	0.088	deg

**Table 7. Characteristics ...continued**

In homogenous magnetic field at saturation field strength of minimum 35 kA/m and external capacitance  $C_{ext}$  between  $V_{DD}$  and GND.  $T_{amb} = -40\text{ °C}$  to  $+160\text{ °C}$ ;  $V_{DD} = 4.5\text{ V}$  to  $5.5\text{ V}$ .

Symbol	Parameter	Conditions	Min	Typ	Max	Unit
<b>Analog programmable output <math>V_{OUT2}</math>: mode 1</b>						
$V_{OUT2(nom)}$	nominal output voltage range on pin OUT2		5	-	95	% $V_{DD}$
$V_{O(ldr)}$	lower diagnostic range output voltage	on OUT2	0	-	4	% $V_{DD}$
$V_{O(udr)}$	upper diagnostic range output voltage	on OUT2	96	-	100	% $V_{DD}$
$\alpha_{max}$	maximum angle	programmable from 0° to angle range $\alpha_{max}$ EEPROM address 3	0.1	-	180	deg
$V_{(CL)u}$	upper clamping voltage level	setting by EEPROM address 9	69.5	-	95	% $V_{DD}$
$V_{(CL)l}$	lower clamping voltage level	setting by EEPROM address 9	5	-	30.5	% $V_{DD}$
$\alpha_{res}$	angle resolution	4608 counts in nominal output voltage range (clamping level 5 % $V_{DD}$ to 95 % $V_{DD}$ )	[4]	-	0.04	0.05 deg
$N_o$	output noise	peak to peak, 25 ms measurement time	[4]	-	-	0.1 deg
$\Delta V_{(CL)}$	clamping voltage variation	at 5 % $V_{DD}$ and 95 % $V_{DD}$	[4]	-0.3	-	+0.3 % $V_{DD}$
$\Delta\phi_{lin}$	angle linearity error	normal operation mode, deviation from reference line	[4]	-1.65	-	+1.65 deg
$\Delta\phi_T$	angle temperature drift	valid for temperature range $-25\text{ °C}$ up to $+125\text{ °C}$ (3 sigma)	[4][5]	-0.64	-	+0.64 deg
$\Delta\phi_{\mu lin}$	microlinearity	deviation at an angle step of 1°	[4]	-0.1	-	+0.1 deg
$\Delta\phi_{hys}$	hysteresis	absolute value	[4]	0	-	0.088 deg
$V_{pl(mode1)}$	plausibility $V_{OUT1}$ to $V_{OUT2}$ (mode 1)	$ V_{OUT1} + V_{OUT2} - V_{DD}  \leq V_{pl(mode1)}$	[4]	-0.5	-	+0.5 % $V_{DD}$

**Table 7. Characteristics ...continued**

In homogenous magnetic field at saturation field strength of minimum 35 kA/m and external capacitance  $C_{ext}$  between  $V_{DD}$  and GND.  $T_{amb} = -40\text{ °C}$  to  $+160\text{ °C}$ ;  $V_{DD} = 4.5\text{ V}$  to  $5.5\text{ V}$ .

Symbol	Parameter	Conditions	Min	Typ	Max	Unit	
<b>Analog programmable output <math>V_{OUT2}</math>: mode 2</b>							
$V_{OUT2(nom)}$	nominal output voltage range on pin OUT2		2.5	-	47.5	% $V_{DD}$	
$V_{O(ldr)}$	lower diagnostic range output voltage	on OUT2	0	-	2	% $V_{DD}$	
$V_{O(udr)}$	upper diagnostic range output voltage	on OUT2	50	-	100	% $V_{DD}$	
$\alpha_{res}$	angle resolution	2304 counts in nominal output voltage range with clamping level 5 % $V_{DD}$ to 95 % $V_{DD}$	[4]	-	0.08	-	deg
$\alpha_{max}$	maximum angle	programmable from 0° to angle range $\alpha_{max}$ EEPROM address 3	0.1	-	180		deg
$N_o$	output noise	peak to peak, 25 ms measurement time	[4]	-	-	0.2	deg
$\Delta V_{(CL)}$	clamping voltage variation	at 2.5 % $V_{DD}$ and 47.5 % $V_{DD}$	[4]	-0.3	-	+0.3	% $V_{DD}$
$\Delta\phi_{lin}$	angle linearity error	normal operation mode, deviation from reference line	[4]	-2.0	-	+2.0	deg
$\Delta\phi_T$	angle temperature drift	valid for temperature range $-25\text{ °C}$ up to $+125\text{ °C}$ (3 sigma)	[4][5]	-0.64	-	+0.64	deg
$\Delta\phi_{\mu lin}$	microlinearity	deviation at an angle step of 1°	[4]	-0.2	-	+0.2	deg
$\Delta\phi_{hys}$	hysteresis	absolute value	[4]	0	-	0.088	deg
$V_{pl(mode2)}$	plausibility $V_{OUT1}$ to $V_{OUT2}$ (mode 2)	$ V_{OUT1} - 2 \times V_{OUT2}  \leq V_{pl(mode2)}$		-0.7	-	+0.7	% $V_{DD}$
<b>Analog programmable output <math>V_{OUT2}</math>: mode 3</b>							
$V_{OUT2(L)}$	LOW-level output voltage on pin OUT2		0	-	10	% $V_{DD}$	
$V_{OUT2(H)}$	HIGH-level output voltage on pin OUT2		90	-	100	% $V_{DD}$	
$\alpha_{th(res)}$	threshold angle resolution	setting by EEPROM address 4	-	-	16	bit	
<b>Digital output and complement digital output</b>							
$\alpha_{res(dig)}$	digital angle resolution		-	0.022	-	deg/LSB	
$N_{dig}$	digital noise level	noise: 10 measurements in sequence	-	-	4	LSB	
$\Delta\phi_{lin}$	angle linearity error	normal operation mode from reference line		-1.65	-	+1.65	deg
$\Delta\phi_T$	angle temperature drift			-1.3	-	+1.3	deg
		valid for temperature range $-25\text{ °C}$ up to $+125\text{ °C}$ (3 sigma)		-0.5	-	+0.5	deg
$\Delta\phi_{\mu lin}$	microlinearity			-0.088	-	+0.088	deg
$\Delta\phi_{hys}$	hysteresis	absolute value		0	-	0.088	deg

**Table 7. Characteristics ...continued**

In homogenous magnetic field at saturation field strength of minimum 35 kA/m and external capacitance  $C_{ext}$  between  $V_{DD}$  and GND.  $T_{amb} = -40\text{ °C}$  to  $+160\text{ °C}$ ;  $V_{DD} = 4.5\text{ V}$  to  $5.5\text{ V}$ .

Symbol	Parameter	Conditions	Min	Typ	Max	Unit
<b>On-chip temperature sensor characteristics</b>						
$T_{sen}$	sensor temperature	chip temperature	-50	-	+180	°C
$T_{sen(res)}$	sensor temperature resolution	chip temperature	-	2	-	°C/LSB
$\Delta T_{sen}$	sensor temperature accuracy	chip temperature	-5	-	+5	°C
$T_{warn(res)}$	warning temperature resolution	setting by EEPROM address 6	-	2	-	°C
$T_{shut(res)}$	shut-down temperature resolution	setting by EEPROM address 6	-	2	-	°C
<b>SPI characteristics</b>						
$V_{IL}$	LOW-level input voltage	for $V_X = CLK, \overline{CS}, DATA$	0	-	25	% $V_{DD}$
$V_{IH}$	HIGH-level input voltage	for $V_X = CLK, \overline{CS}, DATA$	75	-	100	% $V_{DD}$
$V_{OL}$	LOW-level output voltage	$I_{sink} < 2\text{ mA}$	0	-	15	% $V_{DD}$
$V_{OH}$	HIGH-level output voltage	$I_{source} < 2\text{ mA}$	85	-	100	% $V_{DD}$
$I_{OM}$	peak output current	current limitation of the device	-	-	20	mA
$t_{r(o)}$	output rise time	normal operation mode from 10 % $V_{DD}$ to 90 % $V_{DD}$ , $C_L = 100\text{ pF}$	100	-	400	ns
	(SL bit = 0)					
$t_{f(o)}$	output fall time	normal operation mode from 10 % $V_{DD}$ to 90 % $V_{DD}$ , $C_L = 100\text{ pF}$	500	-	1300	ns
	(SL bit = 1)					
$t_{f(o)}$	output fall time	normal operation mode from 10 % $V_{DD}$ to 90 % $V_{DD}$ , $C_L = 100\text{ pF}$	100	-	400	ns
	(SL bit = 0)					
$t_{f(o)}$	output fall time	normal operation mode from 10 % $V_{DD}$ to 90 % $V_{DD}$ , $C_L = 100\text{ pF}$	500	-	1300	ns
	(SL bit = 1)					
$f_{clk}$	clock frequency	for $V_X = CLK$	1	-	1000	kHz
<b>Dynamics</b>						
$t_{pu}$	power-up time	until first valid result	-	-	10	ms
$f_{upd(meas)}$	measurement update rate	at oscillator frequency	3	4	5	kHz
$t_s$	settling time	after ideal input angle step until analog standard output reaches 90 % of final value, at nominal oscillator frequency, $C_L = 5\text{ nF}$	-	1	1.8	ms

- [1] Diagnosis GND and  $V_{DD}$  lost only possible with a pull-up resistor of 5 k $\Omega$  to 6 k $\Omega$ .
- [2] Diagnosis  $V_{DD}$  lost only possible with a pull-down resistor of 5 k $\Omega$  to 6 k $\Omega$ .
- [3] Load resistor required to enable the diagnosis features. Infinite resistor load permitted for normal operation without the diagnosis features.
- [4] Analog outputs need to be low-pass filtered (corner frequency about 1.3 kHz).
- [5] See [Figure 9](#).



## 11. Error codes

**Table 8. Error codes**

A[1:0]	Description	Angle valid
00	diagnosis error	no
01	diagnosis error (input stage)	no
10	over-temperature warning	yes
11	(not occupied)	-

Standard digital output:

$$a = A[12:0] \cdot \frac{180^\circ}{2^{13}} \approx A[12:0] \cdot 0.022^\circ \quad (1)$$

$$\text{Temperature} = -50^\circ\text{C} + T[6:0] \times 2^\circ\text{C}$$

Complement digital output:

$$a = \bar{A}[12:0] \cdot \frac{180^\circ}{2^{13}} \approx \bar{A}[12:0] \cdot 0.022^\circ \quad (2)$$

$$\text{Temperature} = -50^\circ\text{C} + \bar{T}[6:0] \times 2^\circ\text{C}$$

## 12. Definition of errors

### 12.1 General

For the accuracy is assumed that the sensor operates in a homogeneous magnetic field at saturation field strength  $H_{sat}$ . Also, the zero angle register of the KMA200 is set at a mechanical reference point at room temperature (and zero degree).

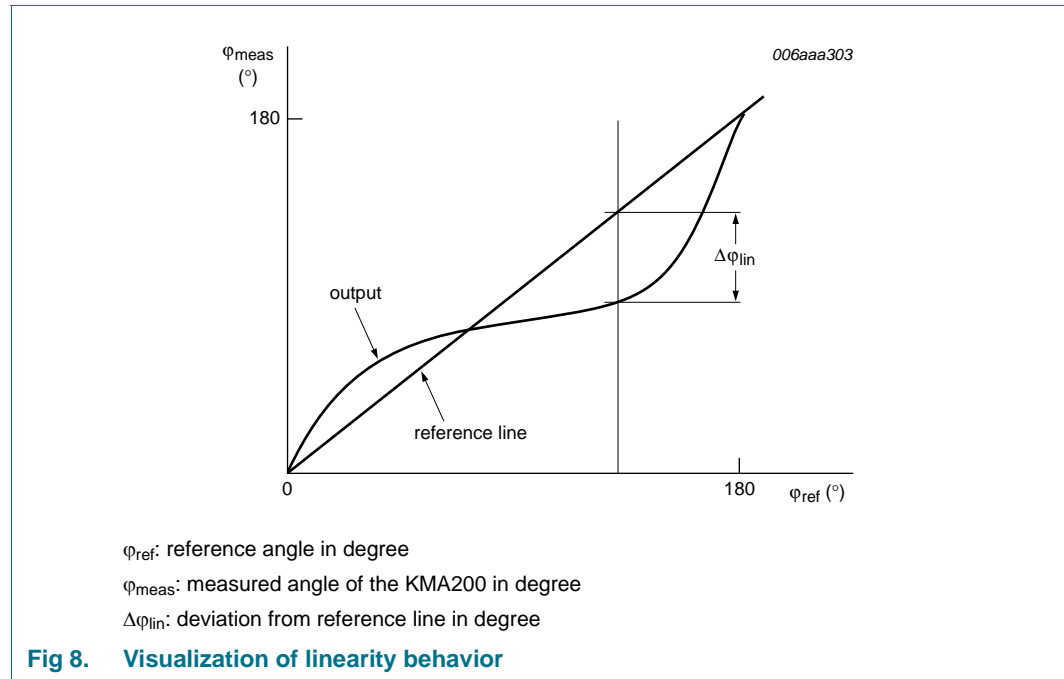

This reference line is valid for digital and analog outputs. The maximum angle is set to 180° and the clamping levels are programmed to  $V_{(CL)l} = 5\%V_{DD}$  and  $V_{(CL)u} = 95\%V_{DD}$ .

### 12.2 Linearity error

The deviation from the reference line  $\Delta\phi_{lin}$  is called angle linearity error and defined as follows:

$$\Delta\phi_{lin} = \phi_{lin}(\phi_{ref}, T_j) - \phi_{ref}$$

$T_j$ : any ambient temperature in the specific range

Following formula is used to calculate  $\phi_{meas}$  in degree from an analog voltage value:

$$\phi_{meas} = \frac{V_{OUT} - 5\%V_{DD}}{95\%V_{DD} - 5\%V_{DD}} \cdot 180^\circ \quad (3)$$

$V_{OUT}$ : analog output of KMA200 [% $V_{DD}$ ]

For sensors the error of the analog output  $\Delta\phi_{lin}$  is only defined in the range from 5.5 % $V_{DD}$  to 94.5 % $V_{DD}$ .

### 12.3 Temperature drift

The temperature drift is defined as the envelope deviation of the angle value over the temperature range. It is considered as the pure thermal effect.

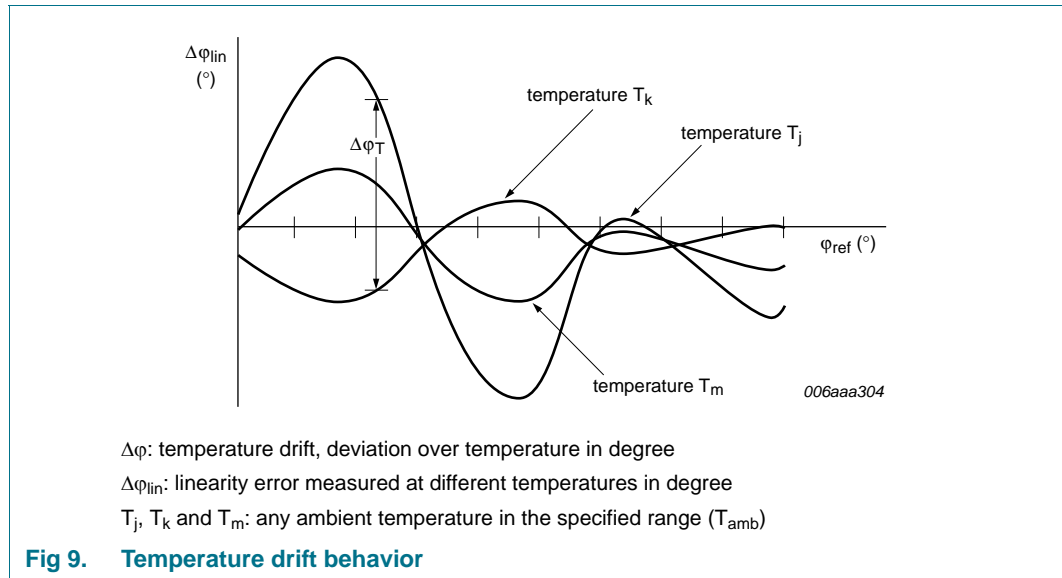

Following mathematical description is given for temperature drift value:

$$\Delta\phi_T = \phi_{meas}(\phi_{ref}, T_j) - \phi_{meas}(\phi_{ref}, T_k)$$

### 12.4 Microlinearity

Microlinearity is the deviation between the device output and the reference line at any angle and for an angle step of 1°. The microlinearity is determined at a constant temperature.

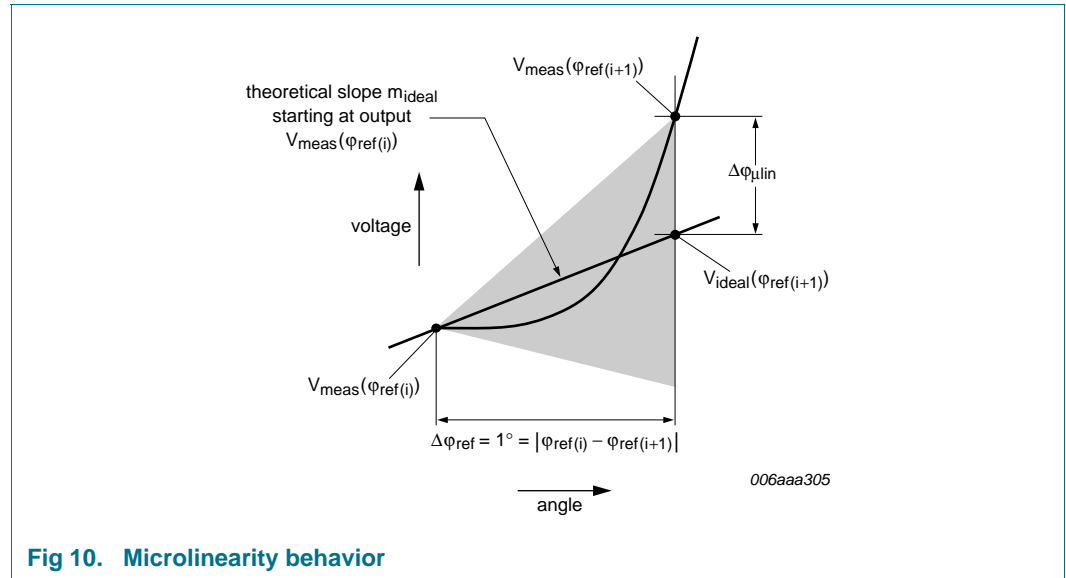

Fig 10. Microlinearity behavior

The microlinearity is calculated as follows:

$$\Delta\phi_{\mu lin} = V_{meas}(\phi_{ref(i+1)}) - V_{ideal}(\phi_{ref(i+1)})$$

$$V_{ideal}(\phi_{ref(i+1)}) = V_{meas}(\phi_{ref(i)}) + m_{ideal} \times 1^\circ = V_{meas}(\phi_{ref(i)}) + 0.5 \%V_{DD}$$

$\Delta\phi_{\mu lin}$ : microlinearity

$V_{meas}(\phi_{ref(i)})$ : measured voltage [% $V_{DD}$ ] for angle position  $\phi_{ref(i)}$

$m_{ideal}$ : ideal, theoretical slope; with 90 % $V_{DD}$  and maximum angle 180°

The output slopes are monotonic by design. This figures can also be used for the definition of  $\Delta\phi_{\mu lin}$  in digital mode, as follows: assume that

$$V_{meas}(\phi_{ref(i)}) = \phi_{meas}(\phi_{ref(i)}) \text{ and } V_{meas}(\phi_{ref(i+1)}) = \phi_{meas}(\phi_{ref(i+1)}),$$

whereas  $\phi_{meas}(X)$  is the output angle of the KMA200 at the angle position X.

## 12.5 Hysteresis

The hysteresis error is defined as the maximum difference between angle values given by the device output when performing a positive (clockwise) rotation and negative rotation (counter clockwise) over an angle range of 180°.

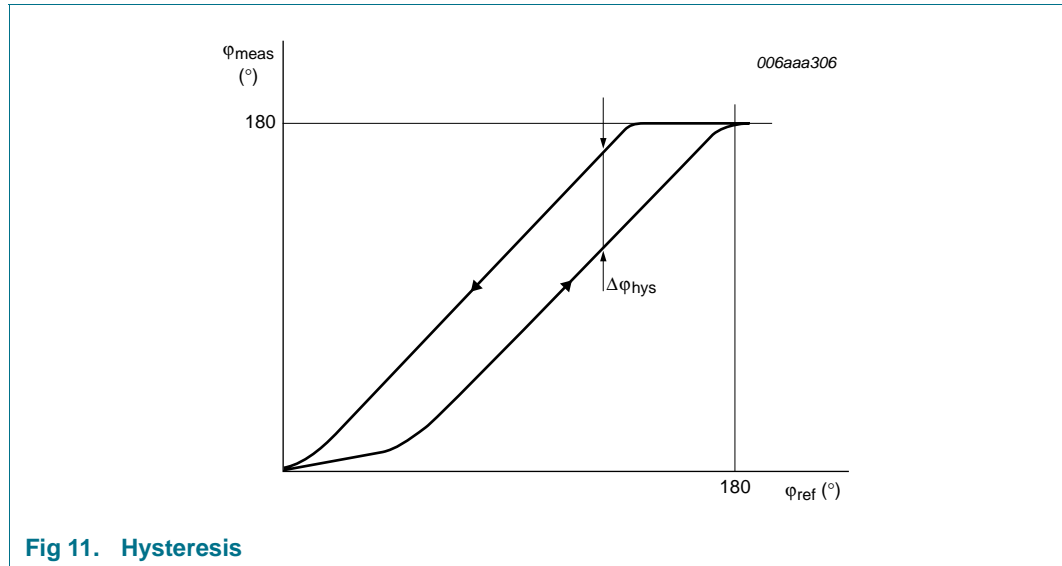

Fig 11. Hysteresis

The hysteresis error is defined as follows:

$$\Delta\phi_{\text{hys}} = |\phi_{\text{meas CW}}(\phi_{\text{ref}}) - \phi_{\text{meas CCW}}(\phi_{\text{ref}})|$$

$\Delta\phi_{\text{hys}}$ : hysteresis

$\phi_{\text{meas}}$ : CW measured angle for clockwise rotation

$\phi_{\text{meas}}$ : CCW measured angle for counter clockwise rotation

## 13. Programming

The KMA200 comprises two major modes of operation. These modes are:

### 13.1 Normal operation mode

This is the default mode. The KMA200 starts in this mode without the need of writing to the serial interface. In this mode a continuous conversion of the input signals into the corresponding angles takes place. This mode is configured with the on-chip EEPROM. Once in normal operation mode, the KMA200 can be reactivated for command mode only by a new power-on reset.

### 13.2 Command mode

This mode is used for calibration and programming. The KMA200 is controlled with serial interface commands.

To activate the command mode, the following initialization procedure must be executed during power-on reset. The pin  $\overline{CS}$  must be constantly held on HIGH level and pin CLK/OUT2 must be constantly held on LOW level during power-on. This condition has to start during reset and must be valid during the following initialization phase of the KMA200 for at least 1 ms.  $\overline{CS}$  and CLK are internally weak pull-up so that at least CLK must be actively driven. If these conditions are valid, the KMA200 starts in command mode. At all other combinations or if the levels are not constant for the minimum time of 1 ms, the KMA200 starts in normal operation mode.

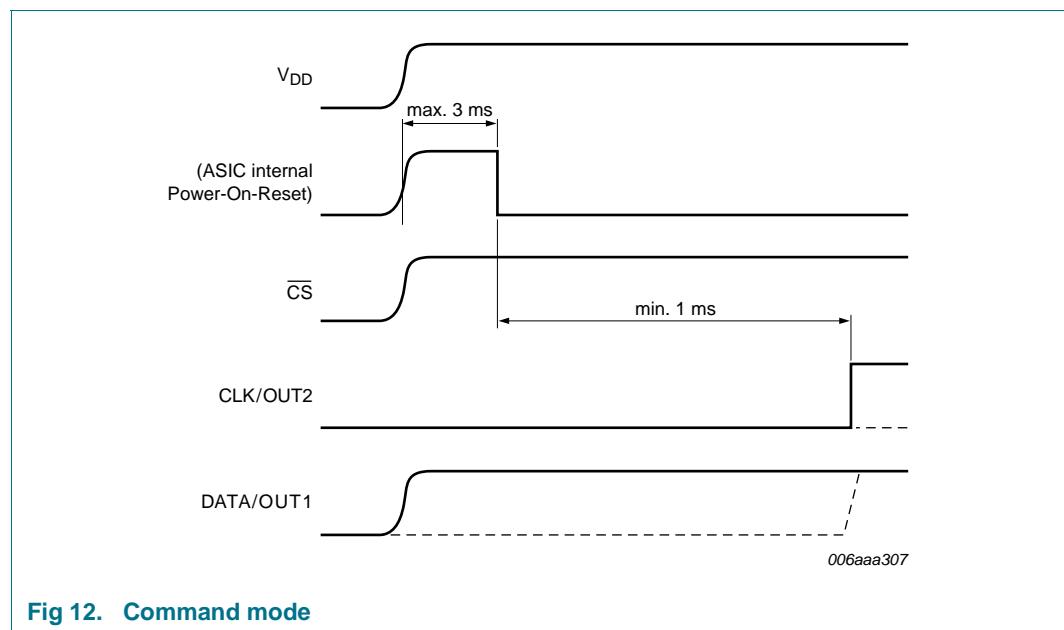

Fig 12. Command mode

The normal operation mode is configured with sixteen 16-bit constants stored in the on-chip EEPROM.

### 13.3 Notes to the programming

The KMA200 sensor is delivered in a pre-calibrated and preprogrammed default condition.

**The EEPROM addresses 0, 1, 5, C, D and E are device dependent and pre-calibrated for each device. A changing of this contents to another value is not allowed, because the specified data, influenced by these addresses, are no longer valid.**

The EEPROM addresses A and B are used to store production related information. A changing of these values should not be done.

Definition:

Address A: storage the date code. Date code assembly center: day of the year (maximum 365) + year (maximum 99)

Address B: storage the assembly lot no. (maximum 65535)

### 13.4 Write RAM (0nh), read RAM (1nh)

To write data to the RAM the command byte 0nh (n is the address of the data) followed by the 16-bit data has to be send. To read data from the RAM, the command byte 1nh has to be send. If  $\overline{CS}$  is activated again, the RAM contents at the specified address is clocked out. Note that at power-on addresses 00h to 0Fh are read from the EEPROM into the RAM.

### 13.5 Calculate CRC-16 and program EEPROM (30h)

To program the EEPROM, the configuration data has to be written to the RAM addresses 00h to 0Eh. Afterwards, the command byte 30h has to be sent and the EEPROM programming voltage has to be applied at the  $V_{DD}$  pin. The KMA200 calculates the CRC-16 check sum and writes the RAM constants at addresses 00h to 0Fh to the EEPROM. This command is only executed when the EP bit in the control information word is logic 0 on power-on. If the EP bit is logic 1, this command is ignored.

**Table 9. EEPROM content**

Address	Name	Description
0	sensor_offset_1	dependent of individual production calibration results
1	sensor_offset_2	dependent of individual production calibration results
2	zero_angle	mechanical 0° position relative to the zero point of the sensor output; used for zero-angle calibration default value: 0000h (0°)
3	angular_range	definition of the angular input range that is mapped to the whole analog output signal range default value: 0000h (180°)
4	$\alpha_{\text{thresh}}$	threshold for programmable output in mode 3 default value: internal CRC of the addresses 0, 1, 5, C, D and E
5	temp_vref, temp_offs	dependent of individual production calibration results
6	$T_{\text{shut(res)}}$ , $T_{\text{warn(res)}}$	temperature warning and temperature shutdown level; used for temperature supervision default value: FAF8h (temperature shutdown at 200 °C, warning at 198 °C)
7	ctrl1	control information word 1; used for selection of various operating modes default value: 4046h (output mode standard + mode 1)
8	ctrl2	control information word 2; configures the diagnostic functions default value: 0704h (temperature supervision is on; input stage diagnosis is on; output stage diagnosis is off)
9	$V_{(CL)L}$ , $V_{(CL)u}$	clamping voltage levels of analog outputs default value: 00FFh (clamping level LOW at 5 % $V_{DD}$ , clamping level HIGH at 95 % $V_{DD}$ )
A	id1	sensor identifier 1; this data is not evaluated by the KMA200 and is used for sensor identification
B	id2	sensor identifier 2; this data is not evaluated by the KMA200 and is used for sensor identification
C	anom, tc_anom	dependent of individual production calibration results

**Table 9. EEPROM content ...continued**

Address	Name	Description
D	tc_offset_1	dependent of individual production calibration results
E	tc_offset_2	dependent of individual production calibration results
F	CRC-16	dependent of individual programming

**Table 10. Format of zero\_angle, angular\_range and  $\alpha_{thresh}$**

$zero\_angle = A[15:0] \times 0.00275^\circ$ ,  $angular\_range = A[15:0] \times 0.00275^\circ$  and  $\alpha_{thresh} = A[15:0] \times 0.00275^\circ$ .

MSB															LSB
15	14	13	12	11	10	9	8	7	6	5	4	3	2	1	0
A[15]	A[14]	A[13]	A[12]	A[11]	A[10]	A[9]	A[8]	A[7]	A[6]	A[5]	A[4]	A[3]	A[2]	A[1]	A[0]

**Table 11. Format of  $T_{shut(res)}$  and  $T_{warn(res)}$**

$T_{shut(res)} = -50\text{ }^\circ\text{C} + TS[7:0] \times 1\text{ }^\circ\text{C}$  and  $T_{warn(res)} = -50\text{ }^\circ\text{C} + TW[7:0] \times 1\text{ }^\circ\text{C}$ .

MSB															LSB
15	14	13	12	11	10	9	8	7	6	5	4	3	2	1	0
$T_{shut(res)}$								$T_{warn(res)}$							
TS	TS	TS	TS	TS	TS	TS	TS	TW	TW	TW	TW	TW	TW	TW	TW
[7]	[6]	[5]	[4]	[3]	[2]	[1]	[0]	[7]	[6]	[5]	[4]	[3]	[2]	[1]	[0]

**Table 12. Format of ctrl1**

MSB															LSB
15	14	13[1]	12	11[2]	10[3]	9[3]	8[4]	7[4]	6[5]	5[5]	4[5]	3	2	1	0
0	1	EP	0	SL	DO1	DO0	DI1	DI0	OM2	OM1	OM0	0	1	1	0

- [1] EP: EEPROM write protection: default value: 0  
 0  $\equiv$  EEPROM programming possible  
 1  $\equiv$  EEPROM not writable  
 This bit is evaluated only if the CRC checksum is valid.
- [2] SL: rise and fall time of DATA output: default value: 0  
 0  $\equiv$  nominal 150 ns  
 1  $\equiv$  nominal 750 ns
- [3] DO[1:0]: diagnosis of output stage: default value: 00  
 00  $\equiv$  level 0:  $|V_{meas(OUT)} - V_{exp(OUT)}| < 10\%V_{DD}$   
 01  $\equiv$  level 1:  $|V_{meas(OUT)} - V_{exp(OUT)}| < 5\%V_{DD}$   
 10  $\equiv$  level 2:  $|V_{meas(OUT)} - V_{exp(OUT)}| < 2\%V_{DD}$   
 11  $\equiv$  level 3:  $|V_{meas(OUT)} - V_{exp(OUT)}| < 1\%V_{DD}$
- [4] DI[2:0]: diagnosis of input stage: default value: 000  
 000  $\equiv$  level 0:  $|A_{Meas} - A_{Sol}| < 6.24\text{ mV/V}$   
 001  $\equiv$  level 1:  $|A_{Meas} - A_{Sol}| < 4.68\text{ mV/V}$   
 010  $\equiv$  level 2:  $|A_{Meas} - A_{Sol}| < 3.12\text{ mV/V}$   
 011  $\equiv$  level 3:  $|A_{Meas} - A_{Sol}| < 1.56\text{ mV/V}$   
 100  $\equiv$  level 4:  $|A_{Meas} - A_{Sol}| < 0.78\text{ mV/V}$
- [5] OM[2:0]: output mode: default value: 100  
 000  $\equiv$  digital output  
 001  $\equiv$  complement digital output  
 100  $\equiv$  analog output; standard + programmable output mode 1  
 101  $\equiv$  analog output; standard + programmable output mode 2  
 110  $\equiv$  analog output; standard + programmable output mode 3  
 111  $\equiv$  analog output; standard output only



Table 13. Format of ctrl2

MSB															LSB
15	14	13	12	11 <sup>[1]</sup>	10	9 <sup>[2]</sup>	8 <sup>[3]</sup>	7 <sup>[4]</sup>	6 <sup>[4]</sup>	5 <sup>[5]</sup>	4 <sup>[6]</sup>	3 <sup>[6]</sup>	2 <sup>[7]</sup>	1 <sup>[8]</sup>	0 <sup>[8]</sup>
0	0	0	0	DI2	1	FB	ETS	TC1	TC0	EDO	CO1	CO0	EDI	CI1	CI0

- [1] DI[2:0]: diagnosis of input stage: default value: 000  
 000 ≡ level 0:  $|A_{Meas} - A_{Sol}| < 6.24 \text{ mV/V}$   
 001 ≡ level 1:  $|A_{Meas} - A_{Sol}| < 4.68 \text{ mV/V}$   
 010 ≡ level 2:  $|A_{Meas} - A_{Sol}| < 3.12 \text{ mV/V}$   
 011 ≡ level 3:  $|A_{Meas} - A_{Sol}| < 1.56 \text{ mV/V}$   
 100 ≡ level 4:  $|A_{Meas} - A_{Sol}| < 0.78 \text{ mV/V}$
- [2] FB: automatic fallback into normal operation mode: default value: 1  
 0 ≡ disabled  
 1 ≡ enabled  
 This bit is evaluated only if the CRC checksum is valid.
- [3] ETS: enable temperature supervision: default value: 1  
 0 ≡ disabled  
 1 ≡ enabled
- [4] TC[1:0]: error counter temperature supervision: default value: 00  
 00 ≡ 0  
 01 ≡ 2  
 10 ≡ 4  
 11 ≡ 8
- [5] EDO: enable diagnosis output stage: default value: 0  
 0 ≡ disabled  
 1 ≡ enabled
- [6] CO[1:0]: error counter diagnosis output stage: default value: 00  
 00 ≡ 0  
 01 ≡ 2  
 10 ≡ 4  
 11 ≡ 8
- [7] EDI: enable diagnosis input stage: default value: 1  
 0 ≡ disabled  
 1 ≡ enabled
- [8] CI[1:0]: error counter diagnosis input stage: default value: 00  
 00 ≡ 0  
 01 ≡ 2  
 10 ≡ 4  
 11 ≡ 8

Table 14. Format of  $V_{(CL)l}$  and  $V_{(CL)u}$

Lower clamping level output voltage =  $5 \%V_{DD} + V_{(CL)l} \times 0.1 \%V_{DD}$  and  
 upper clamping level output voltage =  $69.5 \%V_{DD} + V_{(CL)u} \times 0.1 \%V_{DD}$ .

MSB															LSB
15	14	13	12	11	10	9	8	7	6	5	4	3	2	1	0
$V_{(CL)l}$								$V_{(CL)u}$							
2 <sup>7</sup>	2 <sup>6</sup>	2 <sup>5</sup>	2 <sup>4</sup>	2 <sup>3</sup>	2 <sup>2</sup>	2 <sup>1</sup>	2 <sup>0</sup>	2 <sup>7</sup>	2 <sup>6</sup>	2 <sup>5</sup>	2 <sup>4</sup>	2 <sup>3</sup>	2 <sup>2</sup>	2 <sup>1</sup>	2 <sup>0</sup>

## 14. ElectroMagnetic Interference (EMI)

---

The following tests are performed with the sensor system KMA200. Details of the measurements and behavior are available on request.

### 14.1 Emission (CISPR 25)

Conducted radio disturbance: tests according CISPR 25, chapter 11 (artificial network).

Radiated radio disturbance: test according CISPR 25, chapter 13 (anechoic chamber - component/module).

### 14.2 Radiated disturbances (ISO 11452-2, ISO 11452-5)

Immunity against mobile phones and Absorber Lined Chamber and Strip line (ALCS); strip line measurements are performed up to 1 GHz.

### 14.3 Transients - pulses (ISO 7637-1, ISO 7637-3)

Galvanic: line conducted pulses on the supply lines according ISO 7637-1 pulses 1, 2, 3a, 3b, 4 and 5 (for pulse no. 5 a suitable protection circuit must be used).

Coupled: transient transmission by capacitive and inductive coupling via lines other than supply lines (interface, analog output) according ISO 7637-3 pulses 3a and 3b.

## 15. ElectroStatic Discharge (ESD)

---

### 15.1 Human body model

The KMA200 must not be damaged at 4000 V, 100 pF, 1.5 k $\Omega$  to the human body model. The test is according to MIL-STD-883D method 3015.7. This protection must be ensured at all external pins (CLK/OUT2, CS and DATA/OUT1) including device supply (V<sub>DD</sub>, GND). For the interconnects (pins between upper and lower package part), the protection is up to 1500 V.

### 15.2 Machine model

The KMA200 must not be damaged at 400 V to the machine model. The test is according to MIL-STD-883D method 3015.7. This protection must be ensured at all external pins (CLK/OUT2, CS and DATA/OUT1) including device supply (V<sub>DD</sub>, GND). For the interconnects (pins between upper and lower package part), the protection is up to 100 V.

## 16. Terminals

---

Device terminals shall be compatible with laser welding and electrical welding.

Lead frame material: CuZr with 0.1 % Zr, 99.9 % Cu

Lead finish: pure tin, 7  $\mu\text{m}$   $\leq$  thickness  $\leq$  11  $\mu\text{m}$

## 17. Marking

---

Package is SOT637

Marking paint: laser on package head and package body

Letter height: 0.8 mm

Marking of package head: batch number

Marking of package body: type no., date code (x yyy z); x: m for manufacturing Manila,  
y: day of the year, z: year of production

18. Package outline

Plastic single-ended multi-chip package; 6 interconnections; 5 in-line leads

SOT637

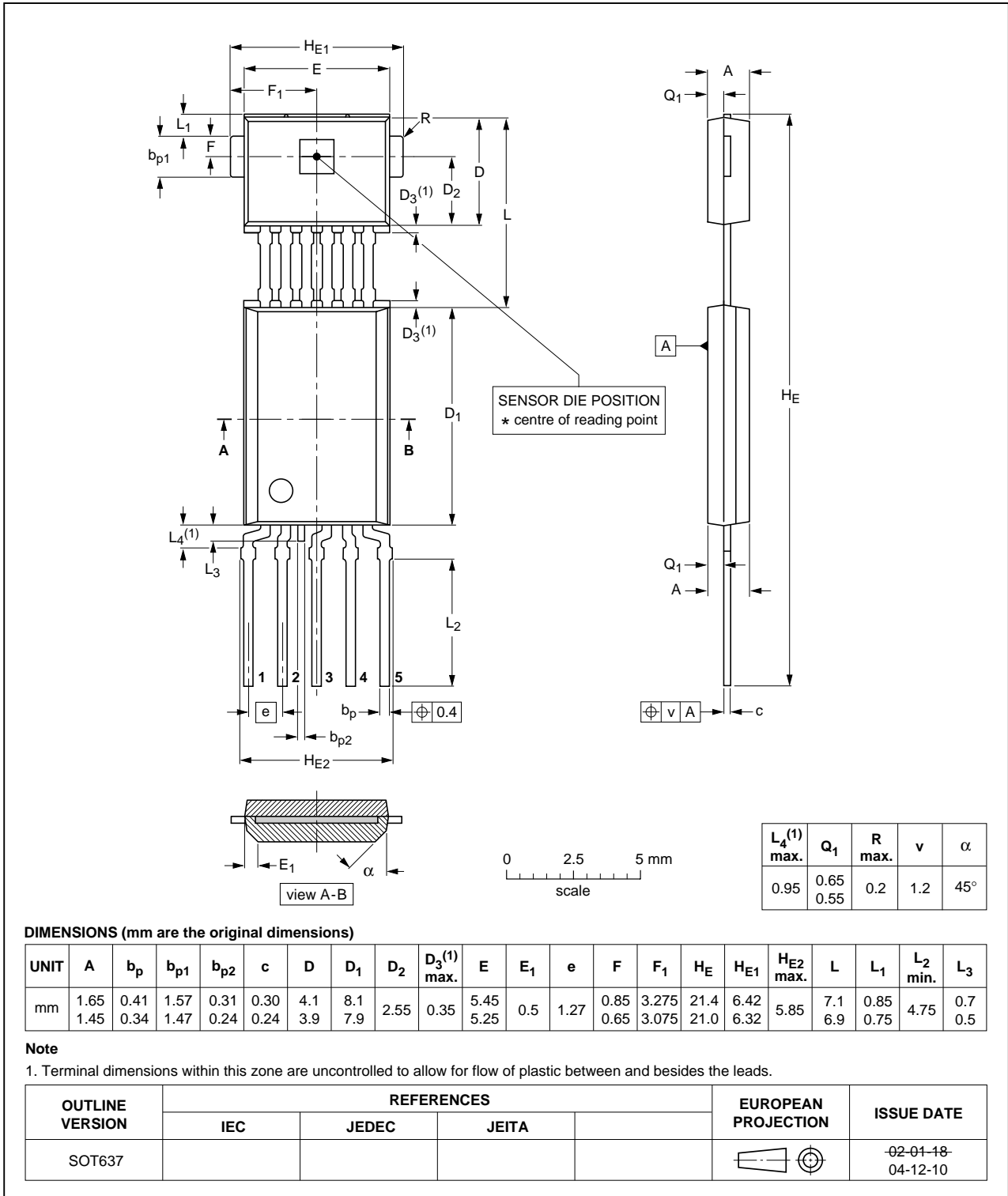
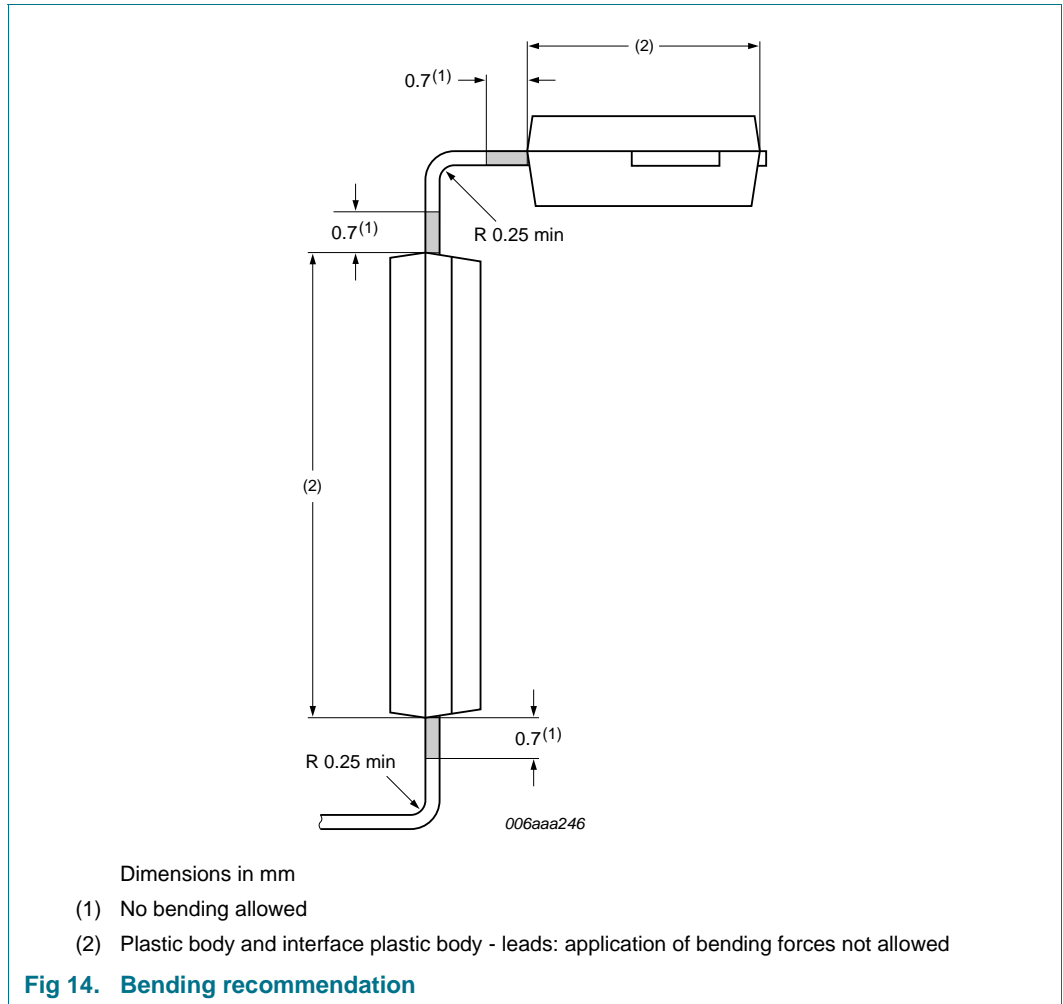

Fig 13. Package outline SOT637

**19. Handling information**



## 20. Revision history

Table 15. Revision history

Document ID	Release date	Data sheet status	Change notice	Supersedes
KMA200_8	20111207	Product data sheet	PCN 201106032F01	KMA200_7
Modifications:	• <a href="#">Section 16 "Terminals"</a> : Lead finish dimensions changed			
KMA200_7	20080718	Product data sheet	-	KMA200_6
Modifications:	• Section 16: The lead finish thickness has been changed			
KMA200_6	20070102	Product data sheet	-	KMA200_5
KMA200_5	20050816	Product data sheet	-	KMA200_4
KMA200_4	20020325	Objective specification	-	KMA200_3
KMA200_3	20010620	Objective specification	-	KMA200_2
KMA200_2	20000920	Objective specification	-	KMA200_1
KMA200_1	20000907	Objective specification	-	-

## 21. Legal information

### 21.1 Data sheet status

Document status <sup>[1][2]</sup>	Product status <sup>[3]</sup>	Definition
Objective [short] data sheet	Development	This document contains data from the objective specification for product development.
Preliminary [short] data sheet	Qualification	This document contains data from the preliminary specification.
Product [short] data sheet	Production	This document contains the product specification.

[1] Please consult the most recently issued document before initiating or completing a design.

[2] The term 'short data sheet' is explained in section "Definitions".

[3] The product status of device(s) described in this document may have changed since this document was published and may differ in case of multiple devices. The latest product status information is available on the Internet at URL <http://www.nxp.com>.

### 21.2 Definitions

**Draft** — The document is a draft version only. The content is still under internal review and subject to formal approval, which may result in modifications or additions. NXP Semiconductors does not give any representations or warranties as to the accuracy or completeness of information included herein and shall have no liability for the consequences of use of such information.

**Short data sheet** — A short data sheet is an extract from a full data sheet with the same product type number(s) and title. A short data sheet is intended for quick reference only and should not be relied upon to contain detailed and full information. For detailed and full information see the relevant full data sheet, which is available on request via the local NXP Semiconductors sales office. In case of any inconsistency or conflict with the short data sheet, the full data sheet shall prevail.

**Product specification** — The information and data provided in a Product data sheet shall define the specification of the product as agreed between NXP Semiconductors and its customer, unless NXP Semiconductors and customer have explicitly agreed otherwise in writing. In no event however, shall an agreement be valid in which the NXP Semiconductors product is deemed to offer functions and qualities beyond those described in the Product data sheet.

### 21.3 Disclaimers

**Limited warranty and liability** — Information in this document is believed to be accurate and reliable. However, NXP Semiconductors does not give any representations or warranties, expressed or implied, as to the accuracy or completeness of such information and shall have no liability for the consequences of use of such information.

In no event shall NXP Semiconductors be liable for any indirect, incidental, punitive, special or consequential damages (including - without limitation - lost profits, lost savings, business interruption, costs related to the removal or replacement of any products or rework charges) whether or not such damages are based on tort (including negligence), warranty, breach of contract or any other legal theory.

Notwithstanding any damages that customer might incur for any reason whatsoever, NXP Semiconductors' aggregate and cumulative liability towards customer for the products described herein shall be limited in accordance with the *Terms and conditions of commercial sale* of NXP Semiconductors.

**Right to make changes** — NXP Semiconductors reserves the right to make changes to information published in this document, including without limitation specifications and product descriptions, at any time and without notice. This document supersedes and replaces all information supplied prior to the publication hereof.

**Suitability for use in automotive applications** — This NXP Semiconductors product has been qualified for use in automotive applications. Unless otherwise agreed in writing, the product is not designed,

authorized or warranted to be suitable for use in life support, life-critical or safety-critical systems or equipment, nor in applications where failure or malfunction of an NXP Semiconductors product can reasonably be expected to result in personal injury, death or severe property or environmental damage. NXP Semiconductors accepts no liability for inclusion and/or use of NXP Semiconductors products in such equipment or applications and therefore such inclusion and/or use is at the customer's own risk.

**Applications** — Applications that are described herein for any of these products are for illustrative purposes only. NXP Semiconductors makes no representation or warranty that such applications will be suitable for the specified use without further testing or modification.

Customers are responsible for the design and operation of their applications and products using NXP Semiconductors products, and NXP Semiconductors accepts no liability for any assistance with applications or customer product design. It is customer's sole responsibility to determine whether the NXP Semiconductors product is suitable and fit for the customer's applications and products planned, as well as for the planned application and use of customer's third party customer(s). Customers should provide appropriate design and operating safeguards to minimize the risks associated with their applications and products.

NXP Semiconductors does not accept any liability related to any default, damage, costs or problem which is based on any weakness or default in the customer's applications or products, or the application or use by customer's third party customer(s). Customer is responsible for doing all necessary testing for the customer's applications and products using NXP Semiconductors products in order to avoid a default of the applications and the products or of the application or use by customer's third party customer(s). NXP does not accept any liability in this respect.

**Limiting values** — Stress above one or more limiting values (as defined in the Absolute Maximum Ratings System of IEC 60134) will cause permanent damage to the device. Limiting values are stress ratings only and (proper) operation of the device at these or any other conditions above those given in the Recommended operating conditions section (if present) or the Characteristics sections of this document is not warranted. Constant or repeated exposure to limiting values will permanently and irreversibly affect the quality and reliability of the device.

**Terms and conditions of commercial sale** — NXP Semiconductors products are sold subject to the general terms and conditions of commercial sale, as published at <http://www.nxp.com/profile/terms>, unless otherwise agreed in a valid written individual agreement. In case an individual agreement is concluded only the terms and conditions of the respective agreement shall apply. NXP Semiconductors hereby expressly objects to applying the customer's general terms and conditions with regard to the purchase of NXP Semiconductors products by customer.

**No offer to sell or license** — Nothing in this document may be interpreted or construed as an offer to sell products that is open for acceptance or the grant, conveyance or implication of any license under any copyrights, patents or other industrial or intellectual property rights.

**Export control** — This document as well as the item(s) described herein may be subject to export control regulations. Export might require a prior authorization from competent authorities.

**Quick reference data** — The Quick reference data is an extract of the product data given in the Limiting values and Characteristics sections of this document, and as such is not complete, exhaustive or legally binding.

## 21.4 Trademarks

Notice: All referenced brands, product names, service names and trademarks are the property of their respective owners.

## 22. Contact information

---

For more information, please visit: <http://www.nxp.com>

For sales office addresses, please send an email to: [salesaddresses@nxp.com](mailto:salesaddresses@nxp.com)



## 23. Contents

<b>1</b>	<b>Product profile</b> . . . . .	<b>1</b>	<b>21.3</b>	Disclaimers . . . . .	<b>31</b>
1.1	General description . . . . .	1	21.4	Trademarks . . . . .	32
1.2	Features and benefits . . . . .	1	<b>22</b>	<b>Contact information</b> . . . . .	<b>32</b>
1.3	Quick reference data . . . . .	2	<b>23</b>	<b>Contents</b> . . . . .	<b>33</b>
<b>2</b>	<b>Pinning information</b> . . . . .	<b>2</b>			
<b>3</b>	<b>Ordering information</b> . . . . .	<b>2</b>			
<b>4</b>	<b>Functional diagram</b> . . . . .	<b>3</b>			
<b>5</b>	<b>Functional description</b> . . . . .	<b>4</b>			
<b>6</b>	<b>Diagnostic features</b> . . . . .	<b>5</b>			
<b>7</b>	<b>Outputs of KMA200</b> . . . . .	<b>8</b>			
<b>8</b>	<b>Digital output (SPI)</b> . . . . .	<b>11</b>			
<b>9</b>	<b>Limiting values</b> . . . . .	<b>12</b>			
<b>10</b>	<b>Characteristics</b> . . . . .	<b>13</b>			
<b>11</b>	<b>Error codes</b> . . . . .	<b>17</b>			
<b>12</b>	<b>Definition of errors</b> . . . . .	<b>18</b>			
12.1	General . . . . .	18			
12.2	Linearity error . . . . .	18			
12.3	Temperature drift . . . . .	19			
12.4	Microlinearity . . . . .	20			
12.5	Hysteresis . . . . .	21			
<b>13</b>	<b>Programming</b> . . . . .	<b>21</b>			
13.1	Normal operation mode . . . . .	21			
13.2	Command mode . . . . .	22			
13.3	Notes to the programming . . . . .	22			
13.4	Write RAM (0nh), read RAM (1nh) . . . . .	23			
13.5	Calculate CRC-16 and program EEPROM (30h) . . . . .	23			
<b>14</b>	<b>ElectroMagnetic Interference (EMI)</b> . . . . .	<b>26</b>			
14.1	Emission (CISPR 25) . . . . .	26			
14.2	Radiated disturbances (ISO 11452-2, ISO 11452-5) . . . . .	26			
14.3	Transients - pulses (ISO 7637-1, ISO 7637-3) . . . . .	26			
<b>15</b>	<b>ElectroStatic Discharge (ESD)</b> . . . . .	<b>26</b>			
15.1	Human body model . . . . .	26			
15.2	Machine model . . . . .	26			
<b>16</b>	<b>Terminals</b> . . . . .	<b>26</b>			
<b>17</b>	<b>Marking</b> . . . . .	<b>27</b>			
<b>18</b>	<b>Package outline</b> . . . . .	<b>28</b>			
<b>19</b>	<b>Handling information</b> . . . . .	<b>29</b>			
<b>20</b>	<b>Revision history</b> . . . . .	<b>30</b>			
<b>21</b>	<b>Legal information</b> . . . . .	<b>31</b>			
21.1	Data sheet status . . . . .	31			
21.2	Definitions . . . . .	31			

Please be aware that important notices concerning this document and the product(s) described herein, have been included in section 'Legal information'.

© NXP B.V. 2011.

All rights reserved.

For more information, please visit: <http://www.nxp.com>

For sales office addresses, please send an email to: [salesaddresses@nxp.com](mailto:salesaddresses@nxp.com)

Date of release: 7 December 2011

Document identifier: KMA200