

## Features

- Serial Peripheral Interface (SPI) Compatible
- Supports SPI Modes 0 (0,0) and 3 (1,1)
- Data Sheet Describes Mode 0 Operation
- Low-voltage Operation
  - 1.8 ( $V_{CC} = 1.8V$  to 3.6V)
- 10 MHz Clock Rate (2.7 – 3.6V)
- 128-byte Page Mode and Byte Write Operation Supported
- Block Write Protection
  - Protect 1/4, 1/2, or Entire Array
- Write Protect (WP) Pin and Write Disable Instructions for Both Hardware and Software Data Protection
- Self-timed Write Cycle (5 ms Max)
- High-reliability
  - Endurance: 1 Million Write Cycles
  - Data Retention: >40 Years
- Automotive Grade Temperature Available
- Lead-free/Halogen-free Devices
- 8-lead JEDEC SOIC, 8-lead TSSOP and 8-lead SAP Packages
- Die Sales: Wafer Form, Waffle Pack, and Bumped Die

## Description

The AT25512 provides 524,288 bits of serial electrically-erasable programmable read only memory (EEPROM) organized as 65,536 words of 8 bits each. The device is optimized for use in many industrial and commercial applications where low-power and low-voltage operation are essential. The devices are available in space saving 8-lead JEDEC SOIC, 8-lead TSSOP and 8-lead SAP packages. In addition, the entire family is available in 1.8V (1.8V to 3.6V) versions.

The AT25512 is enabled through the Chip Select pin ( $\overline{CS}$ ) and accessed via a 3-wire interface consisting of Serial Data Input (SI), Serial Data Output (SO), and Serial Clock (SCK). All programming cycles are completely self-timed, and no separate Erase cycle is required before Write.

**Table 1.** Pin Configurations

Pin Name	Function
$\overline{CS}$	Chip Select
SCK	Serial Data Clock
SI	Serial Data Input
SO	Serial Data Output
GND	Ground
VCC	Power Supply
$\overline{WP}$	Write Protect
$\overline{HOLD}$	Suspends Serial Input
NC	No Connect

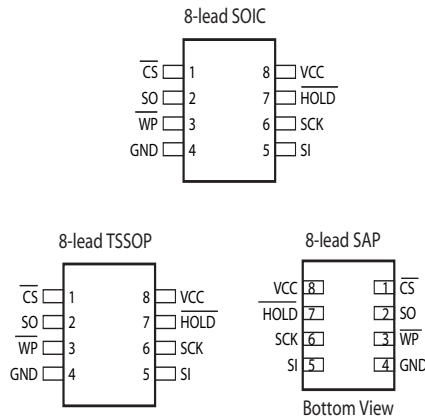

## SPI Serial EEPROM

512K (65,536 x 8)

## AT25512

## Advance Information



Block Write protection is enabled by programming the status register with top ¼, top ½ or entire array of write protection. Separate Program Enable and Program Disable instructions are provided for additional data protection. Hardware data protection is provided via the WP pin to protect against inadvertent write attempts to the status register. The HOLD pin may be used to suspend any serial communication without resetting the serial sequence.

### Absolute Maximum Ratings\*

Operating Temperature.....	-55°C to +125°C
Storage Temperature .....	-65°C to +150°C
Voltage on Any Pin with Respect to Ground.....	-1.0V to +5.0V
Maximum Operating Voltage .....	4.3V
DC Output Current.....	5.0 mA

\*NOTICE: Stresses beyond those listed under “Absolute Maximum Ratings” may cause permanent damage to the device. This is a stress rating only and functional operation of the device at these or any other conditions beyond those indicated in the operational sections of this specification is not implied. Exposure to absolute maximum rating conditions for extended periods may affect device reliability.

Figure 1. Block Diagram

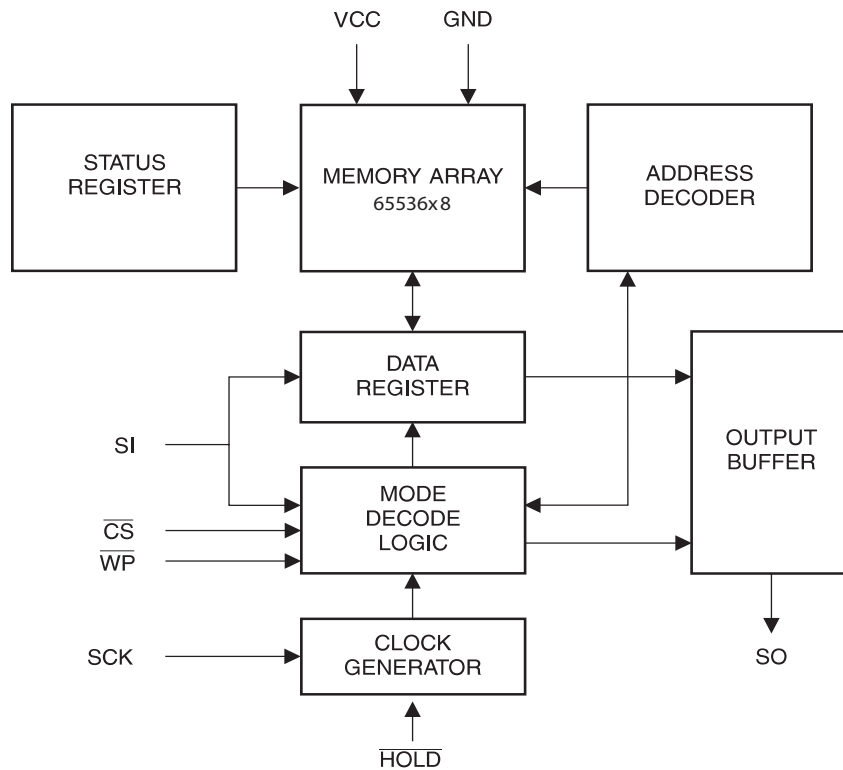

Table 2. Pin Capacitance<sup>(1)</sup>

Applicable over recommended operating range from T<sub>A</sub> = 25°C, f = 1.0 MHz, V<sub>CC</sub> = +3.6V (unless otherwise noted)

Symbol	Test Conditions	Max	Units	Conditions
C <sub>OUT</sub>	Output Capacitance (SO)	8	pF	V <sub>OUT</sub> = 0V
C <sub>IN</sub>	Input Capacitance (CS, SCK, SI, WP, HOLD)	6	pF	V <sub>IN</sub> = 0V

Note: 1. This parameter is characterized and is not 100% tested.

**Table 3.** DC Characteristics

Applicable over recommended operating range from  $T_{AI} = -40^{\circ}\text{C}$  to  $+85^{\circ}\text{C}$ ,  $V_{CC} = +1.8\text{V}$  to  $+3.6\text{V}$ ,  $V_{CC} = +1.8\text{V}$  to  $+3.6\text{V}$ (unless otherwise noted)

Symbol	Parameter	Test Condition	Min	Typ	Max	Units
$V_{CC1}$	Supply Voltage		1.8		3.6	V
$I_{CC1}$	Supply Current	$V_{CC} = 3.6\text{V}$ at 10 MHz, SO = Open, Read, Write		5.0	7.0	mA
$I_{CC2}$	Supply Current	$V_{CC} = 3.6\text{V}$ at 1 MHz, SO = Open, Read, Write		2.2	3.5	mA
$I_{SB1}$	Standby Current	$V_{CC} = 1.8\text{V}$ , $\overline{CS} = V_{CC}$		0.2	3.0	$\mu\text{A}$
$I_{SB2}$	Standby Current	$V_{CC} = 2.7\text{V}$ , $\overline{CS} = V_{CC}$		0.5	3.0	$\mu\text{A}$
$I_{SB3}$	Standby Current	$V_{CC} = 3.6\text{V}$ , $\overline{CS} = V_{CC}$		2.0	5.0	$\mu\text{A}$
$I_{IL}$	Input Leakage	$V_{IN} = 0\text{V}$ to $V_{CC}$	-3.0		3.0	$\mu\text{A}$
$I_{OL}$	Output Leakage	$V_{IN} = 0\text{V}$ to $V_{CC}$ , $T_{AC} = 0^{\circ}\text{C}$ to $70^{\circ}\text{C}$	-3.0		3.0	$\mu\text{A}$
$V_{IL}^{(1)}$	Input Low-voltage		-1.0		$V_{CC} \times 0.3$	V
$V_{IH}^{(1)}$	Input High-voltage		$V_{CC} \times 0.7$		$V_{CC} + 0.5$	V
$V_{OL1}$	Output Low-voltage	$1.8\text{V} \leq V_{CC} \leq 3.6\text{V}$			0.2	V
$V_{OH1}$	Output High-voltage			$I_{OL} = 0.15\text{ mA}$		V
			$I_{OH} = -100\ \mu\text{A}$	$V_{CC} - 0.2$		V

Note: 1.  $V_{IL}$  min and  $V_{IH}$  max are reference only and are not tested.

**Table 4.** AC Characteristics

Applicable over recommended operating range from  $T_{AI} = -40^{\circ}\text{C}$  to  $+85^{\circ}\text{C}$ ,  $V_{CC} = \text{As Specified}$ ,  $CL = 1\text{ TTL Gate}$  and  $30\text{ pF}$  (unless otherwise noted)

Symbol	Parameter	Voltage	Min	Max	Units
$f_{SCK}$	SCK Clock Frequency	2.7-3.6 1.8-3.6	0 0	10 5	MHz
$t_{RI}$	Input Rise Time	2.7-3.6 1.8-3.6		2 2	$\mu\text{s}$
$t_{FI}$	Input Fall Time	2.7-3.6 1.8-3.6		2 2	$\mu\text{s}$
$t_{WH}$	SCK High Time	2.7-3.6 1.8-3.6	40 80		ns
$t_{WL}$	SCK Low Time	2.7-3.6 1.8-3.6	40 80		ns
$t_{CS}$	$\overline{CS}$ High Time	2.7-3.6 1.8-3.6	100 200		ns
$t_{CSS}$	$\overline{CS}$ Setup Time	2.7-3.6 1.8-3.6	100 200		ns
$t_{CSH}$	$\overline{CS}$ Hold Time	2.7-3.6 1.8-3.6	100 200		ns
$t_{SU}$	Data In Setup Time	2.7-3.6 1.8-3.6	10 20		ns

**Table 4.** AC Characteristics (Continued)

Applicable over recommended operating range from  $T_{AI} = -40^{\circ}\text{C}$  to  $+85^{\circ}\text{C}$ ,  $V_{CC} = \text{As Specified}$ ,  $CL = 1 \text{ TTL Gate and } 30 \text{ pF}$  (unless otherwise noted)

Symbol	Parameter	Voltage	Min	Max	Units
$t_H$	Data In Hold Time	2.7–3.6 1.8–3.6	10 20		ns
$t_{HD}$	$\overline{\text{Hold}}$ Setup Time	2.7–3.6 1.8–3.6	10 20		ns
$t_{CD}$	$\overline{\text{Hold}}$ Hold Time	2.7–3.6 1.8–3.6	10 20		ns
$t_V$	Output Valid	2.7–3.6 1.8–3.6	0 0	40 80	ns
$t_{HO}$	Output Hold Time	2.7–3.6 1.8–3.6	0 0		ns
$t_{LZ}$	$\overline{\text{Hold}}$ to Output Low Z	2.7–3.6 1.8–3.6	0 0	50 100	ns
$t_{HZ}$	$\overline{\text{Hold}}$ to Output High Z	2.7–3.6 1.8–3.6		50 100	ns
$t_{DIS}$	Output Disable Time	2.7–3.6 1.8–3.6		50 100	ns
$t_{WC}$	Write Cycle Time	2.7–3.6 1.8–3.6		5 5	ms
Endurance <sup>(1)</sup>	3.3V, 25°C, Page Mode		1M		Write Cycles

Note: 1. This parameter is ensured by characterization only.

## Serial Interface Description

**MASTER:** The device that generates the serial clock.

**SLAVE:** Because the serial clock pin (SCK) is always an input, the AT25512 always operates as a slave.

**TRANSMITTER/RECEIVER:** The AT25512 has separate pins designated for data transmission (SO) and reception (SI).

**MSB:** The Most Significant Bit (MSB) is the first bit transmitted and received.

**SERIAL OP-CODE:** After the device is selected with  $\overline{\text{CS}}$  going low, the first byte will be received. This byte contains the op-code that defines the operations to be performed.

**INVALID OP-CODE:** If an invalid op-code is received, no data will be shifted into the AT25512, and the serial output pin (SO) will remain in a high impedance state until the falling edge of  $\overline{\text{CS}}$  is detected again. This will reinitialize the serial communication.

**CHIP SELECT:** The AT25512 is selected when the  $\overline{\text{CS}}$  pin is low. When the device is not selected, data will not be accepted via the SI pin, and the serial output pin (SO) will remain in a high impedance state.

**HOLD:** The  $\overline{\text{HOLD}}$  pin is used in conjunction with the  $\overline{\text{CS}}$  pin to select the AT25512. When the device is selected and a serial sequence is underway,  $\overline{\text{HOLD}}$  can be used to pause the serial communication with the master device without resetting the serial sequence. To pause, the  $\overline{\text{HOLD}}$  pin must be brought low while the SCK pin is low. To resume serial communication, the  $\overline{\text{HOLD}}$  pin is brought high while the SCK pin is low (SCK may still toggle during HOLD). Inputs to the SI pin will be ignored while the SO pin is in the high impedance state.

**WRITE PROTECT:** The write protect pin ( $\overline{WP}$ ) will allow normal read/write operations when held high. When the  $\overline{WP}$  pin is brought low and  $WPEN$  bit is "1", all write operations to the status register are inhibited.  $\overline{WP}$  going low while  $\overline{CS}$  is still low will interrupt a write to the status register. If the internal write cycle has already been initiated,  $\overline{WP}$  going low will have no effect on any write operation to the status register. The  $\overline{WP}$  pin function is blocked when the  $WPEN$  bit in the status register is "0". This will allow the user to install the AT25512 in a system with the  $\overline{WP}$  pin tied to ground and still be able to write to the status register. All  $\overline{WP}$  pin functions are enabled when the  $WPEN$  bit is set to "1".

Figure 2. SPI Serial Interface

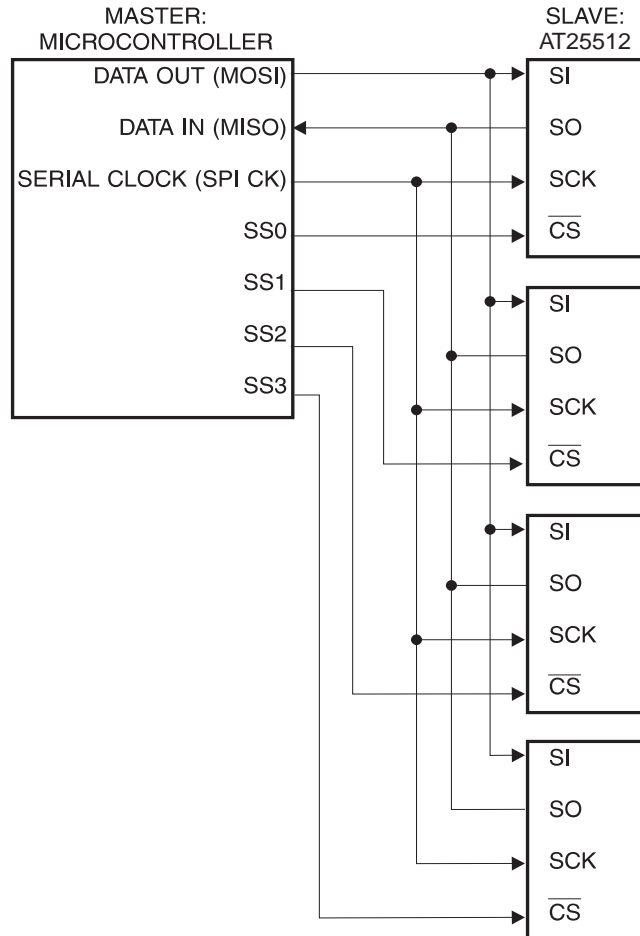



## Functional Description

The AT25512 is designed to interface directly with the synchronous serial peripheral interface (SPI) of the 6800 type series of microcontrollers.

The AT25512 utilizes an 8-bit instruction register. The list of instructions and their operation codes are contained in see Table 5. All instructions, addresses, and data are transferred with the MSB first and start with a high-to-low  $\overline{CS}$  transition.

**Table 5.** Instruction Set for the AT25512

Instruction Name	Instruction Format	Operation
WREN	0000 X110	Set Write Enable Latch
WRDI	0000 X100	Reset Write Enable Latch
RDSR	0000 X101	Read Status Register
WRSR	0000 X001	Write Status Register
READ	0000 X011	Read Data from Memory Array
WRITE	0000 X010	Write Data to Memory Array

**WRITE ENABLE (WREN):** The device will power-up in the write disable state when  $V_{CC}$  is applied. All programming instructions must therefore be preceded by a Write Enable instruction.

**WRITE DISABLE (WRDI):** To protect the device against inadvertent writes, the Write Disable instruction disables all programming modes. The WRDI instruction is independent of the status of the  $\overline{WP}$  pin.

**READ STATUS REGISTER (RDSR):** The Read Status Register instruction provides access to the status register. The Ready/Busy and Write Enable status of the device can be determined by the RDSR instruction. Similarly, the Block Write Protection bits indicate the extent of protection employed. These bits are set by using the WRSR instruction.

**Table 6.** Status Register Format

Bit 7	Bit 6	Bit 5	Bit 4	Bit 3	Bit 2	Bit 1	Bit 0
WPEN	X	X	X	BP1	BP0	WEN	$\overline{RDY}$

**Table 7.** Read Status Register Bit Definition

Bit	Definition
Bit 0 ( $\overline{RDY}$ )	Bit 0 = "0" ( $\overline{RDY}$ ) indicates the device is ready. Bit 0 = "1" indicates the write cycle is in progress.
Bit 1 (WEN)	Bit 1 = 0 indicates the device <i>is not</i> write enabled. Bit 1 = "1" indicates the device is write enabled.
Bit 2 (BP0)	See Table 8 on page 7.
Bit 3 (BP1)	See Table 8 on page 7.
Bits 4 – 6 are 0s when device is not in an internal write cycle.	
Bit 7 (WPEN)	See Table 9 on page 7.
Bits 0 – 7 are "1"s during an internal write cycle.	

**WRITE STATUS REGISTER (WRSR):** The WRSR instruction allows the user to select one of four levels of protection. The AT25512 is divided into four array segments. Top quarter (1/4), top half (1/2), or all of the memory segments can be protected. Any of the data within any selected segment will therefore be read only. The block write protection levels and corresponding status register control bits are shown in Table 8.

The three bits, BP0, BP1, and WPEN are nonvolatile cells that have the same properties and functions as the regular memory cells (e.g. WREN,  $t_{WC}$ , RDSR).

**Table 8.** Block Write Protect Bits

Level	Status Register Bits		Array Addresses Protected
	BP1	BP0	AT25512
0	0	0	None
1(1/4)	0	1	C000 - FFFF
2(1/2)	1	0	8000 – FFFF
3(All)	1	1	0000 – FFFF

The WRSR instruction also allows the user to enable or disable the write protect ( $\overline{WP}$ ) pin through the use of the write protect enable (WPEN) bit. Hardware write protection is enabled when the  $\overline{WP}$  pin is low and the WPEN bit is “1”. Hardware write protection is disabled when *either* the  $\overline{WP}$  pin is high or the WPEN bit is “0”. When the device is hardware write protected, writes to the Status Register, including the Block Protect bits and the WPEN bit, and the block-protected sections in the memory array are disabled. Writes are only allowed to sections of the memory which are not block-protected.

**NOTE:** When the WPEN bit is hardware write protected, it cannot be changed back to “0”, as long as the  $\overline{WP}$  pin is held low.

**Table 9.** WPEN Operation

WPEN	WP	WEN	Protected Blocks	Unprotected Blocks	Status Register
0	X	0	Protected	Protected	Protected
0	X	1	Protected	Writable	Writable
1	Low	0	Protected	Protected	Protected
1	Low	1	Protected	Writable	Protected
X	High	0	Protected	Protected	Protected
X	High	1	Protected	Writable	Writable

**READ SEQUENCE (READ):** Reading the AT25512 via the SO pin requires the following sequence. After the CS line is pulled low to select a device, the Read op-code is transmitted via the SI line followed by the byte address to be read (see Table 10 on page 8). Upon completion, any data on the SI line will be ignored. The data (D7 - D0) at the specified address is then shifted out onto the SO line. If only one byte is to be read, the CS line should be driven high after the data comes out. The read sequence can be continued since the byte address is automatically incremented and data will continue to be shifted out. When the highest address is reached, the address counter will roll over to the lowest address allowing the entire memory to be read in one continuous read cycle.



**WRITE SEQUENCE (WRITE):** In order to program the AT25512, two separate instructions must be executed. First, the device *must be write enabled* via the Write Enable (WREN) Instruction. Then a Write instruction may be executed. Also, the address of the memory location(s) to be programmed must be outside the protected address field location selected by the Block Write Protection Level. During an internal write cycle, all commands will be ignored except the RDSR instruction.

A Write Instruction requires the following sequence. After the  $\overline{CS}$  line is pulled low to select the device, the Write op-code is transmitted via the SI line followed by the byte address and the data (D7 - D0) to be programmed (see Table 10). Programming will start after the  $\overline{CS}$  pin is brought high. (The Low-to-High transition of the  $\overline{CS}$  pin must occur during the SCK low time immediately after clocking in the D0 (LSB) data bit.

The Ready/Busy status of the device can be determined by initiating a Read Status Register (RDSR) Instruction. If Bit 0 = 1, the Write cycle is still in progress. If Bit 0 = 0, the Write cycle has ended. Only the Read Status Register instruction is enabled during the Write programming cycle.

The AT25512 is capable of a 128-byte Page Write operation. After each byte of data is received, the six low order address bits are internally incremented by one; the high order bits of the address will remain constant. If more than 128 bytes of data are transmitted, the address counter will roll over and the previously written data will be overwritten. The AT25512 is automatically returned to the write disable state at the completion of a Write cycle.

**NOTE:** If the device is not write enabled (WREN), the device will ignore the Write instruction and will return to the standby state, when  $\overline{CS}$  is brought high. A new  $\overline{CS}$  falling edge is required to re-initiate the serial communication.

**Table 10.** Address Key

Address	AT25512
$A_N$	$A_{15} - A_0$



### Timing Diagrams (for SPI Mode 0 (0, 0))

Figure 3. Synchronous Data Timing

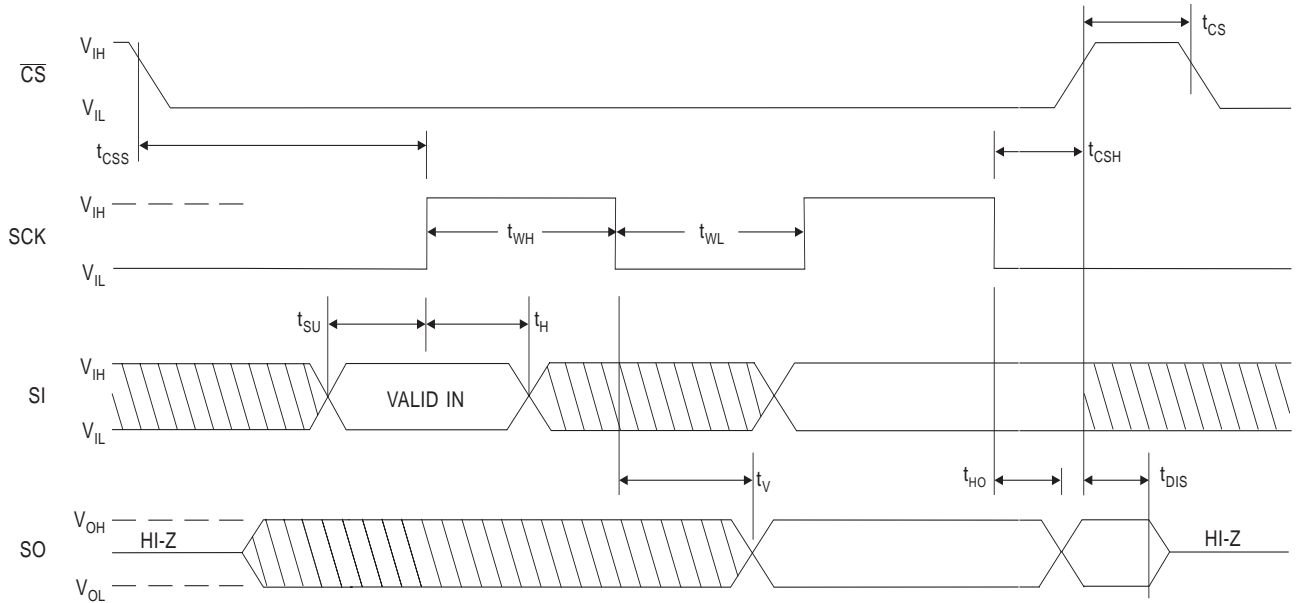
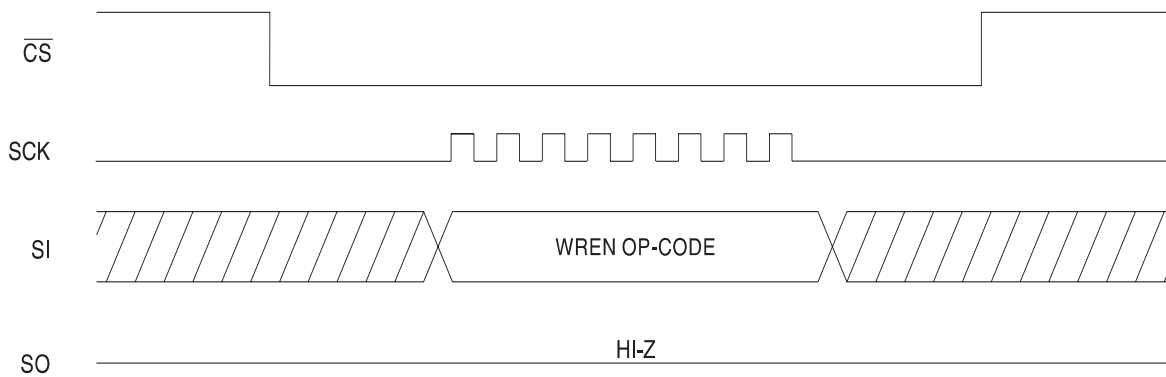
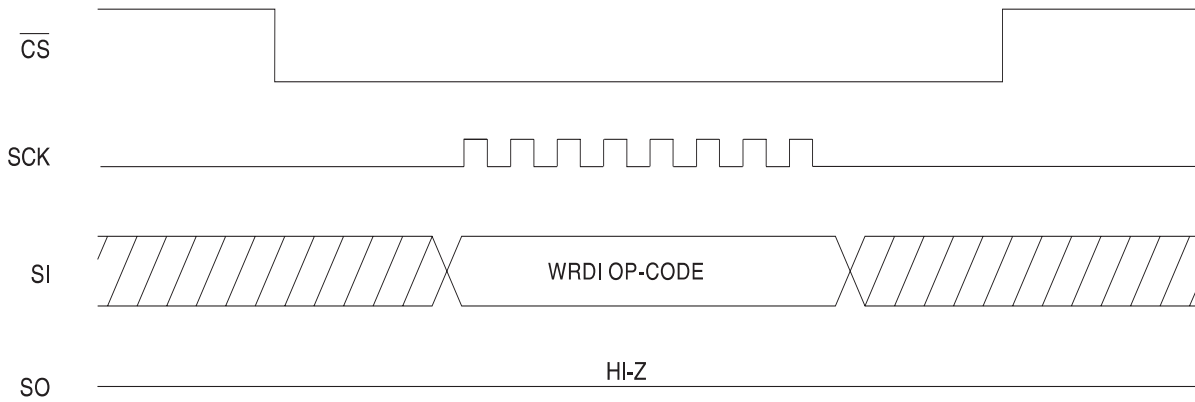

Figure 4. WREN Timing



**Figure 5. WRDI Timing**



**Figure 6. RDSR Timing**

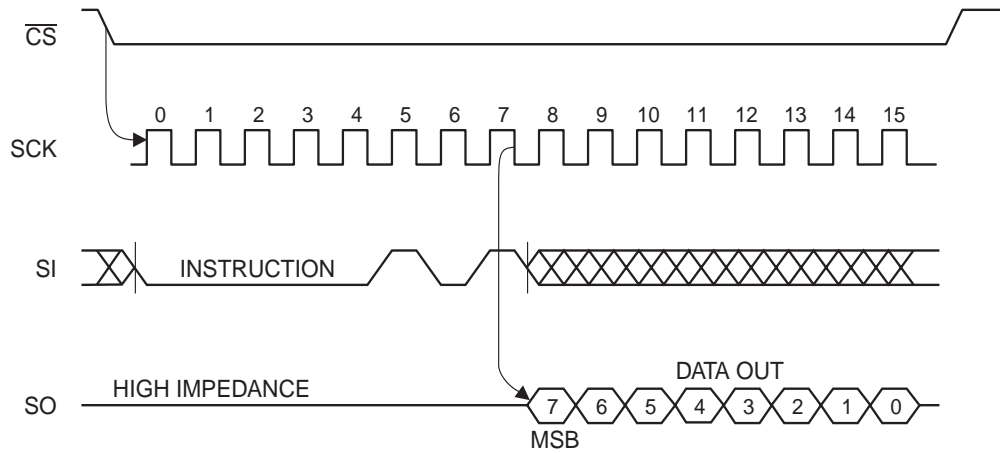

**Figure 7. WRSR Timing**

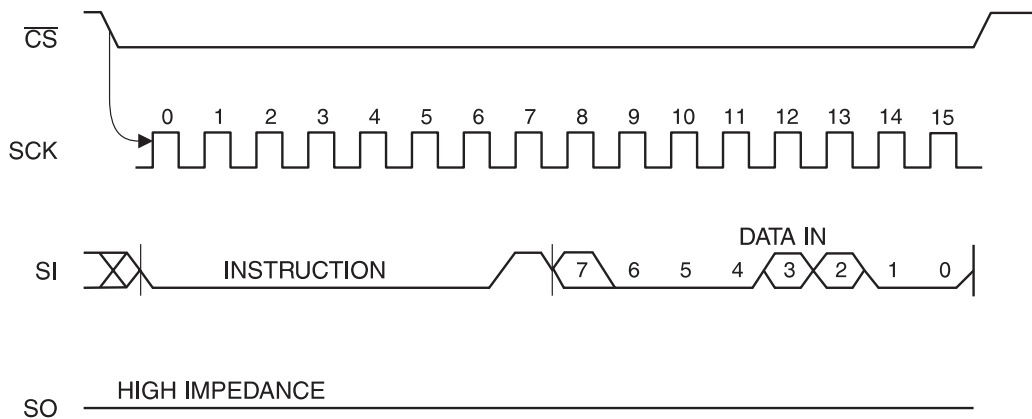

Figure 8. READ Timing

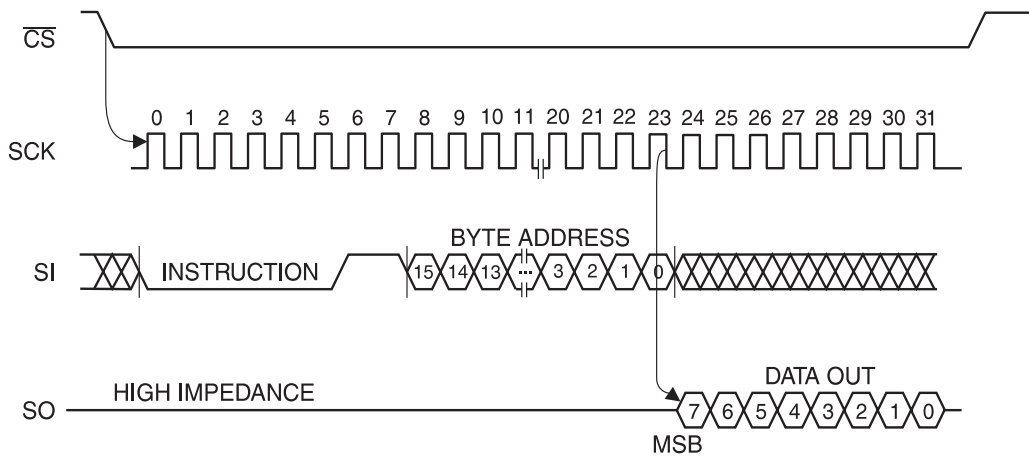

Figure 9. WRITE Timing

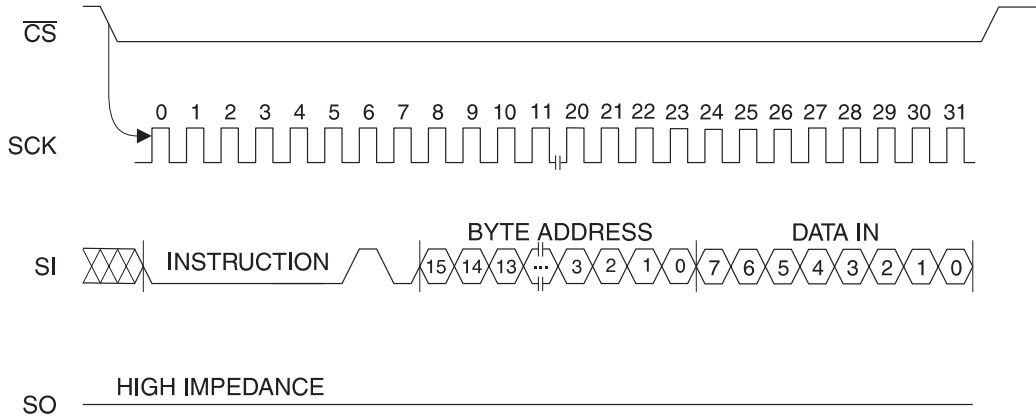
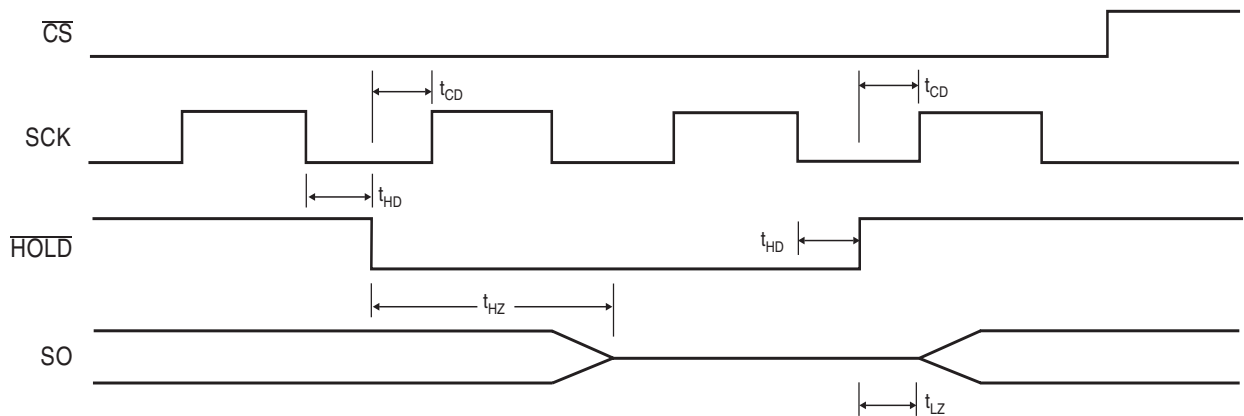

Figure 10. HOLD Timing





## AT25512 Ordering Information

Ordering Code	Voltage	Package	Operation Range
AT25512N-SH-B <sup>(1)</sup>	1.8	8S1	Lead-free/Halogen-free NiPDau Lead Finish Industrial Temperature (-40°C to 85°C)
AT25512N-SH-T <sup>(2)</sup>	1.8	8S1	
AT25512-TH-B <sup>(1)</sup>	1.8	8A2	
AT25512-TH-T <sup>(2)</sup>	1.8	8A2	
AT25512Y7-YH-T <sup>(2)</sup>	1.8	8Y7	
AT25512-W-11 <sup>(3)</sup>	1.8	Die Sale	Industrial Temperature (-40°C to 85°C)

- Notes:
1. "-B" denotes bulk.
  2. "-T" denotes tape and reel. SOIC = 4K per reel. TSSOP = 5K per reel. SAP = 3K per reel.
  3. Available in waffle pack, tape and reel, and wafer form; order as SL788 for inkless wafer form. Bumped die available upon request. Please contact Serial Interface Marketing.

Package Type	
<b>8S1</b>	8-lead, 0.150" Wide, Plastic Gull Wing Small Outline (JEDEC SOIC)
<b>8A2</b>	8-lead, 4.4 mm Body, Plastic Thin Shrink Small Outline Package (TSSOP)
<b>8Y7</b>	8-lead, 6.00mm x 4.90mm Body, Ultra Thin, Dual Footprint, Non-leaded, Small Array Package (SAP)
Options	
<b>-1.8</b>	Low-voltage (1.8V to 3.6V)

Packaging Information

8S1 – JEDEC SOIC

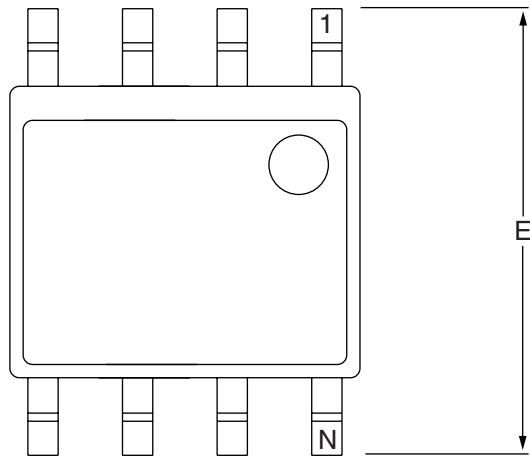

Top View

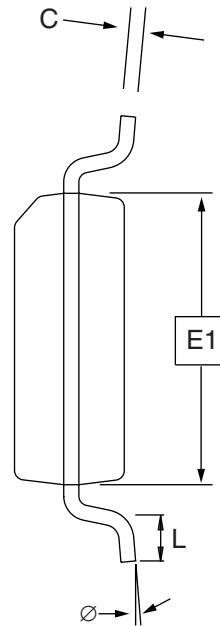

End View

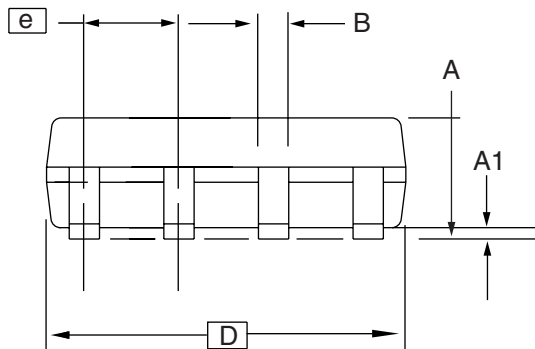

Side View

COMMON DIMENSIONS  
(Unit of Measure = mm)

SYMBOL	MIN	NOM	MAX	NOTE
A	1.35	–	1.75	
A1	0.10	–	0.25	
b	0.31	–	0.51	
C	0.17	–	0.25	
D	4.80	–	5.00	
E1	3.81	–	3.99	
E	5.79	–	6.20	
e	1.27 BSC			
L	0.40	–	1.27	
∅	0°	–	8°	

Note: These drawings are for general information only. Refer to JEDEC Drawing MS-012, Variation AA for proper dimensions, tolerances, datums, etc.

10/7/03



1150 E. Cheyenne Mtn. Blvd.  
Colorado Springs, CO 80906

**TITLE**  
8S1, 8-lead (0.150" Wide Body), Plastic Gull Wing  
Small Outline (JEDEC SOIC)

**DRAWING NO.**  
8S1

**REV.**  
B



# 8A2 – TSSOP

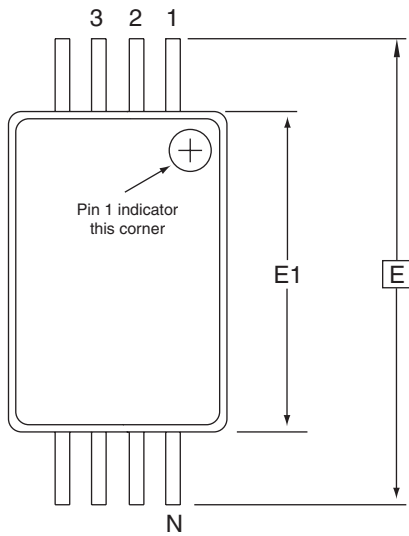

Top View

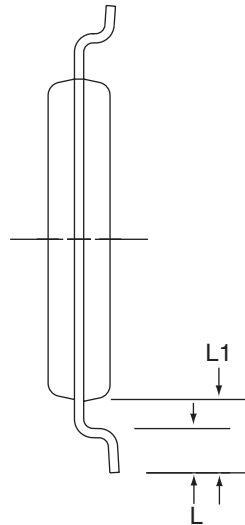

End View

**COMMON DIMENSIONS**  
(Unit of Measure = mm)

SYMBOL	MIN	NOM	MAX	NOTE
D	2.90	3.00	3.10	2, 5
E	6.40 BSC			
E1	4.30	4.40	4.50	3, 5
A	-	-	1.20	
A2	0.80	1.00	1.05	
b	0.19	-	0.30	4
e	0.65 BSC			
L	0.45	0.60	0.75	
L1	1.00 REF			

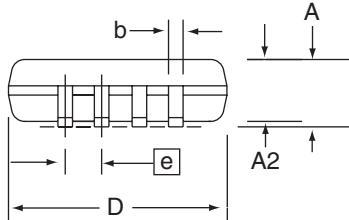

Side View

- Notes:
1. This drawing is for general information only. Refer to JEDEC Drawing MO-153, Variation AA, for proper dimensions, tolerances, datums, etc.
  2. Dimension D does not include mold Flash, protrusions or gate burrs. Mold Flash, protrusions and gate burrs shall not exceed 0.15 mm (0.006 in) per side.
  3. Dimension E1 does not include inter-lead Flash or protrusions. Inter-lead Flash and protrusions shall not exceed 0.25 mm (0.010 in) per side.
  4. Dimension b does not include Dambar protrusion. Allowable Dambar protrusion shall be 0.08 mm total in excess of the b dimension at maximum material condition. Dambar cannot be located on the lower radius of the foot. Minimum space between protrusion and adjacent lead is 0.07 mm.
  5. Dimension D and E1 to be determined at Datum Plane H.

5/30/02



2325 Orchard Parkway  
San Jose, CA 95131

**TITLE**  
**8A2**, 8-lead, 4.4 mm Body, Plastic  
Thin Shrink Small Outline Package (TSSOP)

**DRAWING NO.**  
8A2

**REV.**  
B

8Y7 - SAP

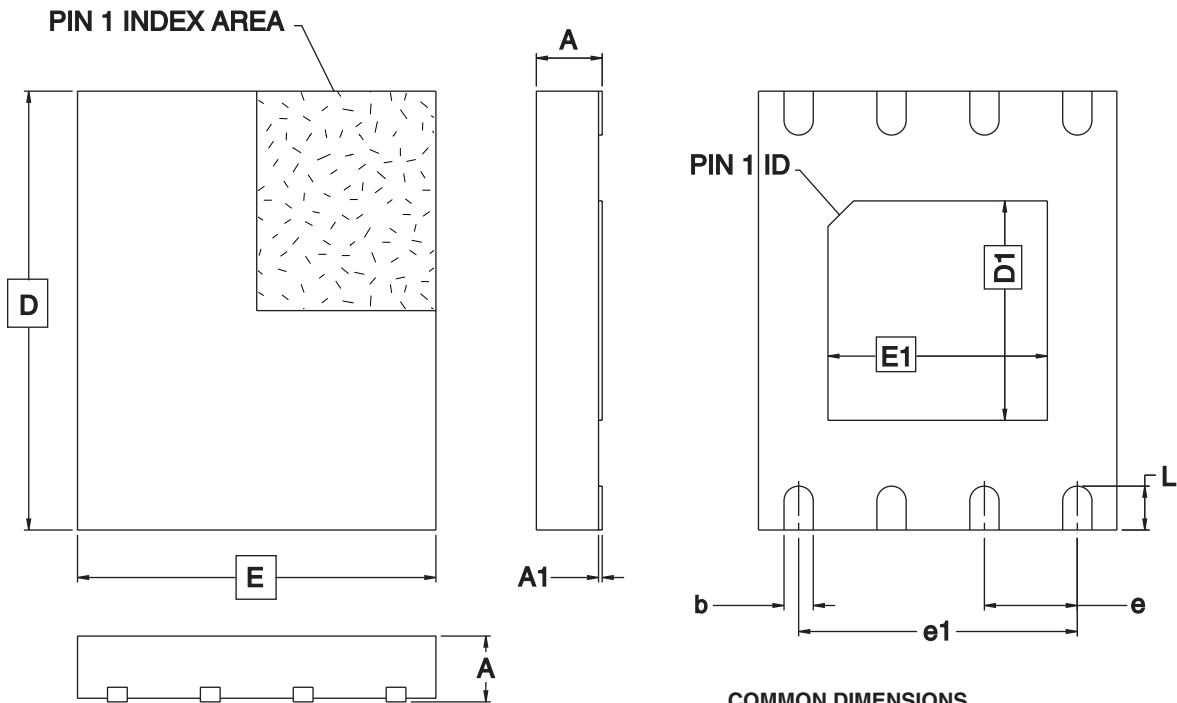

COMMON DIMENSIONS  
(Unit of Measure = mm)

SYMBOL	MIN	NOM	MAX	NOTE
A	-	-	0.60	
A1	0.00	-	0.05	
D	5.80	6.00	6.20	
E	4.70	4.90	5.10	
D1	3.30	3.40	3.50	
E1	3.90	4.00	4.10	
b	0.35	0.40	0.45	
e	1.27 TYP			
e1	3.81 REF			
L	0.50	0.60	0.70	

10/13/05



1150 E. Cheyenne Mtn. Blvd.  
Colorado Springs, CO 80906

TITLE

8Y7, 8-lead (6.00 x 4.90 mm Body) Ultra-Thin SOIC Array  
Package (UTSAP) Y7

DRAWING NO.

8Y7

REV.

B





## Revision History

Doc. Rev.	Date	Comments
5165A	1/2007	Initial document release.





## Atmel Corporation

2325 Orchard Parkway  
San Jose, CA 95131, USA  
Tel: 1(408) 441-0311  
Fax: 1(408) 487-2600

## Regional Headquarters

### Europe

Atmel Sarl  
Route des Arsenalux 41  
Case Postale 80  
CH-1705 Fribourg  
Switzerland  
Tel: (41) 26-426-5555  
Fax: (41) 26-426-5500

### Asia

Room 1219  
Chinachem Golden Plaza  
77 Mody Road Tsimshatsui  
East Kowloon  
Hong Kong  
Tel: (852) 2721-9778  
Fax: (852) 2722-1369

### Japan

9F, Tonetsu Shinkawa Bldg.  
1-24-8 Shinkawa  
Chuo-ku, Tokyo 104-0033  
Japan  
Tel: (81) 3-3523-3551  
Fax: (81) 3-3523-7581

## Atmel Operations

### Memory

2325 Orchard Parkway  
San Jose, CA 95131, USA  
Tel: 1(408) 441-0311  
Fax: 1(408) 436-4314

### Microcontrollers

2325 Orchard Parkway  
San Jose, CA 95131, USA  
Tel: 1(408) 441-0311  
Fax: 1(408) 436-4314

La Chantrerie  
BP 70602  
44306 Nantes Cedex 3, France  
Tel: (33) 2-40-18-18-18  
Fax: (33) 2-40-18-19-60

### ASIC/ASSP/Smart Cards

Zone Industrielle  
13106 Rousset Cedex, France  
Tel: (33) 4-42-53-60-00  
Fax: (33) 4-42-53-60-01

1150 East Cheyenne Mtn. Blvd.  
Colorado Springs, CO 80906, USA  
Tel: 1(719) 576-3300  
Fax: 1(719) 540-1759

Scottish Enterprise Technology Park  
Maxwell Building  
East Kilbride G75 0QR, Scotland  
Tel: (44) 1355-803-000  
Fax: (44) 1355-242-743

### RF/Automotive

Theresienstrasse 2  
Postfach 3535  
74025 Heilbronn, Germany  
Tel: (49) 71-31-67-0  
Fax: (49) 71-31-67-2340

1150 East Cheyenne Mtn. Blvd.  
Colorado Springs, CO 80906, USA  
Tel: 1(719) 576-3300  
Fax: 1(719) 540-1759

### Biometrics/Imaging/Hi-Rel MPU/ High Speed Converters/RF Datacom

Avenue de Rochepleine  
BP 123  
38521 Saint-Egreve Cedex, France  
Tel: (33) 4-76-58-30-00  
Fax: (33) 4-76-58-34-80

---

### Literature Requests

[www.atmel.com/literature](http://www.atmel.com/literature)

**Disclaimer:** The information in this document is provided in connection with Atmel products. No license, express or implied, by estoppel or otherwise, to any intellectual property right is granted by this document or in connection with the sale of Atmel products. **EXCEPT AS SET FORTH IN ATMEL'S TERMS AND CONDITIONS OF SALE LOCATED ON ATMEL'S WEB SITE, ATMEL ASSUMES NO LIABILITY WHATSOEVER AND DISCLAIMS ANY EXPRESS, IMPLIED OR STATUTORY WARRANTY RELATING TO ITS PRODUCTS INCLUDING, BUT NOT LIMITED TO, THE IMPLIED WARRANTY OF MERCHANTABILITY, FITNESS FOR A PARTICULAR PURPOSE, OR NON-INFRINGEMENT. IN NO EVENT SHALL ATMEL BE LIABLE FOR ANY DIRECT, INDIRECT, CONSEQUENTIAL, PUNITIVE, SPECIAL OR INCIDENTAL DAMAGES (INCLUDING, WITHOUT LIMITATION, DAMAGES FOR LOSS OF PROFITS, BUSINESS INTERRUPTION, OR LOSS OF INFORMATION) ARISING OUT OF THE USE OR INABILITY TO USE THIS DOCUMENT, EVEN IF ATMEL HAS BEEN ADVISED OF THE POSSIBILITY OF SUCH DAMAGES.** Atmel makes no representations or warranties with respect to the accuracy or completeness of the contents of this document and reserves the right to make changes to specifications and product descriptions at any time without notice. Atmel does not make any commitment to update the information contained herein. Unless specifically provided otherwise, Atmel products are not suitable for, and shall not be used in, automotive applications. Atmel's products are not intended, authorized, or warranted for use as components in applications intended to support or sustain life.

© 2007 Atmel Corporation. **All rights reserved.** Atmel®, logo and combinations thereof, Everywhere You Are® and others, are registered trademarks or trademarks of Atmel Corporation or its subsidiaries. Other terms and product names may be trademarks of others.



Printed on recycled paper.

5165A-SEEPR-1/07