

AN75

High Power Factor LED Replacement T8 Fluorescent Tube using the AL9910 High Voltage LED Controller

Yong Ang, Diodes Inc.

Introduction

This application note describes the principles and design equations required for the design of a high brightness LED lamp using the AL9910. The equations are then used to demonstrate the design of a universal, offline, high power factor (PF), 13W LED lamp suitable for use as the replacement for T8 fluorescent tube. A complete design including the electrical diagram, component list and performance measurements are provided.

AL9910 high power factor buck LED driver

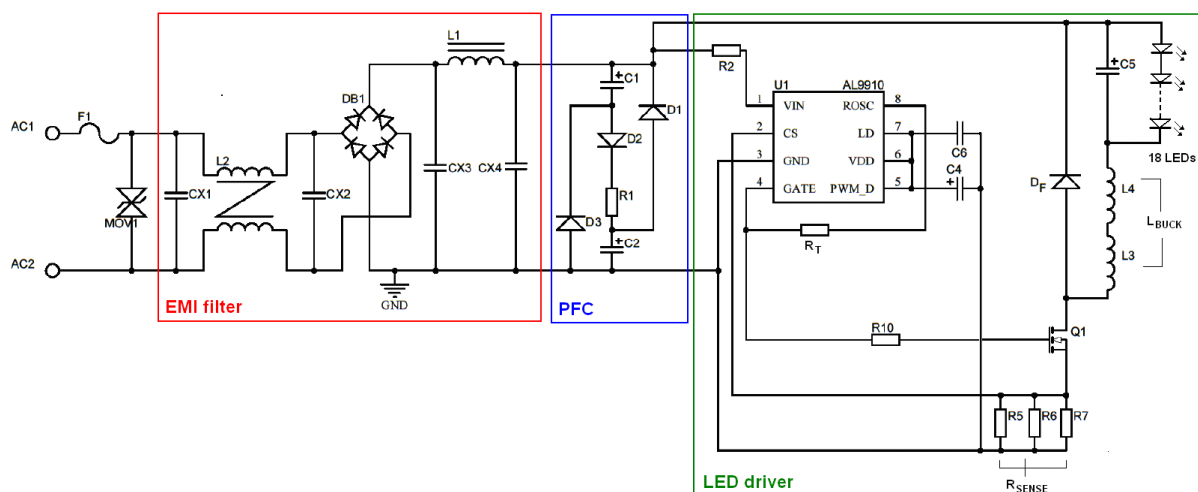

Figure 1 Electrical schematic of a high power factor 13W LED lamp

Figure 1 shows the electrical diagram of an offline 13W LED driver.

On the input side, CX1, CX2, CX3, CX4, L1 and L2 provide sufficient filtering for both differential mode and common mode EMI noise which are generated by the switching converter circuit.

The rectified AC line voltage from the bridge rectifier DB1 is then fed into a passive power factor correction or valley fill circuit which consists of 3 diodes and 2 capacitors. D1, D2, D3, C1, C2 improve the input line current distortion in order to achieve PF greater than 0.9 for the AC line input.

The constant current regulator section consists of a buck converter driven by the AL9910. Normally, the buck regulator is used in fixed frequency mode but its duty cycle limitation of 50% is not practical for offline lamp. This problem can be overcome by changing the control method to a fixed off-time operation.

The design of the internal oscillator in the AL9910 allows the IC to be configured for either fixed frequency or fixed off-time based on how resistor R_T is connected. For fixed off-time operation, the resistor R_T is connected between the Gate and R_{OSC} pins, as shown in Figure 1. This converter has now a constant off-time when the power MOSFET is turned off. The on-time is based on the current

sense signal and the switching adjusts to be the sum of the on- and off-time. This change allows the converter to work with duty cycles greater than 50%.

Design Guide – High power factor offline LED driver

In this section the design procedure is outlined according to the schematic shown in Figure 1. First, the guideline for selecting the components for valley fill power factor correction stage and fixed off-time buck converter is shown. The power inductor calculation is then demonstrated and finally, the power losses within MOSFET and free-wheel diode are assessed.

The specifications for the system are:

$$\begin{aligned} V_{AC} &= 230V_{ac} \\ V_{AC(min)} &= 85V_{ac} \\ V_{AC(max)} &= 264V_{ac} \\ I_{LED(nom)} &= 240mA \\ V_{LED(nom)} &= 54V \\ V_{LED(min)} &= 42V \\ V_{LED(max)} &= 59V \\ P_{OUT} &= 12.96W \\ f_{swi(nom)} &= 55kHz \end{aligned}$$

Passive factor correction stage design

The purpose of the valley fill circuit (see Figure 2) is to allow the buck converter to pull power directly off the AC line when the line voltage is greater than 50% of its peak voltage.

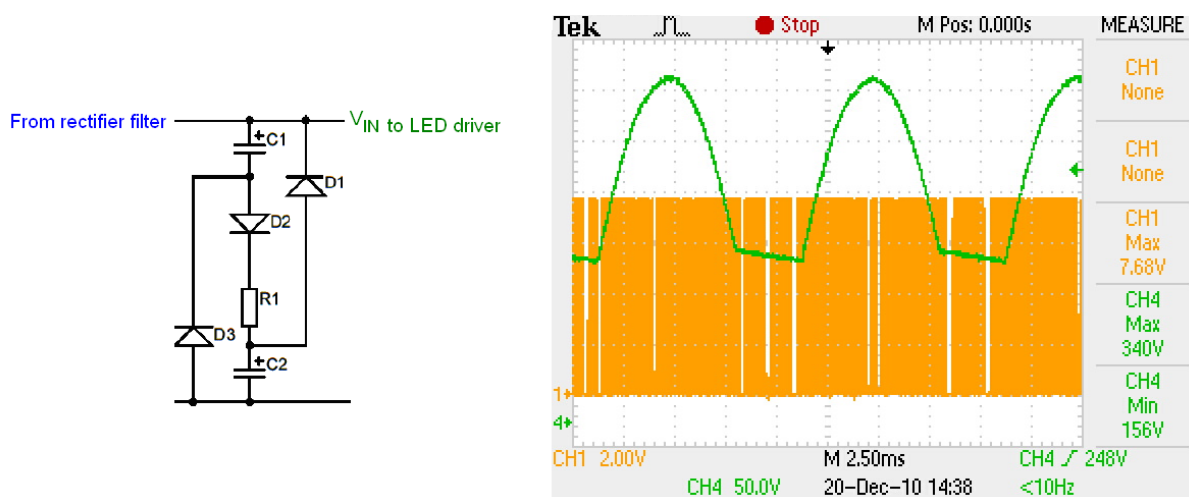

Figure 2 Valley-fill PFC stage and operating waveforms (Green: V_{IN} to LED driver; Orange: AL9910's gate voltage)

The maximum bus voltage at the input of the buck converter is,

$$V_{IN(max)} = \sqrt{2} \times V_{ac(max)} = \sqrt{2} \times 264V_{ac} = 373V$$

During this time, capacitors within the valley fill circuit (C1 and C2) are in series and charged via D2 and R1. If the capacitors have identical capacitance value, the peak voltage across C1 and C2

is $V_{IN(max)}/2 = 186V$. Often a 20% difference in capacitance could be observed between like capacitors. Therefore a voltage rating margin of 25% should be considered.

Once the line drops below 50% of its peak voltage, the two capacitors are essentially placed in parallel. The bus voltage $V_{IN(min)}$ is the lowest voltage value at the input of the buck converter. $V_{IN(min)}$ at the minimum AC line voltage $V_{ac(min)}$ is,

$$V_{IN(min)} = \sqrt{2} \times V_{ac(min)} / 2 = \sqrt{2} \times 85V_{ac} / 2 = 60V$$

At 60Hz, the total time of a half AC line cycle is 8.33ms. The power to the buck converter is derived from the valley-fill capacitors when the AC line voltage is equal to or less than 50% of its peak voltage. The hold up time for the capacitors equates to $t_{HOLD} = 1/3 \times 8.33ms = 2.77ms$. The valley-fill capacitor value can then be calculated,

$$C_{TOTAL} = \frac{P_{out} / V_{IN(min)} \times t_{HOLD}}{V_{DROOP}} = \frac{12.96W / 60V \times 2.77ms}{20V} = 30\mu F$$

Therefore, $C_1 = C_2 = 15\mu F$. V_{DROOP} is the voltage droop on the capacitors when they are delivering full power to the buck converter. Ideally V_{DROOP} should be set to less than $V_{DROOP} = V_{IN(min)} - V_{LED(max)}$ in order to ensure continuous LED conduction at low line voltage. Nevertheless, V_{DROOP} is set to be 20V in the design example to avoid the need for very large valley-fill electrolytic capacitor.

A 20V V_{DROOP} implies that the bus voltage V_{IN} at the input of buck converter will drop to 40V during part of the AC line cycle. As the buck regulator requires V_{IN} to be greater than the LED stack voltage ($V_{LED(max)} = 59V$) for regulation, the LED will be off during part of the AC line cycle. This has the effect of reducing the actual output LED current at low AC input voltage. In the design example, the LED current drops by approximately 20% from its nominal value at 85Vac (see Figure 4).

Setting the fixed off-time and switching frequency range

For fixed off-time operation, the switching frequency will vary subjected to the actual input voltage and output LED conditions.

A nominal switching frequency $f_{swi(nom)}$ should be chosen. A high nominal switching frequency will result in smaller inductor size, but could lead to increased switching losses in the circuit. A good design practice is to choose a nominal switching frequency knowing that the switching frequency will decrease as the line voltage drops and increases as the line voltage increases.

The fixed off-time t_{OFF} can be computed as,

$$t_{off} = \frac{1 - \frac{V_{LED(nom)}}{V_{ac(nom)}}}{f_{swi(nom)}} = \frac{1 - \frac{54V}{230V}}{55kHz} = 13.9\mu s$$

The off-time is programmed by timing resistor R_T as shown in Figure 1. The value of R_T is given by,

$$R_T(k\Omega) = t_{OFF}(\mu s) \times 25 - 22 = 13.9 \times 25 - 22 = 326k\Omega$$

A 330k Ω is selected for R_T . Next, the two extremes of the variable switching frequency can be approximated as,

$$f_{swi(min)} = \frac{1 - V_{LED(max)} / V_{IN(min)}}{t_{OFF}} = \frac{1 - 59V / 69V}{13.9\mu s} = 10kHz$$

$$f_{swi(max)} = \frac{1 - V_{LED(min)} / V_{IN(max)}}{t_{OFF}} = \frac{1 - 42V / 373V}{13.9\mu s} = 63.8kHz$$

It is advisable to keep below the maximum switching frequency $f_{\text{swi(max)}}$ below 150kHz to avoid excessive switching loss.

Inductor selection and setting the LED current

The fixed off-time architecture of the AL9910 regulates the average current through the inductor L_{BUCK} . The value of L_{BUCK} depends on the desirable peak-to-peak ripple ΔI_L in the output LED current. L_{BUCK} can be set with the following equation,

$$L_{\text{BUCK}} = \frac{V_{\text{LED(nom)}} \times t_{\text{OFF}}}{\Delta I_L} = \frac{54\text{V} \times 13.9\mu\text{s}}{115\text{mA}} = 6.6\text{mH}$$

Due to diameter limitation of the T8 tube, L_{BUCK} is made up of L3 and L4 as shown in Figure 1.

The AL9910 constant off-time control loop regulates the peak inductor current I_{pk} . As the average inductor current equals the average LED current, the average LED current can be regulated by controlling I_{pk} .

Given a fixed inductor value, the change in the inductor current over time is proportional to the voltage applied across the inductor. During the off-time, the voltage seen by the inductor is the LED stack voltage. So, the peak inductor current should be regulated to,

$$I_{\text{pk}} = I_{\text{LED(nom)}} + \frac{0.5 \times V_{\text{LED(nom)}} \times t_{\text{OFF}}}{L_{\text{BUCK}}} = 240\text{mA} + \frac{0.5 \times 54\text{V} \times 13.9\mu\text{s}}{6.6\text{mH}} = 297\text{mA}$$

The peak current is constant and set by the sense resistor R_{SENSE} . If the LD pin is tied to the VDD pin, the value of R_{SENSE} can be easily calculated because the voltage threshold on the CS pin is 0.25V,

$$R_{\text{SENSE}} = \frac{0.25}{297\text{mA}} = 0.84\Omega$$

In the circuit shown in Figure 1, R_{SENSE} consists of R5, R6 and R7.

The peak current rating of the L_{BUCK} should be greater than I_{pk} and the RMS current rating of the inductor should be at least 110% of $I_{\text{LED(nom)}}$.

Although the described solution, working in fixed off-time and Continuous Conduction Mode (CCM), works as a constant current source, a limitation to the output LED current accuracy is its dependency on the number of LEDs and overall LED chain voltage. The best result can be achieved using a fixed number of LEDs. A variable number of LEDs results in reduced current precision.

The two extremes of the output LED current can be approximated as,

$$I_{\text{LED(min)}} = I_{\text{pk}} - \frac{0.5 \times V_{\text{LED(max)}} \times t_{\text{OFF}}}{L_{\text{BUCK}}} = 297\text{mA} - \frac{0.5 \times 59\text{V} \times 13.9\mu\text{s}}{6.6\text{mH}} = 234\text{mA}$$

$$I_{\text{LED(max)}} = I_{\text{pk}} - \frac{0.5 \times V_{\text{LED(min)}} \times t_{\text{OFF}}}{L_{\text{BUCK}}} = 297\text{mA} - \frac{0.5 \times 42\text{V} \times 13.9\mu\text{s}}{6.6\text{mH}} = 253\text{mA}$$

The above equation shows that the precision of the LED current also depends on the tolerance of practical inductor L_{BUCK} . Inductor with tolerance rating equal or less than 10% should be chosen to ensure good LED current precision at mass production.

Power MOSFET calculation

The power MOSFET is chosen based on maximum voltage stress, peak MOSFET current, total power losses, maximum allowable working temperature and the gate driver capability of the AL9910.

Maximum drain-source voltage stress on the power MOSFET for this converter is equal to the input voltage. However, a typical voltage safety margin for the MOSFET defines the maximum reverse voltage as follows,

$$V_{DSS} = 1.3 \times V_{IN(max)} = 1.3 \times 373V = 485V$$

which implies that a common 500V MOSFET is suitable.

The power MOSFET losses will be dominated by switching loss. The switching loss depends on the switching time, frequency, MOSFET drain current and drain-source voltage. The switching rise time t_{RISE} and fall time t_{FALL} is a function of the MOSFET's gate capacitance, the gate driver capability of the AL9910 and layout design. The worst case switching power losses occurs at $V_{LED(min)}$ and $V_{IN(max)}$. The switching loss is approximately,

$$\begin{aligned} P_{SW} &= \frac{V_{IN(max)} \times \left(I_{pk} - \frac{V_{LED(min)} t_{OFF}}{L_{BUCK}} \right) \times t_{RISE} \times f_{swi(max)}}{2} + \frac{V_{IN(max)} \times I_{pk} \times t_{FALL} \times f_{swi(max)}}{2} \\ &= \frac{373V \times (297mA - 88mA) \times 65ns \times 63.8kHz}{2} + \frac{373V \times 65ns \times 63.8kHz}{2} \\ &= 455mW \end{aligned}$$

where the switching time t_{RISE} and t_{FALL} are measured to be 65ns with the 600V MOSFET SPB03N60S5 as the power MOSFET. As shown in Figure 1, R10 is a series gate resistor that slows down the MOSFET switching and reduces EMI emission.

The RMS current through the MOSFET at $V_{LED(min)}$ and $V_{IN(max)}$ is given by,

$$\begin{aligned} I_{D(RMS)} &= \sqrt{\frac{V_{LED(min)}}{V_{IN(max)}}} \times \left(I_{LED(nom)} + \frac{V_{LED(min)} \times t_{OFF} / L_{BUCK}}{\sqrt{12}} \right) \\ &= \sqrt{\frac{42V}{373V}} \times \left(240mA + \frac{42V \times 13.9\mu s / 6.6mH}{\sqrt{12}} \right) \\ &= 89mA \end{aligned}$$

The power MOSFET conduction loss depends on its static drain-source resistance $R_{DS(ON)}$ at the MOSFET working temperature. It is possible to calculate the continuous conduction loss:

$$P_{COND} = I_{D(RMS)}^2 \times R_{DS(ON)} = (89mA)^2 \times 2.5\Omega = 19mW$$

The total power MOSFET loss is:

$$P_{TOT} = P_{SW} + P_{COND} = 455mW + 19mW = 474mW$$

Total MOSFET power loss is dissipated from the SMD package into the PC Board. So it is possible to calculate the MOSFET working junction temperature can be calculated if the package junction-to-ambient thermal resistance R_{thJA} is known. The calculated MOSFET junction temperature, T_J , must be lower than the maximum allowable junction temperature $T_{J(MAX)}$:

$$T_J = P_{TOT} \times \theta_{thJA} + T_{AMB} = 474mW \times 62^\circ C/W + 80^\circ C = 109.4^\circ C$$

The internal ambient temperature within the LED converter, T_{AMB} , is assumed to be 80°C. $\theta_{thJA} = 62^\circ C/W$ is the thermal resistance for TO-263 with minimum copper area. For practical design, it is recommended to keep the junction temperature below 110°C to avoid temperature stress on the device.

Free-wheel diode calculation

The free-wheel diode D_F shown in Figure 1 is chosen based on its maximum stress voltage and total power loss. The maximum stress voltage rating of the free-wheel diode is the same as the MOSFET. It is advisable to use ultra-low reverse recovery time T_{RR} (<35ns) diode as D_F to reduce the MOSFET's switching ON loss. In the design example, 1A 600V rectifier, MUR160, is selected.

The worst case average current through the diode occurs at $V_{LED(max)}$ and $V_{IN(min)}$.

$$I_{D(avg)} = I_{LED(nom)} \times \left(1 - \frac{V_{LED(min)}}{V_{IN(max)}} \right) = 240mA \times \left(1 - \frac{42V}{373V} \right) = 202mA$$

Assuming a constant forward voltage drop V_F across the diode, the conduction power loss can be calculated,

$$P_{D_COND} = I_{D(avg)} \times V_F = 202mA \times 1.1V = 222mW$$

Finally, the diode junction temperature without using the heat sink can be calculated from,

$$T_j = P_{D_COND} \times \theta_{thJA} + T_{AMB} = 222mW \times 32^\circ C/W + 80^\circ C = 87^\circ C$$

The internal ambient temperature within the LED converter, T_{AMB} , is assumed to be 80°C. $\theta_{thJA} = 32^\circ C/W$ is the thermal resistance for DO-201 package. For practical design, it is recommended to keep the junction temperature below 110°C to avoid temperature stress on the device.

The BOM in table 1 and the PCB layout in Figure 2 complete the tools needed to design a high power factor LED driver using the AL9910. Figure 3 shows the picture of the completed LED driver designed with a footprint to fit inside the T8 LED Fluorescent replacement lamp tube.

Table 1 BOM

Ref.	Descriptions	Part number	Package	Mfr.
U1	Universal high brightness LED driver	AL9910	SO8	Diodes Inc.
D1, D2, D3	1A, 1kV diode $t_{RR} = 1.8\mu s$	S1M-13-F	SMA	Diodes Inc.
D4	Ultra-fast-recovery diode 1A, 600V, $t_{RR} = 35ns$	MUR160	DO201AD	Diodes Inc.
DB1	1A, 600V bridge rectifier	DF06S	DF-S	Diodes Inc.
C1, C2	15 μF , 450V electrolytic capacitor +/-20% 1000hrs @ 105°C	EEUED2W150 400KXW27M10X30 UCY2G150MPD	5mm pitch	Panasonic Rubicon Nichicon
C4	4.7 μF , 50V electrolytic capacitor +/-20% 1000hrs @ 105°C	ECE-A1HKG4R7	1.5mm pitch	Panasonic
C5	10 μF 450V electrolytic capacitor +/-20% 1000hrs @ 105°C, 10mm diameter	EEUEE2W100U	5mm pitch	Panasonic
CX1, CX2, CX3, CX4	100nF, 275VAC, Film, X2	ECQU2A104ML	17.5mm pitch	Panasonic
F1	100 Ω 1W fusible resistor +/-200ppm	NFR0100001009JR500	Through-hole axial	Vishay
L1	6.8mH inductor +/-10% 290mA radial	19R685C	5mm pitch	Murata
L2	30mH common-mode inductor, 8mm height	B82791G2301N001	10mm pitch	EPCOS
L3, L4	3.3mH inductor +/-10% 420mA radial	19R335C	6mm pitch	Murata
MOV1	275V, 21J, 9mm, Radial	B72207S0271K101	5mm pitch	EPCOS
Q1	N-ch MOSFET 600V, 3.2A, $Q_{g(max)} = 16nC$	SPB03N60S5	TO263	Infineon
R1	10R 3W wire wound resistor, 50ppm/°C, +/-1%	UB3C-10RF1	Through-hole axial	Riedon
R2	3k 0.25W resistor +/-5%	Any	1206	Any
R5	1R2 0.25W +/-1%	Any	1206	Any
R6	2R7 0.25W +/-1%	Any	1206	Any
R7	100R 0.25W +/-1%	Any	1206	Any
R _T	330k 0.125W resistor +/-1%	Any	1206	Any
R10	10R 0.25W +/-5%	Any	1206	Any

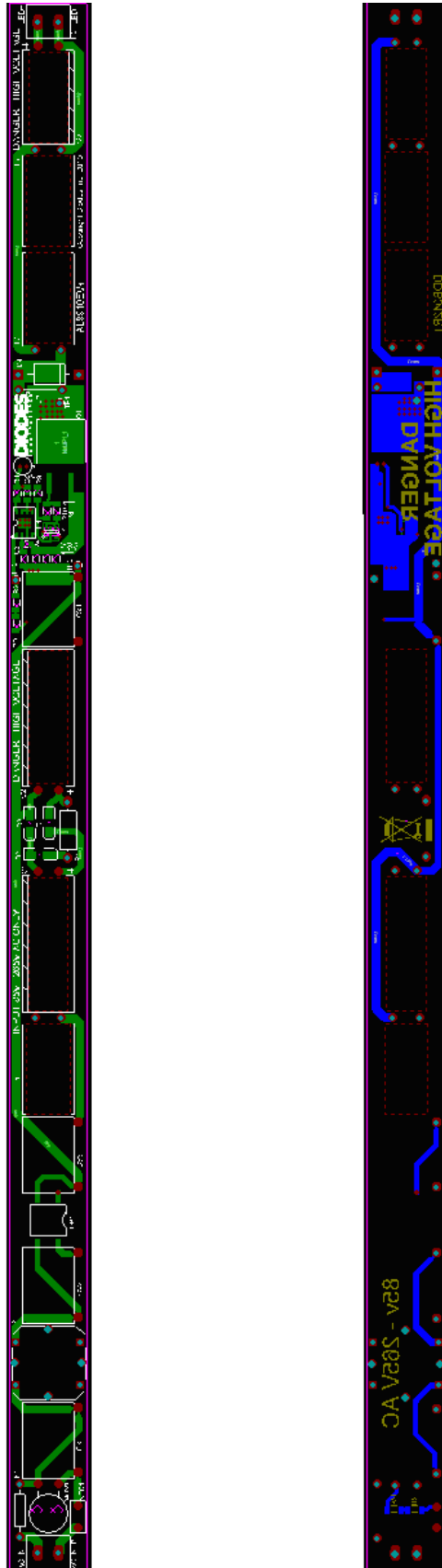

Figure 2 Top layer and bottom layer layout



Figure 3 Picture of the LED T8 Fluorescent replacement lamp driver

Results

The performance of the system is outlined in Figures 4, and 5.

They display a level of system efficiency higher than 87% when driving 18 LEDs. The system efficiency reduces with decreasing number of LEDs but 83% can still be achieved when driving 14 LEDs at 264Vac input.

When driving 18 LEDs, a current regulation of around 3% is achieved between the input voltages of 110Vac to 264Vac. The LED current drops to 190mA at 85Vac as the minimum bus voltage $V_{IN(min)}$ falls below the LED stack voltage ($V_{LED(max)}$) during part of the AC line cycle, driving the LED off.

Figure 6 shows the power factor across the line voltage range. Power factor greater than 0.9 can be achieved at 85Vac.

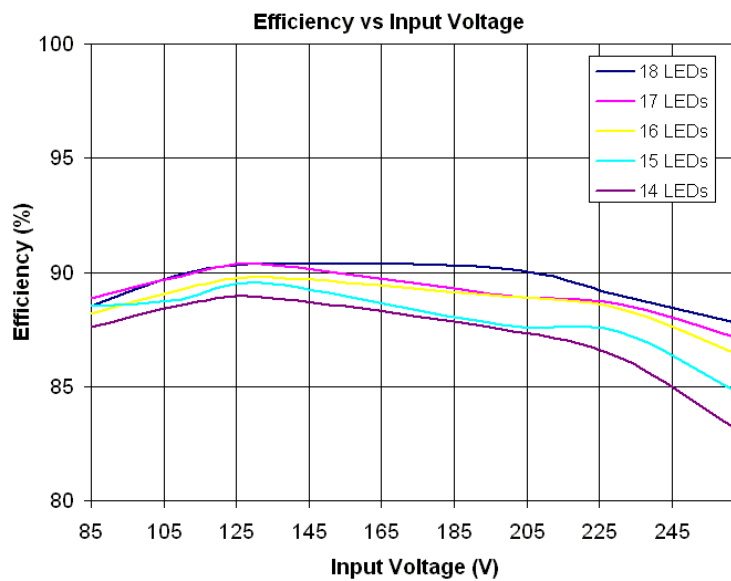

Figure 4 LED driver system efficiency

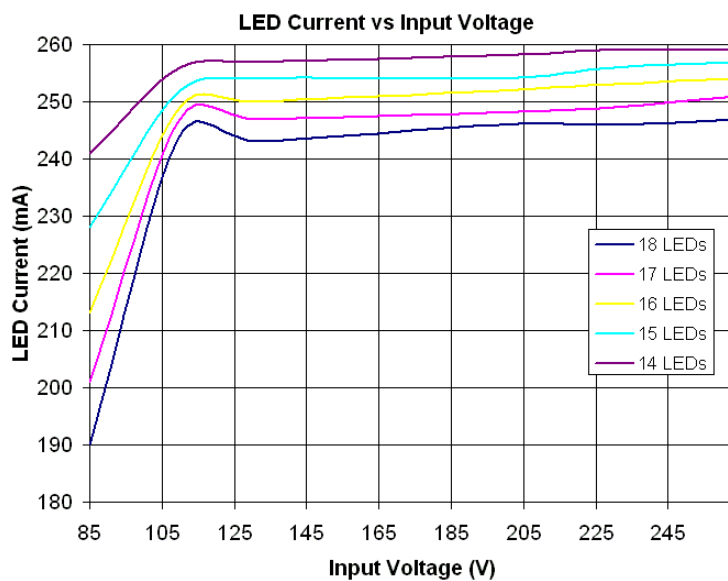

Figure 5 LED driver current regulation

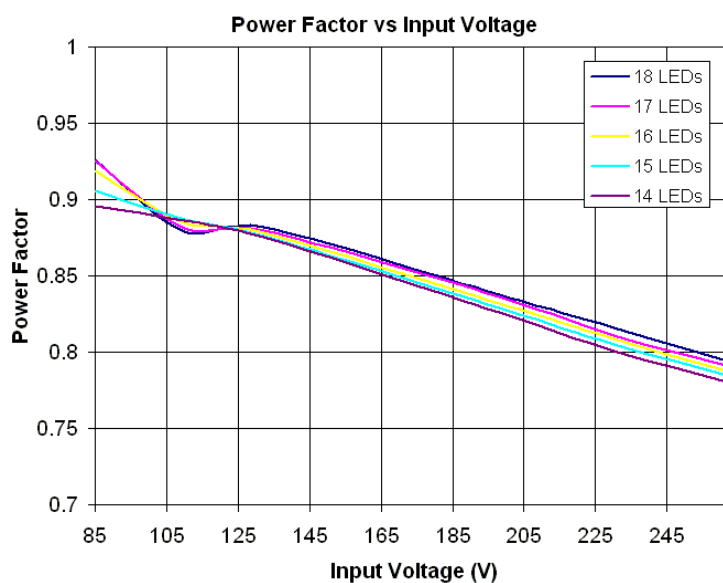

Figure 6 LED driver power factor

Conclusion

This application note provides a simple tool to design an offline LED driver using the AL9910 high voltage LED controller. It provides a high level of efficiency as well as LED current control over a wide range of input voltages. Moreover the document explains how to design a system with passive power factor correction to achieve PF greater than 0.7, allowing compliant with emergent international solid state lighting standards.

IMPORTANT NOTICE

DIODES INCORPORATED MAKES NO WARRANTY OF ANY KIND, EXPRESS OR IMPLIED, WITH REGARDS TO THIS DOCUMENT, INCLUDING, BUT NOT LIMITED TO, THE IMPLIED WARRANTIES OF MERCHANTABILITY AND FITNESS FOR A PARTICULAR PURPOSE (AND THEIR EQUIVALENTS UNDER THE LAWS OF ANY JURISDICTION).

Diodes Incorporated and its subsidiaries reserve the right to make modifications, enhancements, improvements, corrections or other changes without further notice to this document and any product described herein. Diodes Incorporated does not assume any liability arising out of the application or use of this document or any product described herein; neither does Diodes Incorporated convey any license under its patent or trademark rights, nor the rights of others. Any Customer or user of this document or products described herein in such applications shall assume all risks of such use and will agree to hold Diodes Incorporated and all the companies whose products are represented on Diodes Incorporated website, harmless against all damages.

Diodes Incorporated does not warrant or accept any liability whatsoever in respect of any products purchased through unauthorized sales channel.

Should Customers purchase or use Diodes Incorporated products for any unintended or unauthorized application, Customers shall indemnify and hold Diodes Incorporated and its representatives harmless against all claims, damages, expenses, and attorney fees arising out of, directly or indirectly, any claim of personal injury or death associated with such unintended or unauthorized application.

Products described herein may be covered by one or more United States, international or foreign patents pending. Product names and markings noted herein may also be covered by one or more United States, international or foreign trademarks.

LIFE SUPPORT

Diodes Incorporated products are specifically not authorized for use as critical components in life support devices or systems without the express written approval of the Chief Executive Officer of Diodes Incorporated. As used herein:

A. Life support devices or systems are devices or systems which:

1. are intended to implant into the body, or
2. support or sustain life and whose failure to perform when properly used in accordance with instructions for use provided in the labeling can be reasonably expected to result in significant injury to the user.

B. A critical component is any component in a life support device or system whose failure to perform can be reasonably expected to cause the failure of the life support device or to affect its safety or effectiveness.

Customers represent that they have all necessary expertise in the safety and regulatory ramifications of their life support devices or systems, and acknowledge and agree that they are solely responsible for all legal, regulatory and safety-related requirements concerning their products and any use of Diodes Incorporated products in such safety-critical, life support devices or systems, notwithstanding any devices- or systems-related information or support that may be provided by Diodes Incorporated. Further, Customers must fully indemnify Diodes Incorporated and its representatives against any damages arising out of the use of Diodes Incorporated products in such safety-critical, life support devices or systems.

Copyright © 2011, Diodes Incorporated

www.diodes.com