

< Silicon RF Power MOS FET (Discrete) >

RD01MUS2B

RoHS Compliance, Silicon MOSFET Power Transistor 527MHz,1W

DESCRIPTION

RD01MUS2B is a MOS FET type transistor specifically designed for VHF/UHF RF amplifiers applications.

This device has an internal monolithic zener diode from gate to source for ESD protection.

FEATURES

- High power gain and High Efficiency.
Pout 1.6W Typ, Gp 15dBTyp, 70%Typ
@Vdd=7.2V,f=527MHz
- Integrated gate protection diode

APPLICATION

For output stage of high power amplifiers in VHF/UHF Band mobile radio sets.

RoHS COMPLIANCE

RD01MUS2B-101,T113 is a RoHS compliant products.

This product includes the lead in high melting temperature type solders.

However, it is applicable to the following exceptions of RoHS Directions.

- 1.Lead in high melting temperature type solders (i.e.tin-lead solder alloys containing more than 85% lead.)

ABSOLUTE MAXIMUM RATINGS

(Tc=25°C UNLESS OTHERWISE NOTED)

SYMBOL	PARAMETER	CONDITIONS	RATINGS	UNIT
VDSS	Drain to source voltage	Vgs=0V	25	V
VGSS	Gate to source voltage	Vds=0V	-5/+10	V
Pch	Channel dissipation	Tc=25°C	3.6	W
Pin	Input Power	Zg=Zl=50Ω	100	mW
ID	Drain Current	-	600	mA
Tch	Channel Temperature	-	150	°C
Tstg	Storage temperature	-	-40 to +125	°C
Rth j-c	Thermal resistance	Junction to case	34.5	°C/W

Note: Above parameters are guaranteed independently.

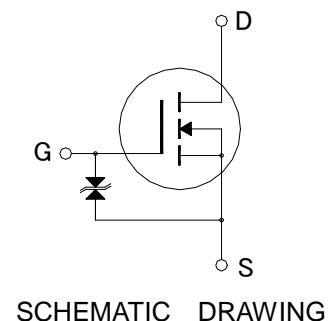
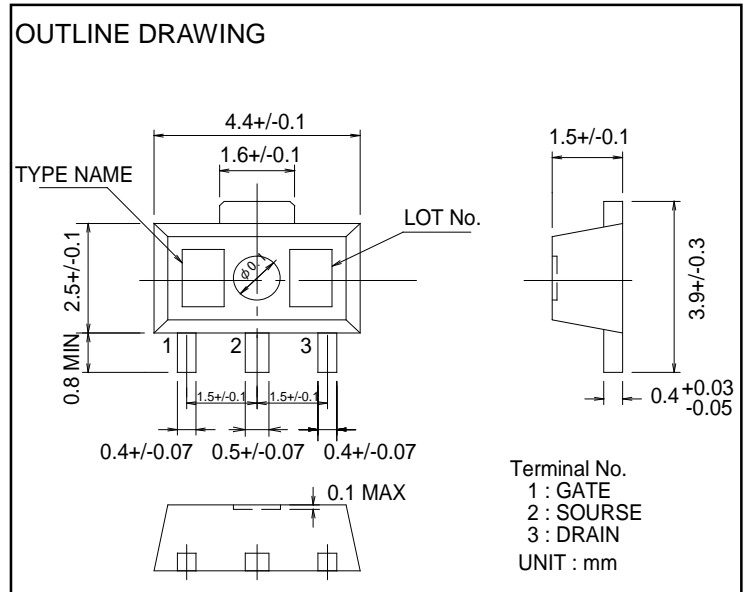

< Silicon RF Power MOS FET (Discrete) >

RD01MUS2B

RoHS Compliance, Silicon MOSFET Power Transistor 527MHz,1W

ELECTRICAL CHARACTERISTICS

(T_c=25°C, UNLESS OTHERWISE NOTED)

SYMBOL	PARAMETER	CONDITIONS	LIMITS			UNIT
			MIN	TYP	MAX	
I _{DSS}	Zero gate voltage drain current	V _{DS} =17V, V _{GS} =0V	-	-	50	uA
I _{GSS}	Gate to source leak current	V _{GS} =10V, V _{DS} =0V	-	-	1	uA
V _{th}	Gate threshold Voltage	V _{DS} =7.2V, I _{DS} =1mA	0.5	1.0	1.5	V
P _{out}	Output power	V _{DD} =7.2V, P _{in} =30mW	1.0	1.6	-	W
η _d	Drain efficiency	f=527MHz [*] , I _{dq} = 40mA	60	70	-	%

Note: Above parameters, ratings, limits and conditions are subject to change.

* In Mitsubishi 527MHz Test Circuit

RD01MUS2B

RoHS Compliance, Silicon MOSFET Power Transistor 527MHz,1W

TYPICAL CHARACTERISTICS

(These are only typical curves and devices are not necessarily guaranteed at these curves.)

CHANNEL DISSIPATION VS. AMBIENT TEMPERATURE

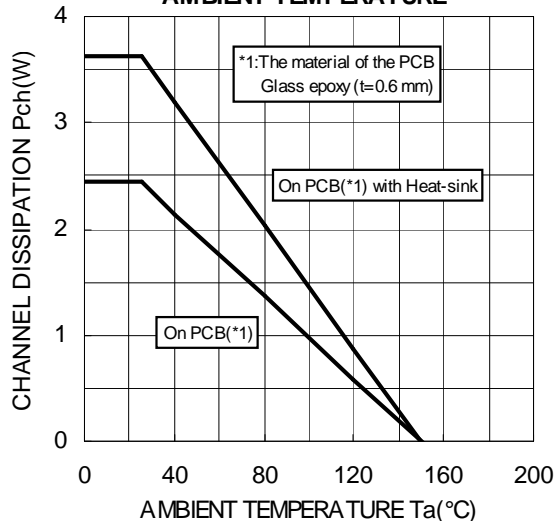

Vgs-Ids CHARACTERISTICS

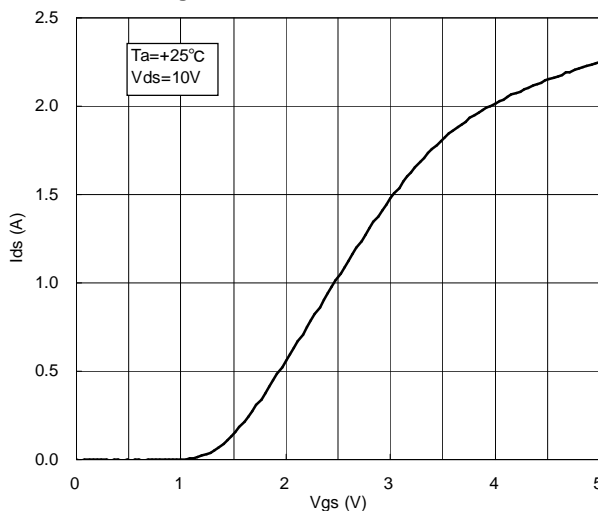

Vds-Ids CHARACTERISTICS

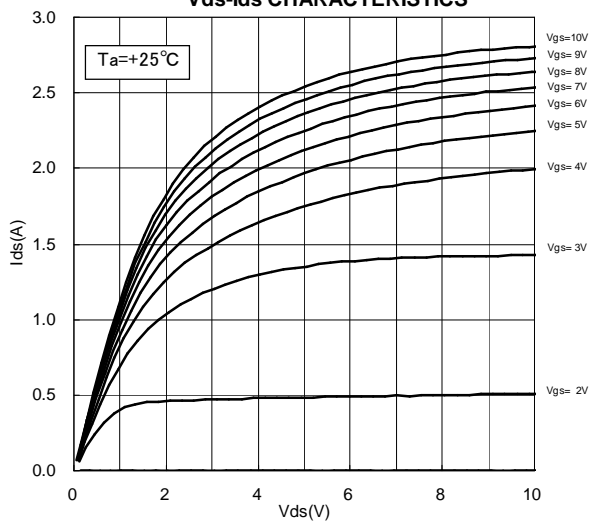

Vds VS. Ciss CHARACTERISTICS

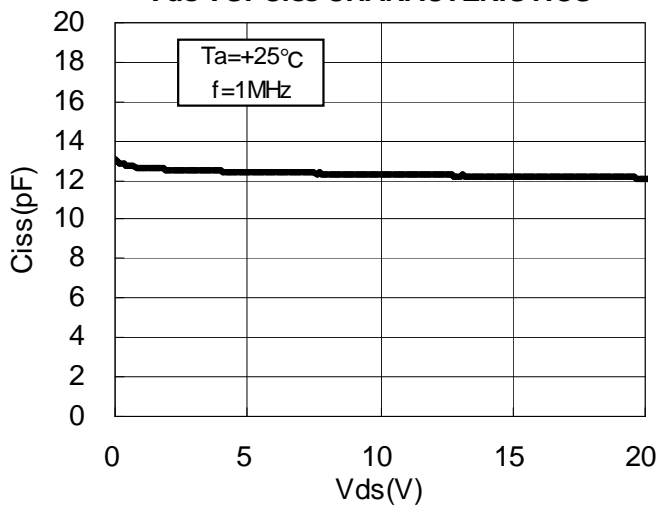

Vds VS. Crss CHARACTERISTICS

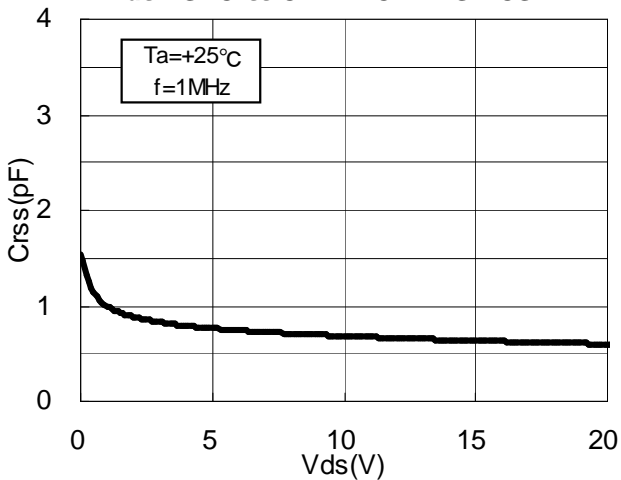

Vds VS. Coss CHARACTERISTICS

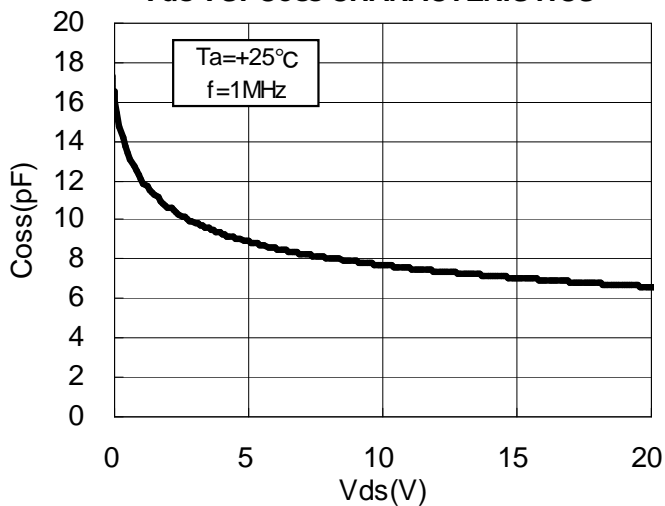

RD01MUS2B

RoHS Compliance, Silicon MOSFET Power Transistor 527MHz,1W

UHF-band,527MHz, TYPICAL CHARACTERISTICS

(These are only typical curves and devices are not necessarily guaranteed at these curves.)

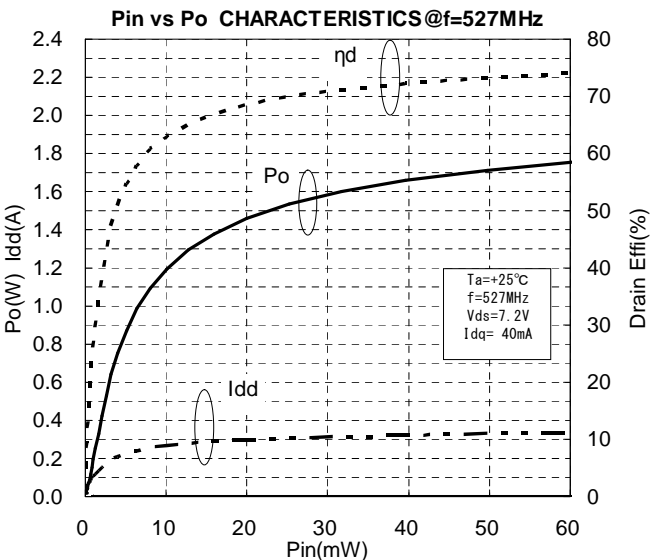
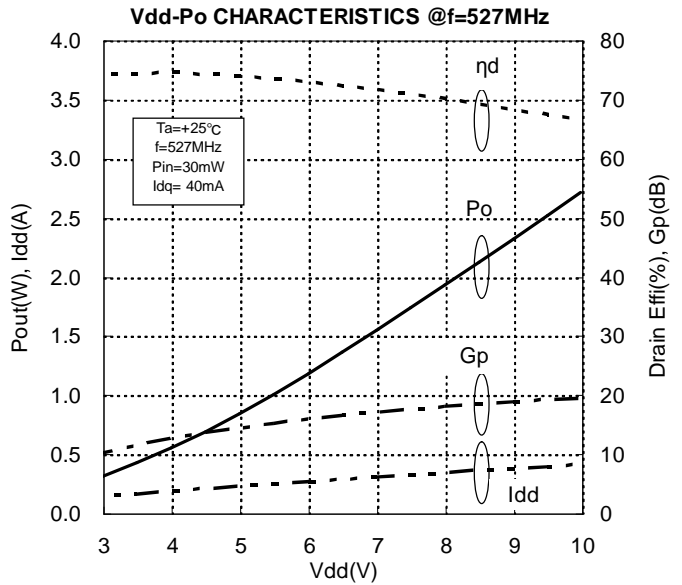
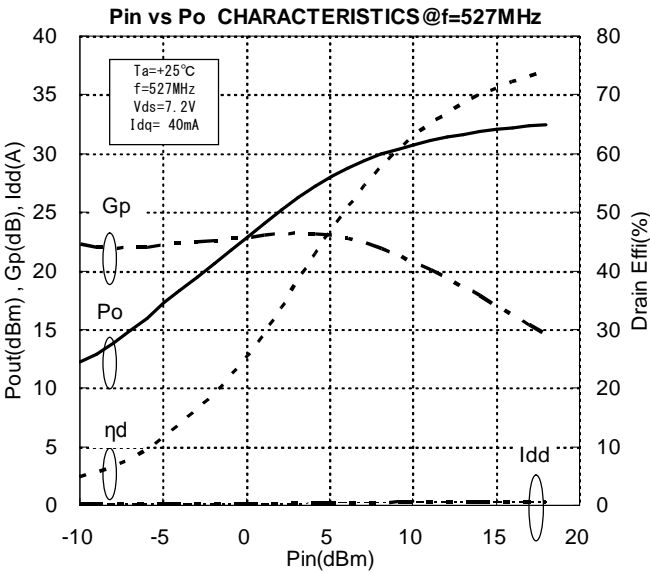
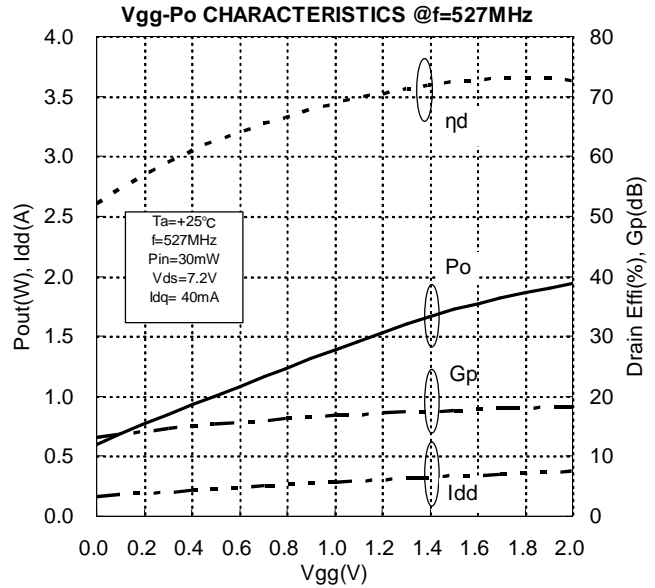
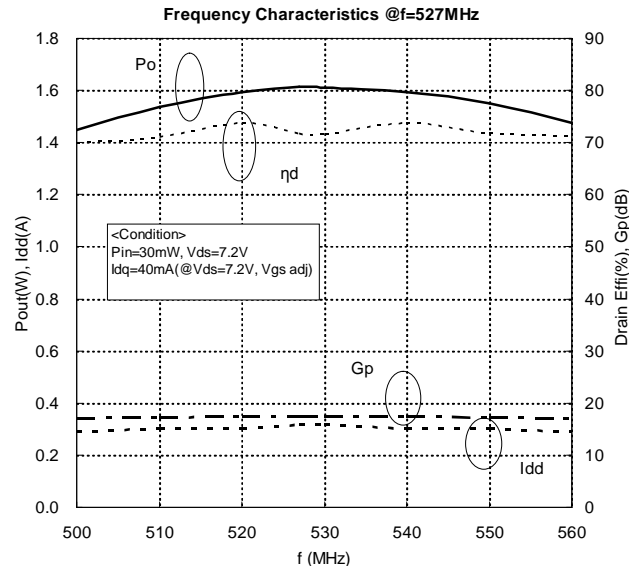

RD01MUS2B

RoHS Compliance, Silicon MOSFET Power Transistor 527MHz,1W

EQUIVALENT CIRCUITRY for Test Circuit (f=527MHz)

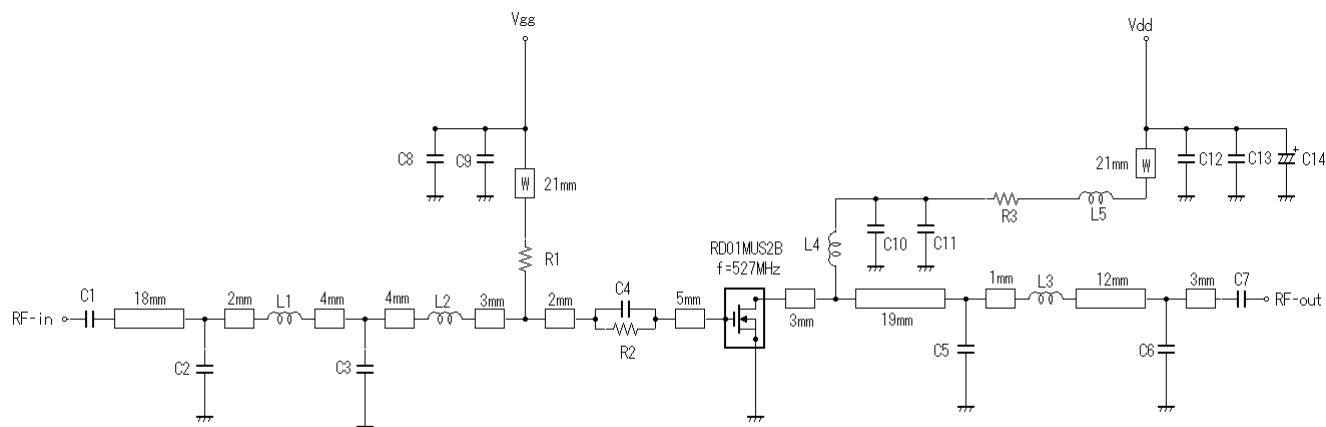

Note: Board material- Glass-Epoxy Substrate
 Micro strip line width=1.3mm/500HM, er:4.8, t=0.8mm
 W: Line width=1.0mm

C1	1000 pF	Chip Ceramic Capacitors
C2	10 pF	Chip Ceramic Capacitors
C3	33 pF	Chip Ceramic Capacitors
C4	22 pF	Chip Ceramic Capacitors
C5	12 pF	Chip Ceramic Capacitors
C6	3 pF	Chip Ceramic Capacitors
C7	1000 pF	Chip Ceramic Capacitors
C8	0.022 μF	Chip Ceramic Capacitors
C9	1000 pF	Chip Ceramic Capacitors
C10	82 pF	Chip Ceramic Capacitors
C11	82 pF	Chip Ceramic Capacitors
C12	0.022 μF	Chip Ceramic Capacitors
C13	1000 pF	Chip Ceramic Capacitors
C14	22 μF	Electrolytic Capacitor
R1	4.7K ohm	Chip Resistors
R2	100 ohm	Chip Resistors
R3	0 ohm	Chip Resistors
L1	8 nH	Enameled wire 2Turns, D:0.23mm, Inside: 1.1mm
L2	8 nH	Enameled wire 2Turns, D:0.23mm, Inside: 1.1mm
L3	12 nH	Enameled wire 3Turns, D:0.23mm, Inside: 1.1mm
L4	12 nH	Enameled wire 3Turns, D:0.23mm, Inside: 1.1mm
L5	29 nH	Enameled wire 6Turns, D:0.40mm, Inside: 1.6mm

* Inductor of Rolling Coil measurement condition : f=100MHz

RD01MUS2B

RoHS Compliance, Silicon MOSFET Power Transistor 527MHz,1W

Zout* (f=527MHz)

Zo=50ohm

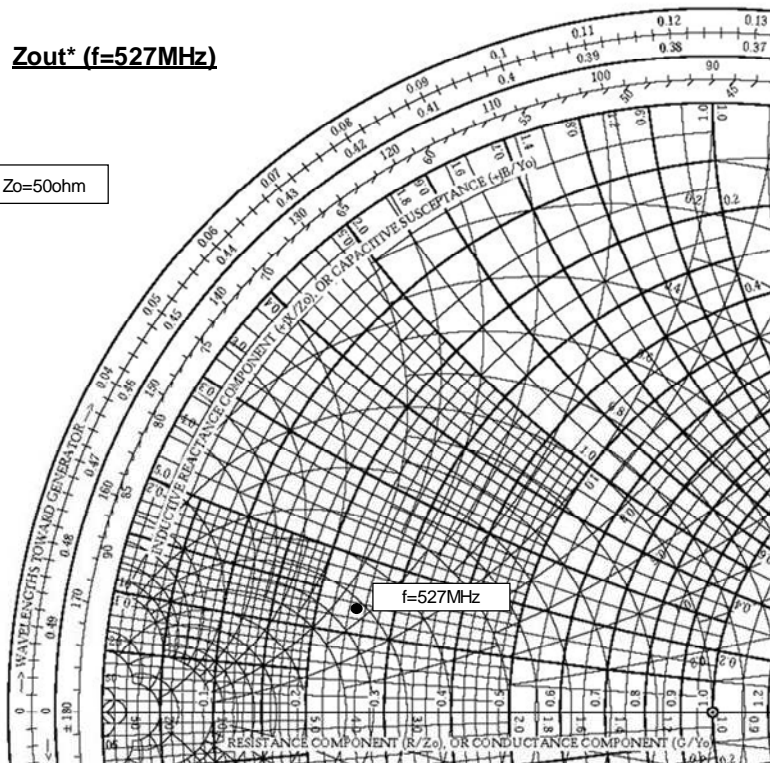

@ Pin=30mW, Vds=7.2V, Idq=40mA

f (MHz)	Zout* (ohm)
527	12.67 + j 6.67

Zout*: Complex conjugate of output impedance

Zin* (f=527MHz)

Zo=50ohm

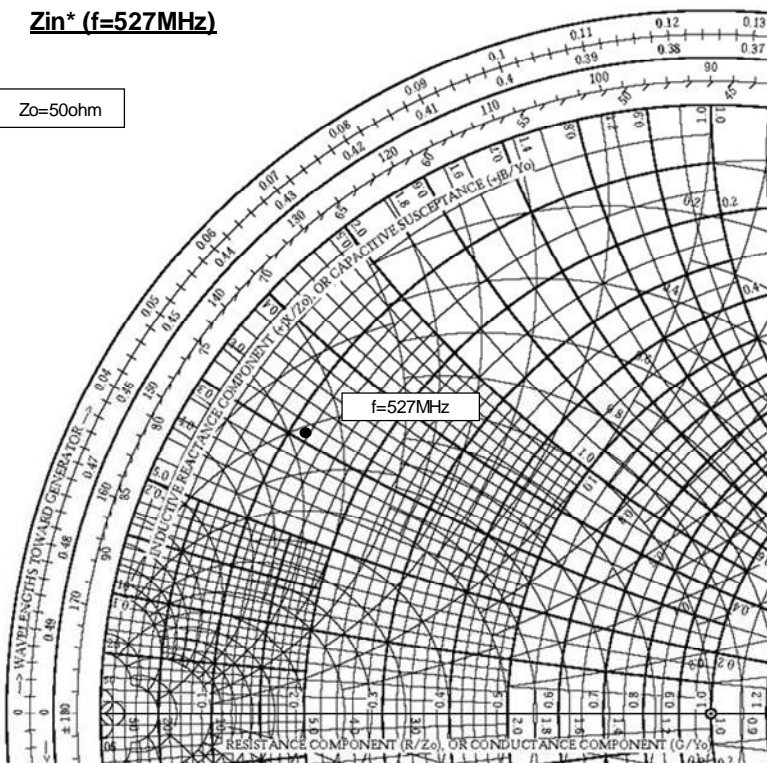

@ Pin=30mW, Vds=7.2V, Idq=40mA

f (MHz)	Zin* (ohm)
527	5.93 + j 15.54

Zin*: Complex conjugate of input impedance

RD01MUS2B

RoHS Compliance, Silicon MOSFET Power Transistor 527MHz,1W

VHF-band TYPICAL CHARACTERISTICS

(These are only typical curves and devices are not necessarily guaranteed at these curves.)

Frequency Characteristics @f=135-175MHz

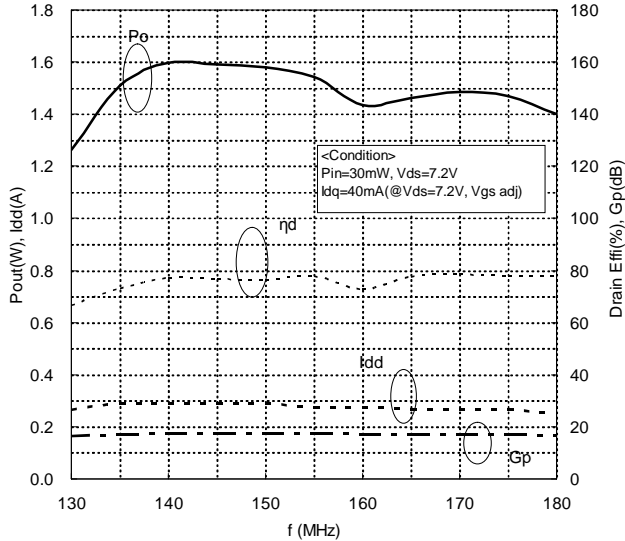

V_{gg}-P_o CHARACTERISTICS @f=135/155/175MHz

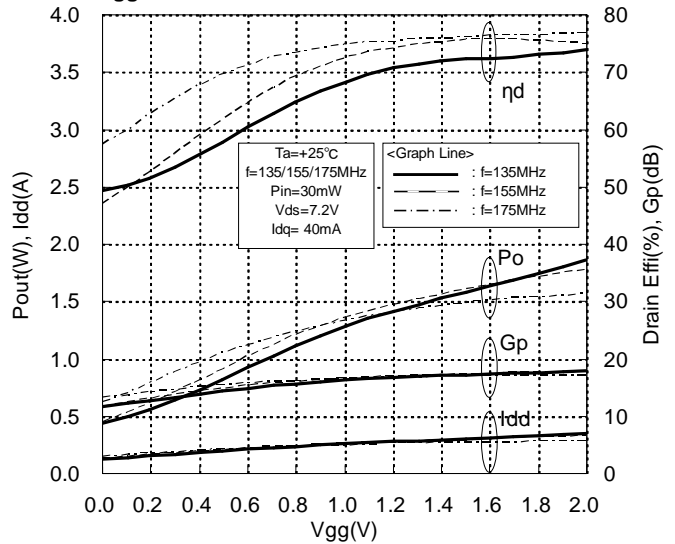

Pin vs Po CHARACTERISTICS @f=135/155/175MHz

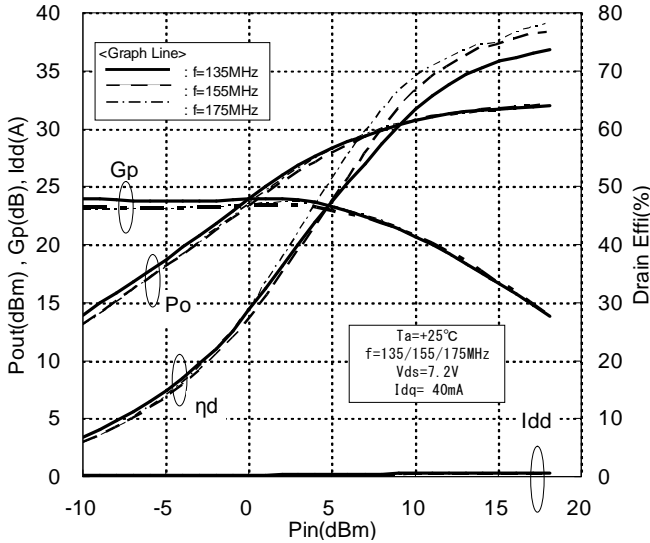

V_{dd}-P_o CHARACTERISTICS @f=135/155/175MHz

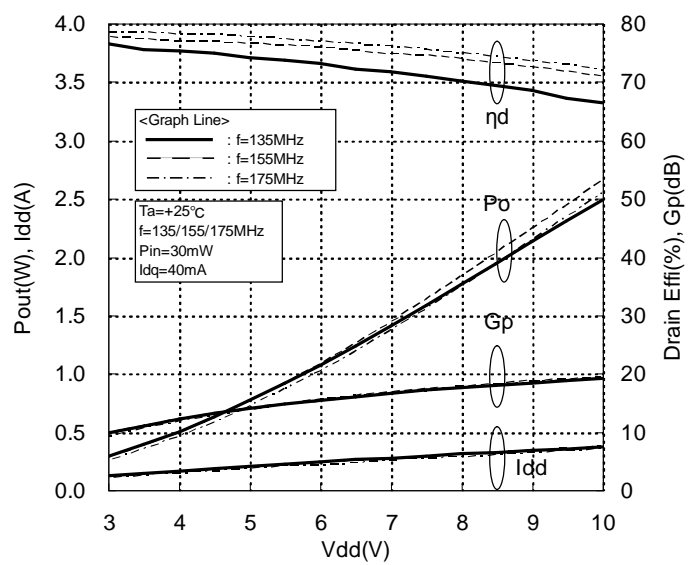

Pin vs Po CHARACTERISTICS @f=135/155/175MHz

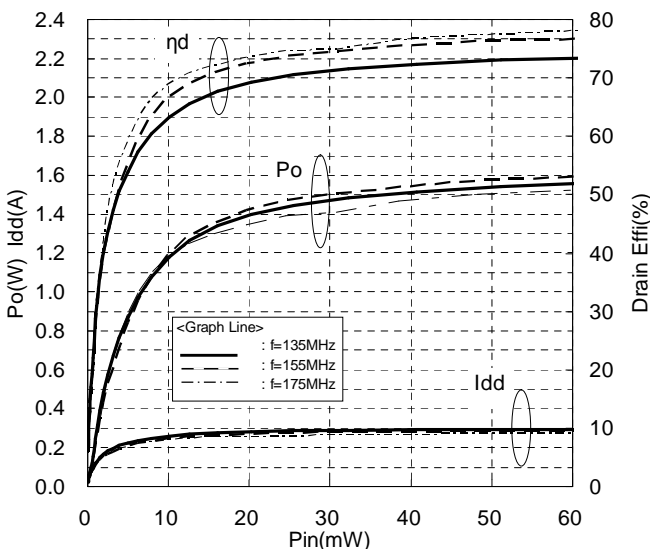

RD01MUS2B

RoHS Compliance, Silicon MOSFET Power Transistor 527MHz,1W

EQUIVALENT CIRCUITRY for VHF EVALUATION BOARD (f=135 – 175MHz)

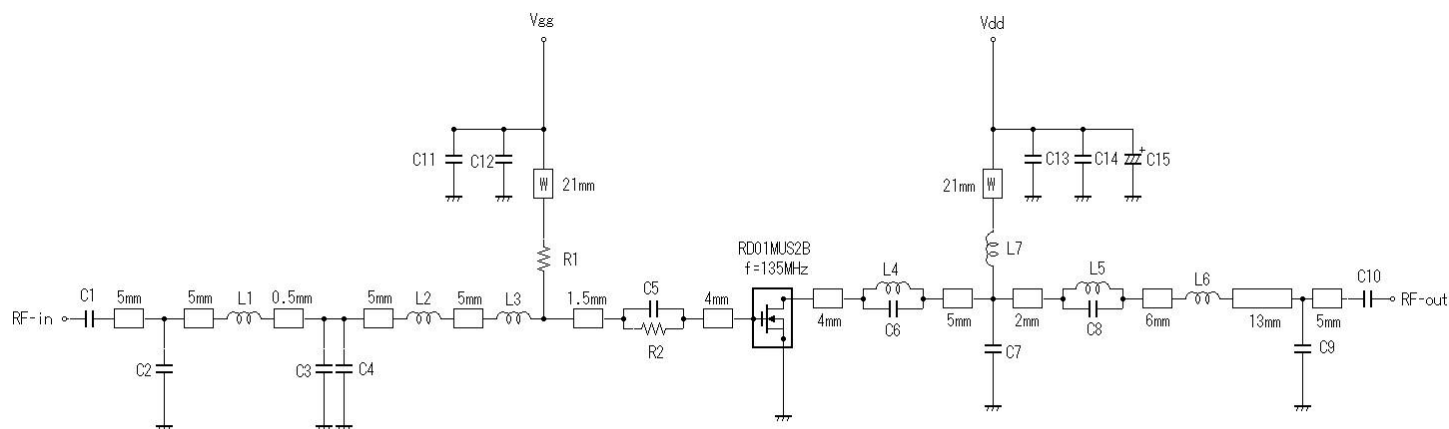

Note: Board material- Glass-Epoxy Substrate
 Micro strip line width=1.3mm/500HM, er:4.8, t:0.8mm
 W: Line width=1.0mm

C1	160 pF	Chip Ceramic Capacitors
C2	36 pF	Chip Ceramic Capacitors
C3	22 pF	Chip Ceramic Capacitors
C4	27 pF	Chip Ceramic Capacitors
C5	22 pF	Chip Ceramic Capacitors
C6	430 pF	Chip Ceramic Capacitors
C7	10 pF	Chip Ceramic Capacitors
C8	7 pF	Chip Ceramic Capacitors
C9	18 pF	Chip Ceramic Capacitors
C10	160 pF	Chip Ceramic Capacitors
C11	1000 pF	Chip Ceramic Capacitors
C12	0.022 μ F	Chip Ceramic Capacitors
C13	1000 pF	Chip Ceramic Capacitors
C14	0.022 μ F	Chip Ceramic Capacitors
C15	22 μ F	Electrolytic Capacitor
R1	4.7K ohm	Chip Resistors
R2	47 ohm	Chip Resistors
L1	40 nH	Enameled wire 9Turns, D:0.23mm, Inside: 1.1mm
L2	51 nH	Enameled wire 11Turns, D:0.23mm, Inside: 1.1mm
L3	40 nH	Enameled wire 9Turns, D:0.23mm, Inside: 1.1mm
L4	12 nH	Enameled wire 3Turns, D:0.23mm, Inside: 1.1mm
L5	17 nH	Enameled wire 4Turns, D:0.23mm, Inside: 1.1mm
L6	12 nH	Enameled wire 3Turns, D:0.23mm, Inside: 1.1mm
L7	37 nH	Enameled wire 7Turns, D:0.4mm, Inside: 1.6mm

* Inductor of Rolling Coil measurement condition : f=100MHz

For more information regarding this evaluation board, refer to APPLICATION NOTE "AN-VHF-055"

RD01MUS2B

RoHS Compliance, Silicon MOSFET Power Transistor 527MHz,1W

Input / Output Impedance VS. Frequency Characteristics

Zout* (f=135, 155, 175MHz)

Zo=50ohm

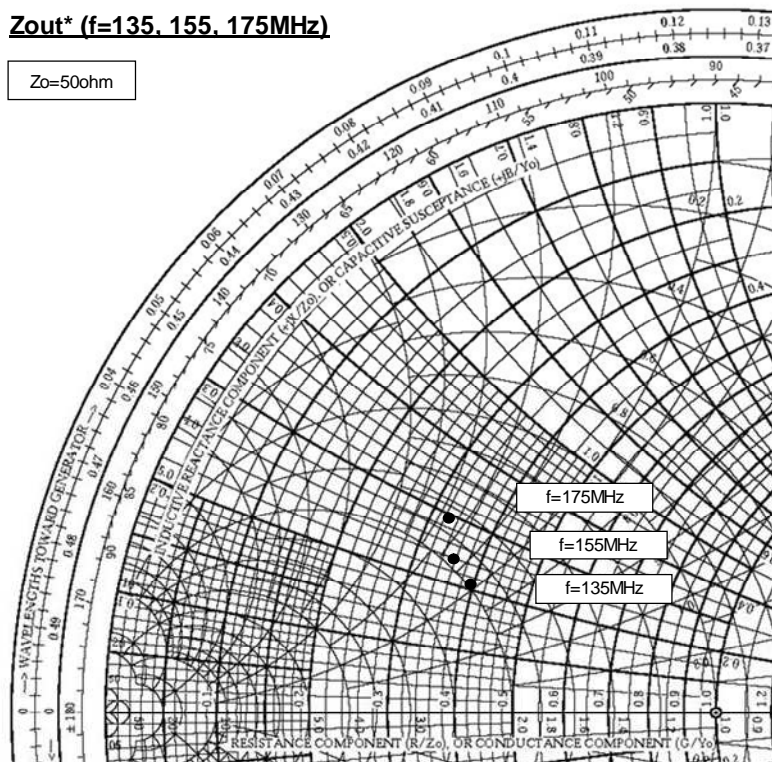

@Pin=30mW, Vds=7.2V, Idq=40mA

f (MHz)	Zout* (ohm)
135	19.81 + j 10.17
155	18.09 + j 11.73
175	16.62 + j 14.82

Zout*: Complex conjugate of output impedance

Zin* (f=135, 155, 175MHz)

Zo=50ohm

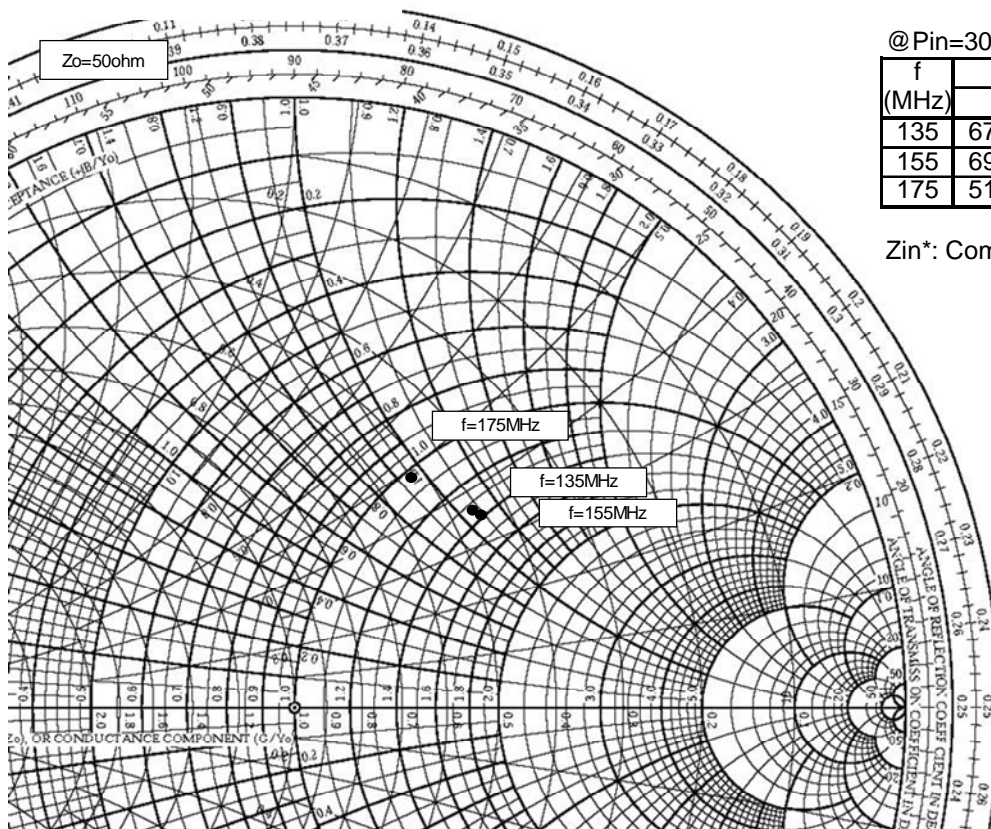

@Pin=30mW, Vds=7.2V, Idq=40mA

f (MHz)	Zin* (ohm)
135	67.91 + j 54.09
155	69.90 + j 54.62
175	51.90 + j 47.13

Zin*: Complex conjugate of input impedance

RD01MUS2B

RoHS Compliance, Silicon MOSFET Power Transistor 527MHz,1W

900MHz-band TYPICAL CHARACTERISTICS

(These are only typical curves and devices are not necessarily guaranteed at these curves.)

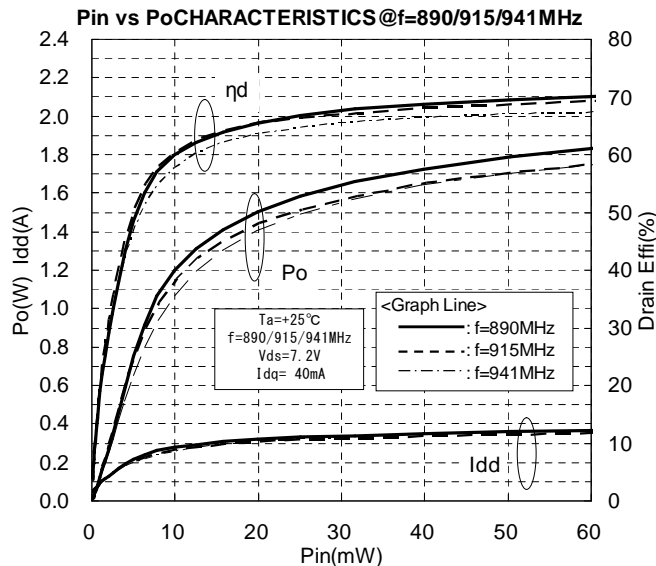
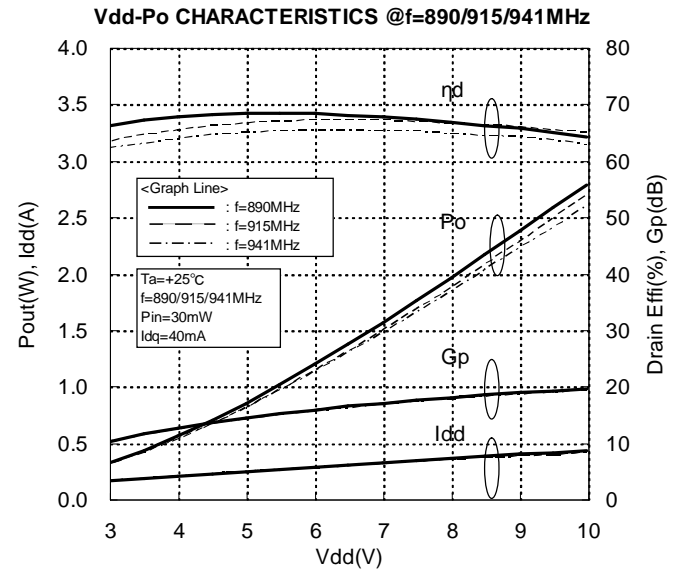
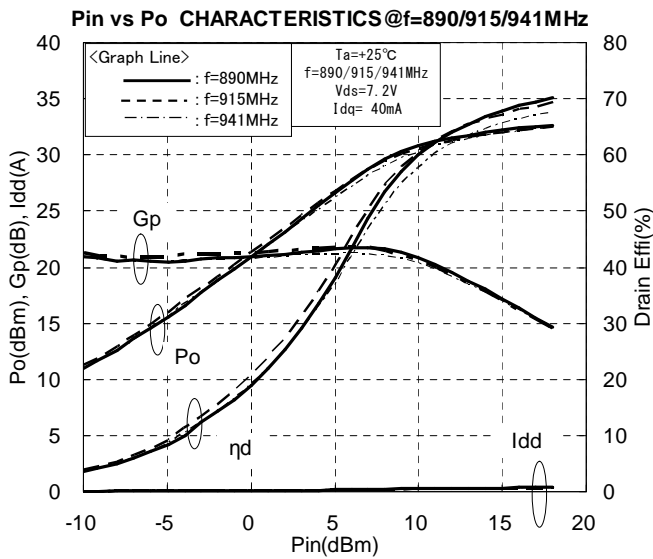
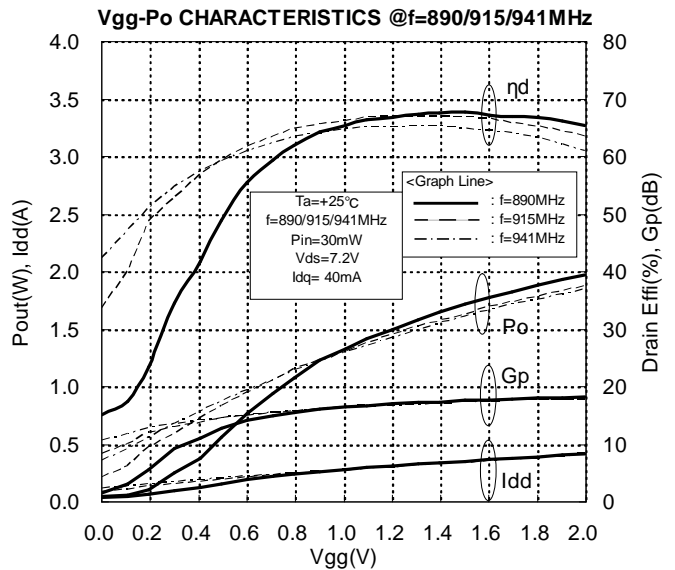
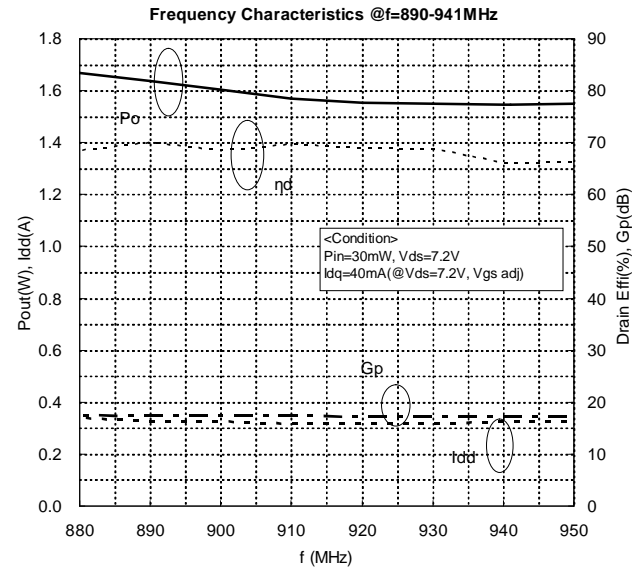

RD01MUS2B

RoHS Compliance, Silicon MOSFET Power Transistor 527MHz,1W

EQUIVALENT CIRCUITRY for 900MHz EVALUATION BOARD (f=890 – 941MHz)

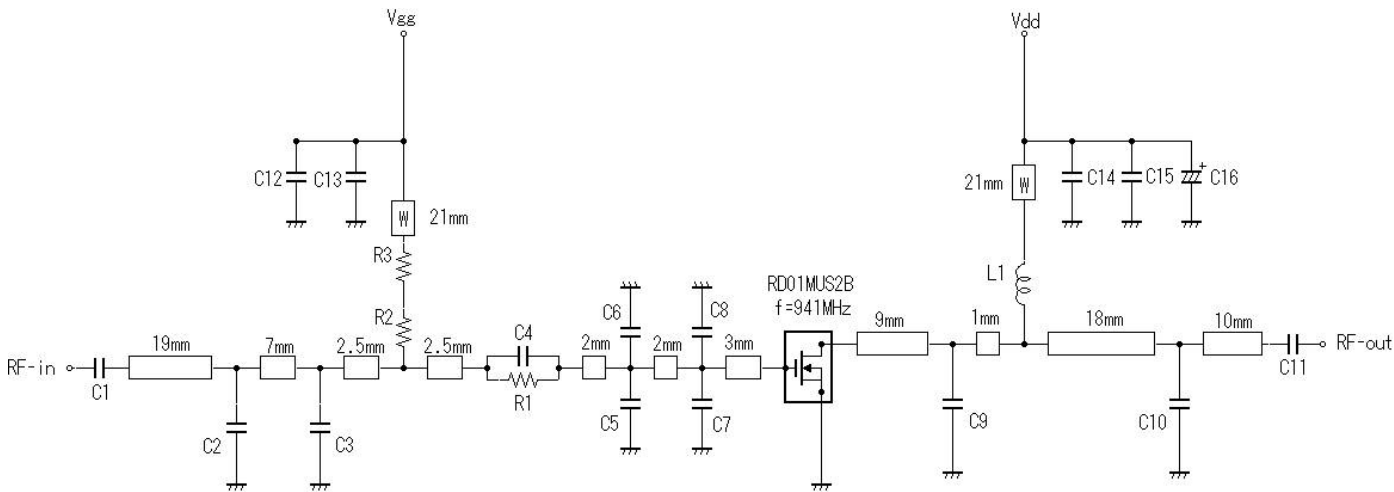

Note:Board material- Glass-Epoxy Substrate
 Micro strip line width=1.3mm/500HM,er:4.8,t=0.8mm
 W:Line width=1.0mm

C1	150 pF	Chip Ceramic Capacitors
C2	4 pF	Chip Ceramic Capacitors
C3	4 pF	Chip Ceramic Capacitors
C4	30 pF	Chip Ceramic Capacitors
C5	10 pF	Chip Ceramic Capacitors
C6	10 pF	Chip Ceramic Capacitors
C7	10 pF	Chip Ceramic Capacitors
C8	10 pF	Chip Ceramic Capacitors
C9	8 pF	Chip Ceramic Capacitors
C10	2 pF	Chip Ceramic Capacitors
C11	150 pF	Chip Ceramic Capacitors
C12	100 pF	Chip Ceramic Capacitors
C13	1000 pF	Chip Ceramic Capacitors
C14	100 pF	Chip Ceramic Capacitors
C15	1000 pF	Chip Ceramic Capacitors
C16	22 μF	Electrolytic Capacitor
R1	18 ohm	Chip Resistors
R2	4.7K ohm	Chip Resistors
R3	0 ohm	Chip Resistors
L1	37 nH	Enameled wire 7Turns, D:0.40mm, Inside: 1.6mm

*Inductor of Rolling Coil measurement condition : f=100MHz

For more information regarding this evaluation board, refer to APPLICATION NOTE “AN-900-046”

RD01MUS2B

RoHS Compliance, Silicon MOSFET Power Transistor 527MHz,1W

Zout* (f=890, 915, 941MHz)

Zo=50ohm

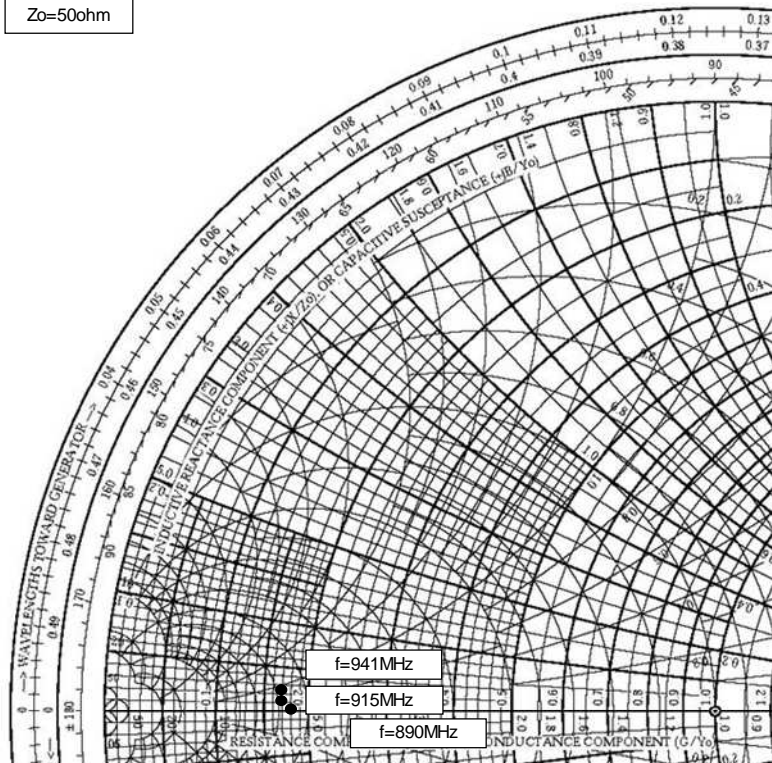

@ Pin=30mW, Vds=7.2V, Idq=40mA

f (MHz)	Zout* (ohm)
890	8.80 - j 0.18
915	8.60 + j 0.37
941	8.39 + j 1.01

Zout*: Complex conjugate of output impedance

Zin* (f=890, 915, 941MHz)

Zo=50ohm

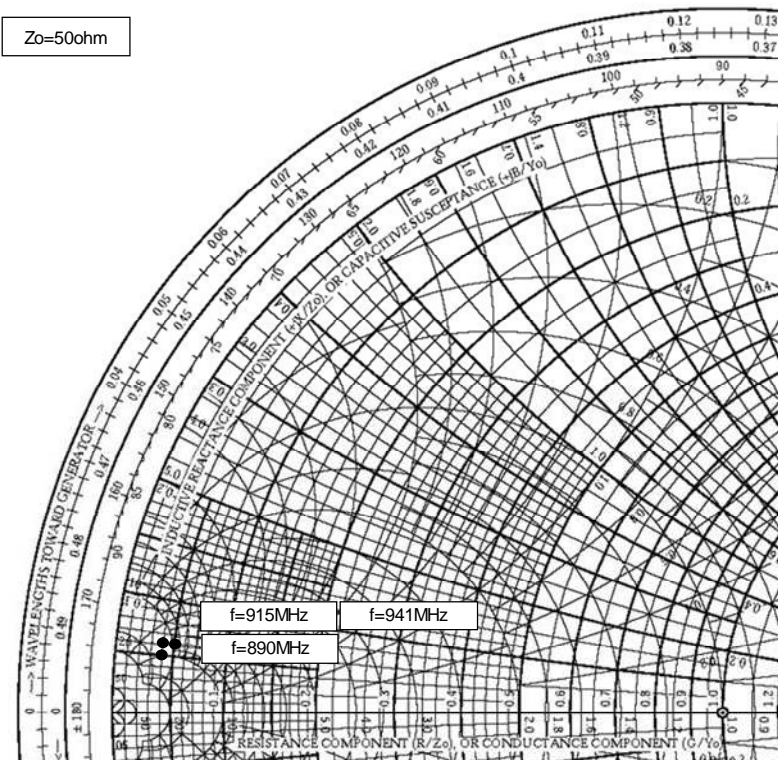

@ Pin=30mW, Vds=7.2V, Idq=40mA

f (MHz)	Zin* (ohm)
890	2.09 + j 2.48
915	2.19 + j 2.78
941	2.37 + j 2.82

Zin*: Complex conjugate of input impedance

RD01MUS2B

RoHS Compliance, Silicon MOSFET Power Transistor 527MHz,1W

RD01MUS2B S-PARAMETER DATA (@Vdd=7.2V, Id=40mA)

Freq. [MHz]	S11		S21		S12		S22	
	(mag)	(ang)	(mag)	(ang)	(mag)	(ang)	(mag)	(ang)
100	0.896	-71.0	22.155	135.1	0.029	46.0	0.775	-56.6
135	0.862	-84.5	19.556	126.6	0.033	37.5	0.730	-68.2
155	0.847	-92.3	17.994	121.7	0.035	32.3	0.705	-74.9
175	0.835	-99.1	16.612	117.4	0.036	28.1	0.685	-80.9
200	0.823	-106.4	15.109	112.9	0.038	23.9	0.667	-87.3
250	0.809	-118.1	12.570	105.0	0.039	17.0	0.647	-97.8
300	0.803	-127.0	10.682	98.8	0.039	10.9	0.640	-105.8
350	0.800	-134.0	9.167	93.6	0.039	6.3	0.641	-112.5
400	0.801	-139.4	7.939	89.5	0.038	2.7	0.648	-118.1
450	0.806	-144.1	6.970	85.5	0.037	-0.2	0.660	-122.9
500	0.810	-148.0	6.160	82.2	0.036	-3.1	0.673	-127.2
520	0.813	-149.4	5.834	80.9	0.036	-4.4	0.679	-128.6
530	0.814	-150.1	5.698	80.5	0.035	-5.0	0.682	-129.4
550	0.816	-151.4	5.455	79.7	0.034	-5.8	0.687	-131.0
600	0.825	-154.5	4.898	77.1	0.033	-7.0	0.702	-134.4
650	0.831	-157.2	4.406	74.1	0.032	-8.9	0.718	-137.6
700	0.838	-159.6	3.969	72.6	0.030	-10.3	0.733	-140.6
750	0.845	-161.9	3.606	70.9	0.029	-11.5	0.746	-143.5
800	0.852	-164.0	3.249	68.9	0.027	-12.6	0.760	-146.2
850	0.859	-166.1	2.960	67.1	0.026	-12.8	0.774	-148.6
900	0.865	-167.9	2.703	67.2	0.025	-13.7	0.784	-151.1
950	0.870	-169.6	2.487	65.5	0.023	-14.2	0.795	-153.4
1000	0.876	-171.3	2.290	65.1	0.022	-14.7	0.805	-155.5
1050	0.882	-172.9	2.108	64.2	0.021	-13.9	0.816	-157.6
1100	0.887	-174.4	1.941	64.6	0.020	-15.9	0.825	-159.5
1150	0.891	-175.9	1.809	62.7	0.017	-16.5	0.832	-161.4
1200	0.894	-177.3	1.695	63.2	0.017	-13.3	0.841	-163.1
1250	0.898	-178.5	1.580	63.9	0.015	-13.3	0.849	-164.9
1300	0.902	-179.8	1.487	63.3	0.014	-12.0	0.856	-166.5
1350	0.907	-179.0	1.387	62.5	0.013	-10.5	0.863	-168.2
1400	0.912	-177.7	1.296	63.0	0.012	-8.3	0.868	-169.7
1450	0.914	-176.6	1.250	62.2	0.011	-8.2	0.875	-171.1
1500	0.917	-175.5	1.147	61.9	0.010	-5.0	0.880	-172.6

RD01MUS2B

RoHS Compliance, Silicon MOSFET Power Transistor 527MHz,1W

ATTENTION:

- 1.High Temperature ; This product might have a heat generation while operation,Please take notice that have a possibility to receive a burn to touch the operating product directly or touch the product until cold after switch off. At the near the product,do not place the combustible material that have possibilities to arise the fire.
- 2.Generation of High Frequency Power ; This product generate a high frequency power. Please take notice that do not leakage the unnecessary electric wave and use this products without cause damage for human and property per normal operation.
- 3.Before use; Before use the product,Please design the equipment in consideration of the risk for human and electric wave obstacle for equipment.

PRECAUTIONS FOR THE USE OF MITSUBISHI SILICON RF POWER DEVICES:

1. The specifications of mention are not guarantee values in this data sheet. Please confirm additional details regarding operation of these products from the formal specification sheet. For copies of the formal specification sheets, please contact one of our sales offices.
- 2.RA series products (RF power amplifier modules) and RD series products (RF power transistors) are designed for consumer mobile communication terminals and were not specifically designed for use in other applications. In particular, while these products are highly reliable for their designed purpose, they are not manufactured under a quality assurance testing protocol that is sufficient to guarantee the level of reliability typically deemed necessary for critical communications elements and In the application, which is base station applications and fixed station applications that operate with long term continuous transmission and a higher on-off frequency during transmitting, please consider the derating, the redundancy system, appropriate setting of the maintain period and others as needed. For the reliability report which is described about predicted operating life time of Mitsubishi Silicon RF Products , please contact Mitsubishi Electric Corporation or an authorized Mitsubishi Semiconductor product distributor.
3. RD series products use MOSFET semiconductor technology. They are sensitive to ESD voltage therefore appropriate ESD precautions are required.
4. In the case of use in below than recommended frequency, there is possibility to occur that the device is deteriorated or destroyed due to the RF-swing exceed the breakdown voltage.
5. In order to maximize reliability of the equipment, it is better to keep the devices temperature low. It is recommended to utilize a sufficient sized heat-sink in conjunction with other cooling methods as needed (fan, etc.) to keep the channel temperature for RD series products lower than 120deg/C(in case of Tchmax=150deg/C) ,140deg/C(in case of Tchmax=175deg/C) under standard conditions.
6. Do not use the device at the exceeded the maximum rating condition. In case of plastic molded devices, the exceeded maximum rating condition may cause blowout, smoldering or catch fire of the molding resin due to extreme short current flow between the drain and the source of the device. These results causes in fire or injury.
7. For specific precautions regarding assembly of these products into the equipment, please refer to the supplementary items in the specification sheet.
8. Warranty for the product is void if the products protective cap (lid) is removed or if the product is modified in any way from it's original form.
9. For additional "Safety first" in your circuit design and notes regarding the materials, please refer the last page of this data sheet.
10. Please refer to the additional precautions in the formal specification sheet.

RD01MUS2B

RoHS Compliance, Silicon MOSFET Power Transistor 527MHz,1W

Keep safety first in your circuit designs!

Mitsubishi Electric Corporation puts the maximum effort into making semiconductor products better and more reliable, but there is always the possibility that trouble may occur with them. Trouble with semiconductors may lead to personal injury, fire or property damage. Remember to give due consideration to safety when making your circuit designs, with appropriate measures such as (i) placement of substitutive, auxiliary circuits, (ii) use of non-flammable material or (iii) prevention against any malfunction or mishap.

Notes regarding these materials

- These materials are intended as a reference to assist our customers in the selection of the Mitsubishi semiconductor product best suited to the customer's application; they do not convey any license under any intellectual property rights, or any other rights, belonging to Mitsubishi Electric Corporation or a third party.
- Mitsubishi Electric Corporation assumes no responsibility for any damage, or infringement of any third-party's rights, originating in the use of any product data, diagrams, charts, programs, algorithms, or circuit application examples contained in these materials.
- All information contained in these materials, including product data, diagrams, charts, programs and algorithms represents information on products at the time of publication of these materials, and are subject to change by Mitsubishi Electric Corporation without notice due to product improvements or other reasons. It is therefore recommended that customers contact Mitsubishi Electric Corporation or an authorized Mitsubishi Semiconductor product distributor for the latest product information before purchasing a product listed herein.
The information described here may contain technical inaccuracies or typographical errors. Mitsubishi Electric Corporation assumes no responsibility for any damage, liability, or other loss rising from these inaccuracies or errors.
Please also pay attention to information published by Mitsubishi Electric Corporation by various means, including the Mitsubishi Semiconductor home page (<http://www.MitsubishiElectric.com/>).
- When using any or all of the information contained in these materials, including product data, diagrams, charts, programs, and algorithms, please be sure to evaluate all information as a total system before making a final decision on the applicability of the information and products. Mitsubishi Electric Corporation assumes no responsibility for any damage, liability or other loss resulting from the information contained herein.
- Mitsubishi Electric Corporation semiconductors are not designed or manufactured for use in a device or system that is used under circumstances in which human life is potentially at stake. Please contact Mitsubishi Electric Corporation or an authorized Mitsubishi Semiconductor product distributor when considering the use of a product contained herein for any specific purposes, such as apparatus or systems for transportation, vehicular, medical, aerospace, nuclear, or undersea repeater use.
- The prior written approval of Mitsubishi Electric Corporation is necessary to reprint or reproduce in whole or in part these materials.
- If these products or technologies are subject to the Japanese export control restrictions, they must be exported under a license from the Japanese government and cannot be imported into a country other than the approved destination.
Any diversion or re-export contrary to the export control laws and regulations of Japan and/or the country of destination is prohibited.
- Please contact Mitsubishi Electric Corporation or an authorized Mitsubishi Semiconductor product distributor for further details on these materials or the products contained therein.